

C. MOREHOUSE.
Hemmer for Sewing Machines.

No. 101,147.

Patented March 22, 1870

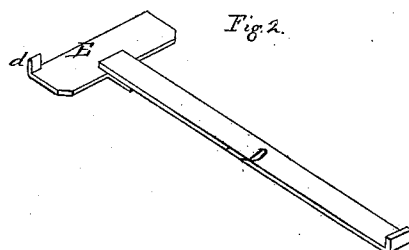
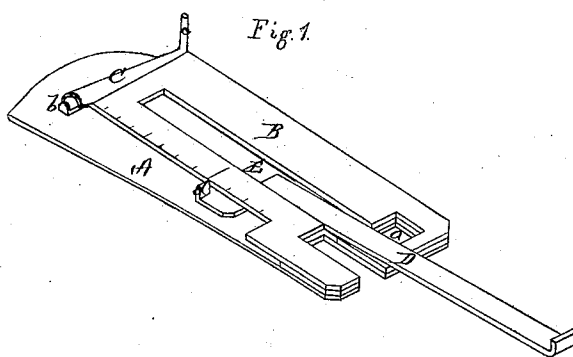

WITNESSES

Henry H. Miller
John A. Ellis

INVENTOR.

Clark Morehouse
Jes
J. H. Alexander
Atty

United States Patent Office.

CLARK MOREHOUSE, OF WAYLAND, ASSIGNOR TO SETH A. TOZER AND OSCAR N. CRANE, OF CANANDAIGUA, NEW YORK.

Letters Patent No. 101,147, dated March 22, 1870.

IMPROVEMENT IN HEMMER FOR SEWING-MACHINE.

The Schedule referred to in these Letters Patent and making part of the same

To all whom it may concern :

Be it known that I, CLARK MOREHOUSE, of Wayland, in the county of Steuben and State of New York, have invented certain new and useful Improvements in Hem-Gauges for Sewing-Machines; and I do hereby declare that the following is a full, clear, and exact description thereof, reference being had to the accompanying drawings and to the letters of reference marked thereon, which form a part of this specification.

The nature of my invention consists in the construction and arrangement of an adjustable hemming-guide for sewing-machines, by the use of which a hem of any desired width may be made.

In order to enable others skilled in the art to which my invention appertains to make and use the same, I will now proceed to describe its construction and operation, referring to the annexed drawings, in which—

Figure 1 is a perspective view of the entire attachment, and

Figure 2 is a perspective view of the sliding bar.

A represents the bed-piece, at one end of which the hemmer-plate B is attached.

At this end is a hole, *a*, through which a screw is passed to secure the device to the sewing-machine.

At the loose end of the hemmer-plate B is the trumpet or edge-turner C, which, at its larger end, is provided with a turned-up projection, *b*, and at its smaller end with a vertical rod, *c*, as seen in fig. 1.

The hemmer-plate B is slotted longitudinally, and in this slot is placed the sliding bar D, which is turned up at its rear end, and at its front end provided with the cross-plate E, which forms the guide to make the hem of any width desired.

At one end of the guide E is a raised projection, *d*, which extends upward close to the edge of the hemmer-plate B, said edge of the hemmer-plate being graduated, so that the guide can readily be set for any width of hem desired.

Having thus fully described my invention,

What I claim as new, and desire to secure by Letters Patent, is—

The attached stationary plates A B, the plate B being slotted and graduated, as shown, and provided with the hemming-scroll C and projecting pin *c*, and the sliding gauge-plate E B having the pointer *d*, all being constructed and arranged, as shown, to form hems of different widths.

In testimony that I claim the foregoing as my own, I affix my signature in presence of two witnesses.

CLARK MOREHOUSE.

Witnesses:

A. B. GARDNER,
H. S. PERRY.