



US00D357487S

United States Patent [19]

[11] Patent Number: **Des. 357,487**

Samelius et al.

[45] Date of Patent: **** Apr. 18, 1995**

[54] **CLAMP BUSHING HAVING AN INTEGRATED CONICAL MOUNTING MEANS**

3,871,138 3/1975 Welsch 51/170 PT
4,536,613 8/1985 Gallas 174/65 R

[76] Inventors: **Anders Samelius; Björn Ohlson; Stefan Lindström**, all of ETP Transmission, Box 1120, S-581 11 Linköping, Sweden

Primary Examiner—Alan P. Douglas
Assistant Examiner—Antoine D. Davis
Attorney, Agent, or Firm—Larson and Taylor

[**] Term: **14 Years**

[57] **CLAIM**

[21] Appl. No.: **12,054**

The ornamental design for a clamp bushing having an integrated conical mounting means, as shown and described.

[22] Filed: **Aug. 23, 1993**

DESCRIPTION

[30] **Foreign Application Priority Data**

Mar. 22, 1993 [SE] Sweden 930708

[52] U.S. Cl. **D15/143**

[58] Field of Search D15/138, 141, 143;
279/1 A, 22, 1 B, 75, 91, 1 F, 50; 51/170 PT;
174/65 R

FIG. 1 is a side view of our clamp bushing having an integrated conical mounting means all other side views being identical;

FIG. 2 is an end view of the clamp bushing having an integrated conical mounting means of FIG. 1 as seen from the left end thereof;

FIG. 3 is an end view of the clamp bushing having an integrated conical mounting means of FIG. 1 as seen from the right end thereof; and,

FIG. 4 is a perspective view of the right side of the clamp bushing having an integrated conical mounting means of FIG. 1.

[56] **References Cited**

U.S. PATENT DOCUMENTS

D. 330,900 11/1992 Wakegijig D15/138

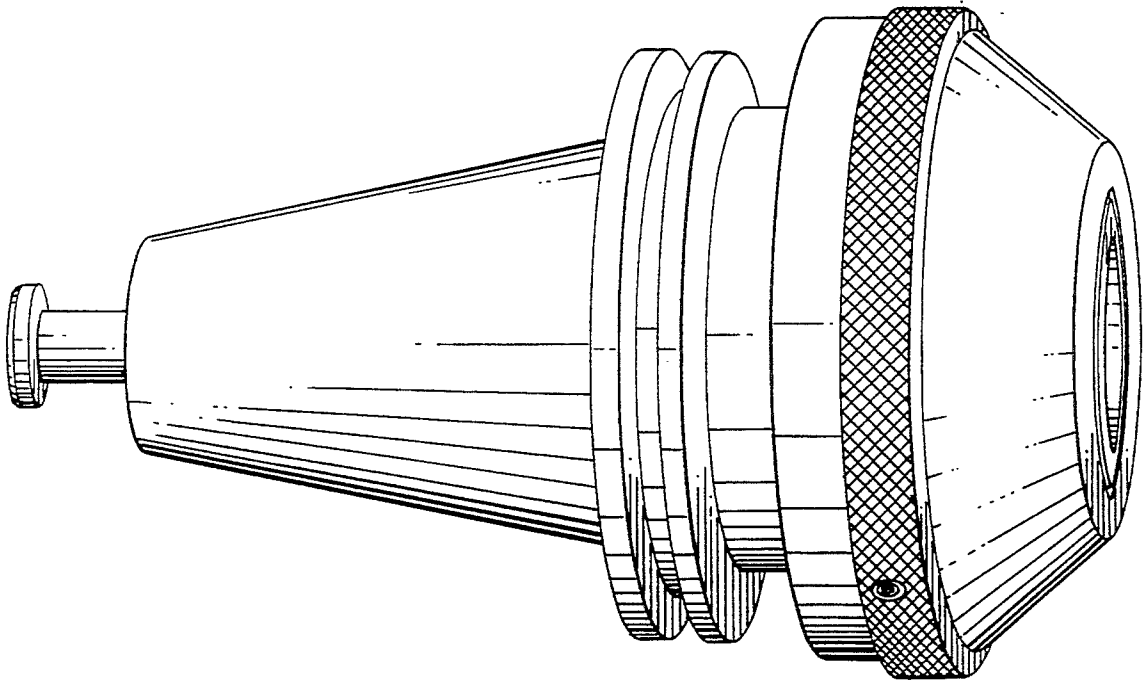

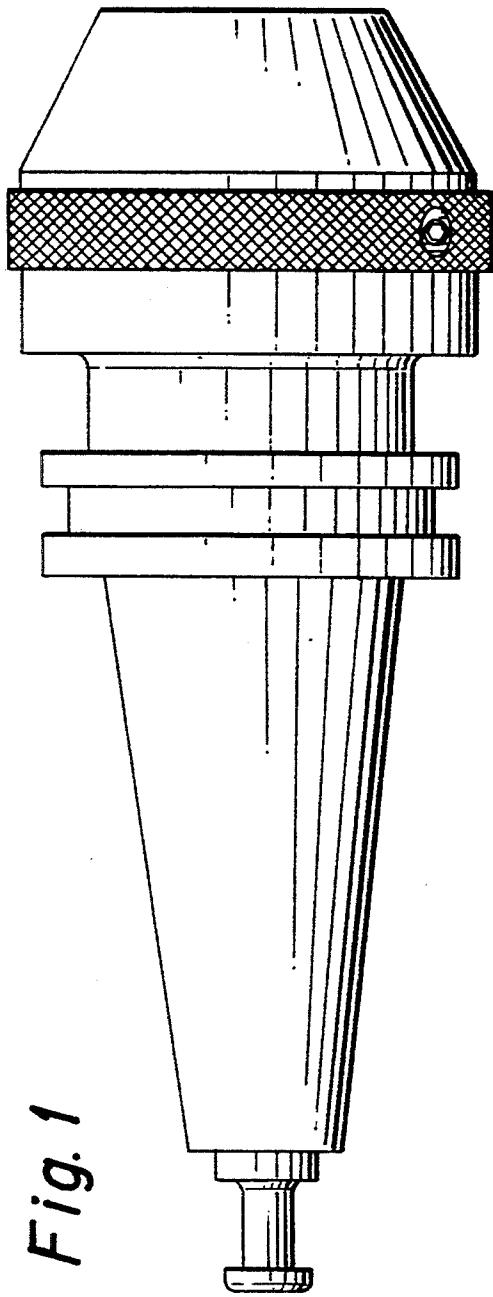

Fig. 1

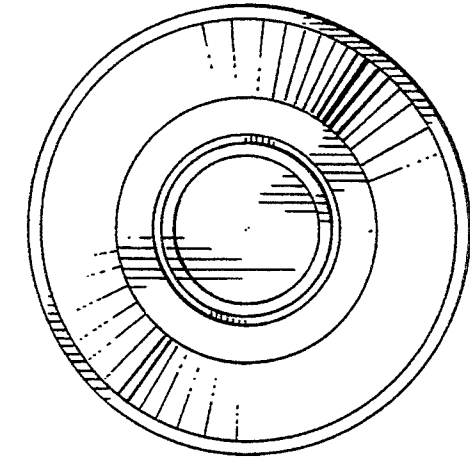

Fig. 2

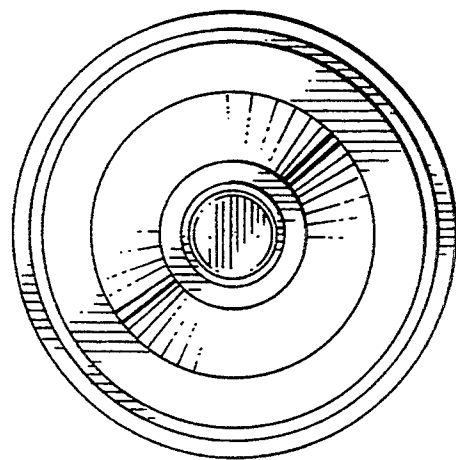

Fig. 3

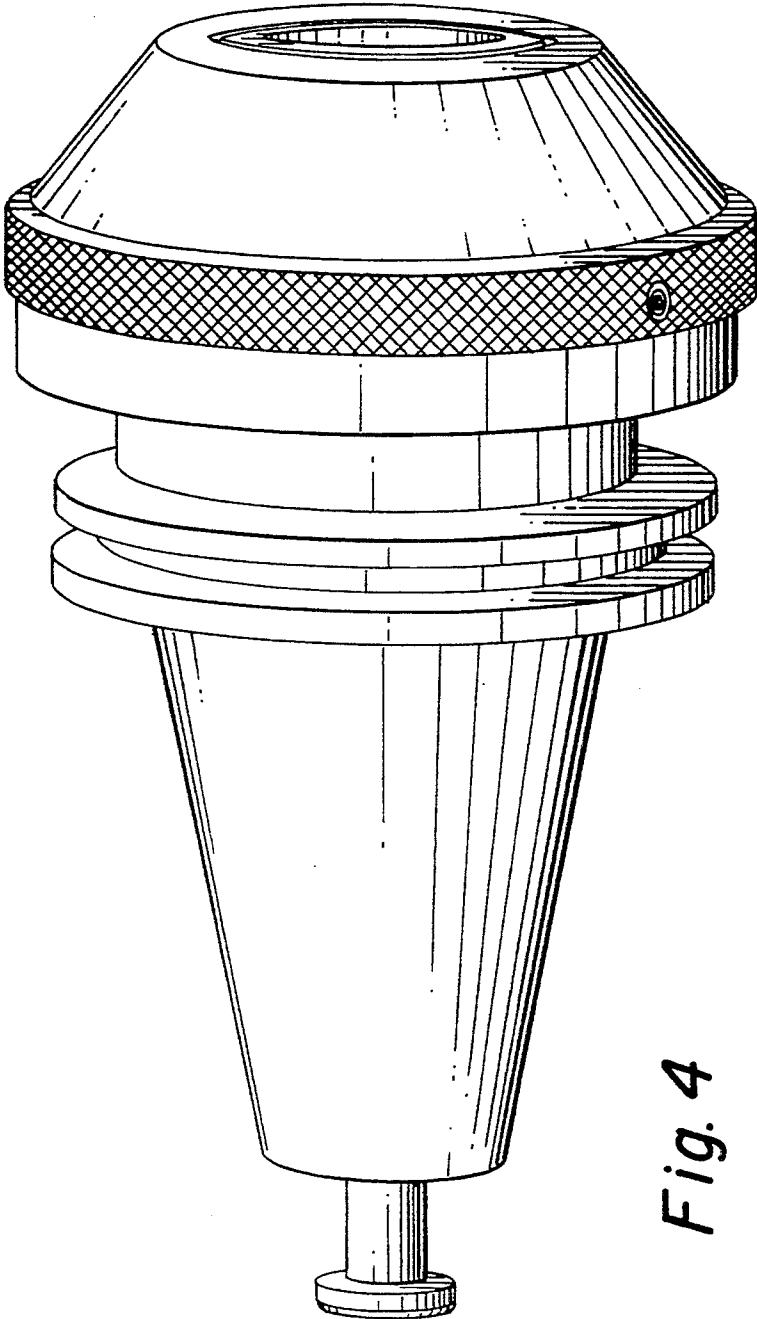

Fig. 4