

J. S. JOHNSTON.
ELECTRIC FUSE AND CUT-OUT.
APPLICATION FILED FEB. 28, 1910.

1,053,096.

Patented Feb. 11, 1913.

2 SHEETS—SHEET 1.

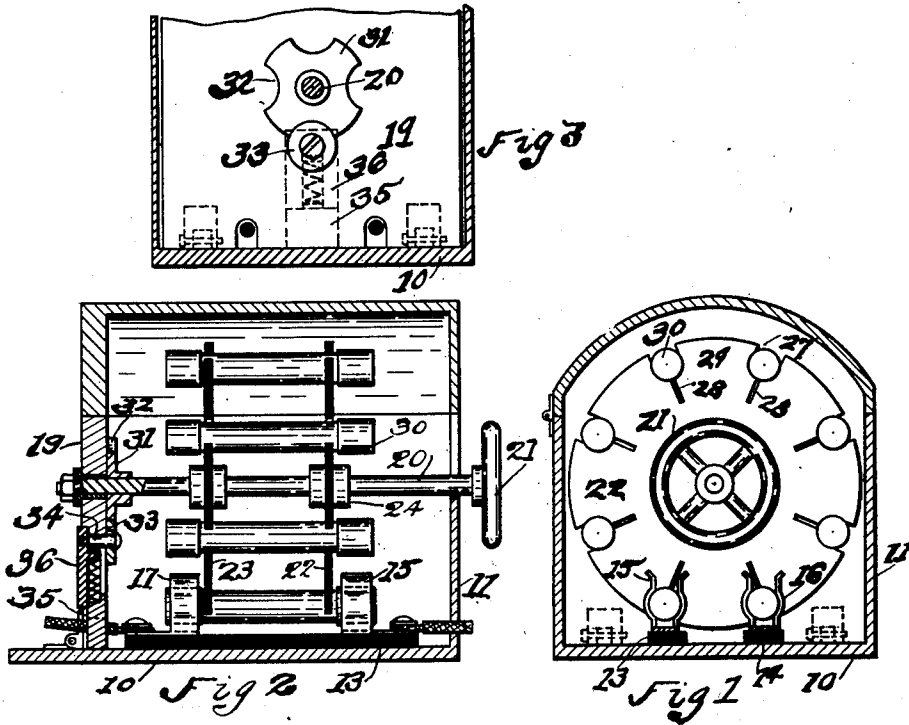

WITNESSES
Robert W. Stewart

G. H. Johnson

INVENTOR:
James S. Johnston
BY
W. M. Carver
HIS ATTORNEY

J. S. JOHNSTON.
 ELECTRIC FUSE AND CUT-OUT.
 APPLICATION FILED FEB. 28, 1910.

1,053,096.

Patented Feb. 11, 1913.

2 SHEETS—SHEET 2.

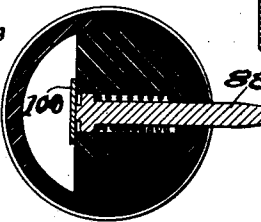
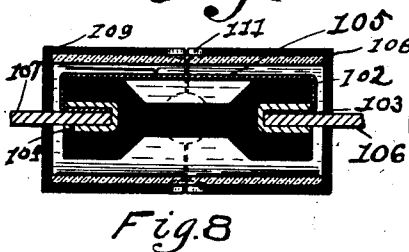
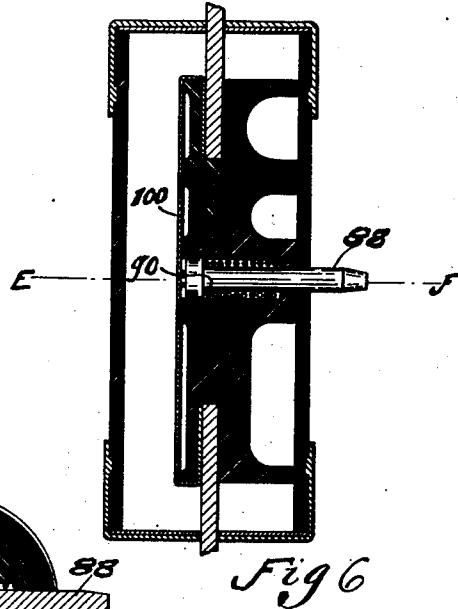
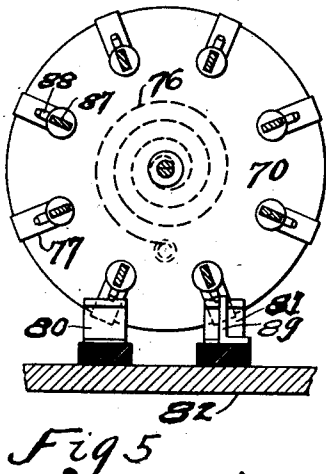
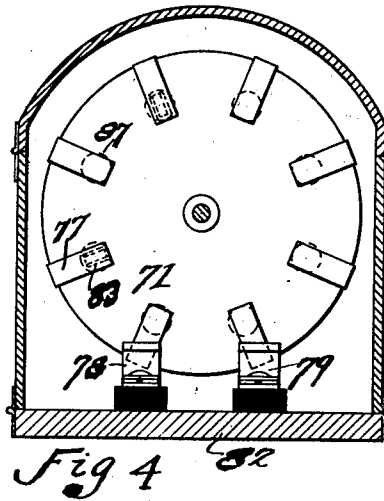
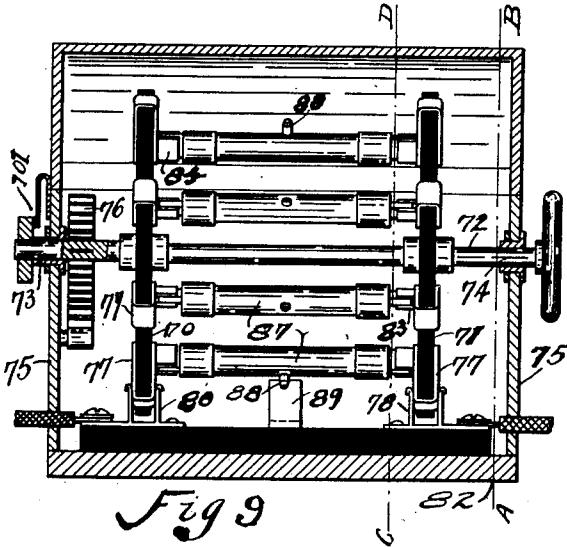

WITNESSES
 Robert W. Stewart

G. A. Stewart

Fig 7

INVENTOR:
 James S. Johnston
 BY
 W. M. Burnham
 HIS ATTORNEY

UNITED STATES PATENT OFFICE.

JAMES S. JOHNSTON, OF UTICA, NEW YORK, ASSIGNOR TO JOHNSTON MANUFACTURING COMPANY, OF UTICA, NEW YORK, A CORPORATION OF NEW YORK.

ELECTRIC FUSE AND CUT-OUT.

1,053,096.

Specification of Letters Patent.

Patented Feb. 11, 1913.

Application filed February 28, 1910. Serial No. 546,454.

To all whom it may concern:

Be it known that I, JAMES S. JOHNSTON, a citizen of the United States, residing in Utica, in the county of Oneida and State of New York, have invented certain new and useful Improvements in Electric Fuses and Cut-Outs, of which the following is a specification.

The invention, of which the accompanying illustration discloses one of the practical forms into which the same may be embodied, constitutes means for providing a combined safety-fuse and cut-out or switch, for use in the art of electricity.

It is an object of the invention to provide for the renewal of fuses, at will, both manually and automatically; to carry a limited supply of fuses for renewal purposes; to insure proper contacts at the renewal of the fuses, and to break the circuit, at will, by the operation of a carrier for the fuses.

Another object of the invention is to displace, at will, the member by which the fuses are carried, whereby, insured from danger of contact, the fuse-carrying-member may be refilled with fuses.

Other objects of the invention may be observed by reference to the following specification, and the drawings that accompany the same.

By reference to the drawings, Figure 1 illustrates in front elevation, and looking into the structure, a fuse-carrier, and fuses in contact. Fig. 2 illustrates a side elevation thereof. Fig. 3 illustrates in elevation, a positioning device to be used in connection with the fuse-carrier. Fig. 4, illustrates means for automatically manipulating the fuse-carrier. Fig. 5 represents a plan view, partly diagrammatic, of the automatically actuated fuse-carrier. Fig. 6 illustrates one form of fuse that may be employed in connection with the fuse-carrier. Fig. 7 represents a sectional view thereof on line EF Fig. 6, Fig. 8 represents another form of fuse that may be employed in connection with this fuse-carrying apparatus. Fig. 9 is a front elevational view, partially in section, showing a modified detail of construction.

Similar characters of reference indicate similar parts in these drawings.

It need not again be stated that such portions as should be insulated, may be con-

structed of any nonconducting material, such, for instance, as fiber.

A base 10, may form a portion of a casing 11, and to it may be secured members 13 and 14, for the support of contact-pieces 15, 16, 17 and 18, which in the present instance, are in the form of clips. Obviously, however, in the course of construction, the members 13 and 14 may be eliminated, and the contact-pieces may be secured to the base 10. These contact-pieces may be of any form of construction, and may be arranged for either hugging the fuses, or otherwise contacting with the same. Movable with relation to the base 10, is a fly 19, which may be said to constitute one of the portions of the casing, and associated with this element is a support 20, which may be provided with means 21 for moving the same—(see Fig. 1). Mounted on this support 20, is a carrier for the fuses, and while this carrier is subject to suitable arrangement or formation within the purview of this invention, the same, in the present instance may comprise two plates 22 and 23, which may or may not be suitably united. In the present instance, as shown, they may be united and supported by a bushing 24, which may be provided with flanges 25 and 26, against which the plates 22 and 23 may rest. These plates may be secured to the flanges, and the bushing of the latter, may be suitably associated with the support 20, for rotation with the latter.

The plates 22 and 23 may be provided with fuse-receiving and holding devices, and these may be provided in any suitable manner within the comprehension of the invention; either by making them of the plates, or associating them therewith. In the present instance, these fuse-receiving and holding devices comprise notches 27, taking into the periphery of the plates at suitable intervals. Preferably, these notches, or such other fuse-retaining devices as might be adopted, may be equidistantly disposed about the periphery of the plates,—it being understood of course, that the arrangement of distances between the fuse-holding portions will be in coincidence with the relative positions of the contact-portions 15, 16, 17 and 18, consequently, according to the relative position of the latter, the number of fuse-retaining-portions on the carrier may be

provided. It will be noted, in this instance, that for the purpose of lending resilience to these fuse-retaining-portions, as shown, the plates may be severed inwardly and radially toward the support 20, and from the base of these portions, as at 28, any two of these cuts 28, allowing lateral movement, under pressure, of a portion 29, between them, whereby the introduction of a fuse may be more easily effected. Fuses 30, are retainable in these portions 27, in the present case, eight in number are disclosed. Therefore, by changing the position of the plates 22 and 23, through the instrumentality of the support 20, with relation to the contacts, four renewals of fuses may be had. Of course, it is evident that more or less of these fuses may be provided, according to the distance apart of the stationary contacts, or according to the capacity in cross-section of the plates 22 and 23. It will be necessary to observe, however, that in placing the stationary contact-pieces, side by side, sufficient distance between them will have to be observed to prevent arcing from one to the other.

Means are provided for so positioning the fuse-carrier that the fuses 30 will positively contact with the contacts on the base. This may be accomplished in any suitable manner. It is arranged for, in the present instance, by providing a star-wheel 31, (which may be affixed to the support 20), with holding portions 32, into which takes a movable member 33, in this case, in the form of a wheel, mounted on a spindle 34, which may be carried by a sliding bearing 35, movable on the fly 19. To induce constant contact between the stop 31 and the wheel 33, a spring 36, urges the wheel to the stop 31.

It will be observed, that if a greater or lesser number of fuses are to be carried by the fuse-carrier, the number of holdings 32, on the star-wheel 31, will be modified accordingly; and it is by no means necessary, because of this description of a special form of positioning and retaining device, that such a structure, for such a purpose, need be adopted in connection with the main idea of the invention.

It is designed to have the support 20, and the carrier, movably mounted relatively to the remaining portion of the structure, in order that the fuses may be connected and disconnected from and with the contacts, whereby to make or break the circuit. In the present case, this fuse-carrying structure and its operating parts, may be mounted on a fly 19, which latter element may be movably mounted relatively to the casing. In this way, the contact may be made and broken, at will, and the carrier may also be shifted for the positioning of a new set of fuses, when others have been blown.

In order to render the invention automatic

in its operation, reference may be had to Figs. 7, 8 and 9, when it will be seen, that means have been provided for causing the fuse-carrying-device to move from position to position, automatically, as the fuses are blown. By reference to these figures, there may be provided a fuse-carrier, which may comprise two plates 70 and 71, which may be mounted on a support 72, which may be journaled, as at 73 and 74, in the body of a casing 75. It is intended that this support 72 should be controlled by any suitable means, such, for instance, as a spring 76, whereby, under conditions of release later on to be explained, the support and the fuse-carrying plates may be shifted, at intervals. The method for attaining this, may be that illustrated in the drawings, or any other suitable means apt to be suggested to the ordinary skilled mechanic. These plates 70 and 71 may be equidistantly provided with contact portions 77 which may be inlaid or otherwise associated with these plates, and these contact-portions 77, are designed to contact with contact-portions 78, 79, 80 and 81 on a base 82 to which the casing 75 is movably associated. Although these contact-pieces 78, 79, 80 and 81 may be suitably formed in any manner, they are shown in the form of bifurcated members, and into the bifurcations pass these contact-pieces 77 during the operation of the device. Extending from these contact-pieces may be clips 83, 84, 85 and 86, to receive fuses 87. The number of fuses 87 that may be loaded into a device of this kind, will depend upon the size of that device, as well as the distance apart of the stationary contacts.

The fuses 81 to be employed in connection with this device may be provided with auxiliary fuses 88, which normally project from the wall of the primary fuse, and are adapted to come into contact with an interrupter 89, suitably disposed in the path of the auxiliary fuse, and in this manner, the entire fuse-carrying-device is held in place against the persuasion of the shifting mechanism during which period also the various current conducting parts are in contact. Should the load exceed the capacity of the primary fuse 87, the auxiliary fuse, 88, which is held outwardly against resistance by a spring 90, by a current conducting element 100, in the fuse, will be allowed to recede from its normal position, as the current conducting element 100 melts or fuses. This, in turn, will cause a release from the stop 89 of the auxiliary fuse 88, and the fuse-carrying device will automatically shift until the next auxiliary fuse comes into contact with the stop 89.

It may be desired to break the contact, at will, in this device, and if so, the casing containing the working parts may be swung from the base, when and during this

operation, and for the purpose of preventing the fuse-carrying device from continually shifting until the energy of the operating mechanism has been expended, a suitable form of breaking mechanism, indicated in a general way by 101, may exert its influence upon the fuse-carrier.

One of the forms of fuses that may be conveniently employed in connection with the portion of the invention first described, may comprise an arbor 102, which may be provided with bifurcations 103 to receive metallic shoes 104, adapted to receive a fuse 105 and the ends of two leads 106 and 107. These leads may be passed through caps 108 and 109, which are to be made of fiber or other non-conducting material, and these caps are designed to almost totally envelop or incase a vitreous material, such as glass, and the parts are so frictionally engaged as to render additional fastening or assembling device unnecessary. These caps meet substantially mid-way of the length of the tube of glass, and are provided with cut out portions 111, whereby to observe, without the removal of the caps, whether or not the fuse has been blown.

It will now be observed that I have provided means for replacing fuses, at will, both by manual and automatic means, from a loaded carrier containing a supply of the fuses, that by the manipulation of this carrier, the fuse box may be converted into a switch and that means are also provided for controlling, automatically the renewal of fuses by the destruction of those in use.

Having thus described the essence of the invention, and referred to one of the practical embodiments thereof, I claim as new:

1. A fuse block, comprising a carrier mounted to be shifted and oscillated, a plurality of fuses carried thereby, means for

operating said carrier to laterally shift one set of fuses out, and another set of fuses into contact, and a set of contacts for a set of fuses.

2. A fuse-block, comprising a laterally-movable carrier mounted to be rotated and oscillated, a plurality of fuses carried thereby, means for operating said carrier to laterally shift blown fuses out of, and new fuses into contact, and contacts for the fuses.

3. A fuse-block, comprising a carrier, pivotal means for supporting the same, a plurality of contacts, fuses supported in pairs by said carrier, and means for removing the blown fuses from the contacts, by changing the axial position of the carrier, and while in such changed position, for shifting new fuses into place to take the contacts.

4. A fuse-block, comprising a movably-supported carrier, means for supporting the same, a plurality of fuses, yielding means in said carrier for detachably supporting said fuses, contacts for said fuses, means for rotating the carrier relatively to said contacts, and means for moving the carrier away from the contacts.

5. A fuse-block, comprising a carrier, means for supporting the same, a plurality of contacts, fuses detachably supported in pairs by said carrier, means for removing the blown fuses from the contacts, by changing the axial position of the carrier, and means for shifting new fuses into place in the carrier, while in such changed position.

Signed at Utica, in the county of Oneida, and State of New York, this nineteenth day of February, 1910.

JAMES S. JOHNSTON.

Witnesses:

FRED. W. BARNACLO,
S. I. DE VINE.