

(19) World Intellectual Property Organization  
International Bureau



(43) International Publication Date  
1 August 2002 (01.08.2002)

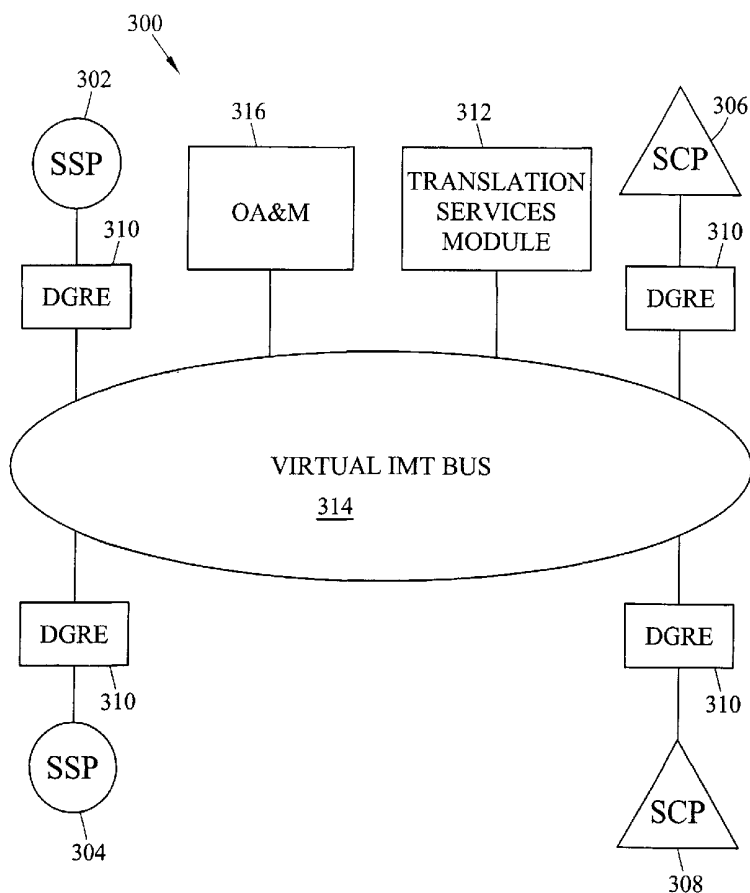
PCT

(10) International Publication Number  
WO 02/060192 A2

- (51) International Patent Classification<sup>7</sup>: **H04Q 3/00** 27516 (US). **MARSICO, Peter, Joseph** [US/US]; 201 Westbrook Drive #D15, Carrboro, NC 27510 (US).
- (21) International Application Number: PCT/US02/01977 **SMITH, Lee, Barfield** [US/US]; 2010 Ramblewood Drive, Apex, NC 27405 (US). **LONG, Virgil, Elmer** [US/US]; 10313 Ray Road, Raleigh, NC 27613 (US).
- (22) International Filing Date: 24 January 2002 (24.01.2002) **HUNT, Gregory, Allen** [US/US]; 111 White Bloom Lane, Morrisville, NC 27560 (US).
- (25) Filing Language: English
- (26) Publication Language: English
- (30) Priority Data: 09/768,881 24 January 2001 (24.01.2001) US
- (71) Applicant (for all designated States except US): **TEK-ELEC** [US/US]; 26580 West Agoura Road, Calabasas, CA 91302 (US).
- (72) Inventors; and
- (75) Inventors/Applicants (for US only): **TINSLEY, Robert, John** [US/US]; 126 Hillspring Lane, Chapel Hill, NC
- (74) Agent: **JENKINS, Richard, E.**; Jenkins & Wilson, P.A., Suite 1400, University Tower, 3100 Tower Boulevard, Durham, NC 27707 (US).
- (81) Designated States (national): AE, AG, AL, AM, AT, AU, AZ, BA, BB, BG, BR, BY, BZ, CA, CH, CN, CO, CR, CU, CZ, DE, DK, DM, DZ, EC, EE, ES, FI, GB, GD, GE, GH, GM, HR, HU, ID, IL, IN, IS, JP, KE, KG, KP, KR, KZ, LC, LK, LR, LS, LT, LU, LV, MA, MD, MG, MK, MN, MW, MX, MZ, NO, NZ, OM, PH, PL, PT, RO, RU, SD, SE, SG, SI, SK, SL, TJ, TM, TN, TR, TT, TZ, UA, UG, US, UZ, VN, YU, ZA, ZM, ZW.

[Continued on next page]

(54) Title: DISTRIBUTED SIGNALING SYSTEM 7 (SS7) MESSAGE ROUTING GATEWAY



(57) Abstract: A distributed gateway includes distributed gateway routing elements co-located with SS7 network elements. Each distributed gateway routing element performs an SS7 routing function, such as an MTP level 3 routing function. The distributed gateway routing elements communicate with each other over a virtual bus that guarantees quality of service for SS7 message packets. Accordingly, the distributed gateway routing elements set quality of service parameters in the SS7 message packets that are forwarded over the virtual bus.

WO 02/060192 A2



**(84) Designated States (regional):** ARIPO patent (GH, GM, KE, LS, MW, MZ, SD, SL, SZ, TZ, UG, ZM, ZW), Eurasian patent (AM, AZ, BY, KG, KZ, MD, RU, TJ, TM), European patent (AT, BE, CH, CY, DE, DK, ES, FI, FR, GB, GR, IE, IT, LU, MC, NL, PT, SE, TR), OAPI patent (BF, BJ, CF, CG, CI, CM, GA, GN, GQ, GW, ML, MR, NE, SN, TD, TG).

**Published:**

— *without international search report and to be republished upon receipt of that report*

*For two-letter codes and other abbreviations, refer to the "Guidance Notes on Codes and Abbreviations" appearing at the beginning of each regular issue of the PCT Gazette.*

DescriptionDISTRIBUTED SIGNALING SYSTEM 7 (SS7) MESSAGE ROUTING  
GATEWAY

5

Related Applications

This application claims the benefit of United States Patent Application Number 09/768,881 filed January 24, 2001, the disclosure of which is incorporated herein by reference in its entirety.

10

Technical Field

The present invention relates to an SS7 message routing gateway. More particularly, the present invention relates to a distributed SS7 message routing gateway.

15

Background Art

The conventional telecommunications network includes two distinct communication pathways or subnetworks—a voice network and a signaling network. These two networks function in a cooperative manner to facilitate a call between users. As implied by its name, the voice network handles the transmission of voice (or user data) information between users. The signaling network has a number of responsibilities, which include call setup, call teardown, and database access features. In simple terms, the signaling network facilitates the dynamic linking together of a number of discrete voice-type communication circuits, such that a voice-type connection is established between the calling and called party. These functions are generically referred to as call setup and call teardown. Additionally, the signaling network provides a framework through which non-voice related information may be transported, with this data and transport functionality being transparent to the users. This signaling technique is often referred to as out-of-band signaling, where the term “band” implies voice band. Common examples of services provided via the signaling network include 800 number database services, calling card verification services, and caller

-2-

ID services. The original motivation for employing such an out-of-band signaling technique was to provide telecommunications service agents with an infrastructure that allowed for new and enhanced revenue producing services, such as 800 database access, call waiting, and caller ID services  
5 and to avoid tying up expensive voice trunks with signaling traffic.

From a hardware perspective, an SS7 network includes a plurality of SS7 nodes, generically referred to as signaling points (SPs), that are interconnected using signaling links, also referred to as SS7 links. At least three types of SPs are provided in an SS7 network: service switching points  
10 (SSPs), signal transfer points (STPs) and service control points (SCPs).

An SSP is normally installed in Class 4 tandem or Class 5 end offices. The SSP is capable of handling both in-band signaling and SS7 signaling. An SSP can be a customer switch, an end-office, an access tandem and/or a tandem. An STP transfers signaling messages from one signaling link to  
15 another. STPs are packet switches and are generally installed as mated pairs. Finally, SCPs control access to databases such as 800 number translation, 800 number carrier identification, credit card verification, etc. SCPs are also deployed in pairs.

Signaling links are transmission facilities used to connect SPs  
20 together. Conventional signaling links are dedicated bidirectional facilities operating at 56 kbps in the U.S. and Canada and at 64 kbps when clear channel capability is deployed. Normally, every link has a mate for redundancy and enhanced network integrity.

In order to ensure consistent and reliable communication across the  
25 signaling network infrastructure, a common or standard digital signaling protocol was established by the ITU-TS in the mid-'60s, and this protocol was known as Signaling System 6. By the mid-'80s the protocol had evolved into a slightly more sophisticated system known as Signaling System 7 (SS7). As a protocol, SS7 defines the hierarchy or structure of the  
30 information contained within a message or data packet. This internal data structure is often referred to as the protocol stack, which is comprised of a

number of well defined strata or layers. In general terms, the SS7 protocol stack consists of 4 levels or layers:

- 5 (1) the physical layer
- (2) the data link layer
- (3) the network layer
- (4) the user and application part layer

10 The physical layer is the lowest or most fundamental layer and is the first layer that is used to interpret and process an incoming message. This layer is concerned with determining and/or providing the electrical characteristics needed to transmit the digital data over the interface being used. Following interpretation/processing, the incoming message is passed up the stack to the data link layer.

15 The data link layer (MTP layer 2) resides adjacent and above the physical layer and is responsible for providing the SS7 network with error detection/correction and properly sequenced delivery of all SS7 message packets. Following interpretation/processing, the incoming message is passed up the stack to the network layer.

20 The network layer (MTP layer 3) resides adjacent and above the data link layer and is responsible for message packet routing, message packet discrimination, and message packet distribution. Functionally, message discrimination determines to whom the message packet is addressed. If the message contains the local address (of the receiving node), then the message is passed on to message distribution. If the message is not  
25 addressed to the local node, then it is passed on to the message router. Following interpretation/processing, the incoming message is passed up the stack to the user part layer only if the message was destined to that node.

30 The user and application part layer resides adjacent and above the network layer and actually consists of several distinct parts. The parts may include mobile application part (MAP), radio access network application part

-4-

(RANAP), transaction capabilities application part (TCAP), ISDN user part (ISUP), telephone user part (TUP), and broadband ISDN user part (B-ISUP).

While the SS7 network has functioned successfully for a number of years, such a network typically includes centralized nodes that make routing  
5 decisions which can have some disadvantages. Such disadvantages include expense due to processing requirements of centralized nodes, high-traffic volume at the centralized nodes, and possible network outage if one or more of the centralized nodes fails.

Figure 1 is a block diagram of a conventional SS7 network in which a  
10 centralized node makes routing decisions. In Figure 1, SSPs **100** and **102** communicate with SCPs **104** and **106** through a mated pair of STPs **108** and **110**. STPs **108** and **110** are located at a central point in the network and receive traffic from many SSPs and SCPs. STPs **108** and **110** make routing decisions for SS7 messages and route the messages to their intended  
15 destinations. STPs **108** and **110** may also translate the protocol of incoming SS7 messages if the destination node is of a different protocol than the sending node.

Because of the central location of STPs **108** and **110** and because of all of the tasks required to be performed by STPs **108** and **110**, STPs **108**  
20 and **110** include an extremely complex parallel architecture for handling all of these functions. An example of such an STP with a highly parallel architecture is the EAGLE<sup>®</sup> STP available from Tekelec of Calabasas, California.

Figure 2 is a block diagram of a conventional data network. In the  
25 data network, routers **200**, **202**, **204**, and **206** are co-located with end offices **208** and **210** and databases **212** and **214**. Routers **200**, **202**, **204**, and **206** are IP routers. Routers **200**, **202**, **204**, and **206** are only capable of making IP routing decisions. Thus, packets incoming from elements **208**, **210**, **212**, and **214** are in IP format and packets outgoing from routers **200**, **202**, **204**,  
30 and **206** are also in IP format.

While IP networks provide a number of advantages, IP networks do not include the inherent reliability or stability of a conventional SS7 network.

As discussed above, the conventional SS7 network architecture includes centralized routing elements which are expensive, complex, and subject to high-traffic volumes. Thus, there exists a need for a distributed SS7 gateway that avoids at least some of the difficulties associated with the prior art.

#### Disclosure of the Invention

According to one aspect, the present invention includes a distributed SS7 gateway. The distributed SS7 gateway includes a plurality of distributed gateway routing elements. Each of the distributed gateway routing elements may be co-located with an SS7 node, such as an SSP or an SCP. Each of the distributed gateway routing elements performs an SS7 routing function, such as an MTP3 routing function. The distributed gateway routing elements route messages to other distributed gateway routing elements or to a translation services node for further processing. Such routing is similar to the internal routing performed by an SS7 STP or signaling gateway. As used herein, the phrase "signaling gateway" refers to a network node capable of routing telephony-related signaling messages between other network nodes and that is also capable of performing protocol translations for the signaling messages. However, because the functional components of the distributed gateway are co-located with network endpoints, rather than centrally located in a single node, the possibility of a complete network outage caused by failure of a single node is reduced.

According to another aspect, the invention may include an operations, administration, and maintenance (OA&M) node. The OA&M node may establish initial DGRE routing tables.

According to yet another aspect, the present invention includes a translation services module. The translation services module may be centrally located to perform centralized functions, such as global title translation, protocol conversion, and number portability.

Accordingly, it is an object of the present invention to provide a distributed message routing gateway that avoids at least some of the

difficulties associated with conventional centralized routing nodes and with conventional IP telephony networks.

Some of the objects of the invention having been stated hereinabove, other objects will be evident as the description proceeds, when taken in  
5 connection with the accompanying drawings as best described hereinbelow.

#### Brief Description of the Drawings

Preferred embodiments of the invention will now be explained with reference to the accompanying drawings:

10 Figure 1 is a block diagram of a conventional SS7 network having a centralized routing element;

Figure 2 is a block diagram of a conventional data network; and

Figure 3 is a block diagram of a network including a distributed message routing gateway according to an embodiment of the present  
15 invention;

Figure 4(A) is a block diagram illustrating IPv6 header fields including the flow label field that may be used to provide quality of service for call signaling messages routed between distributed gateway routing elements according to embodiments of the present invention;

20 Figure 4(B) is a block diagram of sub-field of the flow label field illustrated in Figure 4(A);

Figure 5 is a block diagram of a type of service field from an IPv6 header that may be used to provide quality of service for call signaling messages routed between distributed gateway routing elements according to  
25 an embodiment of the present invention;

Figure 6(A) is a block diagram of an IP packet including an MPLS header that may be used to provide quality of service for call signaling messages routed between distributed gateway routing elements according to an embodiment of the present invention;

30 Figure 6(B) is a block diagram of fields in an MPLS header that may be used by distributed gateway routing elements to provide quality of service



for SS7 messages routed between distributed gateway routing elements according to an embodiment of the present invention;

Figure 7 is a block diagram illustrating an exemplary internal architecture of a distributed gateway routing element according to an  
5 embodiment of the present invention;

Figure 8 is a flow chart illustrating exemplary steps that may be performed by a distributed gateway routing element in processing an incoming SS7 message from an SS7 network element and forwarding the SS7 message via the virtual IMT bus; and

10 Figure 9 is a flow chart illustrating exemplary steps that may be performed by a distributed gateway routing element in processing a message received via virtual IMT bus and routing the message to an SS7 network element via an SS7 signaling link.

15 Detailed Description of the Invention

Rather than locating all of the SS7 routing architecture in a centralized network element, such as a signal transfer point or signaling gateway, embodiments of the present invention include a plurality of distributed gateway routing elements that are co-located with other SS7 network  
20 elements. The distributed gateway routing elements function collectively as a signal transfer point or signaling gateway. However, because the distributed gateway routing elements are not located together in a single location, the processing load on each element is reduced and the possibility of a complete network failure is reduced.

25 Figure 3 is a block diagram of a communications network including a distributed gateway according to an embodiment of the present invention. Referring to Figure 3, network **300** includes conventional SS7 network elements, such as SSPs **302** and **304** and SCPs or application servers **306** and **308**. However, unlike a conventional SS7 network, network **300** does  
30 not include a conventional centralized signal transfer point or signaling gateway. In order to perform the functions provided by a conventional signal transfer point or signaling gateway, network **300** includes a plurality of

distributed gateway routing elements **310** that are co-located with SS7 signaling points **302**, **304**, **306**, and **308**. Each of the distributed gateway routing elements **310** is capable of sending and receiving SS7 messages via an SS7 link that connects each distributed gateway routing element to its  
5 respective SS7 network element. In addition, each distributed gateway routing element **310** communicates with other distributed gateway routing elements and with central distributed gateway routing element **312** via virtual interprocessor message transport (IMT) bus **314**.

Although in the illustrated embodiment each DGRE **310** is connected  
10 to a single SS7 signaling point, the present invention is not limited to such an embodiment. For example, in an alternative embodiment of the present invention, each DGRE **310** may be associated with more than one SS7 network element. In addition, DGREs **310** may be connected to network elements other than those illustrated in Figure 3, such as softswitches and  
15 media gateway controllers.

Virtual IMT bus **314** performs functions similar to a conventional interprocessor message transfer bus present in an SS7 signal transfer point, such as the EAGLE<sup>®</sup> STP available from Tekelec. Such functions include reliable delivery of SS7 messages to modules for outbound processing,  
20 meeting SS7 message timing requirements, and carrying network management messages, such as routing table establishment and maintenance-related messages between distributed gateway routing elements. However, unlike the conventional IMT bus, virtual IMT bus **314** spans large geographic distances, thus making meeting the SS7 reliability  
25 and timing requirements difficult. In order to meet these requirements, it is envisioned that a protocol that guarantees quality of service for each connection may be used. An example of such a protocol may be Internet Protocol version 6 (IPv6).

In IPv6, a new field, referred to as a flow label, is provided in the IPv6  
30 packet header and may be used by distributed gateway routing elements and IP routers that interconnect distributed gateway routing elements to provide quality of service for call signaling messages traveling between

distributed gateway routing elements. For call signaling packets, end-to-end delay may be one of the quality of service parameters that is guaranteed. Another quality of service parameter important in transmitting SS7 message packets via virtual IMT bus **314** may be reliability. Both of these parameters  
5 may be set for call signaling packets transmitted between distributed gateway routing elements using the flow label in the IPv6 packet header.

More particularly, distributed gateway routing elements **310** may encapsulate SS7 call signaling messages in IP datagrams and set one or more quality of service parameters in the datagrams to notify IP routers that  
10 interconnect distributed gateway routing elements **310** of the quality of service expected for these packets. The manner in which IP routers treat such packets depends on the routing algorithm used and is beyond the scope of this disclosure. What is important for purposes of the present invention is that the distributed gateway routing elements set quality of  
15 service parameters in the call signaling packets to be transmitted over virtual IMT bus **314** so that the interconnecting IP routers can give such packets the appropriate priority.

Figures 4(A) and 4(B) respectively illustrate examples of an IPv6 header and a flow label field of the IPv6 header. In Figure 4(A), IPv6 header  
20 **400** includes version field **402** indicates the IP version. Flow label field **404** contains parameters used by routers to provide quality of service. Payload length field **406** specifies the length of the IPv6 payload. Next header field **408** specifies the type of any extension headers that follow the base header. Extension headers are optional in IPv6 and are not of importance to  
25 explaining the present invention. Hop limit field **410** provides a strict bound on the maximum number of hops a datagram can make before being discarded. Source address field **412** and destination field **414** each contain 128-bit IP addresses, thus greatly increasing the IP address space over conventional IPv4.

30 Referring to Figure 4(B), flow label field **404** is divided into a T-class field **416** and a flow identifier field **418**. T-class field **416** specifies the traffic class for the datagram. In the illustrated embodiment, T-class field **416** is a

-10-

4-bit field. Values 0-7 of T-class field **416** are used to specify the time sensitivity of flow-controlled traffic. Values 8-15 are used to specify a priority for non-flow-controlled traffic. The remaining 24-bit flow identifier field contains a source-chosen flow identifier for a given traffic stream. Thus, in order to guarantee quality of service for packets routed between distributed gateway routing elements, a source distributed gateway routing element may select a flow identifier for SS7 signaling message traffic and assign a traffic class value indicating high time sensitivity. Using these parameters, a source distributed gateway routing element may forward the SS7 signaling message to another distributed gateway routing element. The receiving distributed gateway routing element may send a response back to the sending distributed gateway routing element using the same flow identifier and T-class. Routers in between the two distributed gateway routing elements may utilize the T-class and flow identifier values to ensure that packets are delivered between the distributed gateway routing elements within a predetermined time period.

The present invention is not limited to using flow identifier field in an IPv6 header to provide quality of service for SS7 messages traveling between distributed gateway routing elements. For example, in an alternative embodiment, the type of service (TOS) field in the IPv4 header may be used to provide quality of service between distributed gateway routing elements. Figure 5 illustrates an example of the type of service field in the IPv4 header. In Figure 5, type of service field **500** includes a precedence field **502**, transport type bits **504**, and unused portion **506**. Precedence field **502** is used to specify the precedence of the datagram. D, T and R bits are used to specify delay, throughput, and reliable transport, respectively. For example, if the D bit is set, the datagram is requesting low delay transport. If the T bit is set, the datagram is requesting high throughput. If the R bit is set, the datagram is requesting high reliability. By specifying combinations of precedence and transport bits, distributed gateway routing elements may request a specified quality of service for SS7 call signaling messages routed between distributed gateway routing

elements. For example, a distributed gateway routing element may set a precedence value in precedence field **502** indicating high priority and set the delay bit to ensure that a datagram is delivered on time. Routers between the distributed gateway routing elements may use the TOS field to prioritize

5 SS7 message packets and guarantee one or more QoS parameters, such as delay or reliability.

Another example of a mechanism for providing quality of service for call signaling packets transmitted between distributed gateway routing elements is to use multi-protocol label switching (MPLS). MPLS is used by

10 routers to switch rather than route packets. Switching is faster than routing because it is a layer 2, rather than a layer 3 function of the IP protocol stack. When an incoming packet includes an MPLS header, the receiving router switches the packet based on the label in the MPLS header, rather than routing the packet based on its IP address. The router also changes the

15 label in the MPLS header to a new label, which the next router uses to switch the packet to the appropriate outgoing link. Unlike conventional IP routing, MPLS routes are established in advance before any data is transferred. Since routes are established in advance, MPLS can be used to establish forwarding equivalence classes whereby classes of IP packets are

20 guaranteed the same quality of service.

Forwarding equivalence classes can be used to guarantee special treatment of MPLS-encapsulated SS7 packets transmitted between distributed gateway routing elements according to embodiments of the present invention. For example, distributed gateway routing elements **310**

25 may add MPLS labels to outgoing IP-encapsulated SS7 call signaling message packets. The MPLS label added by the distributed gateway routing element determines the forwarding equivalence class for the SS7 signaling message packets at the time of network ingress. Routers that interconnect the distributed gateway routing elements examine only the MPLS label to

30 determine the outgoing link for the MPLS-encapsulated SS7 message. The label-switched path between distributed gateway routing elements may be

agreed upon in advance of transmission to determine the quality of service for SS7 signaling message packets.

Figure 6(A) illustrates an example of an IP packet including an MPLS header. In the illustrated example, IP packet **600** includes an IP header **602**,  
5 an MPLS header **604**, a TCP header **606**, and a payload **608**. For an SS7 call signaling message routed between distributed gateway routing elements, IP header **602** may contain the IP address of one of the distributed gateway routing elements. MPLS header **604** may contain a service class identifier that identifies a class of service to be given to IP  
10 packet **600**. For SS7 call signaling messages, the class of service is preferably a high class of service that has low delay and high reliability. TCP header **606** contains transport layer information such as sequence numbers for a TCP string that may be established between distributed gateway routing elements. Finally, payload field **608** contains some or all of the SS7  
15 call signaling packet. Thus, a variety of methods may be used to guarantee quality of service for call signaling packets routed between distributed gateway routing elements.

Figure 6(B) is a block diagram of the fields of MPLS header **604** illustrated in Figure 6(A). In Figure 6(B), MPLS header **604** includes a label  
20 field **610**, an experimental use field **612**, a bottom of stack bit **614**, and a time to live field **616**. As discussed above, label field **610** contains the MPLS label that is assigned by the ingress router, i.e., the distributed gateway routing element, to determine the path forwarding equivalence class of the packet. Distributed gateway routing elements **310** may initialize  
25 experimental use field **614** to a value that indicates a quality of service to be given to packets within a forwarding equivalence class. Bottom of stack field and time to live field are not of importance in explaining the present invention. Further details of the multi-protocol labels switching architecture can be found in Internet Engineering Task Force (IETF) Internet draft: *Multi-*  
30 *Protocol Label Switching Architecture*, draft-ietf-mpls-arch-07.txt, July 2000, the disclosure of which is incorporated herein by reference in its entirety.

-13-

Referring back to Figure 3, translation services module **312** provides translation services to distributed gateway routing elements **310**, such as protocol translation, number portability, directory number to IP address mapping, and global title translation. Translation service module **312** may be  
5 a single node dedicated to providing more than one of the above-  
enumerated translation services. Alternatively, translation services module **312** may be a single node dedicated to performing one of the above-  
enumerated translation services. In the single-service case, a plurality of translation services modules **312** may be coupled to virtual IMT bus **314** for  
10 performing the various translation services. In both the single and multiple-  
service cases, redundant translation services modules **312** may be provided for load sharing and reliability. Finally, OA&M module **316** performs administrative functions for the distributed gateway routing elements, such as database provisioning.

15 DGRE Architecture

Figure 7 is a block diagram of an exemplary internal architecture for a distributed gateway routing element according to an embodiment of the present invention. In Figure 7, distributed gateway routing element includes processes for implementing an SS7 protocol stack and processes for  
20 communicating via virtual IMT bus **314**. From a hardware perspective, each DGRE **310** may be a general or special purpose computer having at least one SS7 interface and at least one interface to virtual IMT bus **314**. With regard to SS7 processing, each distributed gateway routing element **310** includes MTP level 1 and 2 processes **700** and **702** for performing SS7 MTP  
25 layer 1 and 2 functions, such as sequencing and error correction. Input/output queue **704** buffers messages before processing by higher level functions. Message handling and discrimination (HMDC) process **705** determines whether a message is addressed to this distributed gateway **300** (illustrated in Figure 3) or to another distributed gateway. This determination  
30 may be made based on the destination point code and/or other fields, such as the circuit identification code (CIC), in a received SS7 message. Message handling and distribution (HMDT) process **706** routes messages

-14-

that are destined for this distributed gateway **300** to an element of this distributed gateway, such as translation services module **310**, for further processing.

HMDT process **706** functions similarly to the HMDT process in the  
5 above-referenced EAGLE<sup>®</sup> STP. However, unlike the HMDT process in the  
conventional EAGLE<sup>®</sup> STP which distributes messages internally in the STP,  
HMDT process **706** distributes messages to DGREs that are part of the  
same distributed gateway via virtual IMT bus **314** which may span a large  
geographic area. Thus, in Figure 3, it is envisioned that DGREs **310** may  
10 share a single SS7 point code. A message received by any one of DGREs  
**310** via one of the SS7 signaling links that is addressed to the point code  
distributed gateway **300** may be internally routed to one of the other DGREs  
via virtual IMT bus **314**. Thus, DGREs **310** function collectively as a signal  
transfer point without the requirement of a centralized node.

15

#### Gateway Screening

Additional functions that may be performed by distributed gateway  
routing elements **310** include gateway screening, message copying, and  
overriding DPC routing. Gateway screening is a function performed by  
DGREs **310** to screen messages based on one or more parameters in the  
20 messages. For example, DGREs **310** may each include a gateway  
screening process that screens incoming SS7 messages based on  
parameters, such as originating point code, destination point code, and/or  
CIC code. In one screening example, if a message is from an allowed  
originating point code, distributed gateway routing elements **310** may allow  
25 the message into the network comprising virtual IMT bus **314**. If a message  
is not from an allowed originating point code, the message may be  
discarded.

#### Message Copying

Message copying refers to copying all or portions of selected  
30 message signal units (MSUs) received by a DGRE. For example, it may be  
desirable to capture all MSUs directed to a database, such as SCP **306** for  
accounting or billing purposes. For network monitoring purposes, it may be



desirable to record copies of or a count of MSUs received by DGREs **310**. The copies MSU information received by DGREs **310** may be forwarded to an external node for further processing. Such forwarding may be accomplished by sending the message copies in Internet protocol packets to  
5 the external node via a wide or local area network.

#### Overriding Point Code Routing

Overriding point code routing is another function that may be performed by DGREs **310**. For example, as mentioned above, DGREs may route messages to other DGREs based on the destination point code, CIC  
10 code, or other parameters in received SS7 MSUs. This is the normal DPC routing function. In addition to this type of routing, DGREs **310** may also override normal DPC routing based on the presence of one or more parameters in a message. One example in which it may be desirable to override normal DPC routing is when providing triggerless number portability  
15 service. According to triggered number portability service, an SSP, such as SSP **304**, may receive a call to a ported number. In such a situation, SSP **304** would formulate a transaction capabilities application part (TCAP) query to a number portability database, such as SCP **306**. The query would be routed to SCP **306** via DGREs **310**. The response to the query containing  
20 the real directory number corresponding to the ported number is sent from SCP **306** to SSP **304** via DGREs **310**. SSP **304** uses the real directory number in the response to set up a call with the called party by formulating an ISDN user part (ISUP) message addressed to the called party end office and containing the subscriber's real directory number.

25 According to triggerless number portability, when SSP **304** receives a call to a ported number, SSP **304** sends an ISUP message to the destination SSP associated with the dialed directory number via distributed gateway **300**. One of the distributed gateway routing elements **310** receives the message, and determines that the message is related to a call to a  
30 subscriber whose number has been ported to another service area. In response to determining that the number has been ported, the receiving DGRE **310** forwards the message to translation services module **310**, which

translates the DPC in the message to the DPC of the SSP servicing the subscriber's new service area, inserts the new directory number in the message, and forwards the message to the appropriate destination SSP. Thus, DGREs **310** according to embodiments of the present invention are  
5 capable of performing both triggered and triggerless number portability routing operations.

#### Virtual IMT Bus Communications Processes

In order to communicate with other distributed gateway routing elements via virtual IMT bus **314**, distributed gateway routing element  
10 includes virtual IMT bus address translator **708** and quality of service manager **710**. Virtual IMT bus address translator **708** may translate between SS7 and the protocol used on virtual IMT bus **314**. As stated above, exemplary protocols that may be used on virtual IMT bus **314** include IP version 6 including flow labels, IP version 4 including the type of service  
15 field, and MPLS. Thus, virtual IMT bus address translator is preferably capable of formulating the appropriate header including the quality of service parameters and forwarding the packets to other distributed gateway routing elements via IMT bus **314**. Quality of service manager **710** may determine the quality of service required for a given SS7 packet and instruct virtual IMT  
20 bus address translator **708** to set the appropriate parameters in the IP and/or MPLS headers. For example, if the packet is an ISUP call signaling packet, quality of service manager **710** may instruct virtual IMT bus address translator **708** to assign a high priority to the packet, using one or more of the above-described parameters, with regard to end-to-end delay.

25 Virtual IMT bus address translator **708** preferably also receives messages from virtual IMT bus **314**, translates the messages from the virtual IMT bus protocol to SS7, and passes the messages to outbound SS7 routing process **712**. Outbound SS7 routing process **712** selects the outgoing SS7 link based on the SS7 point code.

30 Figure 8 is a flow chart illustrating exemplary steps that may be performed by a distributed gateway routing element according to an embodiment of the invention in routing an outgoing SS7 message packet

over virtual IMT bus **314**. Referring to Figure 8, in step **ST1**, a distributed gateway routing element receives an SS7 call signaling message from an SS7 network element. For example, a distributed gateway routing element may receive an SS7 message from an SSP, an SCP, or an STP. In step  
5 **ST2**, distributed gateway routing element SS7-routes the call signaling message. SS7-routing the call signaling message may include examining the destination point code and other fields in the MTP layer 3 portion of the message to determine the destination SS7 network element. Once the destination SS7 network element is determined, in step **ST3**, the distributed  
10 gateway routing element determines the required quality of service parameters for the call signaling message. Determining the required quality of service parameters may include examining the SS7 message type to determine the time sensitivity of the message in accordance with SS7 standards.

15 In step **ST4**, the distributed gateway routing element sets the appropriate quality of service parameters in the virtual IMT bus packet. As discussed above, these parameters may include parameters in the flow label of an IPv6 header if the virtual IMT bus is implemented using IP version 6. Additional alternatives for providing quality of service may include setting the  
20 TOS field in the IPv4 header or adding an MPLS header to the SS7 message before sending the message over the virtual IMT bus.

In step **ST5**, the distributed gateway routing element sends the SS7 call signaling message to the distributed gateway routing element associated with the destination SS7 network element via the virtual IMT bus. For  
25 example, the destination SS7 network element may be a service control point. In this example, the SS7 call signaling message is delivered to the distributed gateway routing element associated with the service control point via virtual IMT bus **314**. The routers between the distributed gateway routing elements may utilize the quality of service parameters in the virtual IMT bus  
30 packet that carries the SS7 message to provide the desired quality of service. As a result, SS7 messages can be delivered on time and with sufficient reliability in accordance with SS7 standards.

Figure 9 is a flow chart illustrating exemplary steps that may be performed by a distributed gateway routing element in processing and SS7 message packet received via virtual IMT bus 314. Referring to Figure 9, in step **ST1**, distributed gateway routing element 310 receives a virtual IMT bus formatted call signaling message. In step **ST2**, the distributed gateway routing element removes the virtual IMT bus header from the call signaling message. In step **ST3**, the distributed gateway routing element adds any needed SS7 message headers. Finally, in step **ST4**, the distributed gateway routing element routes the SS7 message to the destination SS7 network via an SS7 signaling link.

Although the routing example described with respect to Figures 8 and 9 illustrates the steps for routing an SS7 signaling message from an SS7 network element, to a distributed gateway routing element, through virtual IMT bus 314, through another distributed gateway routing element, and to a destination SS7 network element, the present invention is not limited to such an embodiment. For example, in an alternative embodiment, an SS7 call signaling message may be routed from a source SS7 network element to a distributed gateway routing element, through virtual IMT bus 314, and to translation services module 312. An example of a message requiring such translation is an SCCP message requiring global title translation. Translation services module 312 receives the call signaling message, removes the virtual IMT bus header, performs the required translation service, and routes the message to the distributed gateway routing element associated with the destination SS7 network element. Translation services module 312 may include a quality of service manager process similar to that described with regard to the distributed gateway routing elements for setting the appropriate parameters in the outbound virtual IMT bus message so that the message will be delivered to its intended destination with the required quality of service.

#### 30 DGRE Routing Tables and Route Update Message Exchange

According to another aspect of the invention, the distributed gateway routing elements exchange routing information via virtual IMT bus 314. More

particularly, distributed gateway routing elements **310** illustrated in Figure 3 may initially receive a routing table for routing messages to SS7 network elements from OA&M module **316**. Table 1 shown below is an example of some of the information that may be included in the routing table.

5

Point Code	Destination Address	Link Status	Cost	Domain
1-1-1	1.1.1.1	Up	1	ANSI
1-1-2	1.1.1.2	Up	2	ANSI
1-1-3	1.1.1.3	Up	2	ITU
1-1-4	1.1.1.4	Down	INFINITE	ANSI

TABLE 1: DGRE Routing Table

In Table 1, SS7 point codes are translated to destination addresses, which in the illustrated example are IP addresses. However, the present invention is not limited to using IP addresses to locate distributed gateway routing elements. For example, as discussed above, in an alternative embodiment, MPLS labels may be used. In addition, other fields in incoming messages in addition to the point code may be used in routing the messages.

In Table 1, the status field indicates a status of a link associated with a distributed gateway routing element. The cost field allows the sending distributed gateway routing element to determine the least cost path over which the message should be routed. Finally, the domain field indicates the domain of the destination SS7 network element.

Routing tables may be initially loaded onto distributed gateway routing elements through OA&M module **316** via virtual IMT bus **314**. Once the routing table is loaded, it is desirable to maintain current information in the routing table with regard to link status and cost. In order to maintain link status and cost information in distributed gateway routing element routing tables, distributed gateway routing elements **310** may exchange route update messages via virtual IMT bus **314**. For example, when a link goes

25

down between a DGRE and its associated SS7 network element, the DGRE may notify the other DGREs that the status of the link is down. In addition, if the cost associated with routing a message to an SS7 network element changes, the DGRE associated with the SS7 network element may notify the  
5 other DGREs of the change in cost in order for them to choose the least cost path for routing messages to that SS7 network element. By exchanging network management messages via virtual IMT bus 314, distributed gateway routing elements 310 maintain current routing information in their respective routing tables in a manner similar to a centralized node, such as a signal  
10 transfer point.

Thus, the present invention includes a distributed gateway that includes multiple routing elements that are co-located with SS7 network elements. The distributed gateway routing elements communicate with each other via a virtual IMT bus that guarantees a specified quality of service for  
15 SS7 call signaling messages. Because the distributed gateway routing elements are located at the individual nodes rather than in a centralized network node, the probability of a complete network outage due to failure of one of the distributed gateway routing elements is decreased. In addition, the expense of providing SS7 routing services can be distributed among  
20 owners of the various SS7 network elements. Finally, distributed gateway routing elements according to embodiments of the present invention are capable of selecting quality of service parameters for outgoing SS7 message packets to ensure on-time, reliable delivery of SS7 message packets.

It will be understood that various details of the invention may be  
25 changed without departing from the scope of the invention. Furthermore, the foregoing description is for the purpose of illustration only, and not for the purpose of limitation—the invention being defined by the claims.

CLAIMS

What is claimed is:

1. A distributed call signaling message routing gateway comprising:
  - 5 (a) a first distributed gateway routing element including a first interface for sending SS7 call signaling messages to and receiving SS7 call signaling messages from a first SS7 network element and for performing SS7 routing functions for the SS7 messages received from the first SS7 network element and a second interface for sending the SS7-routed messages over a virtual bus and for setting quality of service parameters in the SS7-routed messages sent over the virtual bus; and
  - 10 (b) at least one second distributed gateway routing element including a first interface for receiving the SS7-routed messages from the first distributed gateway routing element and a second interface for SS7-routing the received messages to a second SS7 network element via an SS7 signaling link.
2. The distributed gateway of claim 1 wherein the first interfaces of the first and second distributed gateway routing elements include SS7 MTP layer 3 routing functions for routing SS7 messages based on  
20 SS7 point codes.
3. The distributed gateway of claim 1 wherein the first interfaces of the first and second distributed gateway routing elements are adapted to route messages based on circuit identification codes.
4. The distributed gateway of claim 1 wherein the first interfaces are  
25 adapted to screen the SS7 call signaling messages based on one or more SS7 message parameters.
5. The distributed gateway of claim 1 wherein the first interfaces of the distributed gateway routing elements are adapted to copy the SS7 call signaling messages and forward the copies to a predetermined  
30 network monitoring or accounting node.
6. The distributed gateway of claim 1 wherein the distributed gateway routing elements each include a triggerless number portability process

for identifying call signaling messages relating to calls to ported numbers and for overriding the SS7 routing functions for the call signaling messages related to calls directed to ported numbers.

- 5 7. The distributed gateway routing element of claim 1 wherein the second interfaces of the first and second distributed gateway routing elements include protocol translation processes for translating the protocol of the SS7-routed messages to and from the protocol of the virtual bus.
- 10 8. The distributed gateway of claim 1 wherein the second interfaces of the first and second distributed gateway routing elements include quality of service manager processes for setting the quality of service parameters in the SS7-routed messages to be transmitted over the virtual bus.
- 15 9. The distributed gateway of claim 1 wherein the first and second distributed gateway routing elements are co-located with the first and second SS7 network elements.
- 20 10. The distributed gateway of claim 9 wherein the first and second distributed gateway routing elements are co-located with service switching points (SSPs).
- 25 11. The distributed gateway of claim 9 wherein the first and second distributed gateway routing elements are co-located with service control points (SCPs).
- 30 12. The distributed gateway of claim 9 wherein the first distributed gateway routing element is co-located with a service switching point and the second distributed gateway routing element is co-located with a service control point (SCP).
13. The distributed gateway of claim 9 wherein at least one of the first and second distributed gateway routing elements is co-located with a signal transfer point (STP).
14. The distributed gateway of claim 9 wherein at least one of the first and second distributed gateway routing elements are co-located with a softswitch.



15. The distributed gateway of claim 9 wherein at least one of the distributed gateway routing elements is co-located with an application server.
- 5 16. The distributed gateway of claim 1 wherein at least one of the first and second distributed gateway routing elements are co-located with more than one SS7 network element.
17. The distributed gateway of claim 1 comprising a translation services module coupled to the first and second distributed gateway routing elements via the virtual bus for translating SS7-routed messages.
- 10 18. The distributed gateway of claim 17 wherein the translation services module is adapted to perform global title translation services for the SS7-routed messages.
19. The distributed gateway of claim 17 wherein the translation services module is adapted to perform directory number to Internet protocol address mapping for the SS7-routed messages.
- 15 20. The distributed gateway of claim 17 wherein the translation services module is adapted to perform number portability translation services for the SS7-routed messages.
21. The distributed gateway routing element of claim 17 wherein the distributed gateway routing elements and the translation services module share a single SS7 point code and function collectively as a signal transfer point.
- 20 22. The distributed gateway of claim 1 wherein the first and second distributed gateway routing elements each comprise a general purpose computer.
- 25 23. The distributed gateway of claim 1 comprising an operations, administration, and maintenance element coupled to the first and second distributed gateway routing elements for provisioning and maintaining databases on the first and second distributed gateway routing elements.
- 30 24. The distributed gateway of claim 23 wherein the operations, administration, and maintenance element is coupled to the first and

second distributed gateway routing elements via a simple network management protocol (SNMP) interface.

25. A distributed gateway comprising:

- 5 (a) a first distributed gateway routing element co-located with an SS7 service switching point for receiving call signaling messages from the service switching point via an SS7 signaling link, for determining quality of service parameters for the call signaling messages, for generating and adding a header to each of the call signaling messages, the header including the quality of service parameters, and for forwarding the call signaling messages over a virtual bus; and
- 10 (b) a second distributed gateway routing element co-located with a second service switching point for receiving the call signaling messages from the virtual bus, removing the headers, and for forwarding the call signaling messages to the second service switching point via an SS7 signaling link.
- 15

26. The distributed gateway of claim 25 comprising a third distributed gateway routing element coupled to the first and second distributed gateway routing elements via the virtual bus, the third distributed gateway routing element being co-located with an SS7 service control point for sending and receiving call signaling messages via the virtual bus with a specified quality of service.

20

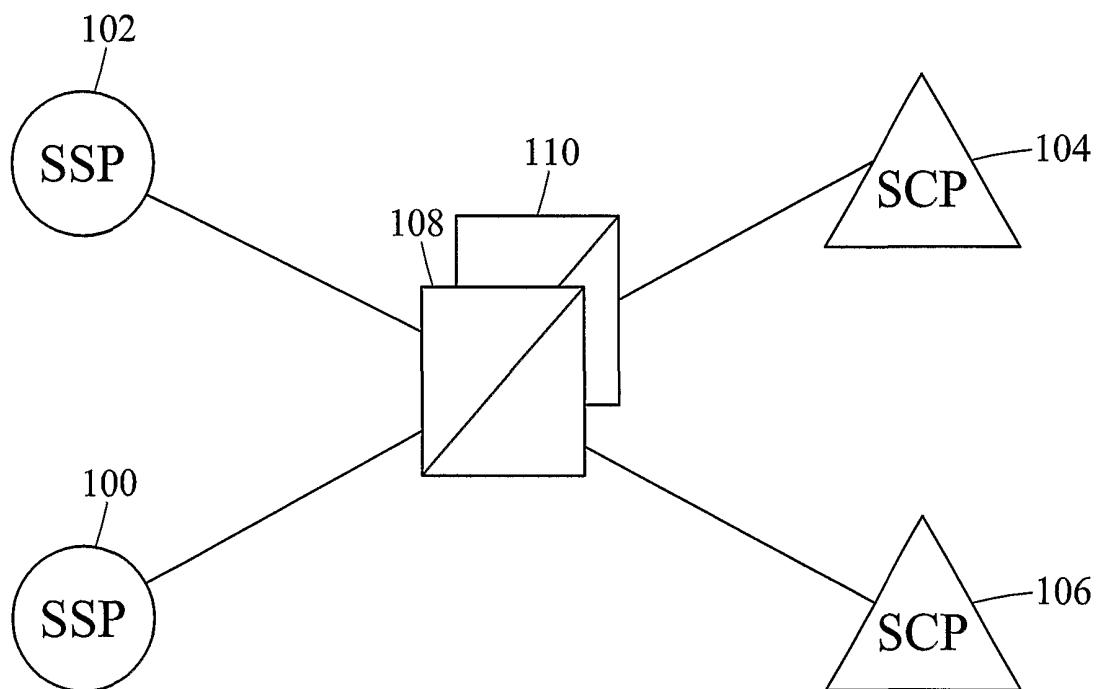
27. The distributed gateway of claim 25 comprising a translation services module coupled to the first and second distributed gateway routing elements via the virtual bus for performing SS7 translation operations on received call signaling messages and for forwarding the translated call signaling messages to one of the first and second distributed gateway routing elements via the virtual bus.

25

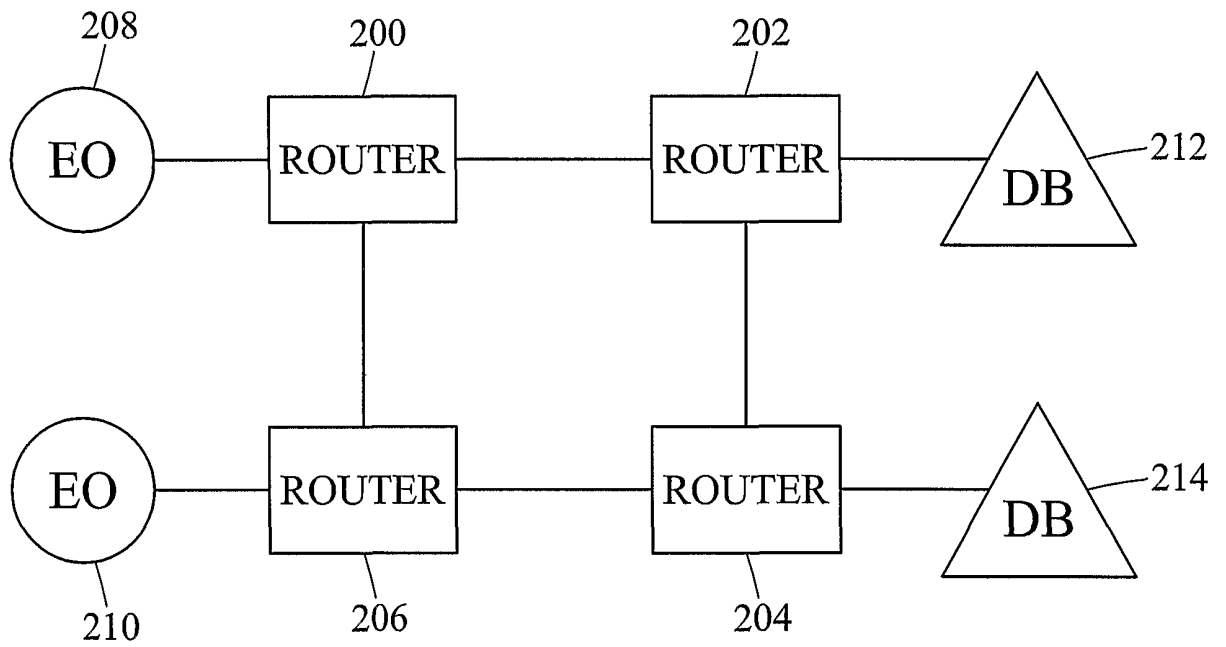
28. The distributed gateway of claim 27 wherein the translation services module is adapted to convert the call signaling messages between American National Standards Institute (ANSI) to International Telecommunications Union (ITU) message formats.

30

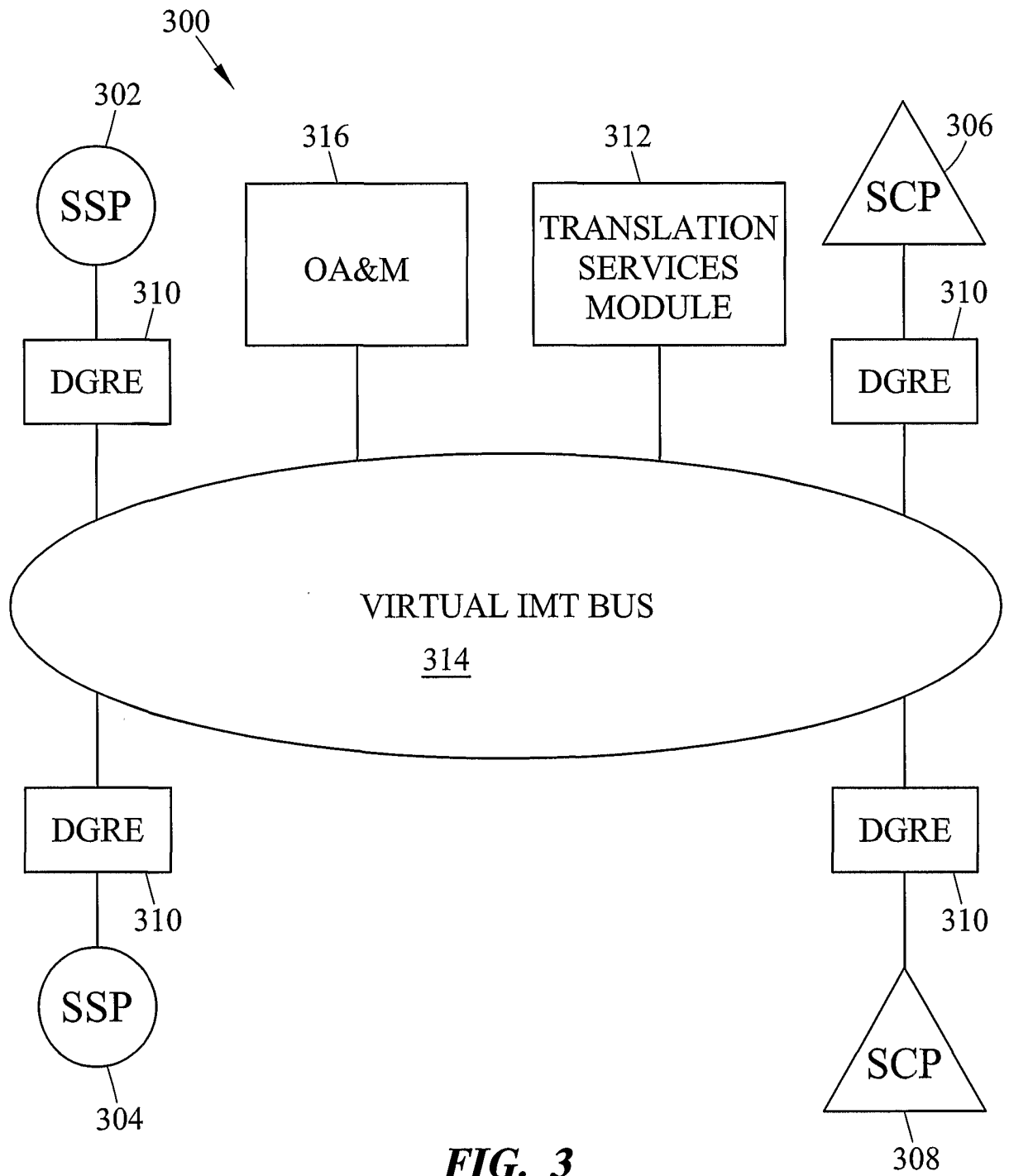
29. The distributed gateway of claim 25 comprising an operations, administration, and maintenance module coupled to the first and second distributed gateway routing elements via the virtual bus for provisioning and maintaining databases associated with the first and second distributed gateway routing elements.
- 5
30. A method for routing SS7 messages using a distributed gateway, the method comprising:
- (a) receiving an SS7 call signaling message from an SS7 network element via an SS7 signaling link;
  - 10 (b) performing SS7 routing operations on the SS7 call signaling message;
  - (c) determining quality of service parameters for the SS7 call signaling message;
  - (d) adding a virtual bus header to the SS7 call signaling message and setting the quality of service parameters in the virtual bus header; and
  - 15 (e) sending the call signaling message to a distributed gateway routing element associated with a destination SS7 network element via the virtual bus.
- 20 31. The method of claim 30 wherein setting quality of service parameters in the virtual bus header includes setting a parameter in a flow label field of an Internet protocol version 6 header.
32. The method of claim 30 wherein setting quality of service parameters in the virtual bus header includes writing a predetermined value into a type of service (TOS) field in an IP version 4 header.
- 25 33. The method of claim 30 wherein setting quality of service parameters in the virtual bus header includes adding a multiprotocol label switching (MPLS) header to the call signaling message.



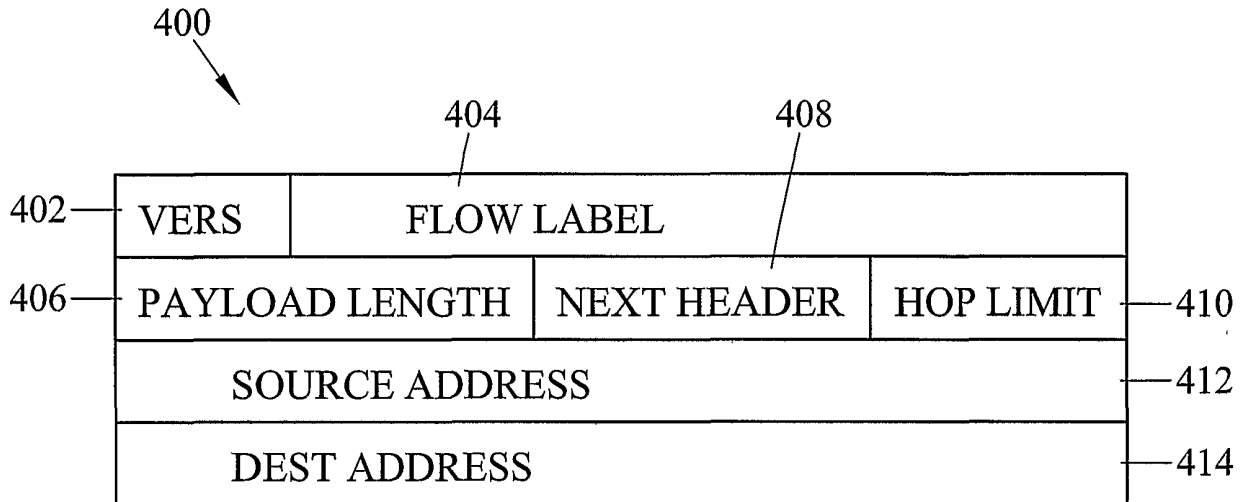
**FIG. 1**  
**(PRIOR ART)**



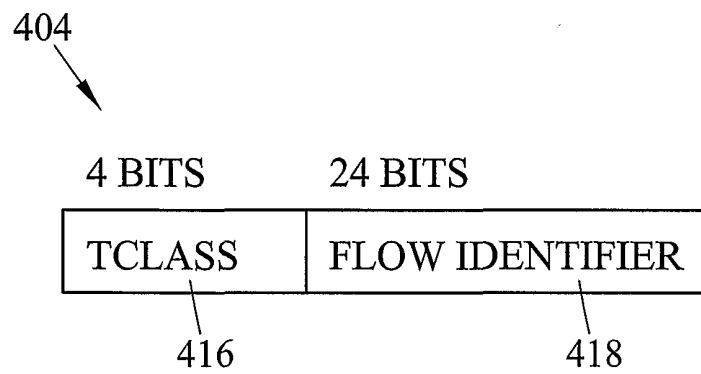
**FIG. 2**  
**(PRIOR ART)**



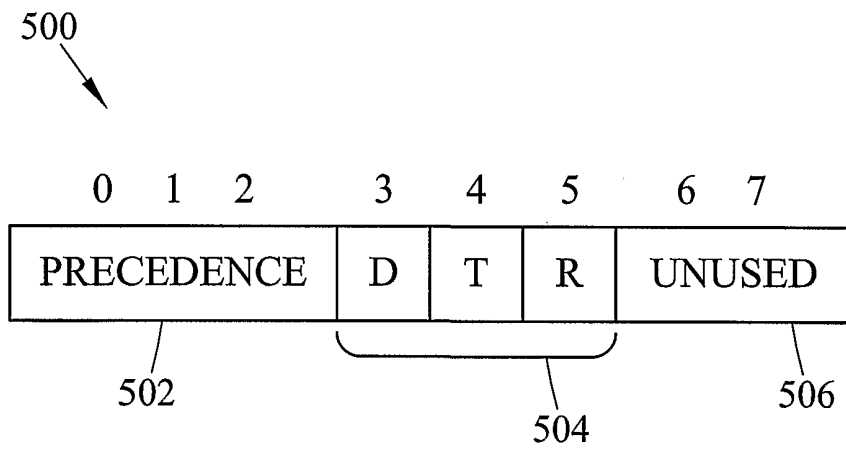
**FIG. 3**



**FIG. 4(A)**

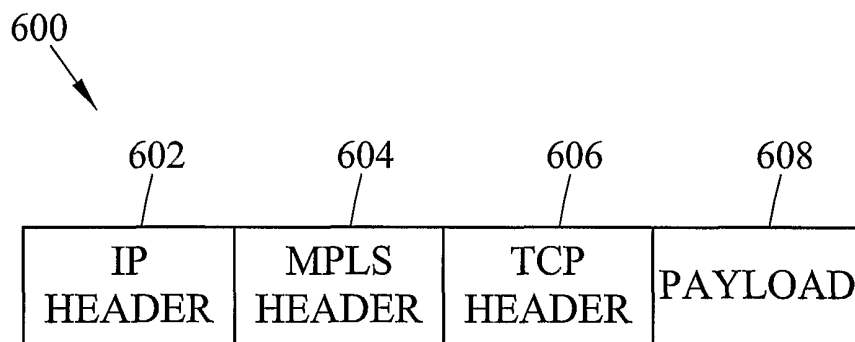


**FIG. 4(B)**

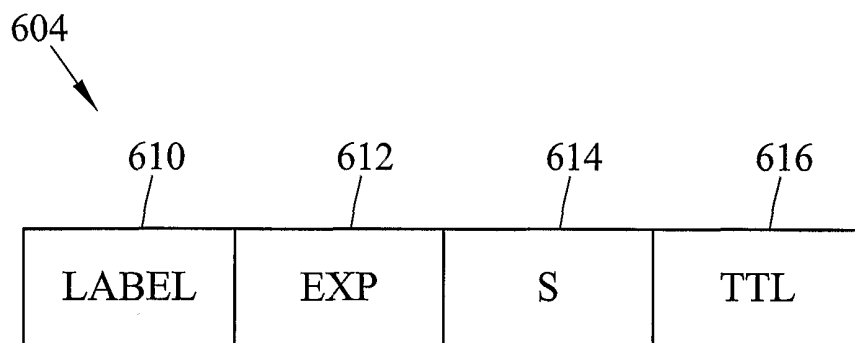


**FIG. 5**

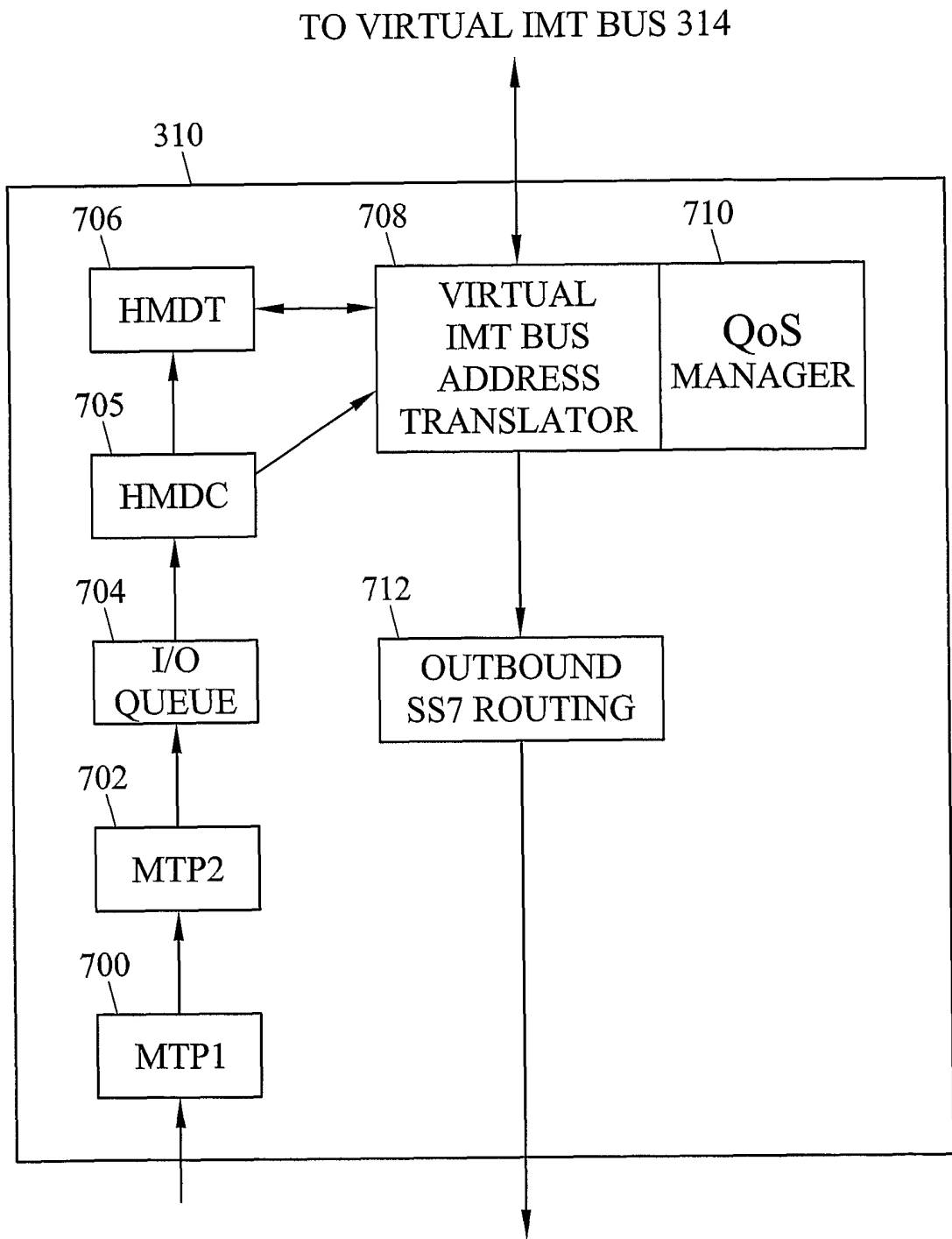




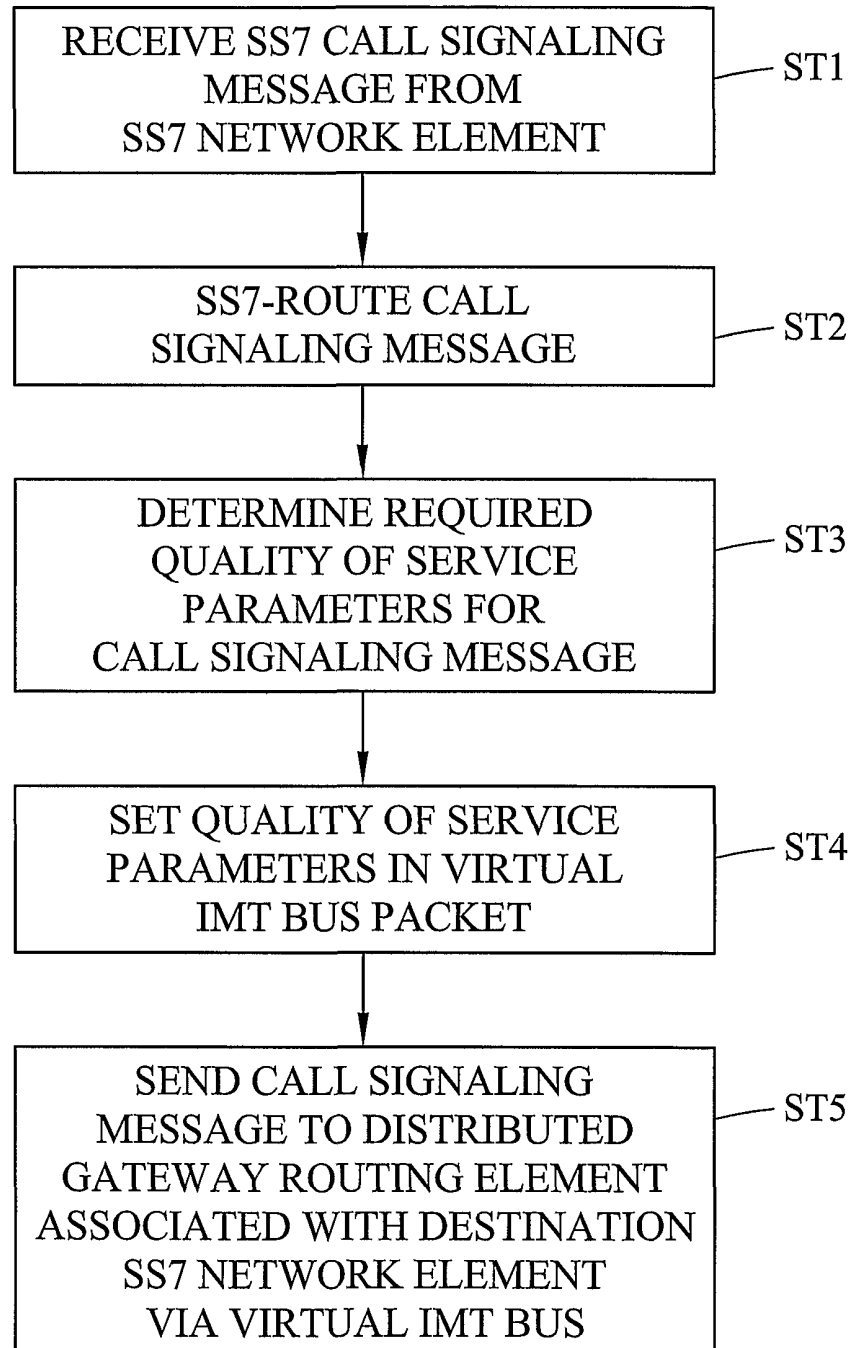
**FIG. 6(A)**

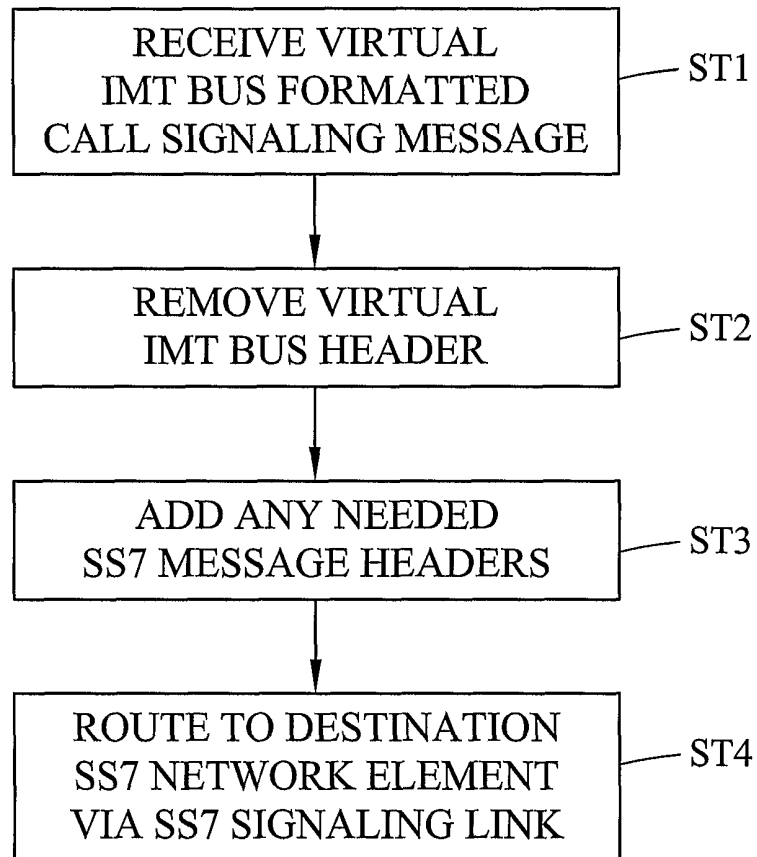


**FIG. 6(B)**



**FIG. 7**

**FIG. 8**

**FIG. 9**