

W. T. MOSHER.

Improvement in Bee-Hives.

No. 130,932.

Patented Aug. 27, 1872.

Fig. 1.

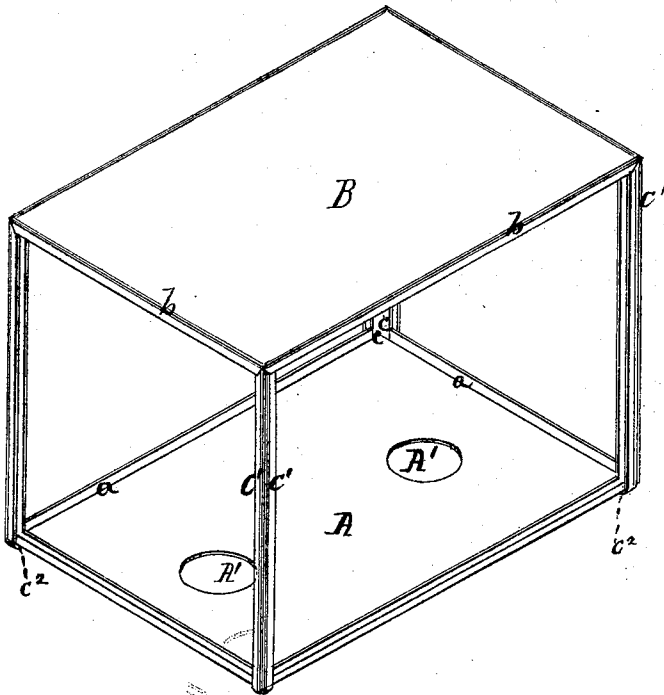
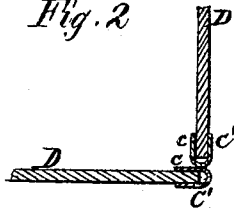

Fig. 2.



Witnesses.

Alex Mahon
Harry Saleman.

Inventor

Wm T. Mosher
by A. M. Smith
Attorney

UNITED STATES PATENT OFFICE.

WILLIAM T. MOSHER, OF POPLAR RIDGE, NEW YORK.

IMPROVEMENT IN BEE-HIVES.

Specification forming part of Letters Patent No. 130,932, dated August 27, 1872.

To all whom it may concern:

Be it known that I, WILLIAM T. MOSHER, of Poplar Ridge, county of Cayuga, State of New York, have invented certain new and useful Improvement in Bee-Hives, of which the following is a full, clear, and exact description, reference being had to the accompanying drawing making part of this specification, in which—

Figure 1 is a perspective view, and Fig. 2 is a horizontal section, showing the construction of the metallic frame.

My invention relates to the manufacture of honey-boxes adapted to be applied to the top of an ordinary bee-hive, its object being to produce a cheap durable box, one that will hold the honey in safe and convenient form for exhibition, sale, and use, and one which may be readily taken apart for the purpose of cleaning or repairing. To this end the invention consists in forming the top and bottom of the box of sheet metal, and connecting them at the corners by means of grooves or flanged ribs or posts for the reception of plates of glass to form the side of the box, the top, bottom, and corners being rigidly secured together, and forming, practically, a single piece.

In the drawing, A represents the bottom of the box, made, preferably, of sheet-tin, and provided with holes A A', which afford a passage for the bees. B is the top, also made of sheet-tin. These parts are connected by the flanged posts c c' c'' , shown in section in Fig. 2. These posts consists of two V-shaped sections, soldered or otherwise securely fastened to each other by their backs or closed sides, leaving the flanges or lips c c' of each part projecting at right angles from each other, and in planes parallel with the sides of the top and bottom, so as to receive and hold firmly the sides D of glass. The top of the box is a little larger than the bottom, overlapping the posts, and is provided with flanges upon each side to which the outer flanges c' of the posts are secured. The bottom has also flanges a upon each side, to which inner flanges c of the posts are attached. After the top and bottom are thus united I slip the glass plates D into the grooves between the flanges c c' , thus completing the box.

It will be readily understood from the above description that the upper edge of the glass is inclosed by the flange b , and rests directly against the top B, while bottom A is inclosed by the glass—that is, the glass is outside of the bottom. In order to retain the glass in position I bend the lower ends of flange c' inward, as at c'' , thus confining the plates against upward or downward motion between top B and these inturned ends. By merely bending these ends outward again the plates can be readily removed.

When the boxes after being filled with honey are removed for storage or transportation, they are turned upside down, when any drippings from the comb will be collected and retained in the lower part. It will be observed that the upper ends of the inner flanges c and the opposite ends of the outer flanges c' are left free.

I prefer this construction, as I can readily close them together or spread them apart, so that they shall fit accurately any thickness of glass, thus making the box tight enough to hold the honey securely; but I do not wish to be limited to this construction.

Wood or metal might be used for sides or panels D instead of glass, but I prefer to use the latter material, as it exposes the honey to view both during the process of making and when offered for sale; but I do not wish to be limited to the use of any particular material.

I am aware that honey-boxes have been made in which the various parts were united by means of strips of flexible metal which could be bent as desired, to release the sides or top and bottom; hence I do not wish to claim such construction, broadly. But this class of boxes are generally very frail from the fact that either the frame-work is held together only by the pliable metal or by slender posts of wood, and are not desirable because the metal has to be bent at a right angle to secure the parts, and then straightened to nearly a right line to release them, which operation soon breaks the strip and renders it worthless; whereas, in my box the top, bottom, and posts are rigidly and securely fastened together, and the posts being made of two arched sections placed back to back,

are very strong. Under ordinary circumstances the glass plates may be held in place by the friction of the flanges of the posts clasping each side of said plate; but yet under ordinary circumstances I prefer to bend the upper ends of the outer flanges inward a little, as set forth above; but so little bend is made that it might be repeated almost indefinitely without breaking the metal, and even though it should be broken the box is not seriously impaired thereby.

Having now described my invention, what

I claim as new, and desire to secure by Letters Patent, is—

The herein-described honey-box, consisting of the metal bottom A, overlapping top B, the posts *cc'*, each composed of the U-shaped sections united at their back, and the sliding glass plates D, these parts being constructed and combined substantially as set forth.

WILLIAM T. MOSHER.

Witnesses:

SIDNEY MOSHER,
T. S. DOWNING.