

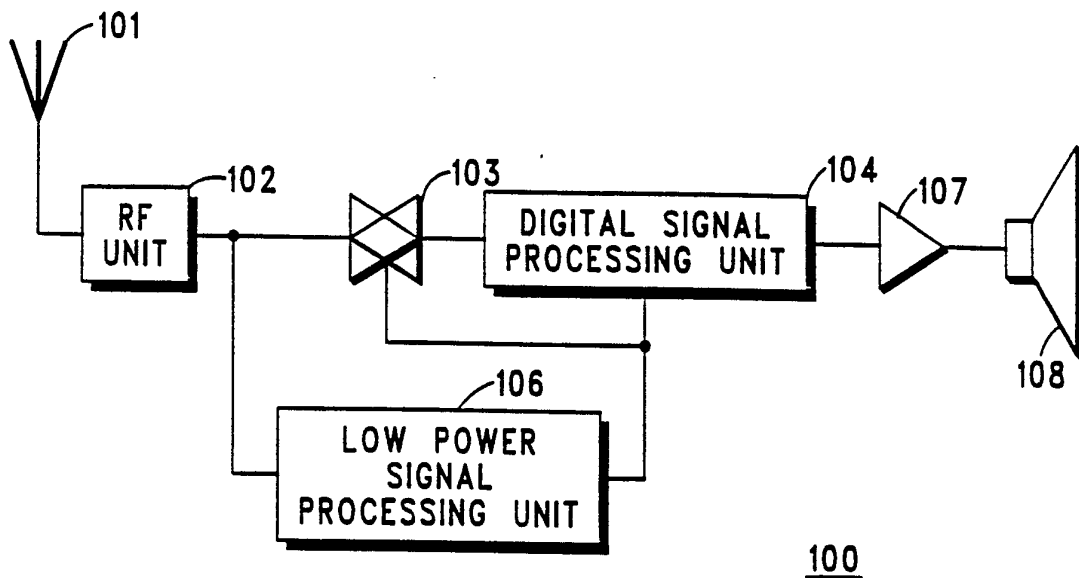

INTERNATIONAL APPLICATION PUBLISHED UNDER THE PATENT COOPERATION TREATY (PCT)

<p>(51) International Patent Classification <sup>5</sup> : <b>H04B 1/16</b></p>	<p><b>A1</b></p>	<p>(11) International Publication Number: <b>WO 90/11652</b> (43) International Publication Date: 4 October 1990 (04.10.90)</p>
<p>(21) International Application Number: PCT/US90/01336 (22) International Filing Date: 13 March 1990 (13.03.90) (30) Priority data: 325,603 20 March 1989 (20.03.89) US (71) Applicant: MOTOROLA, INC. [US/US]; 1303 East Algonquin Road, Schaumburg, IL 60196 (US). (72) Inventor: SOBTI, Arun ; 2057 Sherwood Place, Wheaton, IL 60187 (US). (74) Agents: PARMELEE, Steven, G. et al.; Motorola, Inc., Intellectual Property Dept., 1303 East Algonquin Road, Schaumburg, IL 60196 (US).</p>		<p>(81) Designated States: AT (European patent), BE (European patent), CA, CH (European patent), DE (European patent), DK (European patent), ES (European patent), FR (European patent), GB (European patent), IT (European patent), JP, KR, LU (European patent), NL (European patent), SE (European patent).  +  <b>Published</b> <i>With international search report.</i></p>

(54) Title: DSP BASED RADIO WITH DIMINISHED POWER REQUIREMENTS



(57) Abstract

A radio (100) having two signal processing paths, one including a digital signal processor (104) that consumes a relatively large amount of power and one including a signal processor (106) that consumes a relatively small amount of power. The low power processor (106) operates to monitor for broadcast signals of interest. Upon detecting such a signal, the low power processor (106) enables the digital signal processor (104) to facilitate proper signal processing.

## DESIGNATIONS OF "DE"

Until further notice, any designation of "DE" in any international application whose international filing date is prior to October 3, 1990, shall have effect in the territory of the Federal Republic of Germany with the exception of the territory of the former German Democratic Republic.

### *FOR THE PURPOSES OF INFORMATION ONLY*

Codes used to identify States party to the PCT on the front pages of pamphlets publishing international applications under the PCT.

AT	Austria	ES	Spain	MG	Madagascar
AU	Australia	FI	Finland	ML	Mali
BB	Barbados	FR	France	MR	Mauritania
BE	Belgium	GA	Gabon	MW	Malawi
BF	Burkina Faso	GB	United Kingdom	NL	Netherlands
BG	Bulgaria	HU	Hungary	NO	Norway
BJ	Benin	IT	Italy	RO	Romania
BR	Brazil	JP	Japan	SD	Sudan
CA	Canada	KP	Democratic People's Republic of Korea	SE	Sweden
CF	Central African Republic	KR	Republic of Korea	SN	Senegal
CG	Congo	LI	Liechtenstein	SU	Soviet Union
CH	Switzerland	LK	Sri Lanka	TD	Chad
CM	Cameroon	LJ	Luxembourg	TG	Togo
DE	Germany, Federal Republic of	LU	Luxembourg	US	United States of America
DK	Denmark	MC	Monaco		

5

## DSP BASED RADIO WITH DIMINISHED POWER REQUIREMENTS

10

### Technical Field

This invention relates generally to radios, and more particularly to radios that include a digital signal processor.

15

### Background Art

Radios generally function to receive broadcast signals. Usually, the user of a radio will not be interested in all of the signals that are broadcast on a communication resource (such as a particular frequency or a particular TDM time slot). Since many broadcast signals of interest include an identifying signal or other identifying indicia, many radios include a signal processor that examines the received broadcast signal to determine the presence of the identifying signal. If present, the radio can be further enabled to render the broadcast signal audible, visible, or otherwise as appropriate for that particular broadcast signal.

For example, some radios remain squelched unless a carrier can be sensed on a particular monitored communication resource. Other broadcast signals include special identifying signals, such as tone signals or subaudible digital signals, that the radio can recognize and respond to. Yet other signals of interest can be

30

prefaced with a specific identifying preamble, such as an ID for the intended radio.

In order to expand the capabilities and flexibility of radios, digitizers and digital signal processors (DSPs) have been used.

5 These processors typically receive digitized received signals. Further processing of the signal, equivalent to IF and discriminator processing, then occurs in the DSP in a digital manner. The resultant signal can then be converted into analog form and processed further as appropriate. For example, the resultant signal may be rendered  
10 audible in the case of a voice transmission.

DSPs, however, consume a significant amount of power when operating. This becomes a particular problem when seeking to use a DSP in a portable radio with limited power resources. DSP power consumption becomes of particular concern when the DSP operates  
15 both in the presence and absence of a broadcast signal of interest. Typically, the DSP must operate even in the absence of a broadcast signal of interest because the DSP itself aids in detecting the presence of a broadcast signal of interest. Unless the broadcast signals of interest occur at known times, the DSP must remain active  
20 in order to detect the signal when it occurs.

#### Summary of the Invention:

This invention allows a DSP to be used in a radio while  
25 avoiding the necessity of continuous DSP operation.

The invention includes generally two signal processing units; the first includes the DSP and the second includes a processing unit having lesser capabilities and smaller power requirements. The DSP based signal processing unit functions to fully process broadcast  
30 signals of interest. The low power processing unit functions to detect the presence of a broadcast signal of interest, and upon detecting

such a signal, the low power processing unit enables the DSP based processing unit to begin functioning.

Through use of this invention, the high power requirements of the DSP based processing unit are necessitated only when a  
5 broadcast signal of interest exists. Otherwise, a lower power broadcast signal of interest detection mechanism monitors the communication resource.

Brief Description of the Drawings:

10

Fig. 1 comprises a block diagram depiction of the invention;

Fig. 2 comprises a block diagram depiction of the low power signal processing unit.

15 Best Mode for Carrying out the Invention:

Referring to Fig. 1, a radio (100) includes generally an antenna (101) for receiving broadcast signals and an RF unit (102) for appropriately processing the received broadcast signals. The  
20 received signals are then passed to a low power signal processing unit (106) and also through an appropriate gate (103) to a digital signal processing unit (104) (the latter typically including a DSP such as the Motorola 56000 and a microprocessor to control the DSP). The output of the digital signal processing unit (104) then couples to  
25 an appropriate amplifier (107) and speaker (108) or other output devices as appropriate to the type of message received.

With reference to Fig. 2, the low power signal processing unit (106) includes an appropriate IF unit (201) for receiving the output signal from the RF unit (102), a discriminator (202) for processing the  
30 IF unit (201) output to aid in recovering the original modulating signal, and a processing unit (203) for examining the recovered signal and determining whether an appropriate identifying signal is

present. The processing unit (203) could be any relatively simple and low power device, such as a Motorola MC6303 processor.

Upon detecting the presence of a broadcast signal of interest, the processing unit (203) of the low power signal processing unit provides a signal to the gate (103), thereby allowing the RF signal to be provided to the digital signal processing unit (104). At the same time, the processing unit (203) provides an enable signal to the digital signal processing unit (104) to activate that unit and cause it to begin processing the incoming signal.

So configured, the digital signal processing unit will operate only when a broadcast signal of interest can be detected. Otherwise, the low power signal processing unit will monitor the received broadcast signals and control the activation of the digital signal processing unit as a function of the presence and absence of a broadcast signal of interest.

I claim:

- 1) A radio having signal receiving means for receiving broadcast signals, and digital signal processing means that requires a first amount of power to operate for converting the received broadcast signal into a first signal, characterized by:
- 5
- A) switch means:
- responsive to a control signal; and
- being operably coupled between the signal receiving
- 10 means and the digital signal processing means;
- for selectively allowing the broadcast signal as received by the signal receiving means to be provided to the digital signal processing means;
- 15
- B) low power signal processing means:
- operably coupled to the signal receiving means; and
- requiring a second amount of power, said second amount of power being less than the first amount of power;
- for detecting a broadcast signal of interest and providing a
- 20 control signal to the switch means in response thereto.

- 2) A radio having signal receiving means for receiving broadcast signals, and digital signal processing means that requires a first amount of power to operate for converting the received broadcast signal into a first signal, characterized by low power signal processing means:
- 5 operably coupled to the signal receiving means; and  
requiring a second amount of power, said second amount of power being less than the first amount of power;  
for detecting a broadcast signal of interest and
- 10 providing a control signal to the digital signal processing means to substantially control power consumption of the digital signal processing means.



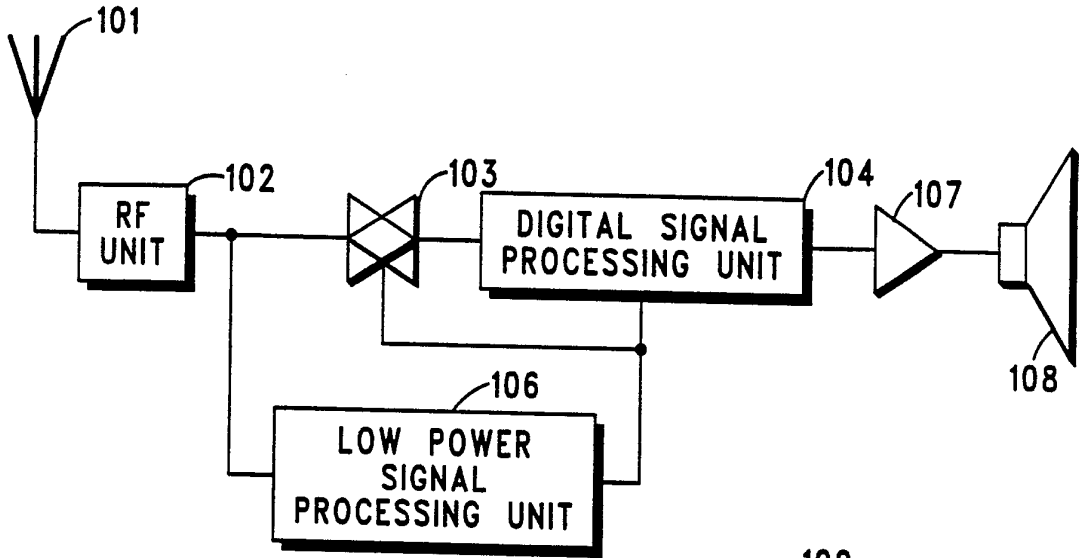

100  
**FIG. 1**

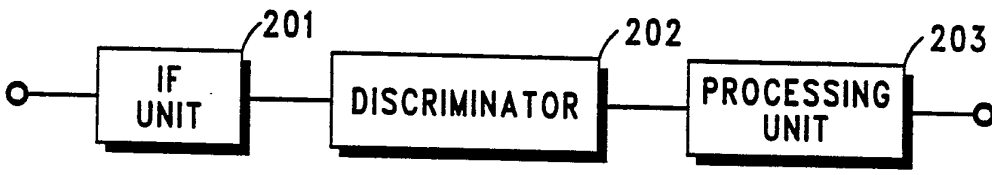

106  
**FIG. 2**

# INTERNATIONAL SEARCH REPORT

International Application No.

PCT/US90/01336

**I. CLASSIFICATION OF SUBJECT MATTER** (if several classification symbols apply, indicate all) <sup>6</sup>

According to International Patent Classification (IPC) or to both National Classification and IPC

IPC (5) : H04B 1/16

U.S. Cl : 455/343

**II. FIELDS SEARCHED**

Minimum Documentation Searched <sup>7</sup>

Classification System

Classification Symbols

U.S.

455/127,214,229,343,335

Documentation Searched other than Minimum Documentation  
to the Extent that such Documents are Included in the Fields Searched <sup>8</sup>

**III. DOCUMENTS CONSIDERED TO BE RELEVANT <sup>9</sup>**

Category <sup>*</sup>	Citation of Document, <sup>11</sup> with indication, where appropriate, of the relevant passages <sup>12</sup>	Relevant to Claim No. <sup>13</sup>
Y	US,A 4,419,765 (WYCOFF) 06 December 1983 See Figure 1 and Column 5, Lines 13-26.	1-2

<sup>\*</sup> Special categories of cited documents: <sup>10</sup>

"A" document defining the general state of the art which is not considered to be of particular relevance

"E" earlier document but published on or after the international filing date

"L" document which may throw doubts on priority claim(s) or which is cited to establish the publication date of another citation or other special reason (as specified)

"O" document referring to an oral disclosure, use, exhibition or other means

"P" document published prior to the international filing date but later than the priority date claimed

"T" later document published after the international filing date or priority date and not in conflict with the application but cited to understand the principle or theory underlying the invention

"X" document of particular relevance; the claimed invention cannot be considered novel or cannot be considered to involve an inventive step

"Y" document of particular relevance; the claimed invention cannot be considered to involve an inventive step when the document is combined with one or more other such documents, such combination being obvious to a person skilled in the art.

"&" document member of the same patent family

**IV. CERTIFICATION**

Date of the Actual Completion of the International Search

25 May 1990

Date of Mailing of this International Search Report

12 JUL 1990

International Searching Authority

ISA/US

Signature of Authorized Officer

*Edward Urban*  
Edward Urban