

W. WILSON.
OIL BURNER.

APPLICATION FILED AUG. 21, 1912.

1,060,149.

Patented Apr. 29, 1913.

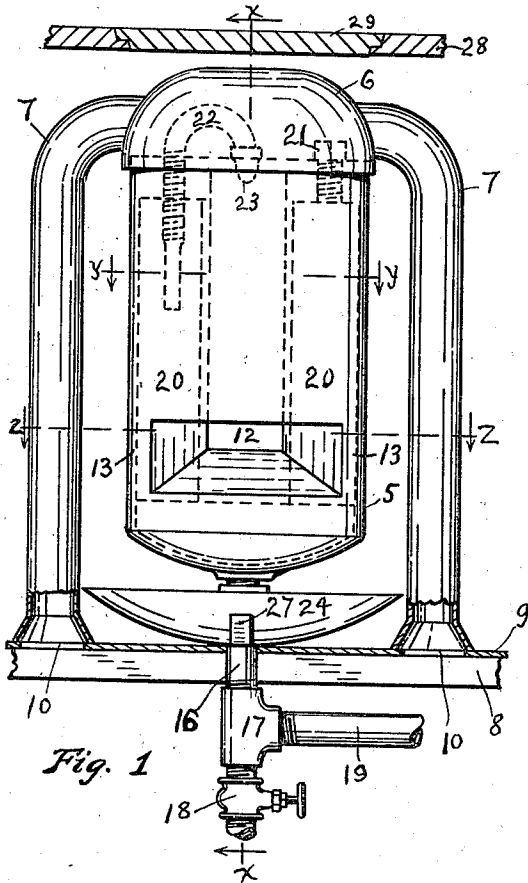

Fig. 1

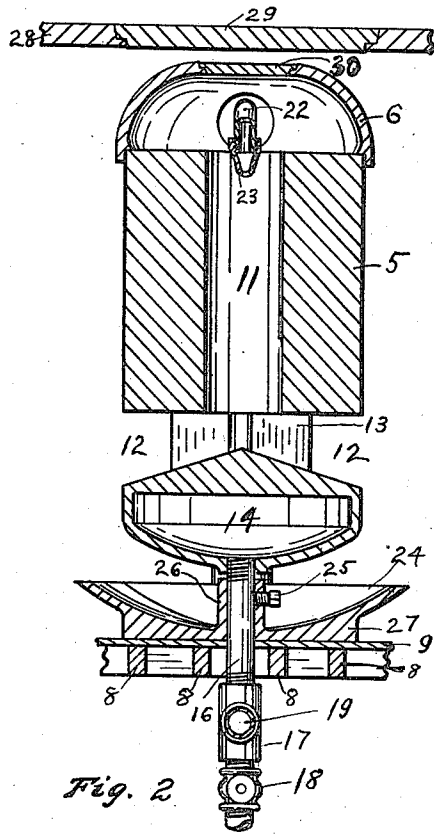

Fig. 2

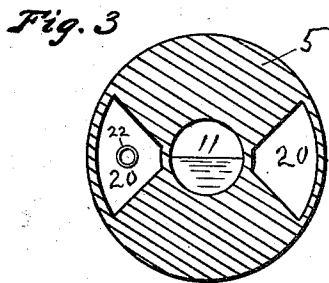

Fig. 3

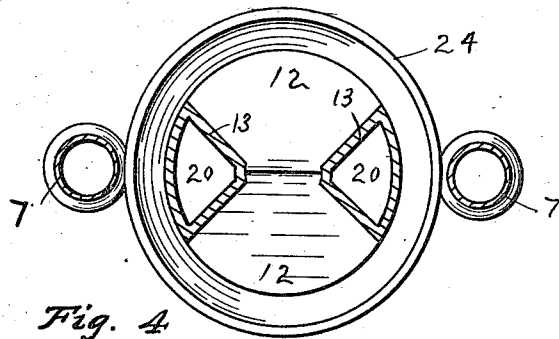

Fig. 4

WITNESSES:

J. G. Matheny
Geo Blair

INVENTOR

Wallace Wilson

BY

C. D. Haskins
ATTORNEY

UNITED STATES PATENT OFFICE

WALLACE WILSON, OF SEATTLE, WASHINGTON.

OIL-BURNER.

1,060,149.

Specification of Letters Patent.

Patented Apr. 29, 1913.

Application filed August 21, 1912. Serial No. 716,229.

To all whom it may concern:

Be it known that I, WALLACE WILSON, citizen of the United States, residing at Seattle, in the county of King and State of Washington, have invented a certain new and useful Improvement in Oil-Burners, of which the following is a specification.

My invention relates to improvements in burners adapted to burn fluid fuel such as crude oil, kerosene oil, gasolene, coal gas and the like, but more particularly my invention relates to such burners that may be employed advantageously in connection with stoves adapted for heating or cooking, and the object of my invention is to provide a burner that shall be simple in its construction, easily cleaned, comparatively inexpensive to manufacture, reliable and efficient in its operation and that shall be adapted to utilize for its fuel any one of a number of different mineral oil products and gases, and a further object of my invention is to provide a burner that readily may be attached to different kinds of stoves that are in general use. I attain these objects by devices illustrated in the accompanying drawings, wherein—

Figure 1 illustrates a burner embodying my invention by a view in side elevation in which broken lines indicate the form of some internal parts, fragments of a stove with which it is associated being indicated by a view in vertical-section showing one fragment and a view in side elevation showing another fragment, Fig. 2 is a view of the same in vertical-section on broken line $x-x$ of Fig. 1, Fig. 3 is a plan view showing a part of the same in longitudinal-section on broken line $y-y$ of Fig. 1 and Fig. 4 is a plan view of my invention in longitudinal-section on broken line $z-z$ of Fig. 1.

Like reference numerals indicate like parts throughout the drawing.

Referring to Fig. 1 of the drawing, 5 illustrates the body of a burner, preferably of cast iron, of cylindrical shape whose bottom end is convex in form and whose top end is flat and adapted to engage with and support a shell like hood 6, from each of opposite sides of which extends an air pipe or flue 7 which curves downwardly in a line parallel with the body 5 of the burner to rest its flaring open end on the bars of a grate 8 between which grate 8 and the flaring ends of the said flues 7 is disposed a sheet 9 of asbestos provided with holes 10,

which register with the open flaring ends of said flues 7, whereby no air may pass upwardly through the grate 8 into the fire box of the stove but whereby air may pass from the space beneath the grate 8 through the holes 10 in the sheet 9 and into and through the flues 7 thence into the space within the hood 6. Extending from the space within the hood 6 downwardly in the body 5 is a passageway 11 leading into an opening 12 which extends from one side of the lower portion of the body 5 to the other side thereof whereby segmental portions 13 are left to unite the lower convex portion of the body 5 with the upper cylindrical portion of said body 5. The bottom surface of the opening 12 through the body 5 is formed to decline from the center to each of the outer sides of the body 5 as shown in Figs. 1 and 2 whereby air and products of combustion may impinge on the apex of the angle formed by said declining surfaces to split and deflect such air and products of combustion and thereby direct one half of such air and products of combustion to emerge from each of the sides of the opening 12. One function of such angular form of the surface of the bottom of the opening 12 is to deaden the roaring noise due to combustion of the fuel. By experiment I have found when such surface is flat the roaring noise is much greater in degree than when such surface is of the angular form illustrated in Figs. 1 and 2.

Within the lower convex portion of the body 5 is a chamber 14, shown in cross-section in Fig. 2 and indicated by broken lines in Fig. 1, into which leads a fuel feed pipe 16 to which is connected a T 17 which is provided on its lower end with a valve 18 through which accumulated sediment in the chamber 14 may be permitted to discharge. Extending from the side opening of the T 17 is a fuel supply pipe 19 which is indicated as broken off and which supply pipe 19 may be connected in an obvious manner with a source of fuel supply not shown. Extending upwardly from the chamber 14 through each of segmental portions 13, as indicated by broken lines in Fig. 1, are passages 20 which lead to and out of the top of the body 5. One of these passages 20 is normally closed by a screw 21 in the top of the body 5 while the other of these passages 20 terminates at the top of the body 5 with a screw-threaded hole into which one end of

a curved pipe 22 is screwed firmly, the other end of said curved pipe 21 turning downwardly and terminating in a burner tip 23 at the center of the top of the passageway 11, as indicated by broken lines in Fig. 1. Thus, fluid fuel may enter the feed pipe 16 from the supply pipe 19 to flow upwardly into the chamber 14 to fill such chamber 14 and thence to rise in one of the passages 20 and from thence flow into the curved pipe 22 and out of its tip 23 to fall downwardly onto the apex of the declining surfaces of the bottom of the opening 12 and therefrom drip into a priming pan 24 which is fastened by a screw 25 to the pipe 16 which pipe 16 extends through a hub 26 disposed in the center of and integral with said priming pan 24, which priming pan 24 is provided with a web 27 on its bottom which extends crosswise the bars of the grate 8 to support the whole structure from tipping sidewise in the fire box of a stove while the structure is prevented from tipping in a direction endwise with a fire box by the flues 7.

When the priming pan 24 has accumulated sufficient fuel the supply of fuel through the pipe 19 may be intercepted and thereupon the fuel in the priming pan 24 may be ignited to burn to heat the body 5 and the fuel within the chamber 14 to such high degree as to convert such fuel into the form of gas which may then flow downwardly from the burner tip 23 through the passageway 11 thence out each of the openings 12 to be ignited by the flame produced by the burning fuel in the priming pan 24 and when the structure is sufficiently heated the supply of fuel through the pipe 19 may be gaged to suit proper conditions of combustion.

Air for combustion passes from beneath the grate 8 upwardly through holes 10 in the asbestos sheet 9 thence through the flues 7 to the space within the hood 6 thence downwardly into the passageway 11 where it will mix with fuel to burn, the products of combustion and flame passing outwardly through the openings 12 into the fire box of the stove to escape through a suitable smoke pipe not shown.

I have shown by fragmentary view the top 28 of a stove provided with a removable cover 29 which cover 29 may be removed to give access to the structure within, and in the top of the hood 6 I have provided a small removable cover 30 to give access to the burner tip 23 in case such burner tip 23 may require cleaning or changing. Preferably the stove cover 29 and hole may be made much larger whereby the burner may be introduced into the fire box through the hole in the top of a stove to rest on the

grate 8, whereupon may be made the pipe connections beneath the grate.

Obviously minor modifications in the form of parts of my invention may be made without departing from the spirit thereof.

What I claim is:

1. In a burner of the class described, the combination with a burner body provided with an air passageway extending diametrically therethrough at a point near its lower end portion, and with a concentrically disposed flue extending downwardly from the top of said body to terminate within said passageway, and further provided with a chamber disposed within the lower end portion of said body, said chamber being provided with an inlet passageway through its bottom for fluid fuel and with outlet passageways extending upwardly to and out of the top of said body, of a suitably controlled fuel supply pipe connected with the inlet passageway of said chamber, a priming-pan suitably disposed beneath said burner body, a pipe connected with and extending from one of said outlet passageways at the top of said burner body to terminate at the upper entrance of said downwardly extending flue and there provided with a burner tip adapted to emit fluid fuel in a downward direction into said flue, a hood covering said burner body and disposed to afford air space between its walls and said burner body, and intake air pipes connected with said hood and adapted to conduct air for combustion to the space therewithin to flow thence to and downwardly through said flue.

2. In a burner of the class described, a burner body that is provided with a chamber in its lower end portion, above which chamber and adjacent thereto is a passageway extending transversely through said burner body, and further provided with a concentrically disposed flue communicating with and extending upwardly from said transverse passageway to and out of the top of said burner body, an inlet passageway adapted to conduct fluid fuel into said chamber, an outlet passageway leading from said chamber upwardly to and out of the top of said burner body, in combination with a pipe leading from said outlet passageway and disposed to conduct fluid fuel to a desired point of combustion within said concentrically disposed flue.

In witness whereof, I, hereunto subscribe my name this 25th day of July A. D. 1912.

WALLACE WILSON.

Witnesses:

FRANK WARREN,
ANNA HASKINS.