

J. KOHKE.
 DUPLEX HORN SEAM CLOSING MECHANISM.
 APPLICATION FILED MAY 18, 1908.

978,308.
 Fig. 1

Patented Dec. 13, 1910.
 Fig. 2 2 SHEETS-SHEET 1.

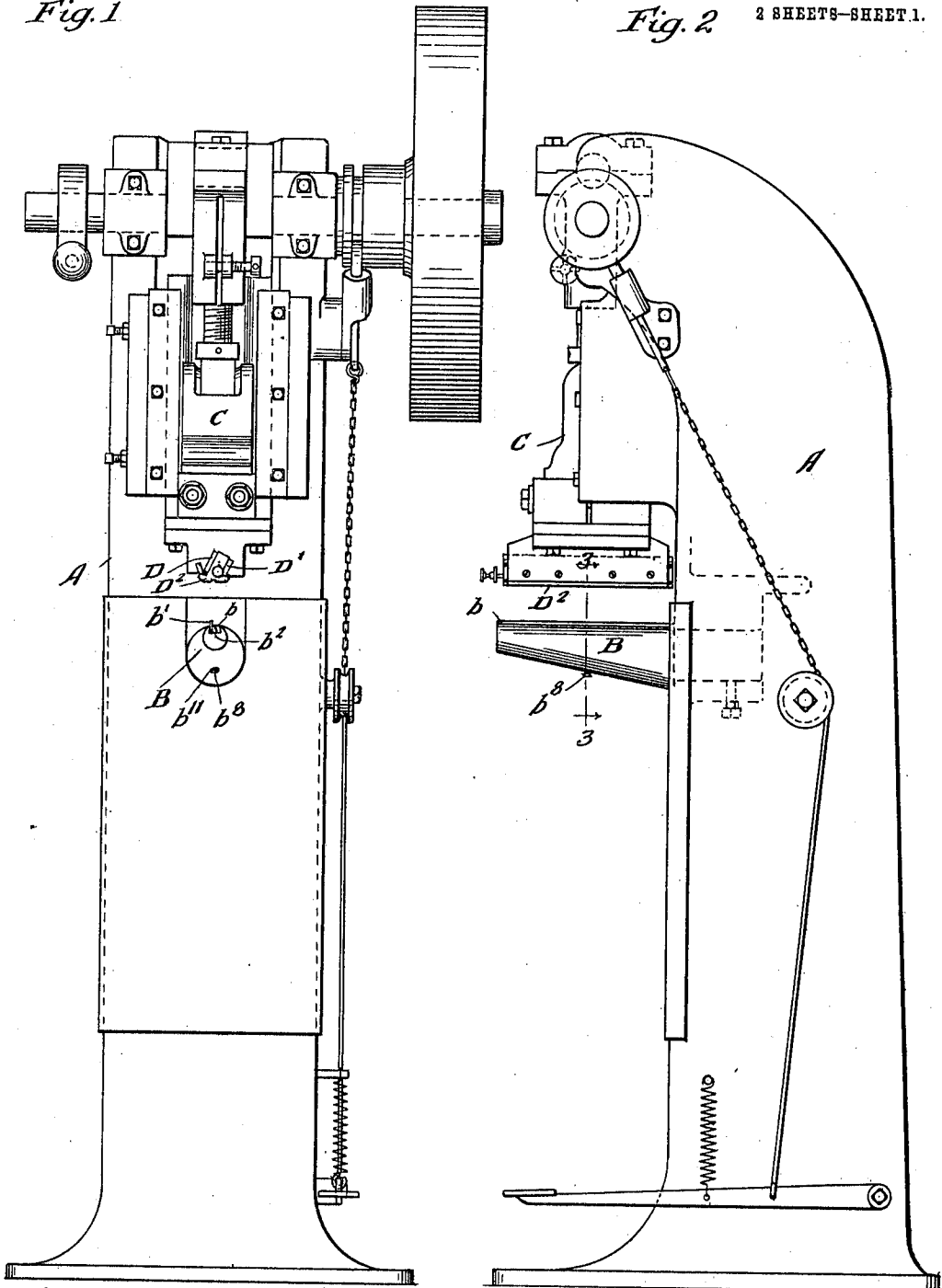

Witnesses:

Wm. Geiger
A. W. Munday

Inventor:
 John Kohke

By Munday, Everts, Adcock & Clarke.

Attorneys

UNITED STATES PATENT OFFICE.

JOHN KOHKE, OF ATLANTA, GEORGIA, ASSIGNOR TO AMERICAN CAN COMPANY, OF NEW YORK, N. Y., A CORPORATION OF NEW JERSEY.

DUPLEX-HORN SEAM-CLOSING MECHANISM.

978,308.

Specification of Letters Patent. **Patented Dec. 13, 1910.**

Application filed May 18, 1908. Serial No. 433,339.

To all whom it may concern:

Be it known that I, JOHN KOHKE, a citizen of the United States, residing in Atlanta, in the county of Fulton and State of Georgia, have invented a new and useful Improvement in Duplex-Horn Seam-Closing Mechanism, of which the following is a specification.

My invention relates to duplex horn seam closing devices.

The object of my invention is to provide a duplex horn seam closing device by means of which lock side seams upon the bodies of sheet metal pails or vessels may be conveniently formed either upon the inside or outside of the vessel.

My invention consists in connection with the horn, bumper and edge folding dies, of a fixed gage secured to the horn, a movable spring supported gage and an intermediate gage having a movable or adjustable fixed support for use in forming a lock seam on the outside of the can body, and which is adapted to be released or withdrawn so that this intermediate gage may move with the spring supported gage when it is desired to do inside grooving or form the lock seam upon the inside of the vessel.

My invention further consists in the novel construction of parts and devices, and in the novel combinations of parts and devices herein shown and described.

In the accompanying drawing forming a part of this specification, Figure 1 is a front elevation of the duplex horn edging and seam closing machine embodying my invention. Fig. 2 is a side elevation. Fig. 3 is a vertical cross section on line 3—3 of Fig. 2 and Fig. 4 is a vertical longitudinal section on line 4—4 of Fig. 3. Fig. 5 is a similar view to Fig. 3 showing method of forming inside seam.

In the drawing, A represents the frame of the machine.

B is the duplex grooving horn.

C is the reciprocating slide, D D¹ the edge folding dies and D² the seam closing die.

The duplex grooving horn B is provided with a fixed gage *b*, a yielding or movable spring supported gage *b*¹ and intermediate combined yielding or spring supported and fixed or stationary supported gage for use according as it is desired to form the groove for the lock seam upon the inside or upon the outside of the vessel. The fixed gage *b*

is removably secured to the horn by set screws *b*³. The movable spring supported gage *b*¹ is preferably supported upon four coiled springs *b*⁴, and it is provided with a stop shoulder *b*⁵ to engage a corresponding stop shoulder *b*⁶ on the horn B. The combined movable or fixed intermediate gage *b*² is preferably yielding supported upon four coiled springs *b*⁷ when it is desired to do inside grooving or form the lock seam upon the inside of the vessel, and it is withdrawn or let down as a fixed gage when it is desired to do outside grooving or form the lock seam upon the outside of the vessel by means of a holding down pin or rod *b*⁸ connected therewith by screw threads *b*⁹, and which holding down rod is furnished with a threaded nut *b*¹⁰ which fits in a socket *b*¹¹ in the horn B. The nut *b*¹⁰ is furnished with slots *b*¹² to receive a socket spanner wrench F for unscrewing the nut *b*¹⁰.

In operation, to do outside grooving and form the lock side seam *x* of the can body X upon the outside of the body, the nut *b*¹⁰ is turned so as to cause the holding down pin or rod *b*⁸ to hold the combined fixed and movable gage *b*² withdrawn and in fixed position on the horn B. To do inside grooving and form the lock side seam *x*¹ upon the outside of the can body, the nut *b*¹⁰ is unscrewed, thus leaving the intermediate gage *b*² free to move with the movable gage *b*¹ and to act as a yielding gage.

The seam closing die D² is provided on its under face with a groove *d* for receiving the lock seam of the body X when it is formed on the outside; and the fixed gage *b* is provided with a groove or channel *b*¹⁵ on its upper face to receive the lock seam of the can body when it is formed upon the inside of the can body.

I claim:—

1. In a duplex horn edging and seam closing machine, the combination with the horn and edge folding and seam closing dies having a groove on the under face to receive a lock seam when formed on the outside, of a fixed gage having a groove on its upper face to receive the lock seam when formed on the inside, a movable spring supported gage and an intermediate gage adapted to act either as a movable or as a fixed gage, substantially as specified.

2. The combination with a horn, of a die having a groove on its under face to receive

an outside formed lock seam, of a fixed gage having a groove on its upper face adapted to receive an inside formed lock seam, a movable gage and an intermediate gage adapted to act either as a movable gage or as a fixed gage, substantially as specified.

3. The combination with a horn, of a fixed gage, a movable gage and an intermediate gage adapted to act either as a movable gage or as a fixed gage, springs for supporting said movable gage, springs for supporting said intermediate gage as a movable gage and means for fixing said intermediate gage in its retracted position, substantially as specified.

4. The combination with a horn, of a fixed gage, a movable gage and an intermediate gage adapted to act either as a movable gage or as a fixed gage, springs for supporting said movable gage, springs for supporting said intermediate gage as a movable gage and means for fixing said intermediate gage in its retracted position, said

means consisting in a holding down pin or rod furnished with a threaded nut for retracting said intermediate gage, substantially as specified.

5. The combination with a horn, of a fixed gage, a movable gage and an intermediate gage adapted to act either as a movable gage or as a fixed gage, springs for supporting said movable gage, springs for supporting said intermediate gage as a movable gage and means for fixing said intermediate gage in its retracted position, said means consisting in a holding down pin or rod furnished with a threaded nut for retracting said intermediate gage, said horn having a socket to receive the threaded nut of the holding down pin or rod, substantially as specified.

JOHN KOHKE.

Witnesses:

T. H. STEWART,
O. S. COOK.