



(12) UK Patent (19) GB (11) 2 125 099 B

(54) Title of invention

Swivel hook assembly

(51) INT CL⁴: A44B 13/02

(21) Application No
8319889

(22) Date of filing
25 Jul 1983

(30) Priority data

(31) 57/112285

(32) 23 Jul 1982

(33) Japan (JP)

(43) Application published
29 Feb 1984

(45) Patent published
10 Jul 1985

(52) Domestic classification
E2A 408 HC
U1S 1801 E2A

(56) Documents cited
GB 1369201
GB 0652078

(58) Field of search
E2A

(73) Proprietor
Nippon Notion Kogyo Co. Ltd.
(Japan),
13 2-chome
Kanda-Sakuma-cho
Chiyoda-ku
Tokyo
Japan

(72) Inventor
Kazumi Kasai

(74) Agent and/or
Address for Service
Marks & Clerk,
57-60 Lincoln's Inn Fields
London WC2A 3LS

FIG. 1

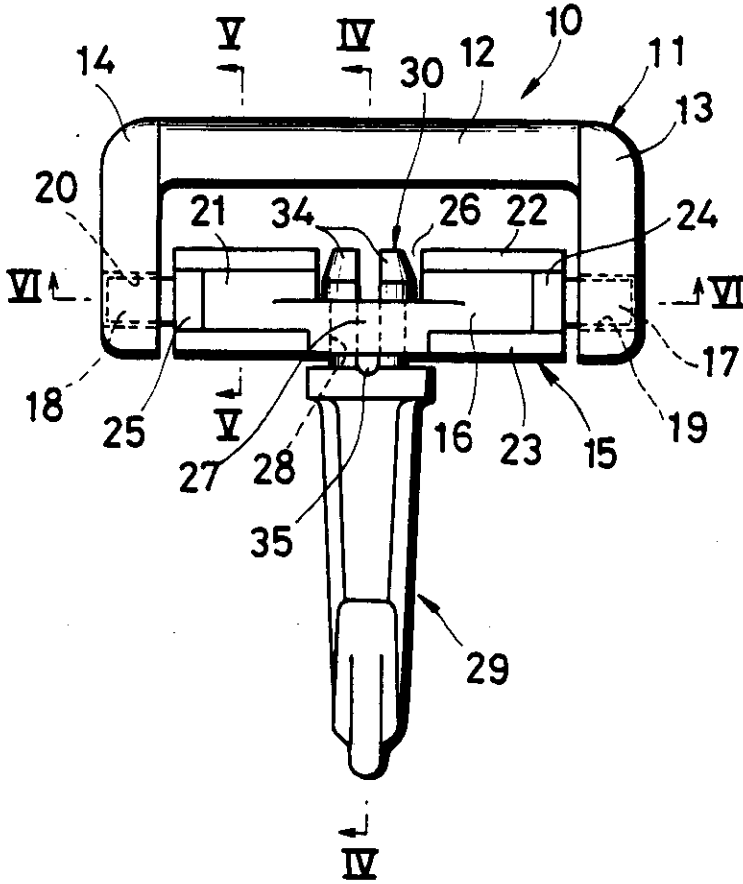

FIG. 2

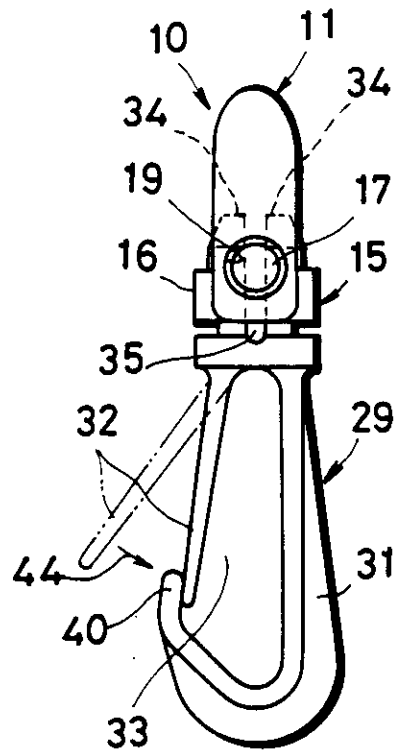

FIG. 3

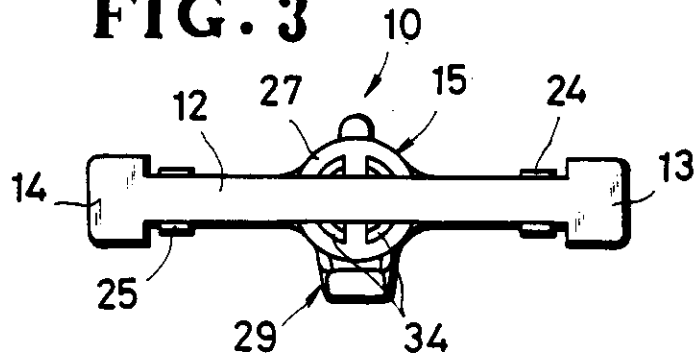

FIG. 4

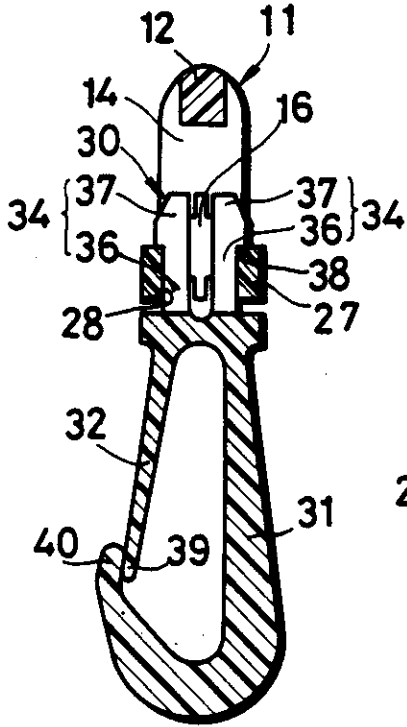

FIG. 5

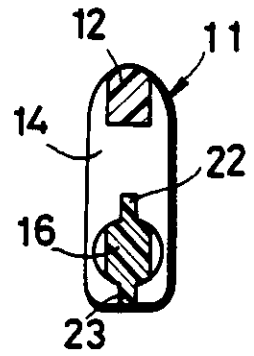

FIG. 6

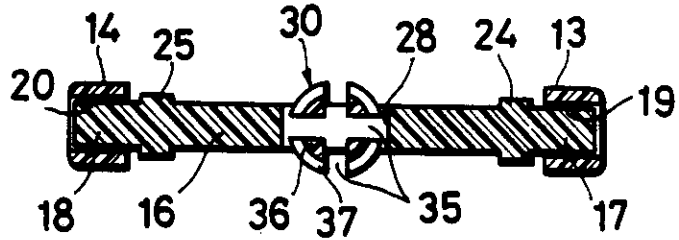

FIG. 7

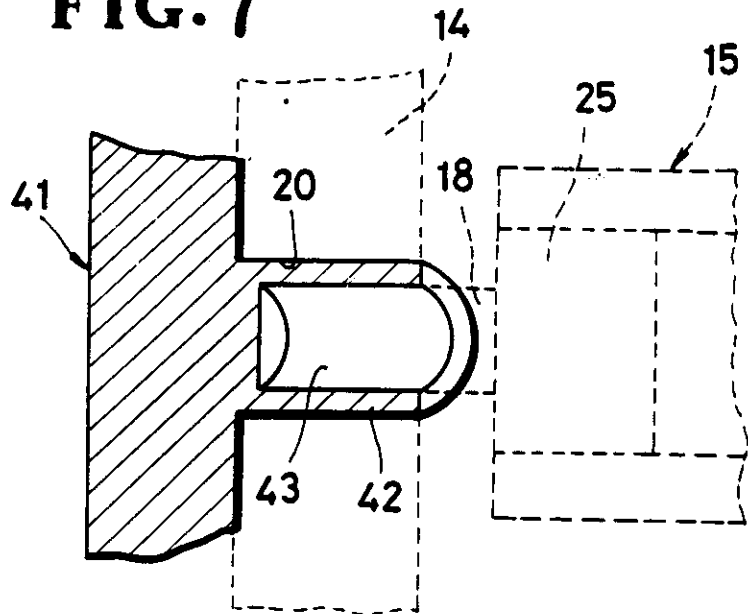

FIG. 8

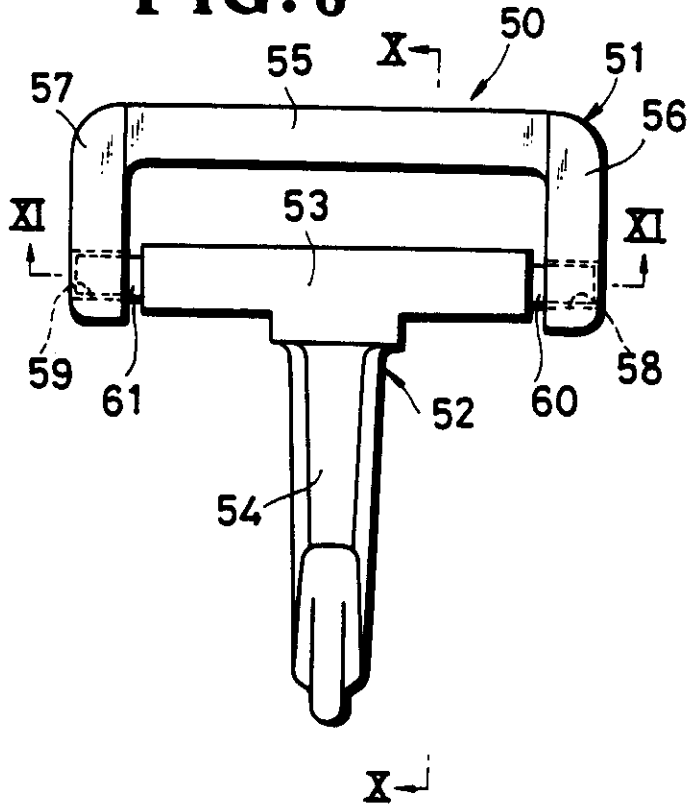

FIG. 9

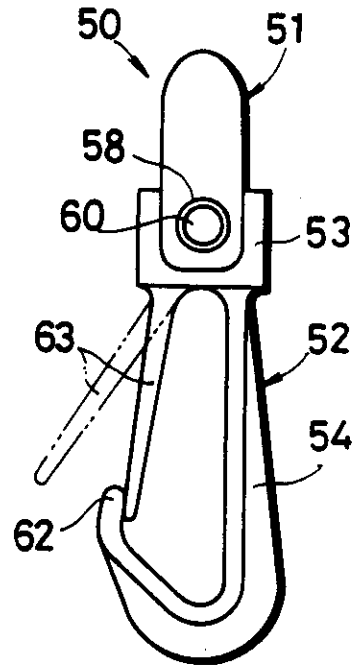

FIG. 10

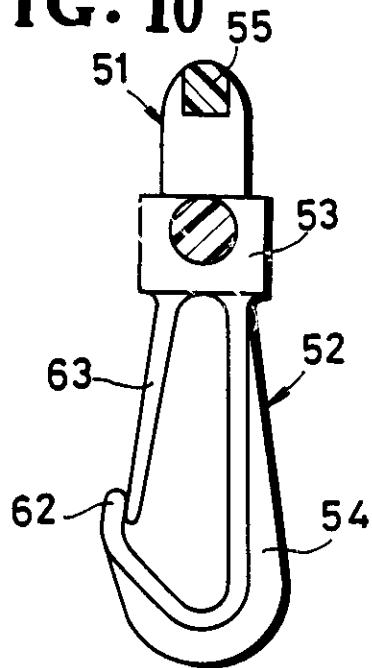
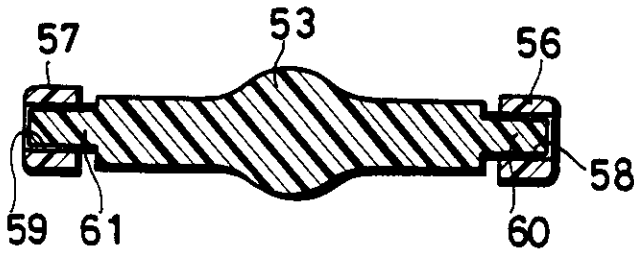

FIG. 11



- 1 -

SWIVEL HOOK ASSEMBLY

The present invention relates to a swivel hook assembly made of synthetic resin for use on a carrying strap of a bag, for example.

There have been proposed and used various
5 swivel hook assemblies made of metal or synthetic resin for attachment to an end of a carrying strap of a bag such as a shoulder bag. The swivel hook assemblies mainly comprise a connector to be attached to the strap and an openable hook rotatably joined to the connector.
10 The prior devices require an additional retaining member by which the hook and the connector are rotatably coupled together through a swivel connection. The known swivel hook arrangements are constructed of relatively many parts, should be assembled in an
15 increased number of steps, and hence are costly to manufacture. The swivel hooks of metal are additionally disadvantageous in that they cannot easily be colored to meet user's demands for fashionably colored products, and, for this reason, are not

suitable for use on shoulder bags, travelling bags and the like.

It is believed to be possible by means of the present invention to provide a swivel hook assembly which is made
5 of relatively few components, easy and less costly to assemble, lightweight, and can easily be colored to meet user's preferences for fashionable color combinations.

According to the present invention, there is provided a swivel hook assembly of synthetic resin for
10 use on a strap, comprising: a) a connector adapted for attachment to the strap and having a bar and a pair of legs joined to said bar at opposite ends, respectively, thereof and having a pair of holes defined respectively therein; b) an elongate support spaced transversely
15 from said connector and having on opposite ends, respectively, thereof a pair of coaxial shafts rotatably fitted in said holes respectively; and c) a hook mounted on said elongate support and including a hook body having a distal end and defining an opening,
20 and a locking bar resiliently engageable with said distal end for closing said opening.

The invention will be described by way of examples with reference to the accompanying drawings in which:-

3.

Figure 1 is a front elevational view of one swivel hook assembly embodying of the present invention;

Figure 2 is a side elevational view of the swivel hook assembly shown in Figure 1;

5 Figure 3 is a plan view of the swivel hook assembly of Figure 1;

Figure 4 is a cross-sectional view taken along line IV -IV of Figure 1;

10 Figure 5 is a cross-sectional view taken along line V - V of Figure 1;

Figure 6 is a cross-sectional view taken along line VI - VI of Figure 1;

15 Figure 7 is a perspective view, partly in cross section, of a mold die employed for molding parts of the swivel hook assembly illustrated in Figure 1;

Figure 8 is a front elevational view of a second swivel hook assembly embodying the present invention;

Figure 9 is a side elevational view of the swivel hook assembly shown in Figure 8;

20 Figure 10 is a cross-sectional view taken along line X - X of Figure 8; and

Figure 11 is a cross-sectional view taken along line XI - XI of Figure 8.

As shown in Figures 1 through 3, a swivel hook

assembly 10 has a connector 11 of an inverted U shape composed of a horizontal bar 12 and a pair of laterally spaced legs 13, 14 mounted on the connector 11 at opposite ends thereof and extending vertically downwardly parallel to each other. The horizontal bar 12 and the vertical legs 13 are integrally molded of synthetic resin. The bar 12 will be attached to an end of a carrying or shoulder strap of a bag, for example. The bar 12 is thinner than the legs 13, 14, as illustrated in Figure 3.

The swivel hook assembly 10 also comprises a horizontal elongate support 15 of synthetic resin spaced downwardly from the horizontal bar 12 in parallel relationship and including a central portion 16 and a pair of coaxial shafts 17, 18 extending from opposite ends thereof. The shafts 17, 18 are rotatably journaled respectively in holes 19, 20 defined in the legs 13, 14. Therefore, the support 15 is rotatable relatively to the connector 11 about the axes of the shafts 17, 18.

The central portion 16 includes a main body 21, a pair of upper and lower thinner ribs 22, 23 on the main body 21, and a pair of end flanges 24, 25 on opposite ends of the main body 21, the shafts 17, 18 projecting from the flanges 24, 25, respectively. The central portion 16 has a recess 26 defined longitudinally centrally therein and extending from an

upper edge of the central portion 16 transversely to a substantially central position therein. The central portion 16 also includes a horizontal circular seat 27 disposed downwardly of the recess 26 and projecting
5 transversely on opposite sides of the central portion 16, the horizontal circular seat 27 having an upper surface lying flush with the bottom of the recess 26. The horizontal circular seat 27 has a central vertical through hole 28 coaxial therewith in communication with
10 the recess 26. The through hole 28 has a diameter smaller than the length of the recess 26 in the longitudinal direction of the central portion 16.

A hook 29 comprises a head 30, a hook body 31 extending downwardly from the head 30, and a locking
15 bar 32 extending downwardly from the head 30 for closing an opening 33 defined by the hook body 31, the head 30, the hook body 31 and the locking bar 32 being integrally molded of synthetic resin. As better shown in Figures 3 and 6, the head 30 is composed of four
20 locking members 34 angularly equally spaced and separated by a cross-shaped slot 35. Each of the locking members 34 has a neck 36 and a retainer 37 tapered off toward its end remote from the neck 36, the retainer 37 having a downwardly facing shoulder 38. The
25 locking bar 32 has an upper end integral with the head 30 and a lower distal end 39 engageable with a distal end 40 of the hook body 31.

The head 30 has a diameter around the necks 36 which is slightly smaller than the diameter of the hole 28 in the horizontal circular seat 27, and a maximum diameter around the locking members 34 which is larger than the diameter of the hole 28. The axial length of the retainers 37 is such that when they are placed on the circular seat 27 with the necks 36 in the hole 28, the retainers 37 do not project out of the recess 26.

For mounting the hook 29 on the support 15, the retainers 37 are forced through the hole 28 while the locking members 34 resiliently flex radially inwardly in the hole 28 until the retainers 37 emerge out of the hole 28, whereupon the retainers 37 snap radially outwardly with the shoulders 38 thereof held against the upper surface of the circular seat 27 and the bottom of the recess 26. The necks 36 of the head 34 are now located within the hole 28. Once the retainers 37 are fully positioned in the recess 26, they are prevented by the shoulders 38 from slipping out through the hole 28. Therefore, the hook 29 is securely mounted on the support 15. Since the diameter of the head 30 around the necks 36 is smaller than the diameter of the hole 38, the hook 29 can rotate about its own axis with respect to the support 15. The support 15 as mounted on the connector 11 is also rotatable about the axes of the shafts 17, 18. This construction allows the hook 29 to rotate about two

perpendicular axes relative to the connector 11.

Figure 7 illustrates a mold die 41 for simultaneously molding one of the legs 14 and a corresponding one of the shafts 18 placed therein in one step of molding operation. The mold die 41 includes a hollow cylindrical projection 42 having an outer peripheral profile complementary to the hole 20 in the leg 14 and an inner cylindrical cavity 43 complementary in shape to the shaft 18, the hollow cylindrical projection 42 having an axial length equal to the thickness of the leg 14. During molding operation, the shaft 18 is formed in the cavity 43 while at the same time a cylindrical surface of the leg 14 defining the hole 20 is formed by the outer periphery of the hollow cylindrical projection 42. Another identical mold die is employed to mold the leg 13 and the associated shaft 17 at the same time. These two mold dies are part of a mold die assembly for simultaneously molding the connector 11 and the support 15 in an assembled state.

The connector 11 and the support 15 can therefore be combined with each other in a single step of molding operation. The support 15 thus molded simultaneously with the connector 11 is nevertheless rotatable relatively to the connector 11. With such an arrangement, no separate steps of molding the connector 11 and the support 15 and then assembling them together

are necessary. After the connector 11 and the support 15 have been molded in a combined state, the hook 29 is mounted on the support 15 in the manner described above. Consequently, the overall process for assembling the swivel hook assembly 10 is quite simplified and much less costly as only the hook 29 needs to be attached to the support 15 that has already been combined with the connector 11 in a molding process.

10 The hook 29 is molded separately from the connector 11 and the support 15. A mold die for forming the hook 29 has mold cavities respectively for molding the hook body 31 in the solid-line position shown in Figure 2 and the locking bar 32 in the
15 two-dot-and-dash-line position. As molded, therefore, the locking bar 32 has its distal end spaced from the distal end 40 of the hook body 31. The locking bar 32 as thus formed is then elastically bent from the two-dot-and-dash-line position in a direction normal to
20 the sheet of Figure 2, and forced against its own resiliency in the direction of the arrow 44 to the solid-line position in which the distal end of the locking bar 32 is engaged by the distal end 40. The distal end of the locking bar 32 is now forcibly
25 pressed against the distal end 40 under the resiliency of the locking bar 32.

The swivel hook assembly 10 is composed of a

reduced number of parts, that is, only the connector 11, the support 15, and the hook 29, and can be assembled with utmost ease and less costly. Since all of the components are made of synthetic resin, they can be injection-molded in large quantities and hence inexpensively, can be colored as desired to meet user's various color preferences in vogue.

Figures 8 through 11 show a swivel hook assembly, generally indicated at 50, according to another embodiment of the present invention. The swivel hook assembly 50 is composed of a connector 51 of an inverted U shape and an integral T-shaped hook and support combination 52 having a horizontal support 53 and a hook 54. The connector 51 has a horizontal bar 55 and a pair of laterally spaced legs 56, 57 with holes 58, 59 defined therein, respectively, in coaxial alignment. The horizontal support 53 includes a pair of opposite shafts 60, 61 rotatably fitted in the holes 58, 59, respectively. The T-shaped hook and support combination 52 is therefore rotatable about the axes of the shafts 60, 61 relatively to the connector 51. The hook 54 has an upper end integrally joined to the support 53 and extends perpendicularly from a longitudinally central portion of the horizontal support 53.

The connector 51 and the hook and support combination 52 can be integrally molded of synthetic

resin simultaneously in a single step of operation by a mold die assembly including mold dies such as shown in Figure 7. As molded, the hook and support combination 52 is rotatable about the axes of the shafts 60, 61
5 relatively to the connector 51. The hook 54 has a distal end 62 and a locking bar 63 which is resiliently brought into engagement with the distal end 62 as shown in Figure 9, after the hook 54 has been molded. The swivel hook assembly 50 is composed of only two parts,
10 the connector 55 and the hook and support combination 52 which are molded at the same time in an assembled condition. The only step of completing the swivel hook assembly 50 is to engage the locking bar 63 with the distal end 62 of the hook 54. Therefore, the swivel
15 hook assembly 50 can more easily be fabricated than the swivel hook assembly 10 illustrated in Figure 1.

20

25

Claims:-

1. A swivel hook assembly of synthetic resin for use on a strap, comprising:

(a) a connector adapted for attachment to the strap and having a bar and a pair of legs joined to said bar at opposite ends, respectively, thereof and having a pair of holes defined respectively therein;

(b) an elongate support spaced transversely from said connector and having on opposite ends, respectively, thereof a pair of coaxial shafts rotatably fitted in said holes, respectively; and

(c) a hook mounted on said elongate support and including a hook body having a distal end and defining an opening, and a locking bar resiliently engageable with said distal end for closing said opening.

2. A swivel hook assembly according to claim 1, said elongate support extending substantially parallel to said bar of the connector.

3. A swivel hook assembly according to claim 1, said hook including a head from which said hook body extends, said head being rotatably supported on said elongate support.

4. A swivel hook assembly according to claim 3, said head being positioned substantially longitudinally centrally of said elongate support.

5. A swivel hook assembly according to claim 3, said elongate support having a longitudinally central recess and

a transverse through hole communicating therewith, said head having a plurality of angularly spaced locking members disposed in said central recess and said through hole and locked against removal out of said through hole.

5 6. A swivel hook assembly according to claim 5, said elongate support also including a circular seat through which said through hole extends coaxially, each of said locking member being composed of a neck positioned substantially in said through hole and a retainer having a
10 shoulder lockingly engaging said circular seat.

7. A swivel hook assembly according to claim 5, said locking members being four in number and separated from each other by a cross-shaped slot defined in said head.

8. A swivel hook assembly according to claim 5, said
15 head having a diameter around said necks which is smaller than a diameter of said through hole and a diameter around said retainers which is larger than the diameter of said through hole.

9. A swivel hook assembly according to claim 1, said
20 connector and said elongate support being simultaneously molded in a single step of molding operation in an assembled state.

10. A swivel hook assembly according to claim 1, said elongate support and said hook being molded integrally with
25 each other.

Publication No.
25099 A dated 20 February 1984

Patent Granted:

22 JA WITH EFFECT FROM 10 JUL 1983
SECTION 2-5(1)

Application No.
8319989 filed on 25 July 1983

Priority claimed:
23 July 1982 in Japan doc: 57/112285

Title:
Swivel hook assembly

Applicant:
Nippon Notion Kogyo Co Ltd (Japan), 13 2-chome Kanda-Sakuma-Cho, Chiyoda-Ku, Tokyo,
Japan.

Inventor:
Kazumi Kasai, 3105-1 Kamikoizumi, Namerikawa-shi, Toyama-ken, Japan.

Classified to:
E2A U1S

Examination requested 29 MAY 84

Address for Service:
Marks & Clerks, 57-60 Lincoln's Inn Fields, London WC2A 3LS.