

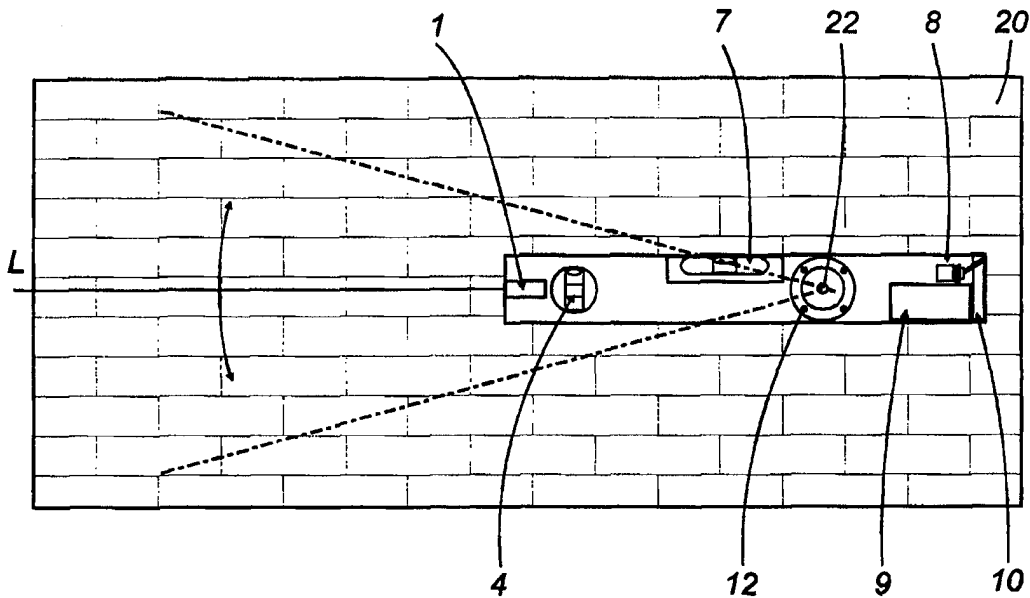

INTERNATIONAL APPLICATION PUBLISHED UNDER THE PATENT COOPERATION TREATY (PCT)

<p>(51) International Patent Classification ⁶ : G01C 15/00</p>	<p>A1</p>	<p>(11) International Publication Number: WO 98/51994 (43) International Publication Date: 19 November 1998 (19.11.98)</p>
<p>(21) International Application Number: PCT/IB98/00739 (22) International Filing Date: 15 May 1998 (15.05.98) (30) Priority Data: BO97A000293 15 May 1997 (15.05.97) IT (71)(72) Applicant and Inventor: MORETTI, Massimo [IT/IT]; Via Eynard, 37, I-48024 Massalombarda (IT). (74) Agent: LANZONI, Luciano; Bugnion S.p.A., Via dei Mille, 19, I-40121 Bologna (IT).</p>		<p>(81) Designated States: AU, BR, CA, CN, KR, US, European patent (AT, BE, CH, CY, DE, DK, ES, FI, FR, GB, GR, IE, IT, LU, MC, NL, PT, SE). Published <i>With international search report.</i> <i>With amended claims.</i></p>

(54) Title: INSTRUMENT FOR OBTAINING A REFERENCE LINE



(57) Abstract

Instrument for obtaining a reference line to realize, in correspondence of this line, working points, said working points being preferably situated in correspondence of a working surface. The instrument includes: a laser ray emitting device (1), a supporting body (13), connecting means which attach it to a fixed reference surface. These connecting means include a hinge element (2) which enables to orientate the supporting body (13) and direct the laser ray and to keep it fixed in the desired direction in such a way that with the line defined by the laser ray it is possible to find the working points.

FOR THE PURPOSES OF INFORMATION ONLY

Codes used to identify States party to the PCT on the front pages of pamphlets publishing international applications under the PCT.

AL	Albania	ES	Spain	LS	Lesotho	SI	Slovenia
AM	Armenia	FI	Finland	LT	Lithuania	SK	Slovakia
AT	Austria	FR	France	LU	Luxembourg	SN	Senegal
AU	Australia	GA	Gabon	LV	Latvia	SZ	Swaziland
AZ	Azerbaijan	GB	United Kingdom	MC	Monaco	TD	Chad
BA	Bosnia and Herzegovina	GE	Georgia	MD	Republic of Moldova	TG	Togo
BB	Barbados	GH	Ghana	MG	Madagascar	TJ	Tajikistan
BE	Belgium	GN	Guinea	MK	The former Yugoslav Republic of Macedonia	TM	Turkmenistan
BF	Burkina Faso	GR	Greece			TR	Turkey
BG	Bulgaria	HU	Hungary	ML	Mali	TT	Trinidad and Tobago
BJ	Benin	IE	Ireland	MN	Mongolia	UA	Ukraine
BR	Brazil	IL	Israel	MR	Mauritania	UG	Uganda
BY	Belarus	IS	Iceland	MW	Malawi	US	United States of America
CA	Canada	IT	Italy	MX	Mexico	UZ	Uzbekistan
CF	Central African Republic	JP	Japan	NE	Niger	VN	Viet Nam
CG	Congo	KE	Kenya	NL	Netherlands	YU	Yugoslavia
CH	Switzerland	KG	Kyrgyzstan	NO	Norway	ZW	Zimbabwe
CI	Côte d'Ivoire	KP	Democratic People's Republic of Korea	NZ	New Zealand		
CM	Cameroon			PL	Poland		
CN	China	KR	Republic of Korea	PT	Portugal		
CU	Cuba	KZ	Kazakstan	RO	Romania		
CZ	Czech Republic	LC	Saint Lucia	RU	Russian Federation		
DE	Germany	LI	Liechtenstein	SD	Sudan		
DK	Denmark	LK	Sri Lanka	SE	Sweden		
EE	Estonia	LR	Liberia	SG	Singapore		

Description

INSTRUMENT FOR OBTAINING A REFERENCE LINE

Technical Field

The present invention regards an instrument for obtaining a reference line to realize, in correspondence of this line, working points, said working points being preferably situated in correspondence of a working surface.

5

Background of the Invention

Presently, different instruments exist which use the rotation of a laser ray to project a laser ray on a surface. The single illuminous point on the surface is the measuring point.

10

Disclosure of the Invention

The instrument hereinafter illustrated is based on a different concept which does not use a ray of light projected on a wall in order to define a single illuminated point of measurement but uses the laser ray to obtain an entire reference line for a plurality of working points.

15

The present instrument is disclosed in claim 1.

In the present case the laser ray instrument is fixed, preferably as close as possible to the wall, with a particular fixing system which enables a regulation in order to obtain a real ray of light as a reference line.

20

By the presently shown preferred embodiment of the instrument, it is also possible to cut down sensibly on prices which derive from complicated pivoting systems of the prior art and as it is mounted directly on the reference surface also the tripod support costs are eliminated.

25

A system is provided which enables to resolve problems which all installers encounter when they have to mount in an alined way any type of apparatus or structure.

The dependent claims disclose particular and advantageous embodiments of the present invention.

To explain the use of the present system, it is described the practical use of the instrument which hereinafter will be referred to as "laser line".

5

Description of the Drawings

The preferred embodiment of the instrument and its preferred use are here described with reference to the enclosed drawings in which:

- Figure 1A is a side view of a preferable embodiment of the present invention;
- 10 - Figure 1B is an exploded view of the present instrument;
- Figures 2A, 2B, 2C are views of the present instrument in working conditions.

Description of the Illustrative Embodiment

Supposing that an electrician has to mount an external tube along a wall in order to be able to feed an electric socket, he has to make several holes and mount the attachments in order to sustain the tube, and lastly mount the box which houses the socket; everything correctly lined up.

15 Previously, to obtain what above said, it was necessary to carry out different measurements from different points of reference and make a lot of signs on the wall where the holes have to be made.

20 Otherwise, according to the present "laser line" it is only necessary to make a first hole, mount the first stopper and fix the "laser line" on it. The instrument can thereafter be directed in the desired direction, with the emitted laser ray which defines a line in correspondence of which the working points can be found.

25 By the present particular system, as illustrated in figures 2A, 2B, 2C, it is possible to direct the laser ray L in the desired direction, and eventually towards a point which is intended to be reached, while simultaneously keeping the ray close to (and when needed eventually parallel) the wall or working surface 20.

30 On this wall 20 it is possible to make holes or other signs of reference, by the user of the present instrument just in correspondence of the line defined by the laser ray. The laser ray should be kept at a few centimetres from the reference surface 20.

By this it is easy to obtain alined working holes as the point of the drill or other instrument is illuminated by the laser ray and this means that everything is perfectly alined.

When drilling, it is also possible to keep the position of the point under control avoiding the usual inconvenience of the drill moving at the beginning of said operation.

All of this enables a remarkable saving of time and a precise mounting.

The system has been provided with two water levels 7, 4 in order to direct the ray in a parallel or perpendicular way with regard to the ground.

More in detail, as illustrated in figures 1A and 1B, an alluminium bar 13 is the supporting body of the laser emitting device 1, on which also the two water levels 7 and 4 are mounted. Said levels provide or stabilize the perpendicularity or parallelism with respect to the ground of the ray of light emitted from the laser emitting device 1 or laser diode.

As it is evident from the figures, said laser ray has a virtual origin from the centre of the hinge or ball 2 defining the hinge. In fact, the centre of this hinge or ball 2 is alined with the ray emitted from the laser device 1.

The ball or sphere 2 enables the connecting of the supporting body 13 of the device 1 emitting the ray of light to a fixed reference surface (in this case the wall 20) providing a hinge element which enables, as illustrated by the dotted lines in figures 2A, 2B, 2C, to direct a laser ray substantially in all the spatial directions.

The connecting hinge 2 enables to orientate and mantain orientated the supporting body 13 in order to direct the laser ray and to keep the stated direction fixed, so that to trace, by the laser ray, the reference line along which the working points can be found.

The laser device 1 is mounted on the supporting body 13 (by a two-component resin). The device comprises also a lens which focuses the laser ray emitted by the laser diode. A miniature battery feeding system 9 is provided for feeding the laser emitting device 1.

Logically the resin will be introduced only after a careful regulation of the position of the laser system.

The hingedly connecting ball 2 is inserted in the supporting body 13 in respect of

which it is mobile with friction, due to the fact that it is held in a cavity 23 of the supporting body 13 by suitable means defined by two bushes or washers in nylon (6 and 5) opposite to each other.

5 The bushes or washers (6 and 5) are fixed to the supporting body 13 of the instrument by means of connecting screws 12, or in other suitable ways.

The supporting body 13 can be attached to the fixed reference by means of the hinge element or ball 2 with any kind of fixation means. Pivoting means are provided for connection of the hinge element 2 to the fixed reference.

10 The pivoting means have in the centre of the hinge or ball 2 a hole 22 in which a fixation screw 21, or other adapt fixation device, is inserted, in such a way to attach the present instrument to the fixed surface (in this case the wall 20).

15 The ball 2 being free to rotate in all positions and spatial directions, eventually only in a plane, and being held with friction by the two bushes and cavity 23, enables to direct and regulate the direction of the laser ray in substantially all the spatial, or planar, directions desired.

The switch 8 is inside the body of the laser line in such a way that it cannot be accidentally operated. The batteries 9 are two normal 1,5 volt ones and the taps 10 and 11 close the instrument at the ends of the body 13. As shown, the hinge element 2 is provided in the vicinity of one end of the support body 13.

Claims

- 1) Instrument used to obtain a reference line in order to make in correspondence of this line working points, said working points being preferably made on a working surface (20), characterized in that it comprises:
a device (1) for emitting a ray of laser light,
5 a supporting body (13) for said emitting device (1),
means (2, 22) for the connection of the supporting body (13) of the laser ray emitting device (1) to a fixed reference surface (20), said means (2, 22) of connection comprising a hinge element (2) which enables to orientate the supporting body (13) in order to direct the laser ray in the desired direction,
10 in such a way to trace with the laser ray a reference line along which the working points can be found.
- 2) Instrument according to claim 1, characterized in that the connecting means enable to direct the laser ray parallel to the working surface on which the working points are to be found.
- 15 3) Instrument according to any of the foregoing claims, characterized in that said connecting means are such to enable to direct the laser ray at a close distance from the working surface (20) on which the aligned fixed points are to be found.
- 4) Instrument according to any of the foregoing claims, characterized in that the
20 connecting hinge element (2) is a ball (2) mobile with friction in respect to the supporting body (13).
- 5) Instrument according to claim 4, characterized in that the supporting body
25 (13) presents a cavity (23) for the ball (2), means being provided for holding the mobile ball (2) with friction inside the cavity (23) in the supporting body (13).
- 6) Instrument according to any of the foregoing claims, characterized in that the holding means of the ball (2) include two bushes (5, 6) which are opposite each other, said bushes (5,6) being fixed to the body in correspondence to the cavity (23) and enclosing the mobile ball (2).
- 30 7) Instrument according to any of the foregoing claims, characterized in that, in

order to connect the hinge element (2) to the fixed reference surface (20), pivoting means are used to connect the hinge element (2) to the fixed reference surface (20).

- 5 8) Instrument according to claim 7, characterized in that the pivoting means include a central hole (22) in the hinge element (2) in order to receive suitable attachment means which attach the instrument to the fixed reference surface (20), said central hole (22) being alined with the laser ray emitted by the laser emitting device (1).
- 10 9) Instrument according to any of the foregoing claims, characterized in that the connecting hinge element (2) is situated in the vicinity of one end of the supporting body (13).
- 10) Instrument according to any of the foregoing claims, characterized in that, on the supporting body (13), means are provided to stabilize the directing of the ray emitted by the laser emitting device (1).
- 15 11) Instrument according to claim 10, characterized in that said means stabilizing the directing of the supporting body include at least one of two water levels (7, 4) attached to the supporting body (13) in order to draw out respectively a horizontal and a vertical alinement lines.
- 20 12) Instrument according to any of the foregoing claims, characterized in that batteries (9) for feeding the laser emitting device (1) are provided and in that a on/off switch (8) for controlling the laser device is provided.

AMENDED CLAIMS

[received by the International Bureau on 6 October 1998 (06.10.98);
original claims 1-12 replaced by new claims 1-14 (3 pages)]

- 1) Instrument used to obtain a reference line in order to make in
correspondence of this line working points, said working points being
preferably made on a working surface (20), said instrument
5 comprising
a device (1) for emitting a ray of laser light,
a supporting body (13) for said emitting device (1),
means (2, 22) for the connection of the supporting body (13) of the
laser ray emitting device (1) to a reference surface (20),
10 said means (2, 22) of connection comprising hinge means (2) which
enables to orientate the supporting body (13) in order to direct the
laser ray in the desired direction, in such a way to trace with the laser
ray a reference line along which the working points can be found,
characterized in that said connecting hinge means comprise a ball
15 (2) on which said supporting body (13) is mobile with friction.
- 2) Instrument according to claim 1 or according to the precharacterizing
part of claim 1, characterized in that the centre of rotation of the
hinge means is substantially aligned with the laser ray emitted by the
laser emitting device (1).
- 20 3) Instrument according to any of the foregoing claims, characterized in
that said connecting means are such to enable to direct the laser ray
at a close distance from the working surface (20) on which the aligned
fixed points are to be found.
- 4) Instrument according to the foregoing claims, characterized in that
25 the supporting body (13) presents a cavity (23) for the ball (2),
means being provided for holding the ball (2) with friction inside the
cavity (23) in the supporting body (13).
- 5) Instrument according to claim 4, characterized in that the holding
means of the ball (2) include two bushes (5, 6) which are opposite
30 each other, said bushes (5,6) being fixed to the body in

correspondence to the cavity (23) and enclosing the ball (2).

5 6) Instrument according to any of the foregoing claims or according to the precharacterizing part of claim 1, characterized in that pivoting means are used to attach the hinge means (2) to the reference surface (20).

7) Instrument according to claim 6, characterized in that the pivoting means include a central hole (22) in the hinge means (2) in order to receive suitable attachment means which attach the instrument to the reference surface (20).

10 8) Instrument according to claim 7, characterized in that said attachment means comprise a pivoting element (21) which is inserted into the central hole (22) of the hinge means (2) and is attachable to the reference surface.

15 9) Instrument according to any of the foregoing claims, characterized in that the connecting hinge means (2) is situated in the vicinity of one end of the supporting body (13).

20 10) Instrument according to any of the foregoing claims, characterized in that, on the supporting body (13), means (7, 4) are provided for orientating the ray emitted by the laser emitting device (1) in a desired direction.

25 11) Instrument according to claim 10, characterized in that said means for orientating the ray in a desired direction comprises at least one of two water levels (7, 4) attached to the supporting body (13) in order to draw out respectively a horizontal and/or a vertical alignment line.

30 12) Instrument according to any of the foregoing claims, characterized in that batteries (9) for feeding the laser emitting device (1) are provided and in that a on/off switch (8) for controlling the laser device is provided.

13) Instrument according to any of the foregoing claims or according to the precharacterizing part of claim 1, characterized in that said hinge

means are means for orientating the laser ray in spatial direction.

- 14) Instrument according to any of the foregoing claims 7 to 13 or according to the precharacterizing part of claim 1, characterized in that attaching means provided for attaching the instrument to a reference surface are means which resist to traction suitable for avoiding a freely sliding or falling of the instrument.

5

FIG. 1A

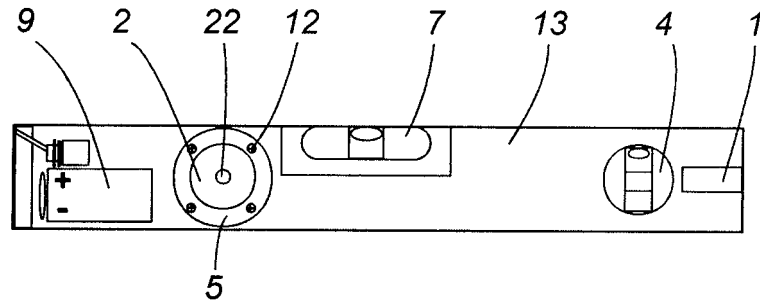

FIG. 1B

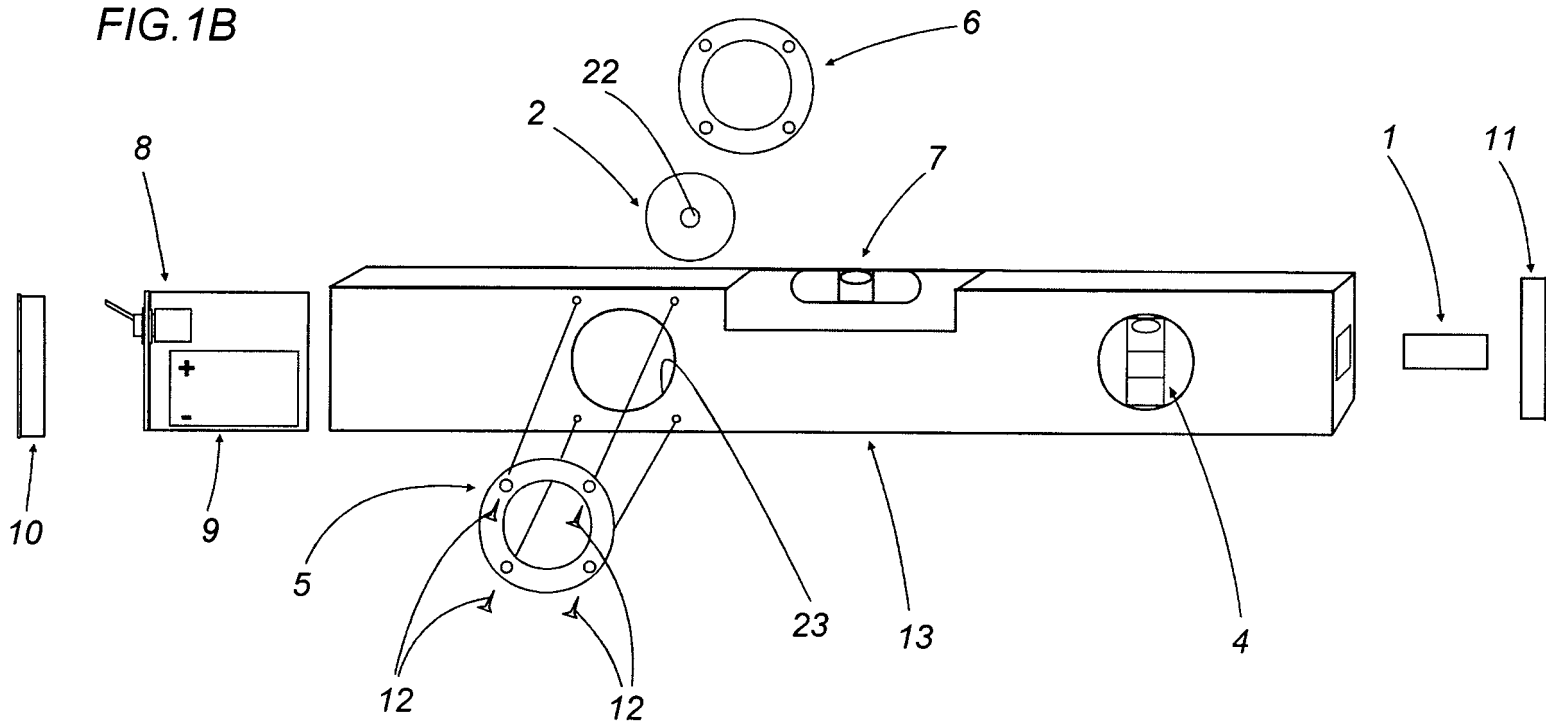

FIG.2B

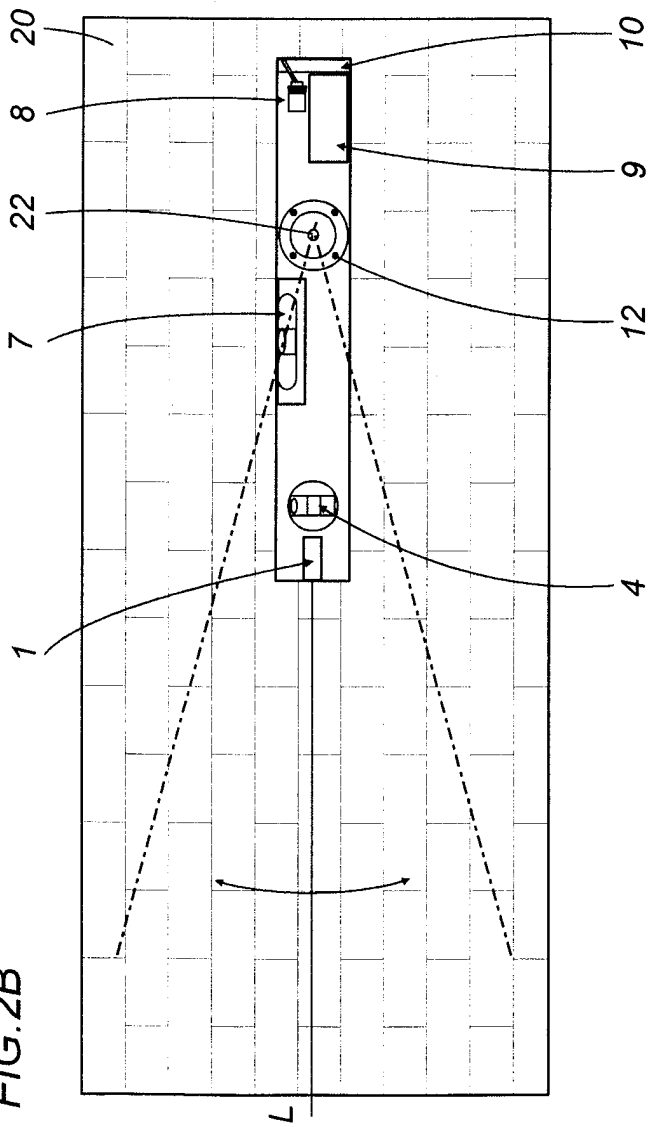

FIG.2C

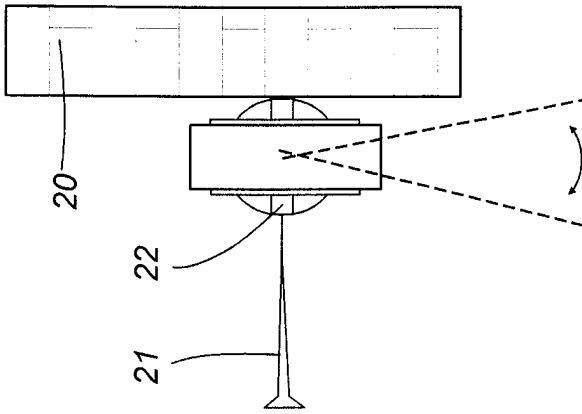
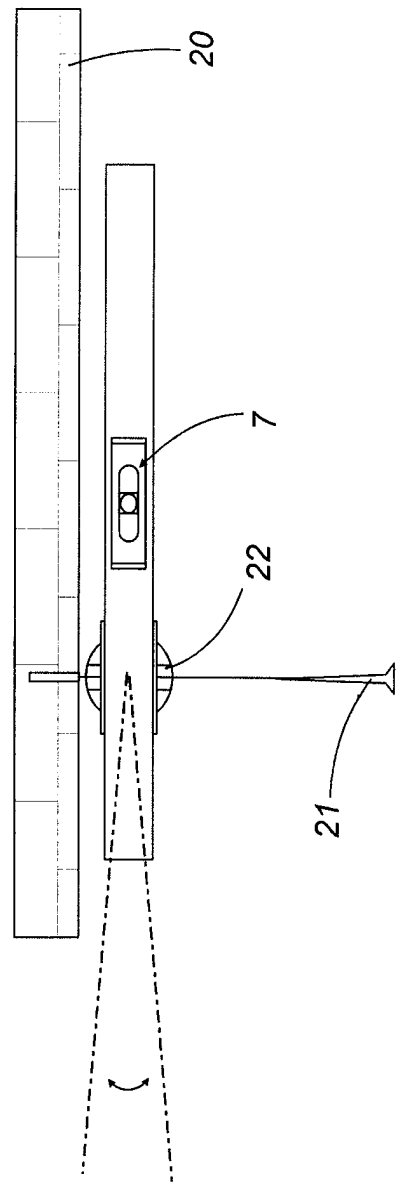

FIG.2A



INTERNATIONAL SEARCH REPORT

In .tional Application No

PCT/IB 98/00739

A. CLASSIFICATION OF SUBJECT MATTER
IPC 6 G01C15/00

According to International Patent Classification(IPC) or to both national classification and IPC

B. FIELDS SEARCHED

Minimum documentation searched (classification system followed by classification symbols)
IPC 6 G01C

Documentation searched other than minimum documentation to the extent that such documents are included in the fields searched

Electronic data base consulted during the international search (name of data base and, where practical, search terms used)

C. DOCUMENTS CONSIDERED TO BE RELEVANT

Category	Citation of document, with indication, where appropriate, of the relevant passages	Relevant to claim No.
X	EP 0 617 258 A (MICRO ITALIANA SPA) 28 September 1994 see the whole document	1,2,9-12
Y	---	3
Y	US 5 400 514 A (IMBRIE GARY J ET AL) 28 March 1995 see abstract; figure 1	3
A	---	
A	US 5 531 031 A (GREEN KEVIN D) 2 July 1996 see abstract; figures 1,7,8	1
A	---	
A	US 3 997 267 A (MET VIKTOR) 14 December 1976 see abstract; figure 4	1

Further documents are listed in the continuation of box C.

Patent family members are listed in annex.

° Special categories of cited documents :

- "A" document defining the general state of the art which is not considered to be of particular relevance
- "E" earlier document but published on or after the international filing date
- "L" document which may throw doubts on priority claim(s) or which is cited to establish the publication date of another citation or other special reason (as specified)
- "O" document referring to an oral disclosure, use, exhibition or other means
- "P" document published prior to the international filing date but later than the priority date claimed

- "T" later document published after the international filing date or priority date and not in conflict with the application but cited to understand the principle or theory underlying the invention
- "X" document of particular relevance; the claimed invention cannot be considered novel or cannot be considered to involve an inventive step when the document is taken alone
- "Y" document of particular relevance; the claimed invention cannot be considered to involve an inventive step when the document is combined with one or more other such documents, such combination being obvious to a person skilled in the art.
- "&" document member of the same patent family

Date of the actual completion of the international search

3 August 1998

Date of mailing of the international search report

07/08/1998

Name and mailing address of the ISA

European Patent Office, P.B. 5818 Patentlaan 2
NL - 2280 HV Rijswijk
Tel. (+31-70) 340-2040, Tx. 31 651 epo nl,
Fax: (+31-70) 340-3016

Authorized officer

Vorropoulos, G

INTERNATIONAL SEARCH REPORT

Information on patent family members

International Application No
PCT/IB 98/00739

Patent document cited in search report	Publication date	Patent family member(s)	Publication date
EP 0617258 A	28-09-1994	IT VI930044 A	26-09-1994
US 5400514 A	28-03-1995	NONE	
US 5531031 A	02-07-1996	NONE	
US 3997267 A	14-12-1976	JP 49053069 A	23-05-1974