

(No Model.)

2 Sheets—Sheet 1.

H. P. WATTS.

FAN ATTACHMENT FOR SEWING MACHINES.

No. 577,338.

Patented Feb. 16, 1897.

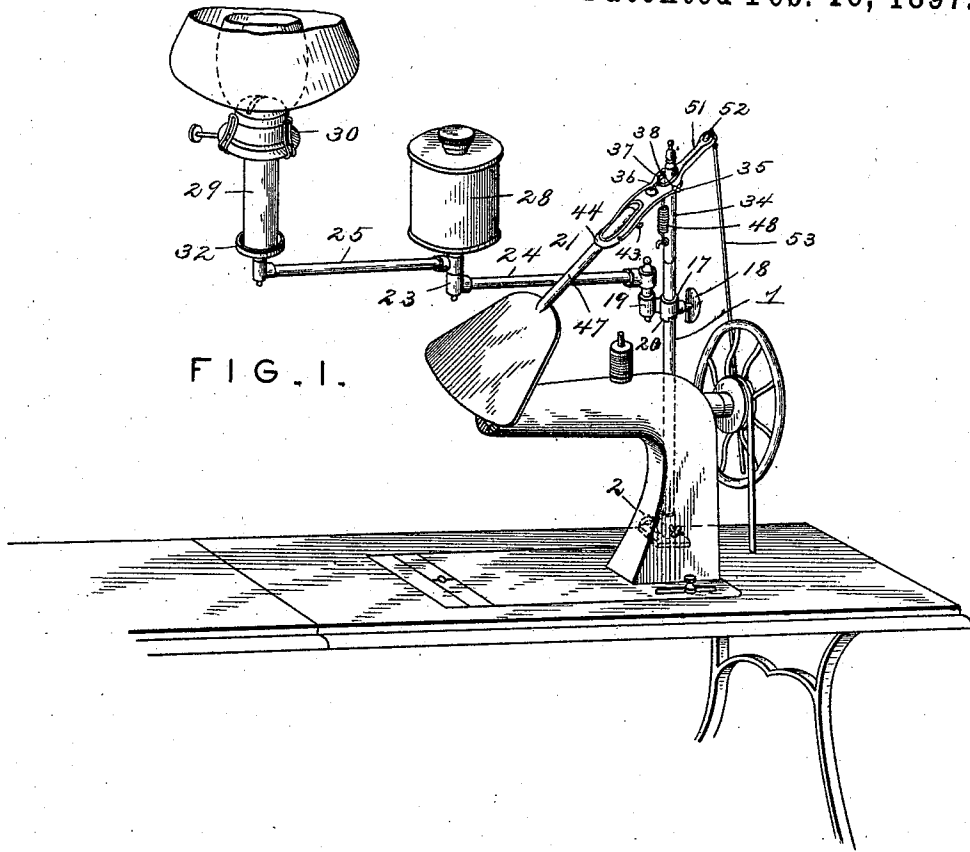

FIG. 1.

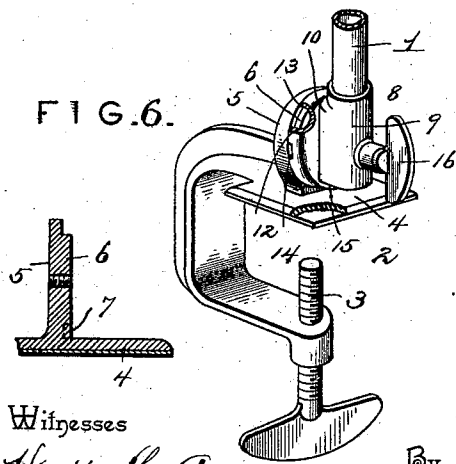

FIG. 6.

Witnesses
Harry L. Amer.
G. H. Maxwell.

By *His* Attorneys,

Inventor
Henry P. Watts.
Chas. H. Snow & Co.

(No Model.)

2 Sheets—Sheet 2.

H. P. WATTS. FAN ATTACHMENT FOR SEWING MACHINES.

No. 577,338.

Patented Feb. 16, 1897.

FIG. 2.

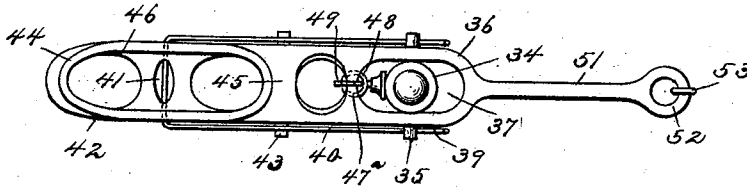

FIG. 3.

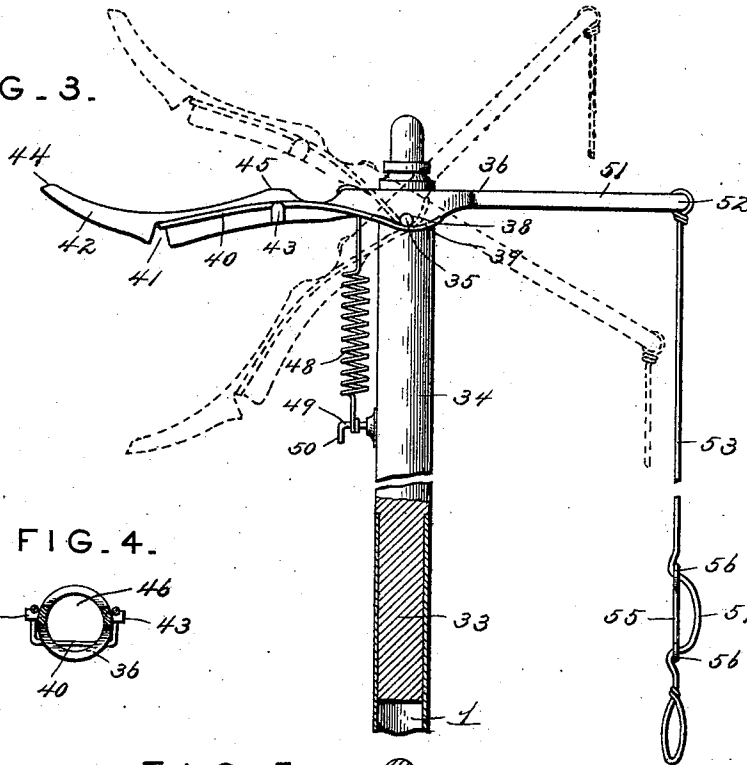

FIG. 4.

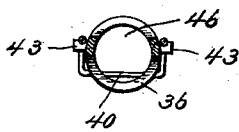

FIG. 5.

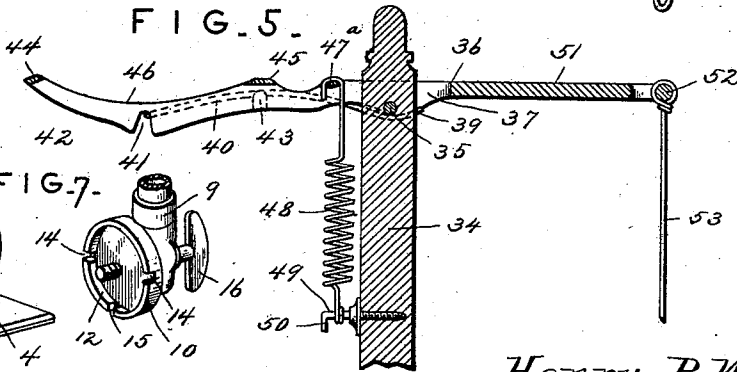
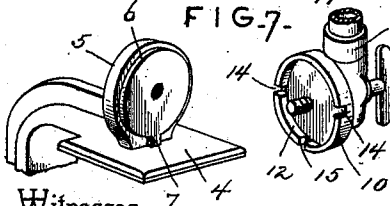

FIG. 7.



Witnesses

Harry L. Amer.
G. St. Maxwell.

Inventor

Henry P. Watts.

By *Chas.* Attorneys,

Chas. & Co.

UNITED STATES PATENT OFFICE.

HENRY PRESTON WATTS, OF LYNCHBURG, VIRGINIA, ASSIGNOR TO LIZZIE LILLIAN ADKERSON, OF SAME PLACE.

FAN ATTACHMENT FOR SEWING-MACHINES.

SPECIFICATION forming part of Letters Patent No. 577,338, dated February 16, 1897.

Application filed October 10, 1895. Serial No. 565,290. (No model.)

To all whom it may concern:

Be it known that I, HENRY PRESTON WATTS, a citizen of the United States, residing at Lynchburg, in the county of Campbell and State of Virginia, have invented a new and useful Fan Attachment for Sewing-Machines, of which the following is a specification.

This invention relates to fan attachments for sewing-machines; and it has for its object to provide a new and useful attachment of this character especially designed for use in connection with a lamp suitably supported out of the way of the operator.

To this end the main and primary object of the invention is to construct a novel fan attachment especially designed for use on a sewing-machine in connection with a lamp at night, whereby the operator may work under the light of a lamp, while at the same time have the benefit of the wind created by the operations of the fan attachment, the movement of the fan being so directed as to throw the wind on the operator's hands, thereby enabling the operator to safely work upon fine white fabrics at night in a hot room or in hot weather without danger of soiling the same by perspiration.

With this object in view the invention consists in the novel construction, combination, and arrangement of parts hereinafter more fully described, illustrated, and claimed.

Reference now being made to the drawings for the purpose of detailed description of my improved combination, Figure 1 is a perspective view of my invention. Fig. 2 is an enlarged plan view of the fan-operating mechanism. Fig. 3 is a side elevation. Fig. 4 is a cross-section. Fig. 5 is a longitudinal section of said fan mechanism. Fig. 6 is a perspective view of the base-clamp and adjacent standard adjustment with parts broken away to show details. Fig. 7 is a detail view of the connections between the standard and the base-clamp, the parts being separated.

Reference-numeral 1 designates a tubular standard which is provided at its lower end with a base-clamp 2, having a clamping thumb-screw 3 passing through its lower arm in longitudinal alinement with the middle of bearing-plate 4. Plate 4 extends horizontally from the upper arm of the clamp and is lined

on its under surface with soft leather or felt to prevent abrasion of polished surfaces against which said table-clamp 2 may be secured. Projecting perpendicularly from the upper side of plate 4 is a circular ear 5, which lies in a plane perpendicular to the plane of the table-clamp and provided on its inner face with a slightly-raised circular boss 6 and a lug or ridge 7 at its lower edge. On the lower end of standard 1 a suitable casting 8 is fixed by means of its collar 9, and is provided with a disk-face 10 at one side, which is dished out at 12 to snugly fit over boss 6, and its peripheral flange 13 is notched at each side at 14 and bottom 15, said notches adapted to fit over ridge 7, so as to hold the standard either vertically or horizontally. Thumb-screw 16 properly clamps the parts together.

Arranged to slide up and down on standard 1 and freely turning thereon is a sleeve 17, provided with set-screw 18 and arm 19 opposite thereto. Beneath arm 19 and depending in facial contact with the standard is a brace-flange 20, to give increased bearing-surface and thereby increased leverage to sustain the lamp-bracket 21. This lamp-bracket consists of two sections 24 and 25, arranged to swing at right angles to standard 1 and jointed together at 23. The outer section 25 is hollow and supports at its inner end the oil-fount 28. At its outer end section 25 is provided with a tube 29, supporting any ordinary lamp burner and trimmings 30. At its lower end the tube 29 is provided with a drip-cup 32 to catch such oil as may leak over the top by means of capillary attraction or otherwise.

In the tubular top of standard 1 tenon 33 of fan-post 34 is tightly fitted, so as to turn hard in said top. Just below its ornamental top this post is provided with a transverse axle 35, projecting at either side to receive the fan-lever 36. This lever is provided with a central elongated slot 37, fitting over post 34, whose sides are arranged to oscillate in close contact with either side of said post and are provided with semicircular bearing 38 midway of their lower edge to receive the stub-axes 35. Bearings 38 are held in certain contact over axles 35 by means of the bent-ends 39 of spring 40, which are passed un-

der the axles 35. This spring is formed of one piece of wire bent U shape and arranged with its middle bend in notch 41 on the depressed under side of the fan end 42 of lever 5 36 and with its parallel sides sprung up over the horizontal lugs 43, which project laterally from end 42 about midway between notch 10 41 and the bearing-axles 35. Lever 36 is further formed at its fan end 42 by an outer extension 44, arched at its outer end to correspond with arch 45 above lugs 43. A longitudinal bore 46 is provided through extension 15 44 and arch 45 and the intervening parts, so as to form a light walled socket for the fan-handle 47. From Fig. 4 it will be noticed that notch 41 is sufficiently deep to allow 20 spring 40 to cross said bore or fan-socket 46. This arrangement is provided as a means to clamp the fan-handle in place. In order to insert the handle in socket 46, the spring 40 must be wedged out of the way. The handle is then forced back underneath arch 45, and the spring 40 flies up against its under side to clamp it firmly in place.

25 The rear portion of arch 45 is cut away so as to leave a slender wall 47^a, over which the upper end of the helically-coiled spring 48 may be hooked. This spring at its lower end is looped over pin 49 and held in place by the 30 downturned end 50 of said pin. This pin projects from post 34, adjacent the standard 1, so as to bring spring 48 always under tension to pull down the fan end 42 of lever 36. To counteract this downward pull, lever 36 is provided with a rearwardly-projected arm 51, to the terminal eye 52 of which is secured the upper end of operating-rope 53. The 35 lower end of rope 53 is provided with a small wire link 55, provided with an eye 56 at either end threaded on said rope, as shown, by means of which a loop 57 may be adjusted over the 40 treadle or other convenient moving part of a machine, so as to operate said rope. Thus by the downward pull of rope 53 the fan is moved up, and the instant the rope is slackened spring 48 pulls said fan down, and the 45 repeated pulling of the rope keeps up the fanning.

From the above detailed explanation it is obvious that my attachment may be clamped 50 to any suitable place and adjusted horizontally or vertically by thumb-screw 16. The lamp may then be swung on its jointed arm 21 into any position and adjusted along or around the standard by set-screw 18. The 55 fan is then clamped into its socket 46 by the spring 40. The rope is secured by loop 57 to the treadle or wheel of the sewing-machine, (if used in that connection.)

What I claim is—

1. An attachment for sewing-machines, comprising a standard having provision whereby it may be attached to the machine-table and provided at or near its upper end with a transverse axle, a fan-lever having 65 bearing-slots at its under side by which it is fulcrumed on said axle, a spring carried by the fan-lever and having curved portions which engage beneath the ends of the axle for holding the fan-lever in position, and 70 means connecting said lever to one of the machine-wheels whereby motion is imparted to the fan, substantially as described.

2. An attachment for sewing-machines, comprising a standard having provision 75 whereby it may be attached to the machine-table and provided at or near its upper end with a transverse axle, a fan-lever fulcrumed on said axle and provided near one end with longitudinal slots or openings for the recep- 80 tion of the fan-handle and also having its end arched to embrace said handle, a spring mounted on the fan-lever and having a transverse portion which passes under the fan-handle and frictionally engages the same for 85 holding it in place, and means connecting said lever to an operative part of the machine whereby motion is imparted to the fan, substantially as described.

In testimony that I claim the foregoing as 90 my own I have hereto affixed my signature in the presence of two witnesses.

HENRY PRESTON WATTS.

Witnesses:

JNO. G. HAYTHE,

W. R. PERKINS.