

J. H. LINVILLE.
ELECTRIC MOTOR.

No. 355,771.

Patented Jan. 11, 1887.

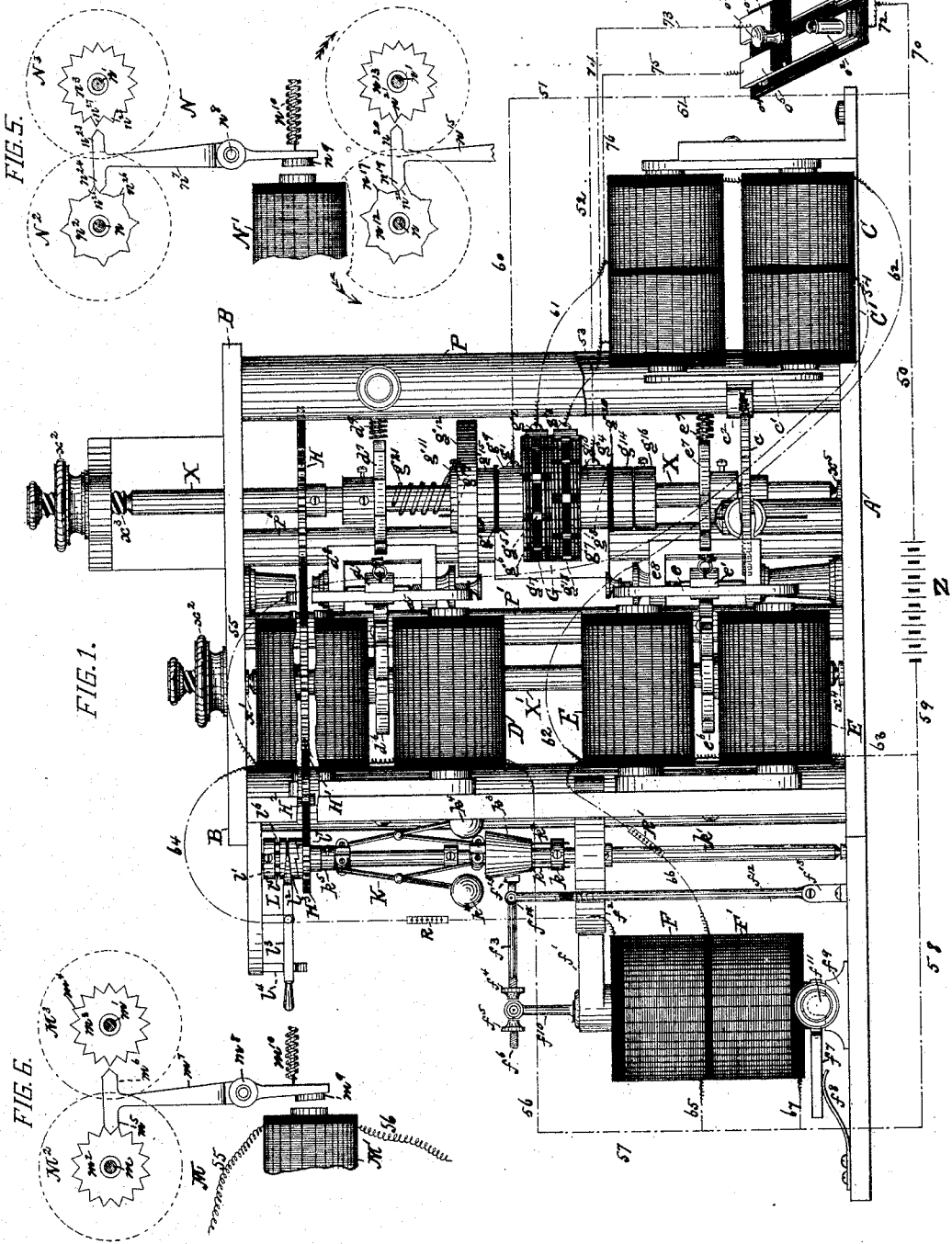

WITNESSES:

Herman Borman.
Thomas M. Smith.

INVENTOR

Jacob H. Linville,
by his Attorney,
J. Walter Douglas.

J. H. LINVILLE.

ELECTRIC MOTOR.

No. 355,771.

Patented Jan. 11, 1887.

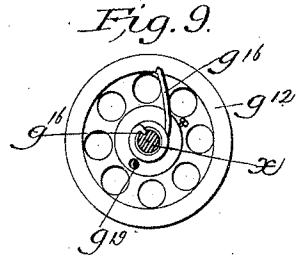
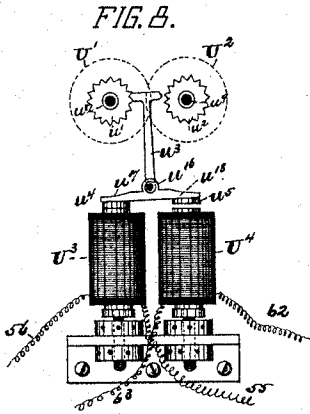
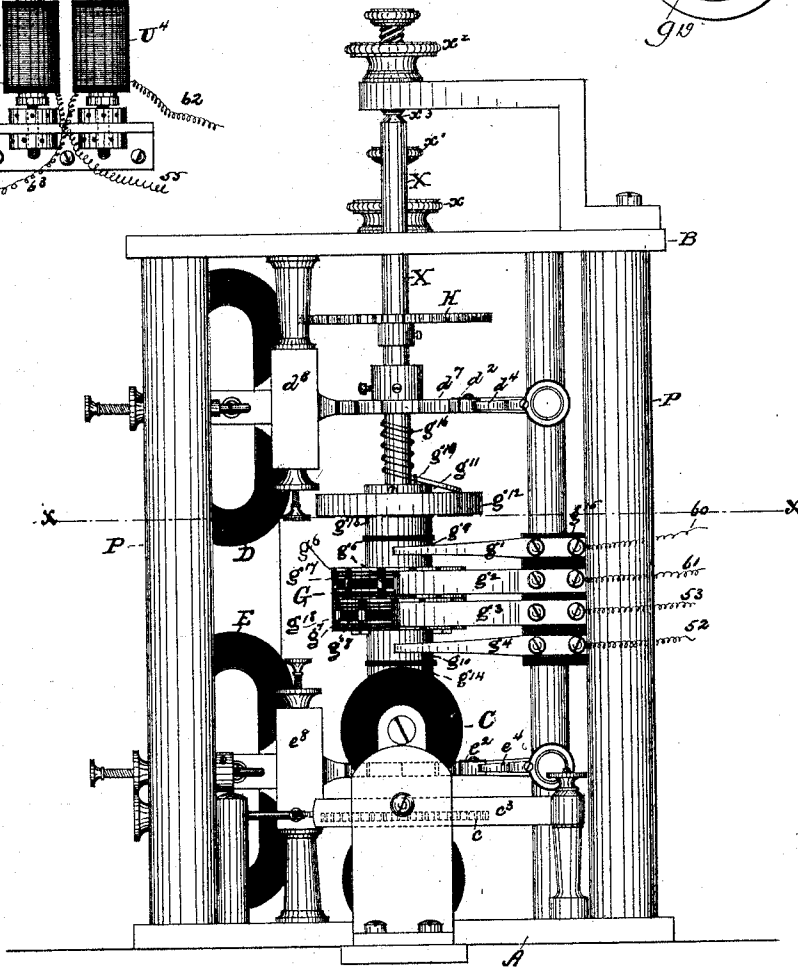

FIG. 2.



WITNESSES:
Herman Borman,
Thomas M. Smith.

INVENTOR:
Jacob H. Linville,
by his Attorney,
Albion S. Douglas

J. H. LINVILLE.
ELECTRIC MOTOR.

No. 355,771.

Patented Jan. 11, 1887.

FIG. 7.

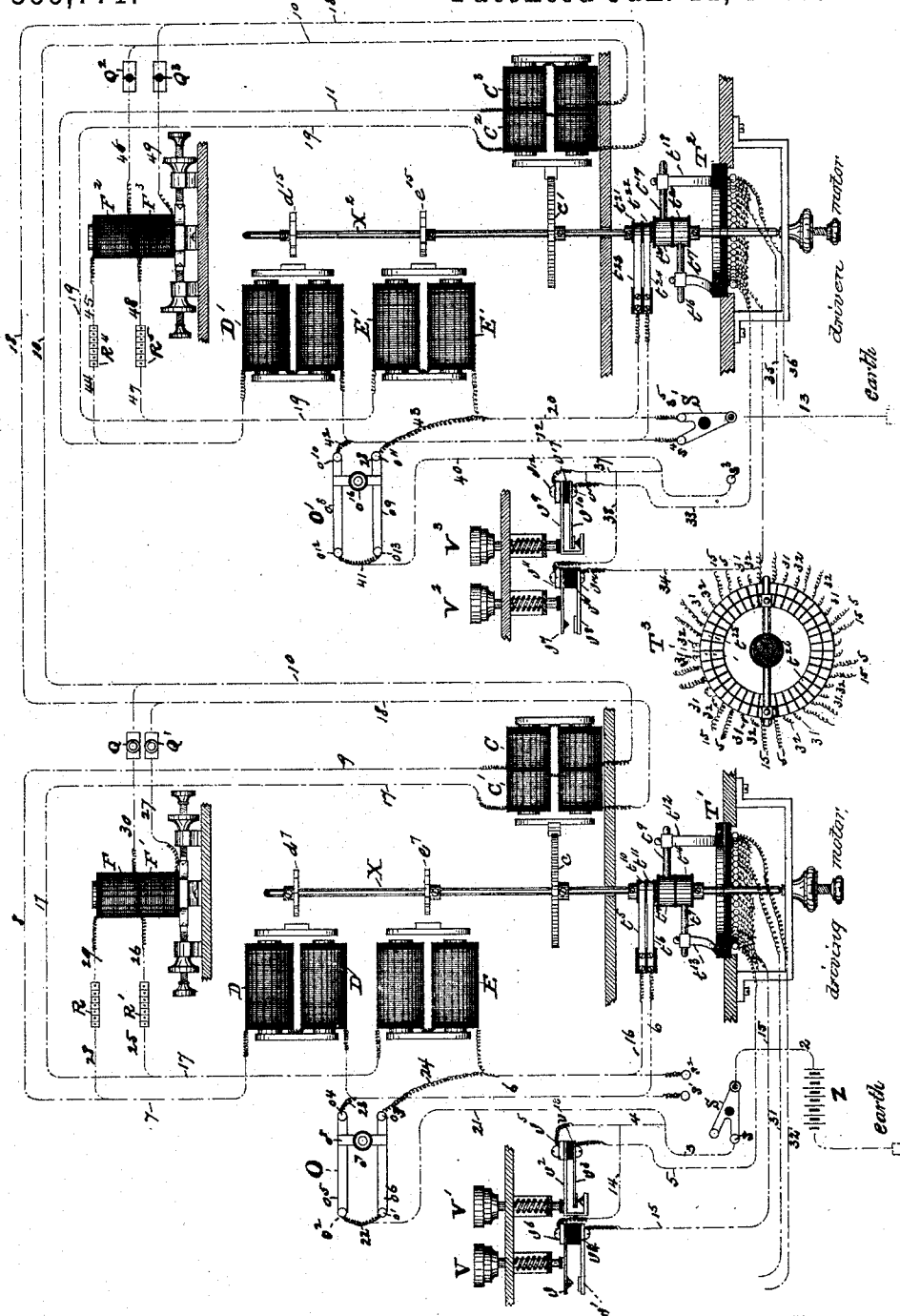

WITNESSES:
Herman Bernau.
Thomas M. Smith.

INVENTOR:
Jacob H. Linville.
By his Attorney,
J. Walter Douglas.

UNITED STATES PATENT OFFICE.

JACOB H. LINVILLE, OF PHILADELPHIA, PENNSYLVANIA, ASSIGNOR TO THE INTERNATIONAL PRINTING TELEGRAPH COMPANY, OF CAMDEN, N. J.

ELECTRIC MOTOR.

SPECIFICATION forming part of Letters Patent No. 355,771, dated January 11, 1887.

Application filed March 13, 1886. Renewed December 13, 1886. Serial No. 231,490. (No model.)

To all whom it may concern:

Be it known that I, JACOB H. LINVILLE, of the city and county of Philadelphia, in the State of Pennsylvania, have invented certain new and useful Improvements in Electromotors, of which improvements the following is a specification.

My invention relates to step-by-step electromotors, and means for controlling their speed, and for operating similar motors in series in the same electrical circuit.

The object of my invention is to provide a rapid and reliable step-by-step electromotor, which shall be automatic in its movement and regulation, and applicable to printing-telegraphs and other apparatus where a step-by-step movement is required; and to which ends it consists in connecting by similar gearing two shafts carrying star or ratchet wheels, in order that these wheels may move in opposite directions at similar speed and alternately present ratchet or star wheel indentations to the pawl or wedge pallets on their respective levers vibrated alternately and successively by the respective armatures as their electro-magnets are successively and alternately energized, the motion imparted thereby to one wedge-pallet scape or ratchet wheel on one shaft being communicated through similar gearing to the other wedge-pallet scape or ratchet wheel and shaft. By this arrangement and organization the respective pawls or pallets on each lever act with equal leverage and an equal angular motion is imparted to the ratchet or star wheels by the vibrations of the levers, which is not the case when the pawls and pallets act alternately on a ratchet or star wheel secured to a single shaft. The revolution of the shafts, caused by the action of the electro-magnets with their armatures, levers, and pawls or pallets, rotates a circuit-pulsator to automatically close and break the circuits through the electro-magnets at the instant when the armatures have just completed their respective backward and forward movement, resulting in a continuous step-by-step rotation of the respective shafts until arrested by a continued make or break of circuit. When by the depression of a double-line key the circuit is simultaneously closed in both conductors through a differential electro-magnet, the shafts and elec-

tromotor will be arrested through the action of this electro-magnet.

The electromotor may be organized to operate with single ratchet or star wheels, pawl-levers, and electro magnets by a single line, or by two or more of such ratchet or star wheels, pawl-levers, electro-magnets, and conductors, as the operation in either case is the same.

The speed of the electromotor is controlled by a governor so organized that vertical motion is imparted to a conical hub on the shaft of a centrifugal governor by changes of speed which increases or diminishes the divergence of the governor-arms. An arm bearing against this conical hub regulates the distance of the pole-piece of a pivoted electro-magnet from the periphery of a diamagnetic wheel on the governor-shaft, permitting the pole to move by the action of a spring toward the wheel as the arms of the governor diverge in consequence of an increase of speed, and forcing it away from the wheel as the speed decreases.

The governing electro-magnet is preferably in a shunt-circuit, but may be in the main-line circuit or in a branch thereof, and the intensity of its magnetization will always bear a definite relation to the intensity of magnetization of the motor electro magnets, whatever variation may occur in the strength of the battery, and hence it must follow that the governor can be adjusted to maintain regular speed of the electromotor irrespective of variations in the strength of the current, and that this speed may be diminished or increased by diverting more or less of the current through the coils of the governing electro-magnet or by adjusting its pole at a greater or less distance from its diamagnetic wheel.

On the pawl-levers are placed arms which lock the ratchet-wheels at each step-by-step movement. One of the shafts carries a spacing-wheel, at any division of which the shaft may be stopped and firmly held by the armature-lever of a differential electro-magnet included in double-line circuits, when both circuits are simultaneously closed or broken. The circuits connecting several of these electromotors are so organized that one of the series with conductors alternately in closed and open circuits through suitable keys, a sunflower, electro-magnets, and a battery, may be employed to

operate other similar electromotors and cause a synchronous movement of the electromotors by sending pulsations over the lines connecting the same, to energize the electro-magnets of the driven motors, and by a change of circuits through a suitable switch any motor in the series may be made to operate the others.

All the motors may be arrested simultaneously by a differential electro-magnet in the circuit of both conductors. A double electro-magnet may be arranged in two circuits of a battery to vibrate a single lever acting to move each electromotor, the closed-circuit keys being in electrical connection alternately with the respective branches of this electro-magnet through the segments of a sunflower, the brushes of which alternately close the circuit through said keys. When the circuit is interrupted by the depression of any key, the electromotors in circuit will be arrested.

I will now proceed to describe my invention with reference to the accompanying drawings, in which—

Figure 1. is a side elevation of an electromotor, showing two shafts with two ratchet-wheels on each shaft. Fig. 2 is an end elevation of the same. Fig. 3 is a plan view thereof, showing the lower ratchet-wheels and mechanism below the line $x x$ of Fig. 2. Fig. 4 is a plan view and horizontal section of the electromotor taken below the top plate, showing the upper ratchet-wheels, gear-wheels, governor, and mechanism operating in connection therewith. Fig. 5 is a plan view of the star-wheel and wedge-pallet escapements, showing two shafts geared together by gear-wheels of similar diameter and each carrying two similar star-wheels. Fig. 6 is a plan view of a wedge-pallet escapement consisting of single star-wheels on each of two shafts geared together by gear-wheels of similar diameter and operated by pallets on a single lever vibrating between the star-wheels. Fig. 7 is a theoretical diagrammatic view of the circuits, showing the connection and operation of two electromotors, designated as "driving" and "driven" motors, when the double-line electrical circuits are connected through a sunflower and suitable contact-keys. Fig. 8 is a plan view of a single lever-escapement operated by alternate pulsations over two conductors and driving two star-wheels on separate shafts geared together by gear-wheels of similar diameter; and Fig. 9 is a top or plan view of the balance-wheel, showing also the shaft, slot, and pin connection and a portion of the helicoidal spring.

Referring now to the drawings, in any suitable frame-work consisting of a base, A, posts P P, and cap B, I arrange two vertical shafts, X X', pivoted in bearings x^1 , x^2 , x^3 , and x^4 , and geared together by gear-wheels H H', of similar diameter, secured to the respective shafts X X' to insure equal speed of these shafts. These shafts X X' carry each two ratchet-wheels, d^1 d^2 e^1 e^2 , secured thereto, the number of teeth in these ratchet-wheels being the same.

In Figs. 3 and 4 ten teeth are shown in each wheel; but the number of teeth, of course, it will be readily understood, is immaterial.

The upper ratchets, d^1 d^2 , Figs. 1, 2, 3, and 4, are operated by the combined action of the electro-magnet D, with its armature d , pawl-lever d^3 , pawls d^4 and d^5 , having springs d^6 , back-stops d^7 , through the posts P', trunnions supported in the frame d^8 , and a retracting-spring, d^9 , adjustable by screw d^{11} , passing through the post P into collars d^{15} , and jamnut d^{16} , to retain the adjustment. The lower ratchets, e^1 e^2 , are similarly operated by the electro-magnet E, with its armature e , pawl-lever e^3 , pawls e^4 and e^5 , having springs e^6 , back-stops e^7 , through the posts P', trunnions supported in the frame e^8 , and a retracting-spring, e^9 , adjustable by the screw e^{11} , passing through the post P, with collar e^{15} , and jamnut e^{16} to retain the adjustment.

The pawl-levers d^3 and e^3 carry locking-arms d'' and e'' , which impinge against the ends of the teeth d^{12} d^{13} e^{12} and e^{13} when the pawl-levers are vibrated, as hereinafter more fully explained.

On the shaft X is a double-line pulsator, G, composed of two independent divisions, g^{17} and g^{18} , and having in each part thereof as many metallic contacts g^5 and g^7 in the circuit of the respective conductors as there are teeth in each ratchet-wheel. The contacts g^5 are midway between the contacts g^7 , and the insulations g^6 and g^8 occur in the intervening space between the contact g^5 and that of the contact g^7 . The divisions g^{17} and g^{18} of the pulsator G are insulated from each other and from the contacts g^5 and g^7 , which latter are in electrical connection, respectively, with the metallic collars g^9 and g^{10} . The entire pulsator G is insulated from the shaft X, and from the collars g^{14} and g^{15} . The collars g^{14} and g^{15} are secured to the pulsator G, and, together with it, are loose on the shaft X, and the entire combination is supported loosely on the collar g^{16} , secured to the shaft X. The balance-wheel g^{12} , while loose on the shaft X, is secured to the pulsator G, and the collar g^{11} to the shaft X. The pin g^{19} is secured to the balance-wheel g^{12} , and passes through an aperture in the collar g^{11} , slightly larger than this pin g^{19} , to permit a slight advance of the balance-wheel g^{12} and the pulsator G when the shaft X is arrested. Circuit-springs g^1 and g^2 , attached to a block, g^{20} , of insulating material, respectively bear on the collars g^9 and g^{10} , and springs g^3 and g^4 bear, respectively, on the contacts g^5 and g^7 and insulations g^6 and g^8 .

The portions of the divisions g^{17} and g^{18} immediately above and below the contacts g^5 and g^7 and insulations g^6 and g^8 are made of insulating material. The helicoidal spring g^{16} is secured to the shaft X and to the balance-wheel g^{12} , and is available, if desired, to accelerate the forward movement of the balance-wheel when the shaft X is arrested.

The electro-magnet C C' is wound differentially, the conductors being connected to coils

which pass in opposite directions around the cores of this electro-magnet. The spacing-wheel c is secured to the shaft X, and has as many teeth in it as there are teeth in the four 5 ratchet-wheels, or in all forty teeth, as shown in Fig. 3. The armature c' is secured to the lever c^3 , pivoted at c^5 , and adjustable by the spring c^4 and adjusting-rod c^6 , passing through the split post c^7 . On the lever c^3 is an arm, 10 c^2 , which engages in the teeth of the spacing-wheel c when the electro-magnet C C' is inoperative.

The centrifugal governor K is secured to the shaft k' by the collar k^3 , and causes the conical 15 hub k^2 , which is free, to rise and fall as the governor-balls k^4 diverge or approach each other. The conical hub is prevented from turning on the shaft k' by the pins k^2 , which move freely in the collar k^3 , fixed to the shaft 20 k' . The gear-wheel H³ is loose on the shaft k' and is controlled by a clutching device, L, consisting of the movable clutch l^2 , with pins l^5 and l^6 , moving freely on the collar l^4 , which is secured to the shaft k' . The forked lever l^3 , 25 pivoted near its center, embraces the clutch l^2 in the usual manner by means of a fork and pins engaging in a groove in this clutch, and may be held in position by notches in the arm l^4 , as shown in Fig. 1, and the operation of the 30 parts is such that when the clutch l^2 is raised it disengages from the clutch l^2 , secured to the gear-wheel H³, permitting free movement of this wheel on the shaft k' , whereupon the wheel H³ revolves without turning the shaft k' and 35 the centrifugal governor K; but when the clutch l^2 is engaged with the clutch l^2 on the gear-wheel H³ both the shaft and centrifugal governor are revolved by this wheel.

The double-coil electro-magnet F F' has 40 coils wound in the same direction around its cores. It is supported on trunnions f^{11} pivoted on supports f^9 , and has a projecting arm, f^7 , extending at right angles to its trunnions and secured thereto. The arm f^7 bears on an 45 elastic spring, f^8 , tending to tilt the electro-magnet F F' and cause its pole-piece f^7 to approach the diamagnetic rim f^2 of the wheel secured to the shaft k' . From the pole of this electro-magnet F F' projects a paramagnetic 50 rod, f^{10} , through which passes a distance rod, f^3 , adjustable by a screw, f^6 , and nuts f^4 and f^5 . The rod f^3 is supported also by the forked rod f^{12} , pivoted on trunnions f^{13} , and having a pivoted connection at f^{14} with the distance- 55 rod f^3 .

The object of the forked rod f^{12} is to brace the rod f^3 laterally and at the same time insure 60 parallel motion of the same. The end f^{15} of the distance-rod f^3 bears against the conical hub k^2 , and when the balls of the governor K diverge in consequence of increased speed the conical hub is thereby raised and the distance-rod permits the pole-piece f^7 of the electro- 65 magnet F F' to approach nearer to the rim f^2 . When this electro-magnet is energized, as hereinafter more particularly explained, the effect will be to retard the speed of the shaft k' , and

as the speed is retarded the governor-balls will consequently converge, lowering the hub 70 k^2 and increasing the distance of the pole-piece f^7 from the rim f^2 , thereby diminishing the magnetic attraction between the pole-piece f^7 and the rim f^2 , and permitting an increase of speed of the shaft k' . Further regulation 75 of the speed is also effected by the adjustment of the distance between the pole-piece f^7 and the rim f^2 through the screw f^6 , and by varying the resistance in the circuit by the adjustable resistances R and R'.

The double-line key O has insulated termi- 80 nals o^2 and o^4 , connected by the spring o^5 , and terminals o^1 and o^3 , connected by the spring o^6 . The button o^7 on the insulated bar o^8 is employed to depress the springs and to close the 85 contacts at o^3 and o^4 simultaneously.

The electrical circuits as shown in Fig. 1 will now be described.

The circuit from the positive electrode of the battery Z is by the conductors 50, 51, and 60, to the spring g' of the pulsator G, thence 90 by the hub g^9 and contact g^5 to the spring g^2 , thence by the conductor 61 to the electro-magnet C, through the coils of the electro-magnet C, thence by the conductor 62 to the electro- 95 magnet E, through the coils of the electro-magnet E, thence by the conductors 63 and 59 to the negative electrode of the battery Z. The other conductor, 52, branching from the conductor 51, passes through the spring g^4 , hub 100 g^{10} , contact g^7 , spring g^6 , conductor 53, to the electro-magnet C', through the coils of the electro-magnet C', and by conductors 54 and 55 to the electro-magnet D, through the coils 105 of the electro-magnet D, and by conductors 56, 57, 58, and 59 to the negative electrode of the battery Z. A branch circuit, 70, from the conductor 50 branches by conductors 71 and 72 to the terminals o^1 and o^2 of the double-line 110 key O, the conductor 71 continuing by spring o^5 , contact o^3 , conductors 73 and 74, to a junction with the conductor 53, where it connects with the coils of the electro-magnet C', and the 115 conductor 72 continuing by spring o^6 , contact o^4 , and the conductors 75 and 76, to a junction with the conductor 61, where it connects with the coils of the electro-magnet C. One branch of the double-shunt circuit through the coils of the electro-magnet F F' originates at the 120 connection between the conductors 55 and 64, thence passes by the conductor 64, through the resistance R, to the electro-magnet F, through the coils of the electro-magnet F, conductor 65, to the junction with the conductor 57. The other branch originates at the junction of the 125 conductors 62 and 66. The conductor 66 passing through the resistance R', connects with the coils of the electro-magnet F', thence by the conductor 67 to a junction with the conductor 57 in the main circuit, hereinabove described. When the double-line key O is closed, 130 it is evident that there is a direct path for the current by both conductors through the differential electro-magnet C C', whether the springs g^2 and g^3 bear on contacts or insula-

tions. The current will divide between the electro-magnets D and F and E and F', according to the laws governing shunt-circuits, and the intensity of the current in the electro-magnet F F' may be varied at will by varying the resistances R and R'.

The operation of the devices shown in Figs. 1, 2, and 3 will be explained in the following manner: The ratchet-wheel e^6 is locked by the locking-arm e^{11} impinging against a tooth, e^{12} . The spring g^3 has reached a contact with contact g^7 on the lower division, g^{18} , of the pulsator G. The circuit through the electro-magnets C', E, and F' will therefore be closed through their respective conductors and the electro-magnet C' will attract its armature c' and release the spacing-wheel c . The electro-magnet E will be energized, attracting its armature e and causing the pawl e^2 to engage in a tooth of the ratchet-wheel e^7 , moving this wheel one-fortieth of a revolution to the right, and the ratchet wheel e^6 simultaneously moving in a reverse direction, through the gear-wheels H and H', one-fortieth of a revolution to the left. The pawl e^3 will have moved a space equal to one-fourth of a tooth in the ratchet-wheel e^6 , or one-fortieth of a revolution of the wheel, and will now engage in the tooth e^{17} , while the tooth e^{13} of the ratchet-wheel e^7 will be held by the locking arm e^{11} . The motion of the ratchet-wheel e^7 causes the pulsator G to revolve so as to break the circuit through the electro-magnet E. The pawl-lever e' is consequently moved in the opposite direction by the retracting-spring e^9 and the ratchet-wheels e^6 and e^7 are moved thereby so that they occupy the relative positions to their pawls and locking-arms as shown in Fig. 4 by the positions of the ratchet-wheels d^6 and d^7 and pawls d^2 and d^3 , and as these latter ratchet-wheels have moved synchronously with the ratchet-wheels e^6 and e^7 they will now be in the position shown in Fig. 3 for the ratchet-wheels e^6 and e^7 . A contact, g^5 , on the division g^{17} of the pulsator G will now be made with the spring g^2 , closing the circuit through the electro-magnet D, and the next movement of the ratchet-wheels, as previously described, will break this circuit, while the consecutive movement of the pawl-lever d' , by the action of the spring d^3 , will cause the circuit to be again closed through the electro-magnet E, thus producing a repetition of the movement of the ratchet-wheels e^6 and e^7 , as hereinbefore described. It is evident, therefore, that the shafts will continue to revolve while the battery-circuit is connected. The electromotor may be stopped at will at any quarter division of a ratchet-tooth, or one fortieth, of a revolution, by closing the double-line key O, which closes both circuits simultaneously through the respective coils of the electro-magnet C C', neutralizing the action of the same on the cores and thereby releasing the armature c' and locking the spacing-wheel c by the arm c^2 on the armature-lever c^3 .

The speed of the electromotor may be regu-

lated by the electro-magnetic governor by varying the distance of the pole-piece f' from the diamagnetic rim f^2 , or by varying the strength of the current through the electro-magnet F F' by the interposition of greater or less resistance in R and R', and the governor may be detached by releasing the clutch L from the gear-wheel H³.

The action of the balance-wheel g^{12} causes the pulsator G to advance slightly after the shaft X has been arrested at the termination of each stroke of a ratchet-lever, thus insuring a make of circuit when a pawl-lever, d' or e' , has been drawn back by its spring, or a break of circuit just as the armature d or e strikes the cores of its electro-magnets, or when its lever is arrested by a back-stop, d^3 or e^3 .

In Fig. 7 is shown a theoretical diagrammatic view of the electrical circuits connecting an electromotor, represented in this view on the left of the sheet, and designated as the "driving" electromotor, which is similar in all respects to the electromotor shown in Figs. 1, 2, 3, and 4, with the exception that a double sunflower, T', is substituted for the pulsator G, and in the view to the right thereof is represented a double sunflower, T², substituted for the pulsator G in a precisely similar electromotor, and designated as the "driven" electromotor.

The electro-magnets, shafts, sunflowers, keys, and operative parts of the respective electromotors are designated by the same reference-letters, but with different numerals, in order that the circuits that connect the respective electro-magnets, sunflowers, brushes, and keys of the driving-electromotor, with corresponding parts in the driven electromotor, may be readily traced and the operation of the circuits through the respective electromotors readily understood.

The double sunflowers T' and T² are located with their centers corresponding, respectively, with the center lines of the shafts X and X², on which are double contact-springs t^5 , t^6 , t^{23} , and t^{24} , double collars t^{10} , t^{11} , t^{21} , and t^{22} , insulated from each other and from the shafts X and X², double hubs t^{14} , t^{15} , t^{20} , and t^{20} , insulated from each other and from the shafts X and X², arms t^7 , t^9 , t^{17} , and t^{19} , for each hub, carrying brushes t^{13} , t^{12} , t^{16} , and t^{18} . The upper collars, t^{10} and t^{11} , are respectively in electrical connection with the upper hubs, t^{14} and t^{20} , and the lower collars, t^{21} and t^{22} , with the lower hubs, t^{15} and t^{20} , the hubs being in electrical connection with the divisions of the sunflower through their arms t^7 , t^9 , t^{17} , and t^{19} and brushes t^{13} , t^{12} , t^{16} , and t^{18} . The sunflowers are shown in plan view at T³, consisting of two annular rings each having forty metallic segments which are insulated from one another.

Two key-boards are provided, Fig. 7, with keys similar to V V², for closing a circuit normally open through the springs $v v'$ and $v' v^3$, and with keys V' V³ for breaking the circuit normally closed by the springs $v^2 v^3$ and $v^3 v^{10}$. The springs $v v^2$ and $v' v^3$ are respectively in

contact with the metallic bars v^6 v^5 and v^{11} v^{12} , while the springs v' v^3 and v^8 v^{10} are insulated therefrom by the insulating material v^{14} v^{13} and v^{16} v^{17} . The open-circuit springs v' and v^8 are
 5 connected by the conductors 15 and 34 to the outer segments, t^{25} , of the sunflowers T' and T², respectively, and the closed-circuit springs v^3 and v^{10} are connected by the conductors 5 and 33 to the consecutive outer segments, t^{25} , of the
 10 respective sunflowers. The conductors 31 and 32 run from the inner segments, t^{25} , of the sunflower T' to closed and open circuit springs similar to v^3 and v' , (not shown,) and the conductors 35 and 36 from the inner segments of
 15 the sunflower T² to closed and open circuit springs, respectively, similar to v^{10} and v^8 , but also not shown, the entire key-board containing twenty keys for open circuits and twenty
 20 keys for closed circuits when the spacing-wheels c and c' have forty divisions and the ratchet-wheels d^7 e^7 and d^{15} e^{15} have each ten teeth; but these numbers may of course be varied indefinitely as the number of teeth in the
 25 ratchet-wheels are varied.

The circuit of the battery Z is from earth, by the conductor 1, to the negative electrode, from the positive electrode, by the conductor 2, to the switch S, thence to the contact s , and by the conductors 3 and 4 to the insulated bar
 30 v^5 , connecting all the springs v^2 , and by the branch conductor 14 to the insulated bar v^6 , connecting all the springs v . The circuit is then through the springs v^2 and v^3 , the conductor 5 to the outer segment, t^{25} , of the sunflower T'.
 35 From the sunflower T' the circuit is by the brush t^{13} , arm t^5 , hub t^{15} , collar t^{11} , spring t^6 , conductor 6 to the electro-magnet D, conductors 7, 8, and 9 to the electro-magnet C, conductor 10 to the electro-magnet C², conductor
 40 11 to the electro-magnet D', thence by conductor 12 to the contact s' , switch S', and conductor 13 to earth. The other conductor, 14, in connection with the open-circuit keys, is from the spring v to the spring v' when closed,
 45 thence by the conductor 15 to the outer segment of the sunflower T', whence the course is by the line above described.

The circuit from the keys not shown but corresponding to V and V' by the conductors
 50 31 and 32, and the inner segments, t^{25} , of the sunflower T', is by brush t^{12} , arm t^6 , hub t^{14} , collar t^{10} , spring t^7 , conductor 16 to the electro-magnet E, conductor 17 to the electro-magnet C', conductor 18 to the electro-magnet C², by
 55 the conductor 19 to the electro-magnet E', and by the conductor 20 to the contact s^5 , thence by the switch S' and the conductor 13 to earth.

Double-line keys O and O', with springs o^5 o^6 and o^8 o^9 , and rear contacts, o' o^2 and o^{12} o^{13} , and front contacts, o^7 o^4 and o^{10} o^{11} , are inserted in branch conductors 21, 22, 23, and 24, and
 60 40, 41, 42, and 43, for the purpose of closing this circuit simultaneously through the electro-magnets D, E, D', E', C, C', C², and C³ directly from the battery by the conductor 2, switch S, contact s' , conductors 3 and 21 when the double-line key O is in circuit.

The double-coil magnet F' F' in Fig. 7, controlling the governor, as shown in Fig. 1, employed to regulate the speed of the driving-
 70 electromotor is placed in shunt-circuits 25, 26, 27, 28, 29, and 30, in which are included resistances R and R' and plugs Q and Q', and the double-coil electro-magnet F² F³ is placed
 75 in the shunt circuits 44, 45, 46, 47, 48, and 49, in which are included the resistances R⁴ and R⁵ and plugs Q² and Q³. The resistances are employed to vary the strength of the current through the shunt-circuits and the plugs to
 80 cut out the electro-magnet F² F³ of the driven electromotor, the speed of which is controlled by the driving-electromotor.

The operation of the two electromotors connected by conductors in the circuit of the battery Z, as illustrated in Fig. 7, will now be
 85 explained.

When a closed-circuit key, V', is depressed, thereby interrupting one circuit of the battery Z at the contact-springs v^2 and v^3 , through the electro-magnets D and D' and C and C², all the
 90 electro-magnets of the driving and driven electromotors will be in open circuits, and the electromotors will of course be arrested. Upon releasing the key V' the circuit will be closed through the electro-magnets D and D'
 95 and C and C², causing, as previously explained, a rotation of the shaft X through one-fortieth of a revolution, and causing the shaft X² of the driven electromotor to rotate similarly and synchronously. This movement of the
 100 shaft X will cause the brush t^{13} , in electrical connection with an outer segment of the sunflower T', conductors 5 and 6, and the circuit hereinbefore described, to move forward one
 105 division of the sunflower, and consequently to make contact with an outer segment in the sunflower in the circuit previously described, connected to the open-circuit springs v and v' . The electro-magnets D and D' will thereupon
 110 be demagnetized and the shafts of the respective electromotors will be rotated through one-fortieth of a revolution, as fully explained in the description of the electromotor, as shown in detail in Figs. 1, 2, 3, and 4. This movement
 115 will cause the brush t^{12} to make contact with an inner segment of the sunflower T', in electrical connection through the conductor 31, with closed-circuit springs like v^2 and v^3 , and by conductor 16, and the circuit previously described,
 120 through the electro-magnets E E' C' C². The electro-magnets E and E' will be energized and the shafts X and X² will again be advanced one-fortieth of a revolution and cause the brush t^{12} to make contact, through the conductor 32, with open-circuit springs
 125 like v and v' , and by the conductor 16, and circuit previously described, through the electro-magnets E and E', producing another rotatory movement, which causes the brush t^{12} to close the circuit through the electro-magnets D and
 130 D', causing a repetition of the movements hereinbefore described, so that continuous step-by-step rotatory motion of the shafts will continue until interrupted, as will be herein-

after explained. The pulsations in the respective circuits through the differential electro-magnets C C' and C² C³ charge these electro-magnets, or cause their armatures to be rapidly vibrated without arresting the spacing-wheels *c* and *c'*. If a key, V', is depressed, a closed circuit through a segment of the sunflower T' will be broken, and the brush t¹³ will make contact with the two consecutive broken-circuit segments in succession, which will arrest the motion of the driving-electromotor, and the same result will follow if a key, V, is depressed. If the double-line key O be closed, thereby closing the circuits simultaneously around the keys and sunflower of the driving-electromotor, and through all the electro-magnets in both circuits, the differential electro-magnets C C' and C² C³ will be rendered inert, and the electromotors will be simultaneously arrested by the action of these electro-magnets, as previously explained. Alternate pulsations over the respective main conductors pass through the shunt-circuits 28, 29, and 30, and 25, 26, and 27, energizing alternately the electro-magnet F F' of the driving-electromotor. The shunt-circuits 44, 45, and 46, and 47, 48, and 49 being interrupted by the removal of the plugs Q² and Q³ in the shunt-circuit of the driven electromotor will render inert the electro-magnet F² F³. The speed of the driving-electromotor will be controlled by the electro-magnet F F', as described. The switch S being turned to the contacts *s'* and *s²*, and the switch S' being turned to the contact *s³*, and the plugs inserted at Q² Q³ and removed at Q and Q', the springs *v⁷* *v⁸* and *v¹⁰*, the sunflower T², the double-line key O, and the electro-magnet F² F³ will be in the circuit of the battery Z, and the right-hand electromotor in Fig. 7 becoming, in this instance, the driving electromotor, while the corresponding parts in the left-hand electromotor of this figure will be out of circuit, and the action of the respective electromotors will be reversed. The electro-magnets of both electromotors will then respond to pulsations through the sunflower T², and the circuits may be closed or interrupted by operating the keys V² and V³ and the double-line key O'. The escapement N (shown in Fig. 5) consists of two star-wheels, *n²* and *n¹²*, with alternate teeth omitted, the wheels being secured to a shaft, *n*, and the two star-wheels *n³* and *n¹³*, with consecutive teeth, secured to a shaft, *n'*. The shafts *n* and *n'* are geared together by wheels N² and N³ of similar diameter. The electro-magnet N' and a corresponding electro-magnet for the lever *n¹⁵* (not shown in Fig. 5) operate alternately by alternate pulsations over two conductors, precisely as described for the ratchet-wheels in Figs. 1 and 2. The pallet *n¹⁹* first strikes in the tooth *n²¹*, when the electro-magnet for the lever *n¹⁵* is energized, driving the star-wheels *n¹³* and *n³* one thirty-second of a revolution to the right. When this electro-magnet is demagnetized, the retracting-spring of the lever *n¹⁵* (not shown)

drives the pallet *n¹⁹* on the outer side of the tooth *n²²*, and the star-wheels on the shafts *n* and *n'* make one thirty-second of a revolution. They are now in the position shown for the star-wheels *n²* and *n³*. The star-wheels *n²* and *n³* will have moved two consecutive steps, equal in the aggregate to one-sixteenth of a revolution, and will now occupy the same relative positions respecting their pallets as is shown for the star-wheels *n¹²* and *n¹³* and the pallets *n¹⁹* and *n²⁰*. The electro-magnet N' is next energized, driving the wheels *n²* and *n³* each one thirty-second of a revolution by wedging forward the tooth *n²⁵*, and when this electro-magnet is demagnetized the lever *n⁷* is driven by the retracting-spring *n¹⁰* in the opposite direction, the pallet *n²⁴* now striking on the near side of the tooth *n²⁰* of the star-wheel *n²*. No locking-bar is requisite in this arrangement, since the pallets serve to lock the star-wheels *n²* and *n³*, and the star-wheels *n²* and *n¹³* are alternately locked, as shown, in the position for the star-wheel *n¹²* and the pallet *n¹⁹* in Fig. 5.

In Fig. 6 is shown an arrangement, M, of two shafts geared together by wheels of similar diameter, with two single star-wheels, *m²* and *m³*, secured respectively to their shafts *m* and *m'*, and operated by a single electro-magnet, M', and retracting-spring *m¹⁰*, operating a single pallet-lever, *m⁷*.

The alternating movements of the pallets when the electro-magnet M' is energized by single-line pulsations cause a progressive step-by-step movement of the star-wheels *m²* and *m³* in opposite directions, each make of circuit in this case causing a movement of one thirty-second of a revolution, and each break of circuit a similar movement.

In Fig. 8 the single star-wheels *u'* and *u²* are secured to separate shafts, *u⁵* and *u⁶*, geared together by wheels U' U² of equal diameter. The pallet-lever *u³* is pivoted on trunnions at *u¹⁶*, and the armatures *u⁴* and *u⁵* of the separate electro-magnets U³ and U⁴ are secured to right-angular extensions *u¹⁷* and *u¹⁸* of the pallet-lever *u³*. The electro-magnets U³ U⁴ being alternately energized by pulsations over the separate line-conductors 62, 63, 55, and 56 of Fig. 1 will cause vibrations of the pallet-lever *u³*, producing consecutive step-by-step movements of the star-wheels *u'* and *u²*. Such a combination may be evidently substituted in the double-line systems illustrated in Figs. 1, 2, 3, 4, and 7 by omitting the two electro-magnets D and E, with their corresponding ratchet-wheels, *d⁶* *d⁷* and *e⁶* *e⁷* and the armature-levers *d⁷* and *e⁷*, and introducing, instead of the single pallet-lever, star-wheels and a double electro-magnet, as shown in Fig. 8. The conductors 55 and 56 will then energize one branch of the electro-magnet U³, and the conductors 62 and 63 the other branch of the electro-magnet U⁴.

The pulsator G will have contacts *g³* in one division, *g¹⁷*, immediately following the contacts *g⁷* in the other division, *g¹⁸*, insulations *g⁶* in one division alternating with the contacts *g⁷* in

the other division, so as to cause the circuit through one conductor to be closed just as the circuit is interrupted in the other conductor.

It is obvious, without further illustration or explanation, that the star-wheels n^2 n^3 and n^{12} n^{13} (shown in Fig. 5) may be substituted for the ratchet-wheels d^6 d^7 and e^6 e^7 , in Figs. 1, 2, 3, and 4, and for the ratchet-wheels d^7 e^7 and d^{15} e^{15} in Fig. 7, and the operation with either form will be the same when arranged in double-line circuits.

If the star-wheels u^1 and u^2 in Fig. 8 be substituted in Figs. 1, 2, 3, and 4, with the electromagnets U^3 and U^4 introduced into the double-line circuits of Fig. 7, instead of the electromagnets D , E , D' , and E' , the operation will obviously be the same, with this exception that all the active segments of the sunflower will be connected to closed circuit-springs, instead of alternately open and closed circuit-springs v^1 v^3 v^8 v^{10} , as shown. A break of circuit by depressing any key will in this case stop the electromotors, and the releasing of the key will again cause their rotation.

The star-wheels m^2 and m^3 in Fig. 6 will operate the shafts X and X' of Figs. 1, 2, 3, and 4, if connected in one of the circuits, as shown, if there are sixteen contacts g^5 , and sixteen insulations g^6 , in one division, g^{17} , of the pulsator G , omitting the other division, g^{18} , and substituting star-wheels m^2 and m^3 , pallet-lever m^7 , pallets m^5 and m^6 of Fig. 6, for all the ratchet-wheels, levers, and pawls, as shown in Figs. 1, 2, 3, and 4.

To operate the shafts X and X^2 in Fig. 7 with the star-wheels m^2 and m^3 , pallets m^5 and m^6 , and pallet-lever m^7 , actuated by a single electro-magnet, M' , and spring m^{10} , it is only necessary to substitute these star-wheels for the ratchet-wheels d^7 e^7 and d^{15} e^{15} , (shown therein,) and the electro-magnet M' for the electro-magnets D and D' , omitting the electro-magnets E , E' , C , C' , C^2 , and C^3 , making the electro-magnets F F' in one section. The double-line keys O O' and the entire conductor connecting the brush t^{12} and inner segments of the sunflower through the conductors 31 and 32, and the contact-springs similar to v and v' , must in this case be omitted. The outer ring of segments, t^{25} , must be connected alternately by the conductors 5 and 15 to the circuit-springs v^3 and v^7 , the entire number of segments being equal to twice the number of teeth in one star-wheel m^2 or m^3 . Consecutive makes and breaks of circuit will then cause single-line pulsations to pass through the electro-magnet M' , substituted for the electro-magnets D and D' , to operate the pallet-lever m^7 and the star-wheels m^2 and m^3 , and thus to produce a synchronous movement of the shafts X and X^2 .

The devices for performing certain functions hereinabove alluded to will be readily understood by those skilled in electrical science, and hence it has not been deemed necessary to illustrate them, because it would be merely to show electro-magnets and devices substan-

tially such as have been already fully shown and described. I desire it to be distinctly understood, however, that I do not limit myself to operating the electromotors by double-line conductors, as it will be obvious that they may be operated as well by a single electro-magnet responding to pulsations over a single conductor as with two electro-magnets responding to double-line conductors by omitting one pair of ratchet or star wheels and constructing the other pair with double the number of teeth.

Having thus described the nature and objects of my invention, what I claim as new, and desire to secure by Letters Patent, is—

1. A step-by-step electromotor consisting of two shafts geared together by wheels of similar diameter, carrying two ratchet or star wheels opposite to one another on each of said shafts, and actuated by two levers carrying pawls or pallets vibrated alternately between said ratchet or star wheels by two electro-magnets in the circuit of a battery, substantially as and for the purposes set forth.

2. A step-by-step electromotor consisting of two shafts geared together by wheels of similar diameter, and each carrying two ratchet-wheels, the wheels on one shaft being opposite to those on the other shaft, the teeth in the respective ratchet-wheels alternating with each other, two levers vibrating alternately between the respective ratchet-wheels, carrying pawls, locking-arms, armatures, and retracting-springs, two electro-magnets in the circuit of a battery for vibrating said armatures and levers, said electro-magnets responding to alternate and successive makes and breaks of circuit, and a circuit-interrupting device, substantially as and for the purposes set forth.

3. A step-by-step electromotor consisting of two shafts geared together by wheels of similar diameter and moving synchronously, and each carrying two star-wheels, the star-wheels on one shaft being opposite to those on the other and having every alternate tooth omitted, levers carrying wedge-pallets, armatures, and retracting-springs, the wedge-pallets vibrating between the star-wheels and engaging alternately in opposite star-wheels, one lever being inactive while the other is in action, two electro-magnets in the circuit of a battery for vibrating the armatures and levers, said electro-magnets responding to alternate and successive makes and breaks of the circuit, and electrical devices, substantially as described, for interrupting the circuit, substantially as and for the purposes set forth.

4. In a step-by-step electromotor, the combination of an electro-magnetic governor consisting of an electro-magnet with its pole-piece, said electro-magnet energized by pulsations through a battery-circuit of the electromotor, a shaft and a diamagnetic rim secured thereto, a centrifugal governor secured to the same shaft, a conical hub sliding freely on said shaft and actuated through the convergence and di-

vergence of the governor arms, a distance-rod secured to the pole-piece of the electro-magnet and resting loosely against said conical hub, and a spring acting to press the pole-piece toward the diamagnetic rim, substantially as and for the purposes set forth.

5. The combination of a balance-wheel secured to a pulsator loose on its shaft, a collar secured to said shaft, and a pin in said balance-wheel moving freely in an aperture in said collar, substantially as and for the purposes described.

6. The combination of a pulsator loose on a shaft held in position longitudinally by a fixed collar, a balance-wheel attached to said pulsator, a collar at the opposite extremity of said pulsator secured to said shaft, a pin in said balance-wheel moving freely in an aperture in said collar, and a helicoidal spring attached at one end to said shaft and at the other end to the balance-wheel, substantially as and for the purposes set forth.

7. The combination of a battery and two main conductors, two shafts geared together by wheels of similar diameter, and each carrying two ratchet-wheels, the teeth in one pair alternating with the teeth in the other pair, and an electro-magnet, with its armature, pawl-lever, pawls, locking-arms, and retracting-spring, for each pair of ratchet-wheels, the pawl-lever of each pair of wheels being vibrated alternately and successively by said electro-magnet energized by pulsations over the respective conductors, substantially as and for the purposes described.

8. The combination of a battery and two main conductors, two shafts geared together by wheels of similar diameter, and each carrying two star-wheels, the star-wheels on one shaft being opposite to those on the other, and having every alternate tooth omitted, levers carrying wedge-pallets, armatures, and retracting-springs, the wedge-pallets vibrating between said star-wheels and engaging alternately in opposite star-wheels, two electro-magnets in the circuit of said battery, a differential electro-magnet in the same circuits, and a spacing-wheel on one of said shafts locked by the armature-lever of said differential electro-magnet, substantially as and for the purposes set forth.

9. The combination of a battery and two main conductors, two shafts geared together by wheels of similar diameter moving synchronously and each carrying two ratchet-wheels, the teeth in one pair alternating with the teeth in the other pair, two electro-magnets, with their armatures, pawl-levers, retracting-springs, and pawls, the pawl-levers vibrated alternately between the respective ratchet-wheels by said electro-magnets in the circuits of said battery, a differential electro-magnet in the same circuits, a spacing-wheel on one of said shafts locked by the armature-lever of said differential electro-magnet, a divided-coil electro-magnet in the same circuits having an

extended pole-piece, and a diamagnetic rim secured to a shaft geared to the ratchet-shafts, substantially as and for the purposes set forth.

10. The combination of a battery and two main conductors, two shafts geared together by wheels of similar diameter and each carrying two ratchet-wheels, the teeth in one pair alternating with the teeth in the other pair, two electro-magnets, with their armatures, pawl-levers, retracting-springs, and pawls, the pawl-levers being vibrated alternately and successively by alternate pulsations over the respective conductors, a divided-coil electro-magnet in the circuits of said conductors, a diamagnetic rim controlled by said divided-coil electro-magnet, a centrifugal governor on a shaft geared to a ratchet-shaft, a differential electro-magnet, and a spacing-wheel on one of said shafts locked by the armature-lever of said differential electro-magnet, with its coils in both conductors energized by simultaneous pulsations, substantially as and for the purposes set forth.

11. In a step-by-step electromotor, two shafts geared together by wheels of similar diameter and each carrying two ratchet-wheels, two electro-magnets, with their armatures, pawl-levers, retracting-springs, and pawls, the pawl-levers vibrated alternately and successively by alternate pulsations over the respective conductors, in combination with a battery and two main conductors, a differential electro-magnet in the circuits of the conductors, and a spacing-wheel on one of said shafts locked by the armature-lever of said differential electro-magnet, substantially as and for the purposes described.

12. In a step-by-step electromotor, two shafts geared together by wheels of similar diameter and each carrying two ratchet-wheels, two electro-magnets, with their armatures, pawl-levers, retracting-springs, and pawls, the pawl-levers vibrated alternately and successively by said electro-magnets energized by alternate pulsations over the respective conductors, in combination with a battery and two main conductors, a differential electro-magnet in the same circuits, a spacing-wheel on one of said shafts locked by the armature-lever of said differential electro-magnet, a diamagnetic rim secured to a shaft geared to the ratchet-shaft, and a divided-coil electro-magnet in the circuits of said battery, having an extended pole-piece controlling said diamagnetic rim, substantially as and for the purposes set forth.

13. A step-by-step electromotor consisting of two shafts geared together by wheels of similar diameter and each carrying two star-wheels, two electro-magnets, with their armatures, wedge-pallets, and retracting-springs for actuating said star-wheels, in combination with a battery, two main conductors, a differential electro-magnet, and a spacing-wheel on one of said shafts locked by the armature-lever of said differential electro-magnet, with coils in both

conductors, a governor electro-magnet in the same circuits, having an extended pole-piece, a diamagnetic rim secured to a shaft geared to a star-wheel shaft and controlled by said divided-coil electro-magnet, and a circuit-interrupting device, substantially as and for the purposes set forth.

14. In combination with a step-by-step electromotor consisting of two shafts geared together by wheels of similar diameter and each carrying two star-wheels, two electro-magnets, with their armatures, wedge-pallets, and retracting-springs for actuating said star-wheels, a battery and two main conductors, a differential electro-magnet in the circuits of said battery, a spacing-wheel secured to one of the star-wheel shafts and locked by the armature-lever of said differential electro-magnet, a divided-coil electro-magnet in the same circuits, the core of which electro-magnet has an extended pole-piece, a diamagnetic rim secured to a shaft geared to one of the star-wheel shafts, a circuit-interrupting device, and a double-line key in said circuits to arrest said electromotor, substantially as and for the purposes set forth.

15. In combination with a step-by-step electromotor consisting of two shafts geared together by wheels of similar diameter moving synchronously, and each carrying two star-wheels, two electro-magnets, with their armatures, wedge-pallets, and retracting-springs for actuating said star-wheels, a battery and two main conductors, a differential electro-magnet in the same circuits, a spacing-wheel locked by the armature-lever of said differential electro-magnet, a circuit-interrupting device, resistances and plugs in shunt-circuits to the main conductors, and a double-line key in said circuits to arrest said electromotor, substantially as and for the purposes set forth.

16. The combination of a battery, two main conductors, two electro-magnets, one in each of the circuits of said battery, armatures, pallet-levers, and pallets for the respective electro-magnets, star-wheels on two synchronously-moving shafts in each of two electromotors operated by said levers provided with pallets, a differential electro-magnet with its armature-lever, and arm, a spacing-wheel secured to one of said shafts and locked by the armature-lever of said differential electro-magnet, with its coils in both conductors energized by simultaneous pulsations, a divided-coil electro-magnet in the same circuits, having an extended pole-piece, a diamagnetic rim secured to a shaft geared to one of the star-wheel shafts, a circuit-interrupter, resistances, and plugs in shunt-circuits to the main conductors, and a double-line key in the circuits of both conductors, substantially as and for the purposes set forth.

17. The combination, with a step-by-step electromotor, of a centrifugal governor secured to a shaft, a conical hub sliding freely on said shaft, a collar secured to said shaft,

and pins secured to said hub and sliding freely in said collar, a gear-wheel secured to said shaft, and clutch mechanism operating substantially as described, for the purposes set forth.

18. The combination, in a step-by-step electromotor, of a shaft carrying a gear-wheel, a clutch secured thereto and moving freely on said shaft, a movable clutch loose on said shaft, a fixed collar on said shaft, pins attached to the movable clutch and moving freely in said collar, a bifurcated lever held in position by an arm, a conical hub, and a centrifugal governor for controlling its movement, substantially as and for the purposes set forth.

19. The combination, in a step-by-step electromotor, of a conical hub carried by the shaft of a centrifugal governor, a centrifugal governor for controlling the movement of said conical hub, a divided-coil electro-magnet, with a pole-piece held on trunnions pivoted to supports, a projecting arm secured to the trunnions, an elastic spring abutting against the projecting arm, and a diamagnetic rim secured to the governor-shaft, substantially as and for the purposes set forth.

20. The combination, in a step-by-step electromotor, of two shafts geared together by wheels of similar diameter, ratchet or star wheels thereon, a spacing-wheel secured to one of the shafts, a circuit-interrupting device secured to one of said shafts, a balance-wheel with a collar thereon, and a helicoidal spring, all arranged substantially as and for the purposes described.

21. A step-by-step electromotor consisting of two shafts geared together by wheels of similar diameter and carrying ratchet or star wheels actuated alternately by levers carrying pawls or pallets vibrated between said wheels by two electro-magnets in the circuit of a battery, in combination with a battery, two main conductors, a circuit-interrupting device, a differential electro-magnet in the same circuits, and a spacing-wheel on one of said shafts locked by the armature-lever of said differential electro-magnet, substantially as and for the purposes set forth.

22. In a step-by-step electromotor, two shafts geared together by wheels of similar diameter and carrying ratchet or star wheels actuated alternately by levers carrying pawls or pallets vibrated between said wheels by two electro-magnets in the circuits of a battery, in combination with a battery and two main conductors, a circuit-interrupting device, a differential electro-magnet in the same circuits, a spacing-wheel on one of said shafts locked by the armature-lever of said differential electro-magnet, a double-line key in the circuits of both conductors to arrest said electromotor, and resistances and plugs in shunt-circuits to both conductors, substantially as and for the purposes set forth.

23. In two step-by-step electromotors of a battery and two main conductors, the electro-

magnets of which are in the circuits of said battery, in combination with electrical devices, substantially as described, for interrupting the circuits, differential and divided-coil electro-
5 magnets in the circuits of the respective conductors, to lock the spacing-wheel and govern said electromotors, a double-line key in the same circuits to arrest said electromotors, and resistances and plugs in said circuits, substantially as and for the purposes set forth.
1c

In witness that I claim the foregoing as my invention I have hereunto set my signature, this 11th day of March, A. D. 1886, in the presence of two subscribing witnesses.

JACOB H. LINVILLE.

Witnesses:

ANDREW ZANE,
THOS. M. SMITH.