

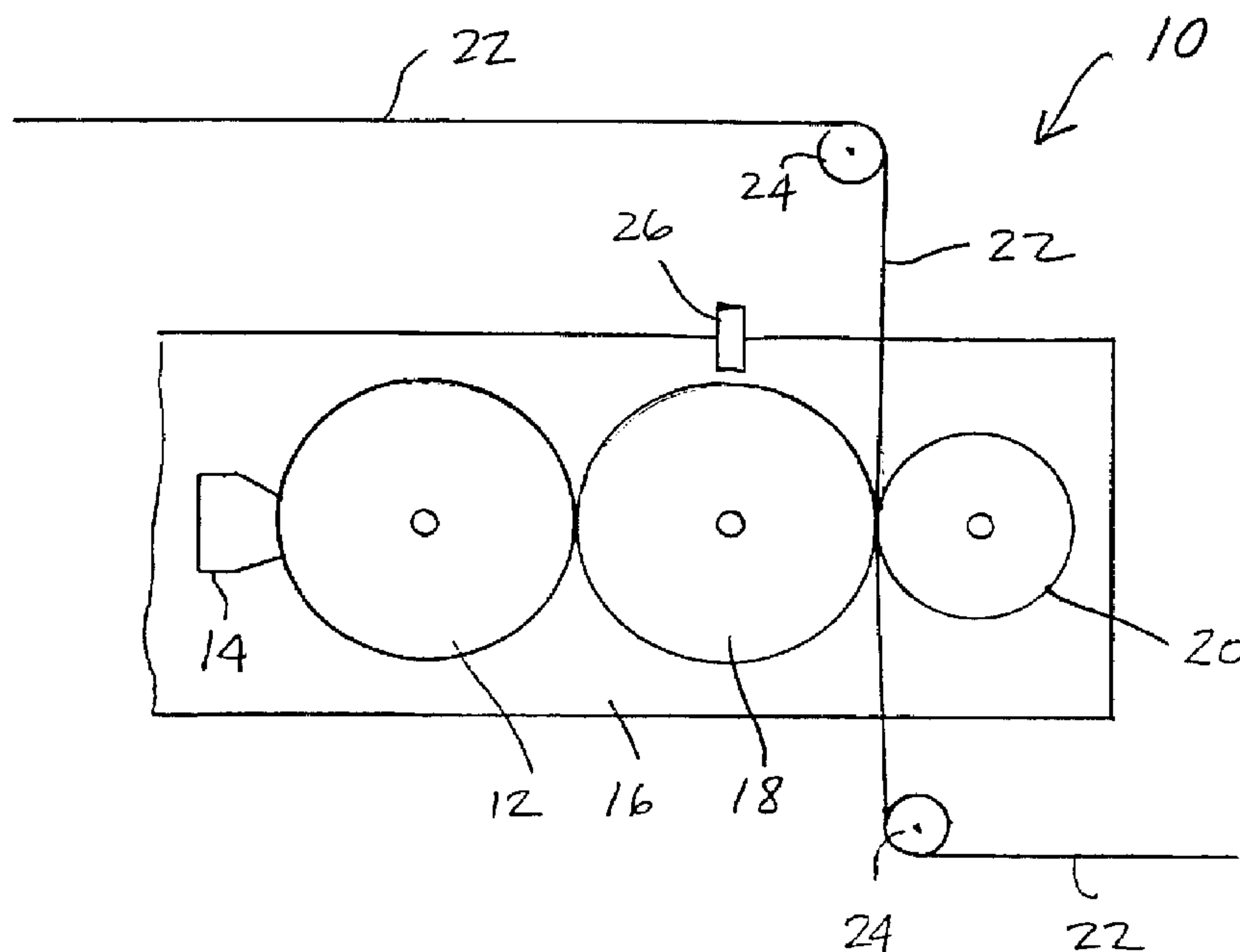

(72) SILER, STEVEN J., US
(72) KLEIN, DAVID M., US
(71) HURLETRON INCORPORATED, US
(51) Int.Cl.⁷ B41F 5/24
(30) 1999/05/12 (09/310,259) US
(54) **APPAREIL D'IMPRESSION FLEXOGRAPHIQUE**
(54) **FLEXOGRAPHIC PRINTING APPARATUS**



(57) A flexographic printing apparatus for printing a moving web is provided with a rotatable ink roller, a roller support that rotatably supports the ink roller, an ink source associated with the ink roller which provides ink for the ink roller, a rotatable printing roller associated with the ink roller, and a printing plate disposed on the printing roller that makes physical contact with the ink roller so that ink is transferred from the ink roller to the printing plate as the ink roller and the printing roller rotate. The printing apparatus also has a rotatable backing roller disposed adjacent the printing roller so that the moving web on which ink is to be applied passes between the backing roller and the printing plate as the backing roller and the printing roller rotate so that a printed image is applied to the web. The apparatus also has a charge applicator that causes an electric charge to be applied to the semi-conductive printing plate.

FLEXOGRAPHIC PRINTING APPARATUS

Abstract of the Disclosure

5 A flexographic printing apparatus for printing a moving
web is provided with a rotatable ink roller, a roller support
that rotatably supports the ink roller, an ink source
associated with the ink roller which provides ink for the ink
roller, a rotatable printing roller associated with the ink
roller, and a printing plate disposed on the printing roller
10 that makes physical contact with the ink roller so that ink is
transferred from the ink roller to the printing plate as the
ink roller and the printing roller rotate. The printing
apparatus also has a rotatable backing roller disposed adjacent
the printing roller so that the moving web on which ink is to
15 be applied passes between the backing roller and the printing
plate as the backing roller and the printing roller rotate so
that a printed image is applied to the web. The apparatus also
has a charge applicator that causes an electric charge to be
applied to the semi-conductive printing plate.

FLEXOGRAPHIC PRINTING APPARATUS

Background of the Invention

The present invention is directed to a flexographic
5 printing apparatus, and more particularly to a flexographic
printing apparatus having an electric charging unit to enhance
print quality.

A conventional flexographic printing press is typically
provided with a plurality of printing stations, each of which
10 prints a moving web with an image in a respective color. Each
of the printing stations is provided with a rotating
cylindrical ink roller, also referred to as an "anilox" roller,
having a regular pattern of minute recesses or ink cells formed
therein. Ink is applied to the ink roller by submerging at
15 least a portion of the ink roller in an ink reservoir, or by
applying ink to a portion of the ink roller via an ink
applicator.

A flexographic press has a rotating cylindrical printing
roller disposed adjacent the ink roller. The printing roller
20 has a printing plate mounted thereon. The printing plate may
be held in place on the printing roller by an adhesive layer,
such as adhesive tape, disposed between the printing plate and
the printing roller. The printing plate is composed of a
photosensitive material that is subjected to a photo-etching
25 process to form raised portions on the printing plate which
correspond to a desired image to be printed. The printing
roller is disposed adjacent the ink roller so that ink is
transferred from the ink cells in the ink roller to the raised
areas on the printing plate.

30 U.S. Patent No. 4,697,514 to George, et al. discloses a
gravure printing apparatus having a gravure cylinder that is

1.5 megohms per cubic centimeter. The printing layer may be a photo-sensitive polymer doped with conductive particles, and may have a resistivity in the range between about 100 thousand ohms per cubic centimeter and about one megohm per cubic centimeter. The charge applicator may be provided in the form of an elongate charge bar having a plurality of charging electrodes spaced from the printing roller. Alternatively, the charge applicator may make direct physical contact with a portion of the printing plate or the roller on which the printing plate is supported.

The printing apparatus may also have an insulating layer disposed between a semi-conductive printing layer and the printing roller. The insulating layer may have a resistivity of greater than about two megohms per cubic centimeter. The insulating layer may be provided in the form of an adhesive layer disposed between the printing layer and the printing roller.

The printing apparatus may also have a conductive layer disposed adjacent the semi-conductive printing layer, the conductive layer having a resistivity lower than about 50 thousand ohms per cubic centimeter, and a high voltage may be applied directly to the conductive layer in order to impart an electric charge to the semi-conductive printing layer.

The invention is also directed to a printing structure for a flexographic printing apparatus having a rotatable ink roller, a roller support that rotatably supports the ink roller, an ink source associated with the ink roller which provides ink to be applied to the ink roller, a rotatable printing roller associated with the ink roller, and a rotatable backing roller disposed adjacent the printing roller.

The printing structure has a semi-conductive printing layer adapted to be disposed on a printing roller. The semi-conductive printing layer is composed of a photo-sensitive polymer material having a resistivity in the range between
5 about 50 thousand ohms per cubic centimeter and about 1.5 megohms per cubic centimeter. The semi-conductive printing layer has an image-forming surface having a plurality of raised areas corresponding to an image to be printed.

The semi-conductive printing layer may have a thickness
10 of less than about one-fourth of an inch, and the semi-conductive printing layer may have a resistivity in the range between about 100 thousand ohms per cubic centimeter and about one megohm per cubic centimeter. The resistivity of the semi-conductive printing layer may be due to the presence of
15 conductive particles therein. The printing structure may have an insulating layer disposed adjacent the semi-conductive printing layer, with the insulating layer having a resistivity of greater than about 100 megohms per cubic centimeter. The printing structure may also have a conductive layer disposed
20 adjacent the semi-conductive printing layer, with the conductive layer having a resistivity lower than about 50 thousand ohms per cubic centimeter.

The features and advantages of the invention will be apparent to those of ordinary skill in the art in view of the
25 detailed description of the preferred embodiment, which is made with reference to the drawings, a brief description of which is provided below.

Brief Description of the Drawings

30 Fig. 1 is a side view of one embodiment of a flexographic printing apparatus in accordance with the invention;

- 5 -

Fig. 2 is a side view of a portion of an embodiment of a printing plate used in the flexographic printing apparatus;

Fig. 3 is a side view of a portion of an ink roller of the flexographic printing apparatus;

5 Fig. 4 illustrates a portion of a charge bar disposed adjacent a portion of a printing roller;

Fig. 5 illustrates a brush that is applying an electric charge to a portion of the printing roller;

10 Fig. 6 illustrates a first embodiment of a printing roller usable with the flexographic printing apparatus of Fig. 1;

Fig. 7 illustrates a second embodiment of a printing roller usable with the flexographic printing apparatus of Fig. 1;

15 Fig. 8 illustrates a third embodiment of a printing roller usable with the flexographic printing apparatus of Fig. 1;

Fig. 9 illustrates a fourth embodiment of a printing roller usable with the flexographic printing apparatus of Fig. 1; and

20 Fig. 10 is a side view of a portion of an alternative embodiment of a printing plate used in the flexographic printing apparatus.

Detailed Description of the Preferred Embodiments

25 Fig. 1 illustrates an embodiment of a flexographic printing apparatus 10 in accordance with the invention. Referring to Fig. 1, the printing apparatus 10 has a cylindrical ink roller 12 and an ink applicator 14 that applies ink to the ink roller 12. The ink applicator 14 may be, for example, a chambered doctor blade or other conventional ink
30 applying device. The ink roller 12 is rotatably supported by a support frame 16 so that the ink roller 12 is in contact with

- 6 -

a cylindrical printing roller 18. The support frame 16 rotatably supports the printing roller 18 adjacent a cylindrical backing roller 20. An elongate web 22, composed of paper for example, to which ink is to be applied passes through the nip between the printing roller 18 and the backing roller 20. The web 22 may be supported or directed by a plurality of support rollers 24. A charge bar 26 may be disposed adjacent the printing roller 18 for applying an electric charge to the printing roller 18, as described in more detail below. The printing apparatus 10 may also include a conventional dryer (not shown) for drying the ink after it is applied to the web 22 and a conventional cooling apparatus (not shown), such as that disclosed in U.S. Patent No. 5,881,647, which is incorporated by reference herein, for cooling the web 22 after it passes through the dryer.

Fig. 2 illustrates a portion of one embodiment of a printing plate 30 (shown much larger than actual size) that is disposed on the exterior of the printing roller 18. The printing plate 30 has numerous small raised portions 32 which transfer ink from the ink roller 12 to the web 22. The raised portions 32 are non-uniform in shape and correspond to a desired image to be printed on the web 22. The raised portions 32 on the printing plate 30 may be formed via a photo-sensitive etching process in which portions of the printing plate 30 are selectively exposed to radiation, with the unexposed portions being subsequently removed via an etching agent, thus leaving the raised portions 32. The total thickness of the printing plate 30 could be approximately one-eighth to one-sixteenth of an inch, for example. Other methods of forming the raised portions 32 of the printing plate 30 could be utilized.

- 7 -

The printing plate 30 may be composed of a semi-conductive material having a resistivity in the range between about 50 thousand ohms per cubic centimeter and about 1.5 megohms per cubic centimeter, or in the range between about 100 thousand
5 ohms per cubic centimeter and about one megohm per cubic centimeter. That resistivity allows the printing plate 30 to retain an electric charge as provided by the charge bar 26 or another charge-application device.

The printing plate 30 may be composed of a photo-sensitive
10 polymer material. Photo-sensitive polymer material is commercially available in either solid or liquid form. The printing plate 30 could be made by melting photo-sensitive material in solid form and then doping the resulting liquid material, to achieve a specific resistivity or range of
15 resistivities, by dispersing conductive particles within the liquid so that the particles are in suspension in the liquid. Any type of conductive particles, such as carbon powder, powdered metals, various salts, etc., could be used. Some types of salts would be dissolve in the liquid. As an
20 alternative to doping the polymer material with a conductive agent, a photo-sensitive polymer material with semi-conductive properties could be utilized. The liquid polymer material may then be extruded through a die to form a sheet of material, which may then be cooled with a chilled roller to form a solid
25 sheet.

The solid sheet may then be photographically exposed to light or radiation through a negative of the image which is to be printed. After such exposure, the sheet is washed with, or otherwise exposed to, an etching agent, so that the areas on
30 the sheet which were photographically exposed are removed, leaving the raised portions 32.

When the printing plate 30 is made from a photo-sensitive polymer material that is in liquid form, the liquid material can be formed into a solid sheet via a mold (after suitable doping if necessary), after which the sheet is photographically etched as described above.

The fabrication methods described above result in a printing layer 30, including raised portions 32, composed entirely of semi-conductive polymer material, as shown in Fig. 2.

Fig. 3 is a cross-sectional view of a portion of the ink roller 12. Referring to Fig. 3, the outer surface of the ink roller 12 has numerous, minute recesses or wells 34 formed therein in which ink may be deposited. The ink wells 34, which are identical in shape and spacing, pick up ink from the ink reservoir 14 for transfer to the raised portions 32 on the printing plate 30 with which the ink roller 12 makes contact.

Fig. 4 illustrates the charge bar 26 in more detail. Referring to Fig. 4, the charge bar 26 has a plurality of pointed electrodes 36, which may be evenly spaced adjacent the entire length of the printing roller 18. The pointed electrodes 36 may be spaced from the outer surface of the printing roller 18 by about one-half of an inch, for example. The pointed electrodes 36 are conductively interconnected so that each is connected to a high (positive or negative) voltage, such as a voltage in the range of between about 10,000 and 30,000 volts. The proximity of that high voltage causes an electric charge to be induced in the semi-conductive printing plate 30, which enhances the transfer of ink from the raised portions 32 of the printing plate 30 to the web 22. A specific example of a charge bar that could be utilized is disclosed in U.S. Patent No. 5,881,647 entitled "Printing Press

- 9 -

With Electrostatic Cooling," which is incorporated by reference herein.

During operation of the printing apparatus 10, the rotation of the ink roller 12 causes the ink cells 34 to be periodically filled with ink. The ink in the ink cells 34 in the ink roller 12 is transferred to the raised portions 32 of the printing plate 30 on the printing roller 18 at the point at which the two rollers 12, 18 make physical contact. The ink is then transferred from the raised portions 32 to the web 22 at the nip between the printing roller 18 and the backing roller 20.

Fig. 6 illustrates one embodiment of a printing roller 18a that may be utilized in the printing apparatus 10. The printing roller 18a has a central core 40, which may be composed of metal, over which the printing plate 30 is disposed via an adhesive layer 42, such as a layer of double-backed adhesive tape. The ends of the printing plate 30 may be disposed adjacent each other at a seam 44. The adhesive layer 42 acts as an insulating layer to prevent significant amounts of electric charge from passing from the printing plate 30 to the central core 40. Alternatively, the printing plate 30 may be held in place on the printing roller 18 magnetically.

Fig. 7 illustrates a second embodiment of a printing roller 18b that may be utilized in the printing apparatus 10. The printing roller 18b is generally the same as the printing roller 18a described above in connection with Fig. 6, except that an extra insulating layer 50 is disposed between the adhesive layer 42 and the printing plate 30. The insulating layer 50 may be used to ensure that there is no significant leakage of electric charge from the semi-conductive printing plate 30 to the central core 40. Such charge leakage could

- 10 -

occur, for example, where the adhesive layer 42 is in the form of adhesive tape and where the adhesive tape does not completely cover the central core 40. The insulating layer 50 may have a resistivity greater than about two megohms per cubic centimeter. The thickness of the insulating layer 50 could be approximately one-sixteenth of an inch.

The insulating layer 50 could be glued or otherwise bonded to the printing plate 30. For example, the printing plate 30 and the insulating layer 50 could be formed via a double-extrusion process in which both layers are simultaneously extruded, each layer being extruded from a separate liquid or semi-solid, to form a respective layer, with the two layers being disposed in contact with each other to bond them together prior to their complete solidification. After the two layers 30, 50 are bonded together, the desired printing pattern would be imparted to the printing plate 30, such as by a conventional photo-sensitive etching process.

Fig. 8 illustrates a third embodiment of a printing roller 18c that may be utilized in the printing apparatus 10. The printing roller 18c is provided with a seamless semi-conductive printing plate 60 (which may have any of the resistivity ranges noted herein and which may be composed of a photo-sensitive polymer material), which is disposed on the exterior of a seamless insulating sleeve 62, which may be composed of fiberglass, for example.

Fig. 9 illustrates a fourth embodiment of a printing roller 18d that may be used in the printing apparatus 10. The printing roller 18d is generally the same as the printing roller 18b described above in connection with Fig. 7, except that a conductive layer 70 is disposed between the printing plate 30 and the insulating layer 50. The conductive layer 70

could be provided, for example, in the form of a thin, metal layer plated onto or otherwise provided on the outer surface of the insulating layer 50 or the inner surface of the printing plate 30.

5 The purpose of the conductive layer 70 is to allow an electric charge to be applied to the printing roller 18, via direct physical contact, so that a lower voltage can be used to apply the charge. Fig. 5 illustrates one manner in which an electric charge could be directly applied to a portion of
10 the printing roller 18d. Referring to Fig. 5, the electric charge could be applied via a conductive brush 72 that makes contact with a conductive surface 74 integrally formed or otherwise conductively connected to the conductive layer 70. Since direct contact is made, the conductive brush 72 could be
15 connected to a voltage source providing a voltage in the range of one thousand to three thousand volts, for example, instead of the higher voltage necessary for the charge bar 26.

Fig. 10 illustrates an alternative embodiment of a printing plate 30b that could be used in each of the
20 embodiments of Figs. 6-9. Referring to Fig. 10, the printing plate 30b has a substrate layer 80 and a printing layer composed of raised portions 32b, with each raised portion 32b having a raised surface 32c. Together, the raised surfaces 32c of the raised portions 32b make up the desired image-forming
25 surface. The raised portions 32b may be composed of photo-sensitive material. The substrate layer 80 may comprise an insulating layer having a resistivity in excess of about two megohms per cubic centimeter.

The printing plate 30b of Fig. 10 may be manufactured by
30 depositing or otherwise forming a layer of semi-conductive, photo-sensitive polymer material on top of an insulating

- 12 -

substrate. The semi-conductive material may then be photo-etched, as described above, until all semi-conductive material except for the raised portions 32 is removed.

Numerous additional modifications and alternative
5 embodiments of the invention will be apparent to those skilled
in the art in view of the foregoing description. This
description is to be construed as illustrative only, and is for
the purpose of teaching those skilled in the art the best mode
of carrying out the invention. The details of the structure
10 and method may be varied substantially without departing from
the spirit of the invention, and the exclusive use of all
modifications which come within the scope of the appended
claims is reserved.

WHAT IS CLAIMED IS:

1. A flexographic printing apparatus for printing a moving web, said printing apparatus comprising:

5 a rotatable ink roller;
a roller support that rotatably supports said ink roller;
an ink source associated with said ink roller, said ink source providing ink to be applied to said ink roller;

10 a rotatable printing roller associated with said ink roller;

a printing plate disposed on said printing roller, said printing plate making physical contact with said ink roller so that ink is transferred from said ink roller to said printing plate as said ink roller and said printing roller rotate, said
15 printing plate comprising:

a semi-conductive printing layer having an image-forming surface, said semi-conductive printing layer having a resistivity in the range between about 50 thousand ohms per cubic centimeter and about 1.5 megohms
20 per cubic centimeter; and

an insulating layer disposed between said semi-conductive layer and said printing roller, said insulating layer having a resistivity of greater than about two megohms per cubic centimeter;

25 a rotatable backing roller disposed adjacent said printing roller so that said moving web on which ink is to be applied passes between said backing roller and said printing plate as said backing roller and said printing roller rotate so that a printed image is applied to said web; and

a charge applicator associated with said printing roller, said charge applicator causing an electric charge to be applied to said semi-conductive printing plate.

5 2. A printing apparatus as defined in claim 1 wherein said charge applicator comprises an elongate charge bar having a plurality of charging electrodes spaced from said printing roller.

10 3. A printing apparatus as defined in claim 1 wherein said charge applicator makes physical contact with a portion of said printing plate.

15 4. A printing apparatus as defined in claim 1 wherein said insulating layer of said printing plate comprises an insulating sleeve.

20 5. A printing apparatus as defined in claim 1 wherein said insulating layer of said printing plate comprises a fiberglass sleeve.

25 6. A printing apparatus as defined in claim 1 wherein said semi-conductive printing layer comprises a photo-sensitive polymer doped with conductive particles.

30 7. A printing apparatus as defined in claim 1 wherein said semi-conductive printing layer has a resistivity in the range between about 100 thousand ohms per cubic centimeter and about one megohm per cubic centimeter.

- 15 -

8. A flexographic printing apparatus for printing a moving web, said printing apparatus comprising:

a rotatable ink roller;

a roller support that rotatably supports said ink roller;

5 an ink source associated with said ink roller, said ink source providing ink to be applied to said ink roller;

a rotatable printing roller associated with said ink roller;

10 a printing plate disposed on said printing roller, said printing plate having an image-forming surface, said printing plate making physical contact with said ink roller so that ink is transferred from said ink roller to said printing plate as said ink roller and said printing roller rotate;

15 a rotatable backing roller disposed adjacent said printing roller so that said moving web on which ink is to be applied passes between said backing roller and said printing plate as said backing roller and said printing roller rotate so that a printed image is applied to said web; and

20 a charge applicator associated with said printing roller, said charge applicator causing an electric charge to be applied to said printing plate.

9. A printing apparatus as defined in claim 8 wherein said printing plate comprises a photo-sensitive polymer doped
25 with conductive particles.

10. A printing apparatus as defined in claim 8 wherein said charge applicator comprises an elongate charge bar having a plurality of charging electrodes spaced from said printing
30 roller.

- 16 -

11. A printing apparatus as defined in claim 8 wherein said charge applicator makes physical contact with a portion of said printing plate.

5 12. A printing apparatus as defined in claim 8 additionally comprising an adhesive layer disposed between said printing plate and said printing roller.

10 13. A flexographic printing apparatus for printing a moving web, said printing apparatus comprising:

a rotatable ink roller;

a roller support that rotatably supports said ink roller;

an ink source associated with said ink roller, said ink source providing ink to be applied to said ink roller;

15 a rotatable printing roller associated with said ink roller;

a printing structure disposed on said printing roller, said printing structure making physical contact with said ink roller so that ink is transferred from said ink roller to said printing structure as said ink roller and said printing roller rotate, said printing structure comprising:

25 a semi-conductive printing layer having an image-forming surface, said semi-conductive printing layer having a resistivity in the range between about 50 thousand ohms per cubic centimeter and about 1.5 megohms per cubic centimeter;

30 a conductive layer disposed adjacent said semi-conductive printing layer, said conductive layer having a resistivity lower than about 50 thousand ohms per cubic centimeter; and

- 17 -

an insulating layer disposed between said conductive layer and said printing roller, said insulating layer having a resistivity of greater than about two megohms per cubic centimeter;

5 a rotatable backing roller disposed adjacent said printing roller so that said moving web on which ink is to be applied passes between said backing roller and said printing structure as said backing roller and said printing roller rotate so that a printed image is applied to said web; and

10 a charge applicator associated with said printing roller, said charge applicator causing an electric charge to be applied to said semi-conductive printing layer.

14. A printing apparatus as defined in claim 13 wherein
15 said semi-conductive printing layer has a resistivity in the range between about 100 thousand ohms per cubic centimeter and about one megohm per cubic centimeter.

15. A printing apparatus as defined in claim 13 wherein
20 said charge applicator makes physical contact with a portion of said conductive layer of said printing structure.

16. A printing structure for a flexographic printing apparatus having a rotatable ink roller, a roller support that
25 rotatably supports said ink roller, an ink source associated with said ink roller which provides ink to be applied to said ink roller, a rotatable printing roller associated with said ink roller, and a rotatable backing roller disposed adjacent said printing roller, said printing structure comprising:

- 18 -

a semi-conductive printing layer adapted to be disposed on a printing roller, said semi-conductive printing layer comprising:

5 a photo-sensitive polymer material having a resistivity in the range between about 50 thousand ohms per cubic centimeter and about 1.5 megohms per cubic centimeter; and

10 an image-forming surface on said photo-sensitive polymer material, said image-forming surface having a plurality of raised areas corresponding to an image to be printed.

15 17. A printing structure as defined in claim 16 wherein said semi-conductive printing layer has a thickness of less than about one-fourth of an inch.

20 18. A printing structure as defined in claim 16 wherein said semi-conductive printing layer has a resistivity in the range between about 100 thousand ohms per cubic centimeter and about one megohm per cubic centimeter.

25 19. A printing structure for a flexographic printing apparatus having a rotatable ink roller, a roller support that rotatably supports said ink roller, an ink source associated with said ink roller which provides ink to be applied to said ink roller, a rotatable printing roller associated with said ink roller, and a rotatable backing roller disposed adjacent said printing roller, said printing structure comprising:

30 a semi-conductive printing layer adapted to be disposed on a printing roller, said semi-conductive printing layer comprising:

- 19 -

a photo-sensitive polymer material having a resistivity in the range between about 50 thousand ohms per cubic centimeter and about 1.5 megohms per cubic centimeter; and

5 an image-forming surface on said photo-sensitive polymer material, said image-forming surface having a plurality of raised areas corresponding to an image to be printed; and

10 an insulating layer disposed adjacent said semi-conductive printing layer, said insulating layer having a resistivity of greater than about two megohms per cubic centimeter.

20. A printing structure as defined in claim 19 wherein said photo-sensitive polymer material has a concentration of
15 conductive particles dispersed therein to provide said semi-conductive printing layer with a resistivity in the range between about 50 thousand ohms per cubic centimeter and about 1.5 megohms per cubic centimeter.

20 21. A printing structure as defined in claim 19 wherein said insulating layer comprises an insulating sleeve.

22. A printing structure as defined in claim 19 wherein said insulating layer comprises a fiberglass sleeve.

25 23. A printing structure as defined in claim 19 wherein said printing structure has a thickness of less than about one-fourth of an inch.

30 24. A printing structure as defined in claim 19 wherein said semi-conductive printing layer has a resistivity in the

- 20 -

range between about 100 thousand ohms per cubic centimeter and about one megohm per cubic centimeter.

25. A printing structure for a flexographic printing apparatus having a rotatable ink roller, a roller support that rotatably supports said ink roller, an ink source associated with said ink roller which provides ink to be applied to said ink roller, a rotatable printing roller associated with said ink roller, and a rotatable backing roller disposed adjacent said printing roller, said printing structure comprising:

a semi-conductive printing layer adapted to be disposed on a printing roller, said semi-conductive printing layer comprising:

a photo-sensitive polymer material having a resistivity in the range between about 50 thousand ohms per cubic centimeter and about 1.5 megohms per cubic centimeter; and

an image-forming surface on said photo-sensitive polymer material, said image-forming surface having a plurality of raised areas corresponding to an image to be printed;

a conductive layer disposed adjacent said semi-conductive printing layer, said conductive layer having a resistivity lower than about 50 thousand ohms per cubic centimeter; and

an insulating layer disposed adjacent said conductive layer, said insulating layer having a resistivity of greater than about two megohms per cubic centimeter.

26. A printing structure as defined in claim 25 wherein said photo-sensitive polymer material has a concentration of conductive particles dispersed therein to provide said photo-

sensitive polymer material with a resistivity in the range between about 50 thousand ohms per cubic centimeter and about 1.5 megohms per cubic centimeter.

5 27. A printing structure as defined in claim 25 wherein said insulating layer comprises an insulating sleeve.

 28. A printing structure as defined in claim 25 wherein said insulating layer comprises a fiberglass sleeve.

10

 29. A printing structure as defined in claim 25 wherein said printing structure has a thickness of less than about one-fourth of an inch.

15 30. A printing structure as defined in claim 25 wherein said semi-conductive printing layer has a resistivity in the range between about 100 thousand ohms per cubic centimeter and about one megohm per cubic centimeter.

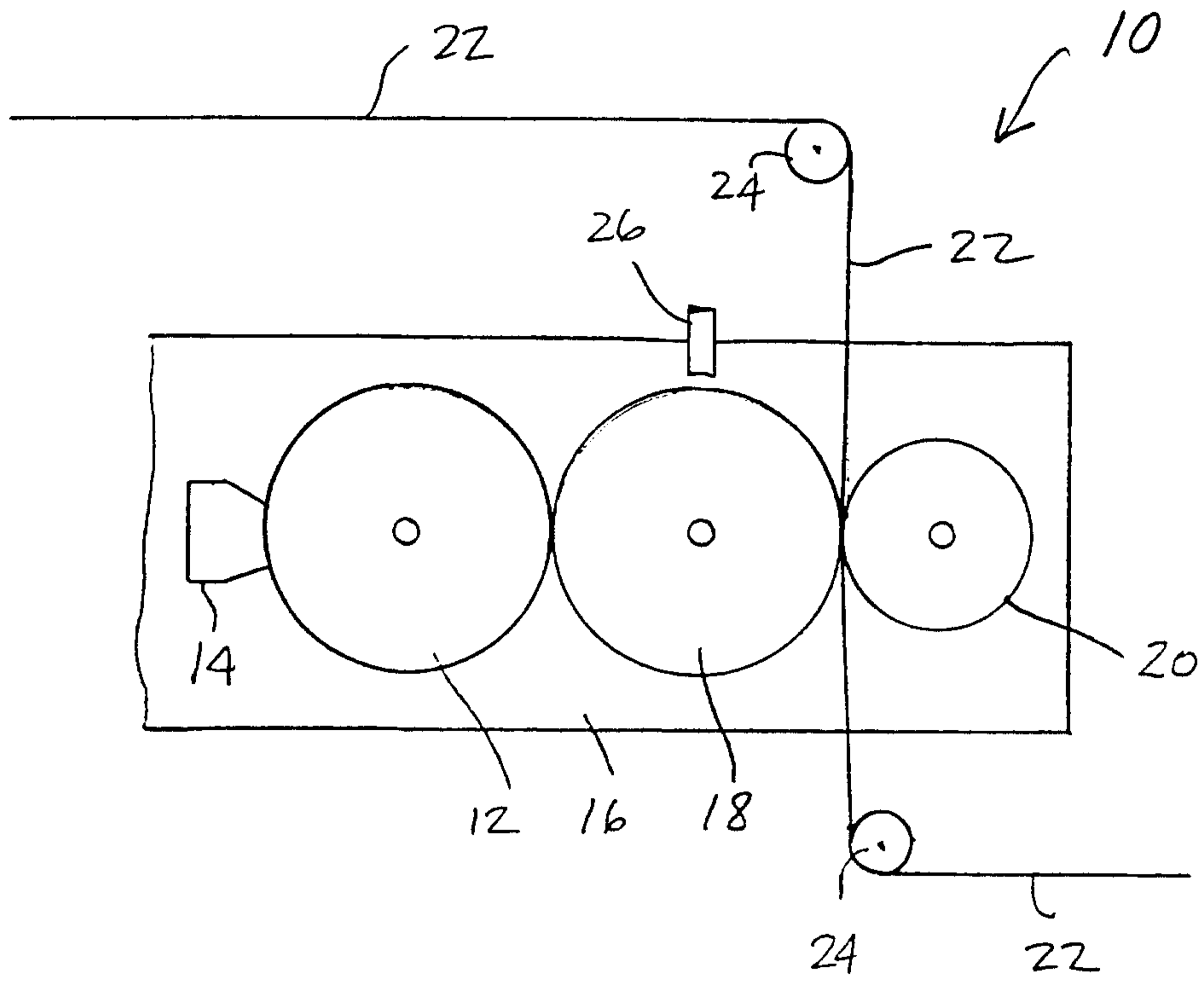

FIG. 1

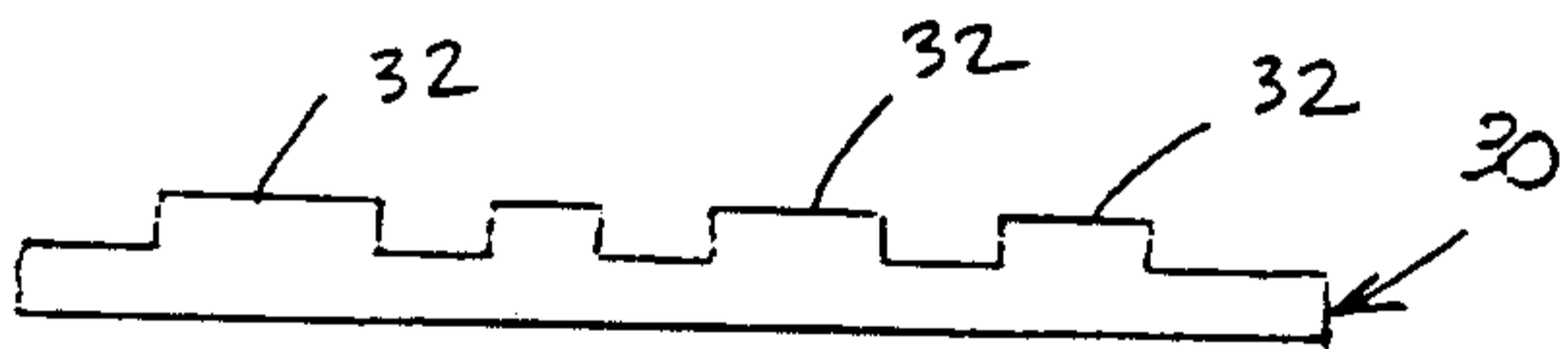

FIG. 2

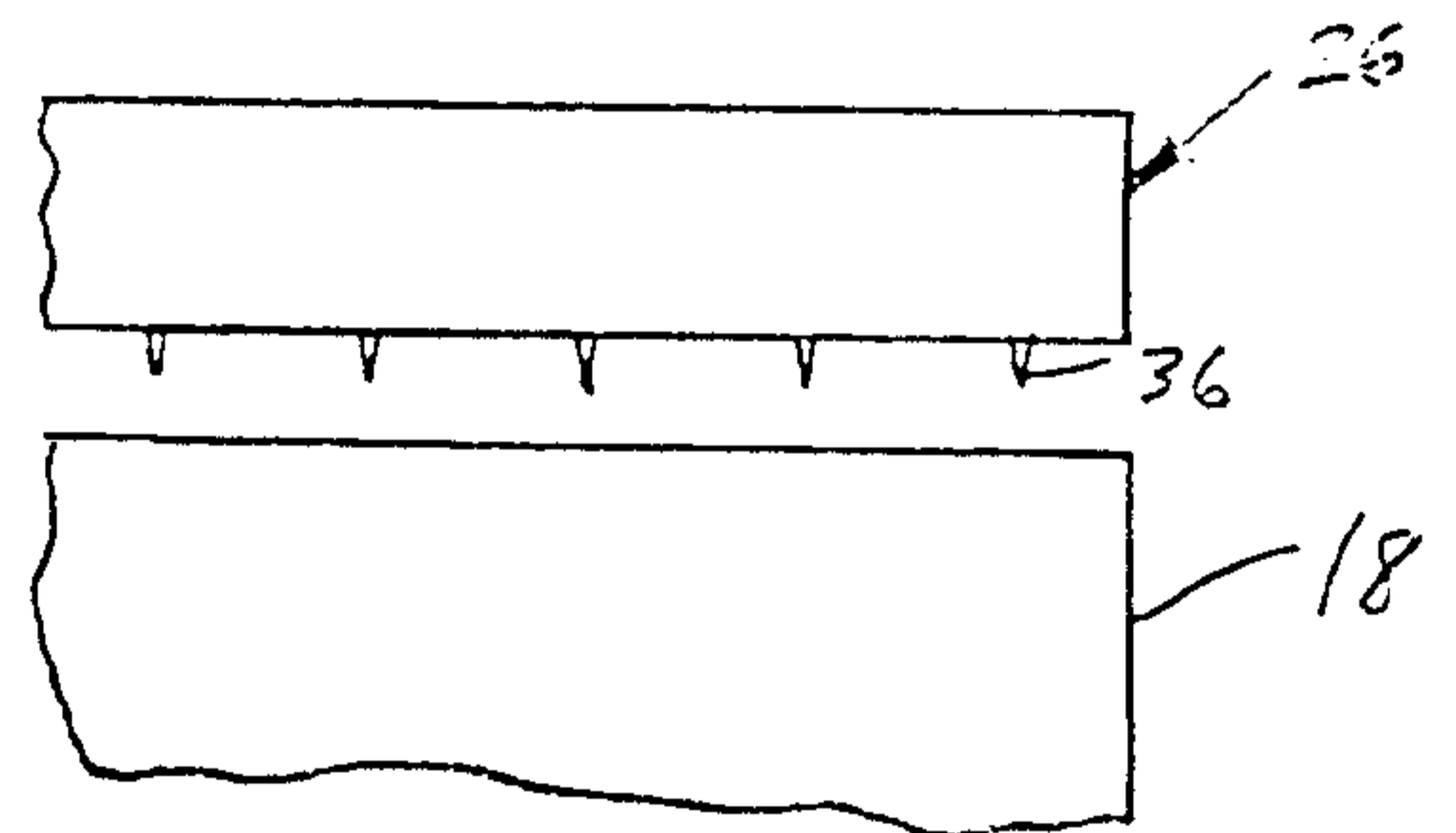

FIG. 4

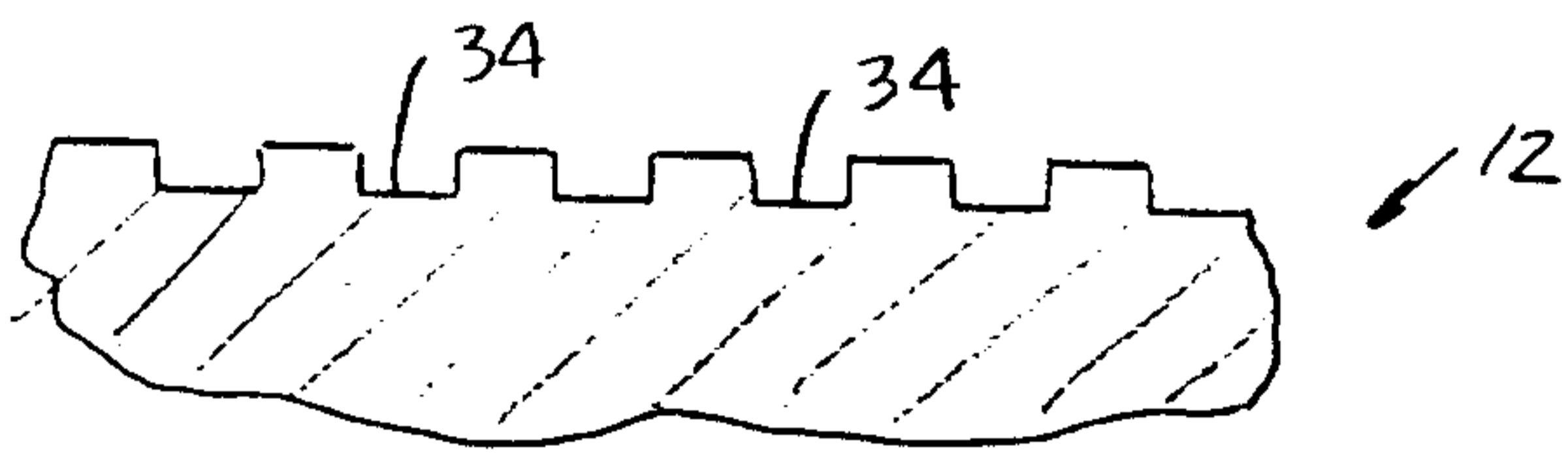

FIG. 3

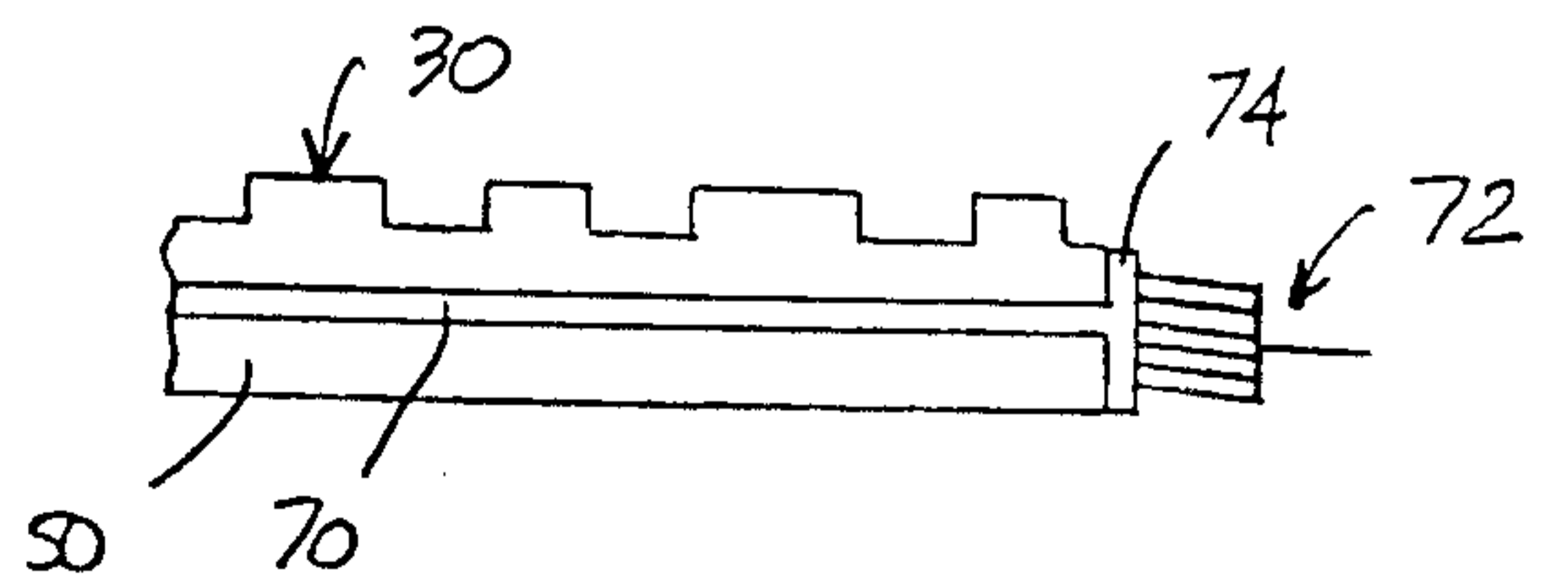

FIG. 5

Tralagon & Bengtsson
PATENT AGENTS

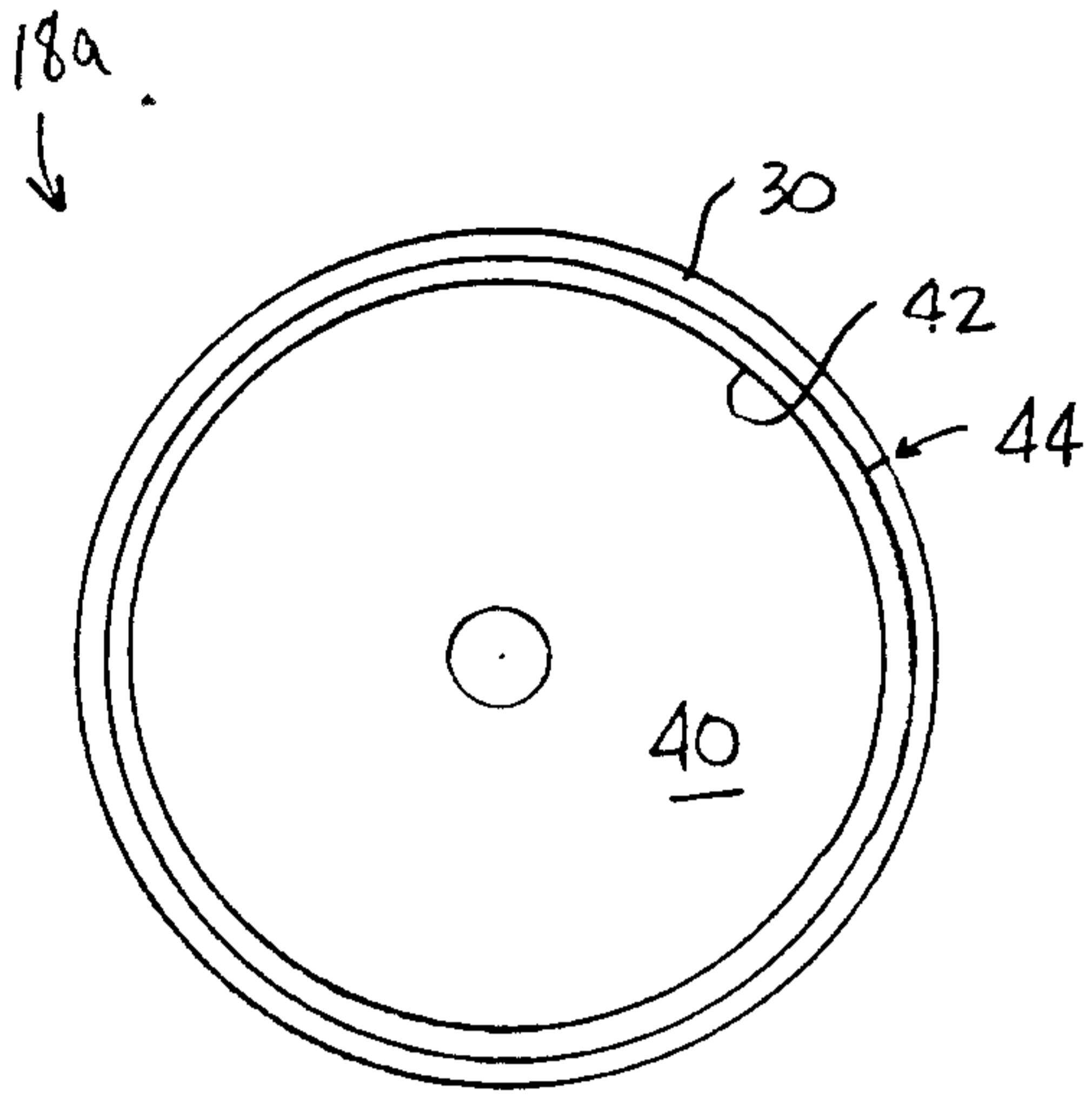

FIG. 6

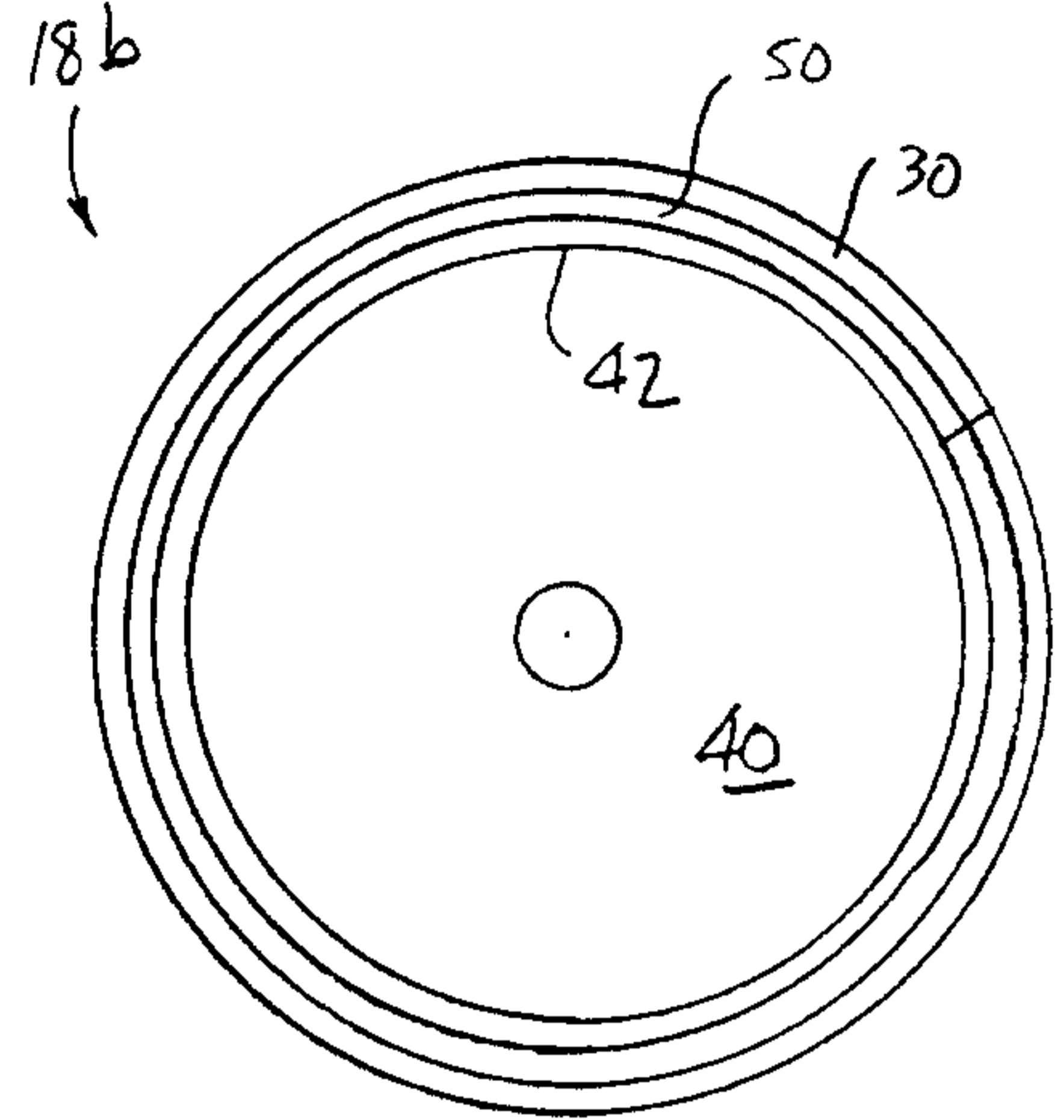

FIG. 7

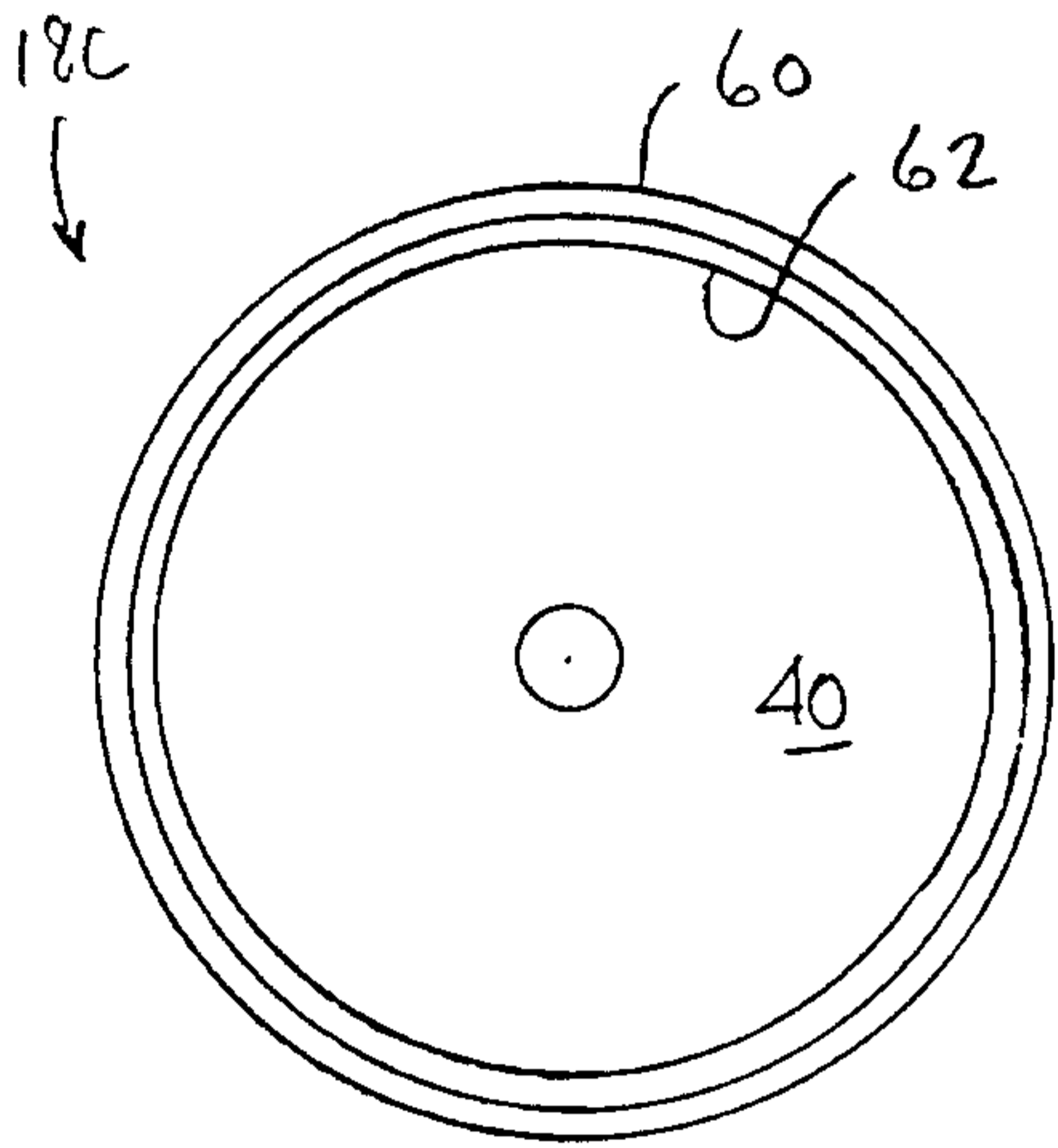

FIG. 8

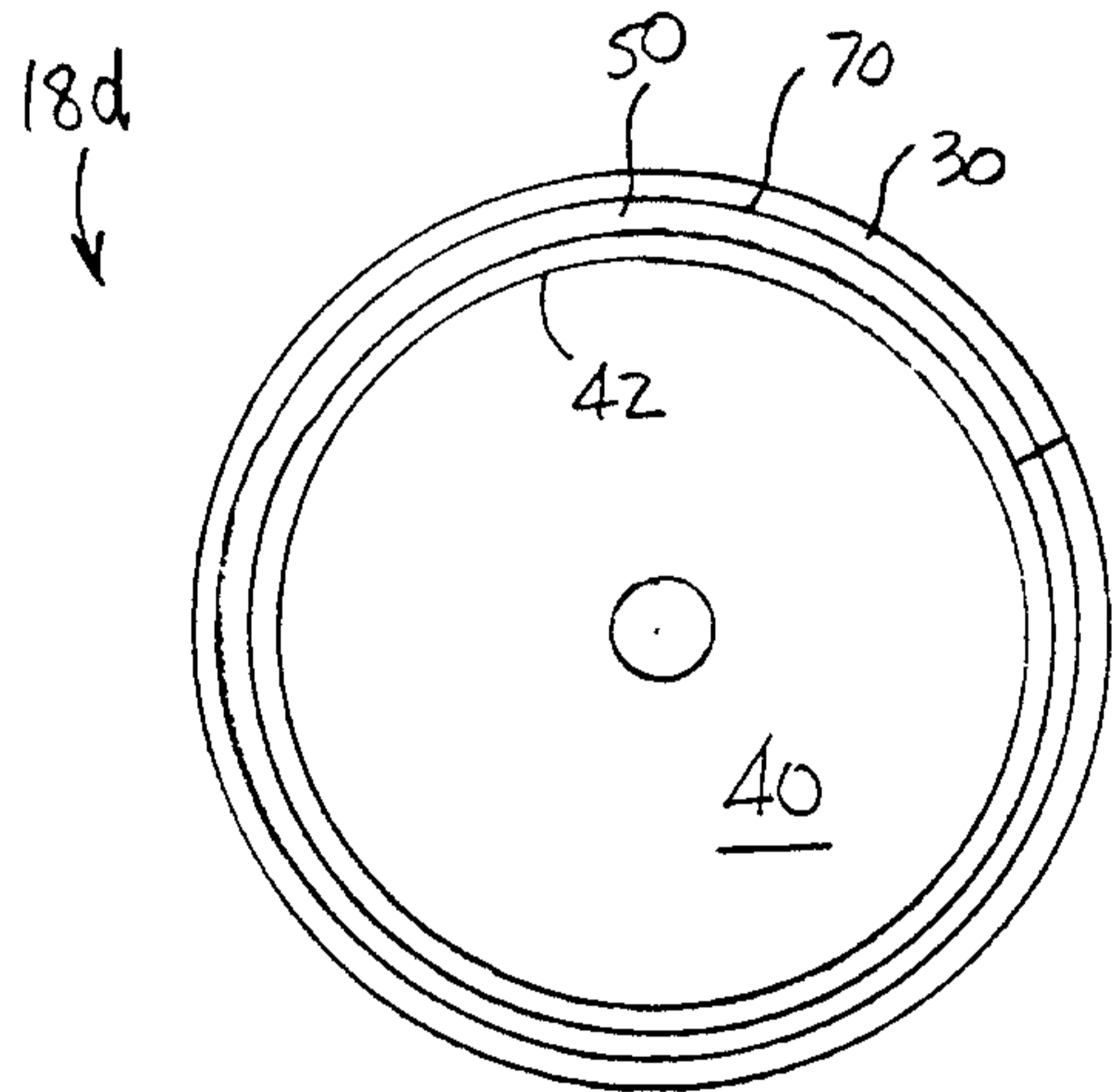

FIG. 9

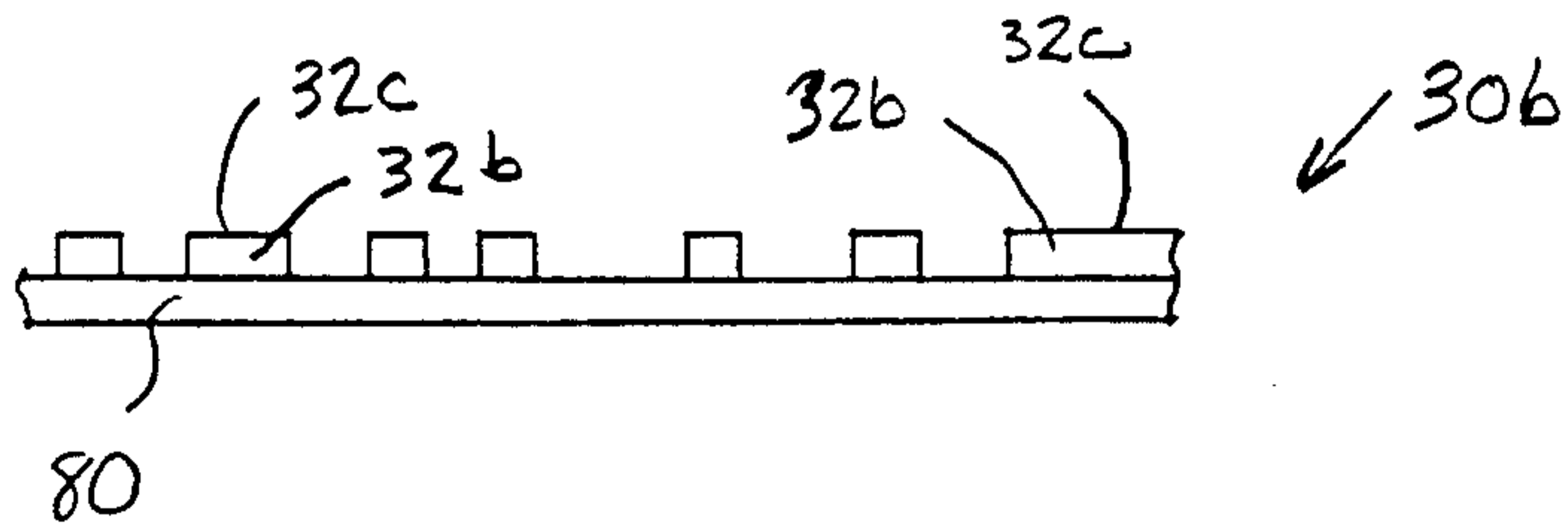

FIG. 10

