

(No Model.)

2 Sheets—Sheet 1.

T. J. WALSH.
RAILROAD SWITCH.

No. 473,801.

Patented Apr. 26, 1892.

Fig. 1.

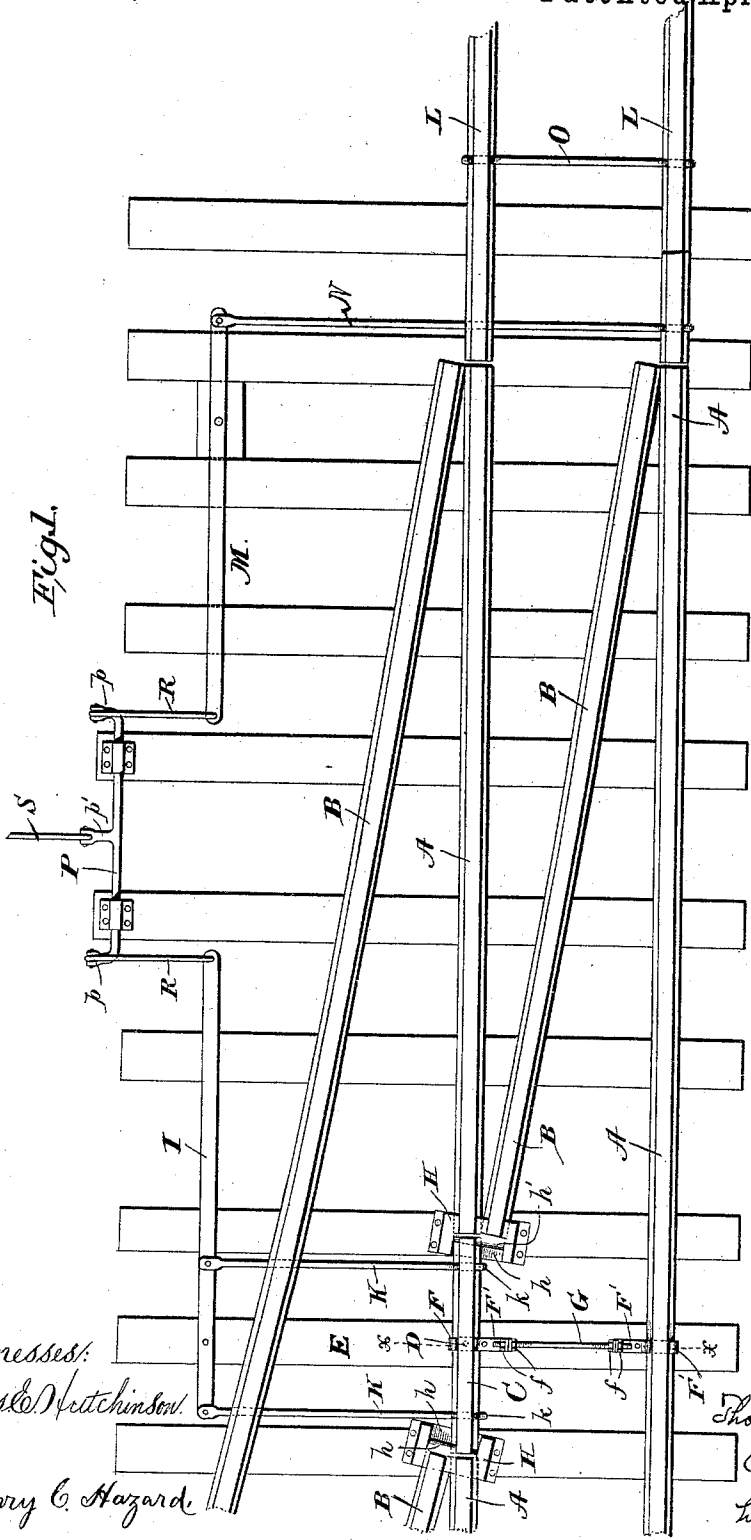

Witnesses:
James D. Hutchinson
Henry C. Hazard

Inventor
T. J. Walsh, by
Charles H. Russell
his Attorney

T. J. WALSH.
RAILROAD SWITCH.

No. 473.801.

Patented Apr. 26, 1892.

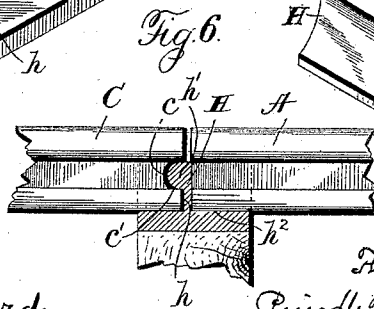
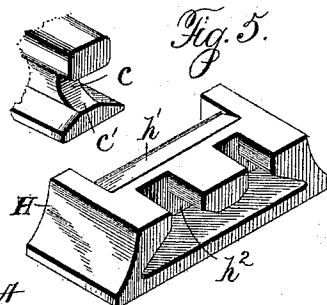
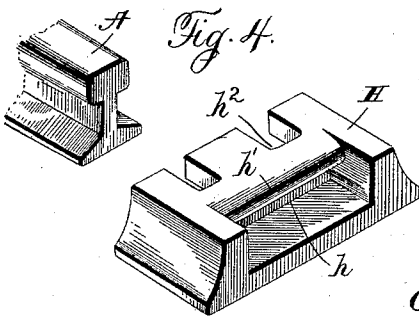
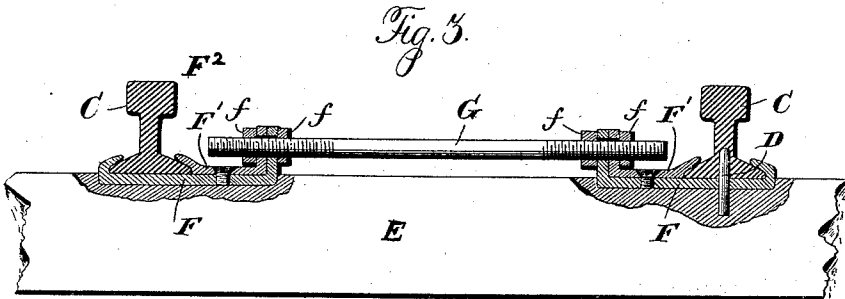
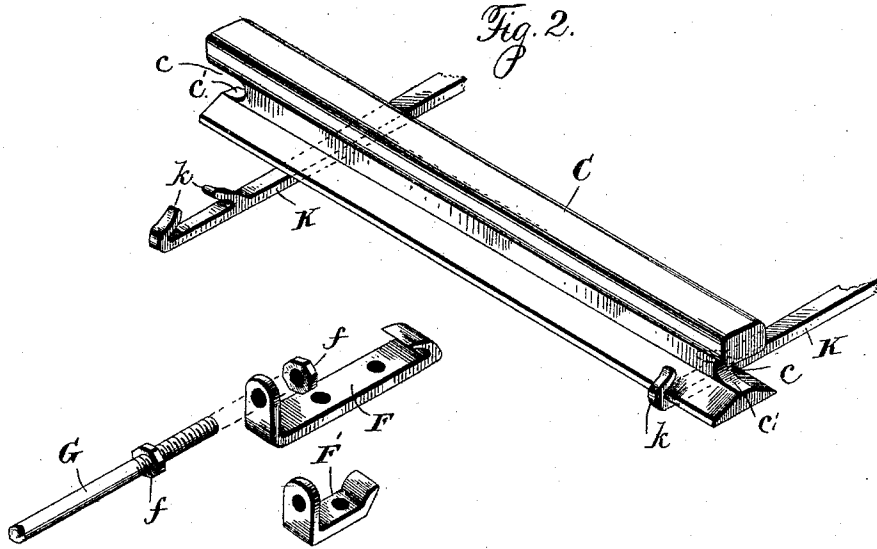

Witnesses:
Jas. E. Hutchinson.
Henry C. Hazard.

Inventor.
Thos. J. Walsh, by
Charles Russell his atty.

UNITED STATES PATENT OFFICE.

THOMAS J. WALSH, OF PRICEBURG, PENNSYLVANIA.

RAILROAD-SWITCH.

SPECIFICATION forming part of Letters Patent No. 473,801, dated April 26, 1892.

Application filed July 11, 1891. Serial No. 399,194. (No model.)

To all whom it may concern:

Be it known that I, THOMAS J. WALSH, a citizen of the United States of America, and a resident of Priceburg, in the county of Lackawanna, and in the State of Pennsylvania, have invented certain new and useful Improvements in Railway-Switches; and I do hereby declare that the following is a full, clear, and exact description thereof, reference being had to the accompanying drawings, in which—

Figure 1 is a plan view of a section of railroad equipped with a switch constructed in accordance with my invention; Fig. 2, a perspective view of the movable rail used in the place of a frog and portions of the bracing device therefor and the links connecting it to the operating-lever. Fig. 3 is a transverse section on the line xx of Fig. 1. Figs. 4 and 5 are detail views in perspective from opposite sides of the chair used to receive and hold the ends of the movable and fixed rails, and Fig. 6 a detail section through said chair with the rails in place therein.

Letters of like name and kind refer to like parts throughout the several figures.

The object of my invention has been to make certain improvements in that class of railroad-switches in which a movable rail is employed instead of a frog to establish connection between the proper sections of rail where the main rail and the siding-rail intersect; and to such end it consists in the mechanism and the parts thereof constructed and arranged substantially as and for the purpose hereinafter specified.

In the drawings, A and A designate the rails of the main line of a railroad, and B and B the rails of a siding. At the point of intersection of one of the main and one of the siding rails a short section of each is removed, and in the space thus formed is a rail-section C, pivoted at its longitudinal center and of such length as to extend across such space. This rail-section C may be vibrated or swung on its pivot to establish the continuity of either the main-line rail or the siding-rail, as may be desired, by mechanism to be hereinafter described. The pivot of the rail-section C is a vertical stud or pin D, fixed in and projecting above the surface of the cross-tie E, which stud or pin engages an opening in the under side of the rail-section. The latter is securely

held against all possibility of dislodgment at its pivot and is strongly braced thereat by the following-described device, viz: Beneath the rail-section at its pivotal point is placed a plate F, having one of its ends bent so as to overlap the rail-flange on one side, and superimposed upon a portion of the former that projects to one side of said section is a second plate F', having one of its ends bent over and engaging the other side of the rail-flange. The other ends of both plates are extended upward at right angles to the body or main portions thereof side by side, and through openings therein the end of a brace bar or rod G extends from a similarly-constructed rail-engaging device F² on the oppositely-located main rail A.

The manner of securing the brace-bar G to the rail-engaging devices is by means of two nuts f and f' , which engage or abut against the upturned portions of the two plates thereof on opposite sides, the brace-bar ends being screw-threaded for engagement by the nuts. The vibratory section C is thus braced from the opposite main rail and can always be rigidly held at its pivot, as any slack or looseness in the parts of the bracing device which might be caused by the passage of trains can be taken up simply by an adjustment of the nuts on the brace-bar. Each rail-engaging part of the brace device is placed in a cavity or recess in the upper side of the tie or sleeper upon which the same is mounted, which cavity has such depth as to bring the upper side of the lower plate flush with the upper side of the tie. These cavities serve, also, to prevent sidewise dislodgment of said rail-engaging devices. The plates F and F' may be attached to each other by bolts. Each free end of the movable or vibratory rail-section C is contained in a chair, which consists of a block H, secured to one of the cross-ties by spikes or bolts. Said block has a recess h in its side, in which the rail end is placed and against whose end walls said end will strike as the rail is moved to one side or the other, thus limiting its movement and preventing its being thrown out of alignment with the fixed rail with which it is intended to act.

To hold the rail-section C from rising upward, a slot or notch c is cut in each end, into which extends a lip or flange h' , that projects

from the block H, against which the lower projecting portion *c'*, formed by notching the rail end, will strike or abut on any upward tendency. The block H also serves as a chair
 5 for the ends of the main and siding rails, being for this purpose provided on its side opposite that engaging the movable rail with a cavity *h*², **┐**-shaped in elevation for one end
 10 of each of said rails, adapted to receive the flange and vertical web portions thereof. These cavities *h*² should extend far enough into the block to enable the ends of the fixed rails to be placed sufficiently close to the end of the movable rail.

15 For shifting or vibrating the movable rail-section C, I provide a lever I, pivoted upon one of the ties outside of the outer siding-rail and connected at points on opposite sides of its pivot by means of two parallel links K and
 20 K with the rail near its ends. These links are attached to the rail by having their ends thereat passed beneath the rail, with whose flange lugs *h* and *k* thereon engage. Said lugs project upwardly from the links and overhang the flange on opposite sides. By the
 25 employment of two links connected to the rail at points on both sides of its pivot it can be vibrated much more readily than were but one used and the likelihood of failing to swing it
 30 is minimized. It is to be noted, too, that the links extend in a direction opposite the brace-rod G, thus serving to brace the rail against movement in such direction. Said rail thus has its stability insured at its center and its
 35 two ends against side-thrust in the two directions likely for it to have movement.

The switch-rails L and L are of ordinary construction and are shiftable by means of a
 40 lever M, pivoted in line with the lever I outside the outer siding-rail. It is connected by a link N to the one of said switch-rails farthest therefrom, the said link having upwardly-extended lugs, which overhang and engage the rail-flange on opposite sides, and a link O
 45 connects such rail to the other. The two shifting-levers I and M extend toward each other from their pivots, and their free ends are brought close enough together to enable them to be connected to the same operating device,
 50 so that both can be simultaneously moved to cause the simultaneous shifting of the pivoted rail-section C and the switch-rails L and L.

The operating device I show consists of a horizontal rock-shaft P, journaled parallel
 55 with said levers and having at each of its ends a crank-arm *p*, that is connected by a link R with the free end of the lever adjacent thereto. Said rock-shaft at its longitudinal center has a third crank-arm *p'*, which by means of a
 60 link S is connected with a suitable switch-lever by which the shaft may be rocked or vibrated.

Having thus described my invention, what I claim is—

1. In a railroad-switch, in combination with
 65 the separated rails, the pivoted rail-section and the brace rod or bar having adjusting means and connected to said section at its pivotal point, substantially as and for the purpose set forth. 70

2. In a railroad-switch, in combination with the movable rail-section pivoted between its ends, the bracing device extending from the pivot thereof to an adjacent fixed rail, substantially as and for the purpose described. 75

3. In a railroad-switch, in combination with the movable rail-section pivoted between its ends, the bracing device consisting of the rail-flange-engaging plates and a rod or bar connected thereto and to another fixed point, substantially as and for the purpose specified. 80

4. In a railroad-switch, in combination with the movable rail-section pivoted between its ends, the bracing device consisting of the two plates having each a lug engaging the flange
 85 of such section on opposite sides and having the upturned portions and the brace rod or bar attached at one end to the latter and at its other to some fixed point, substantially as and for the purpose shown. 90

5. In a railroad-switch, in combination with the movable rail-section pivoted between its ends, the bracing device consisting of the two plates placed one upon the other at the pivot thereof, having each a lug engaging the flange
 95 of such section and having the upturned portions, and the brace-bar passing through the latter and having nuts on opposite sides thereof and connected to an adjacent fixed rail, substantially as and for the purpose set forth. 100

6. In a railroad-switch, in combination with the movable rail-section and the pivot pin or stud therefor, the bracing device consisting of plates engaging the section through which
 105 passes said pivot-pin and a brace-bar connected to said plates, substantially as and for the purpose described.

7. In a railroad-switch, in combination, the rail-sections to be connected, the movable rail pivoted between its ends, the bracing device
 110 extending from its pivot to an adjacent fixed rail, the shifting-lever, and the two links connecting said movable rail on both sides of its pivot to said lever, said links and lever being located opposite the bracing device, substantially as and for the purpose specified. 115

In testimony that I claim the foregoing I have hereunto set my hand this 13th day of June, A. D. 1891.

THOS. J. WALSH.

Witnesses:

JNO. F. O'HARA,
 WM. J. TRACY.