



US 20070102131A1

(19) **United States**

(12) **Patent Application Publication**
Raffle

(10) **Pub. No.: US 2007/0102131 A1**

(43) **Pub. Date: May 10, 2007**

(54) **CASTING OF METAL ARTEFACTS**

Publication Classification

(76) Inventor: **Marie Thomas Gilles Raffle, Benoni**
(ZA)

(51) **Int. Cl.**
B22D 27/04 (2006.01)
B22D 17/08 (2006.01)
(52) **U.S. Cl.** **164/121**; 164/338.1; 164/312;
164/66.1

Correspondence Address:
FISH & RICHARDSON PC
P.O. BOX 1022
MINNEAPOLIS, MN 55440-1022 (US)

(57) **ABSTRACT**

(21) Appl. No.: **10/596,017**

(22) PCT Filed: **Nov. 24, 2004**

(86) PCT No.: **PCT/IB04/03838**

§ 371(c)(1),
(2), (4) Date: **Aug. 17, 2006**

The invention provides a process, casting assembly (10) and casting apparatus for charging a mould (12) with molten metal and solidifying it in the mould to form an artefact, the process including, prior to charging the mould, heating the mould by induction heating to an elevated temperature at which the charging takes place. The assembly (10) includes a mould (12) for casting the artefact and an induction heating arrangement (14), which includes at least one induction coil surrounding the mould, for heating it to an elevated temperature prior to the casting. The apparatus (20) includes the assembly (10) and a melting apparatus (4) for forming a molten charge of metal, the apparatus (40) including a heating arrangement (44) for heating a precursor of the molten charge to melt it.

(30) **Foreign Application Priority Data**

Nov. 26, 2003 (ZA)..... 2003/9208

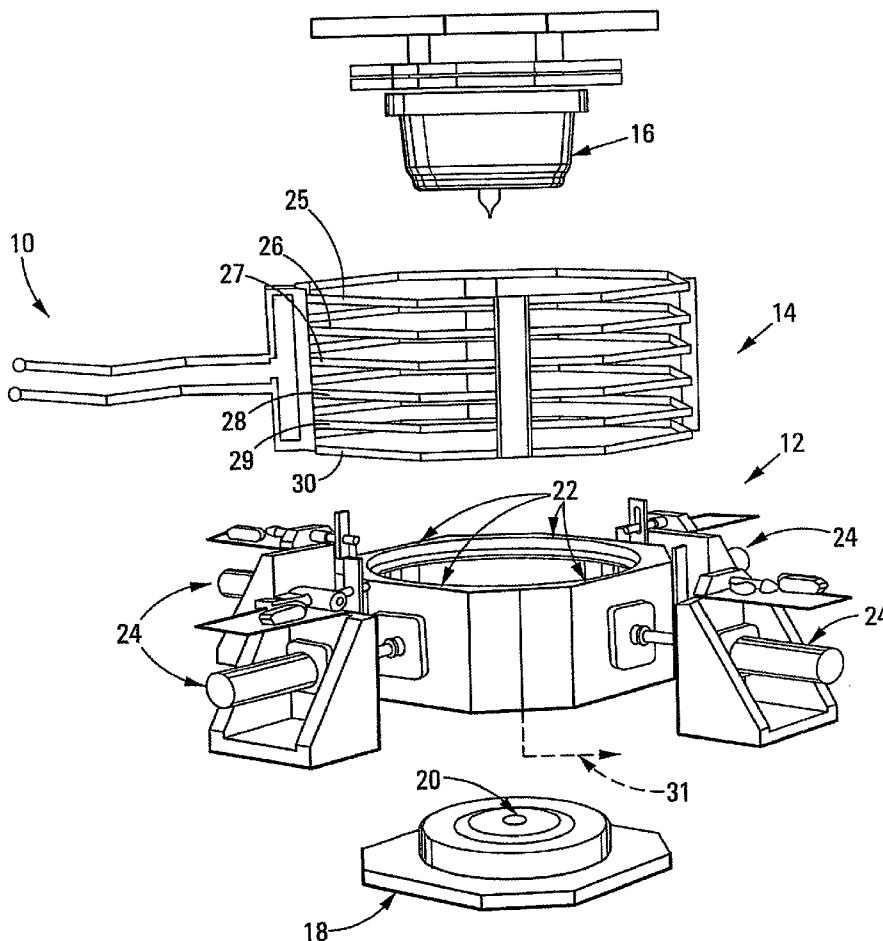

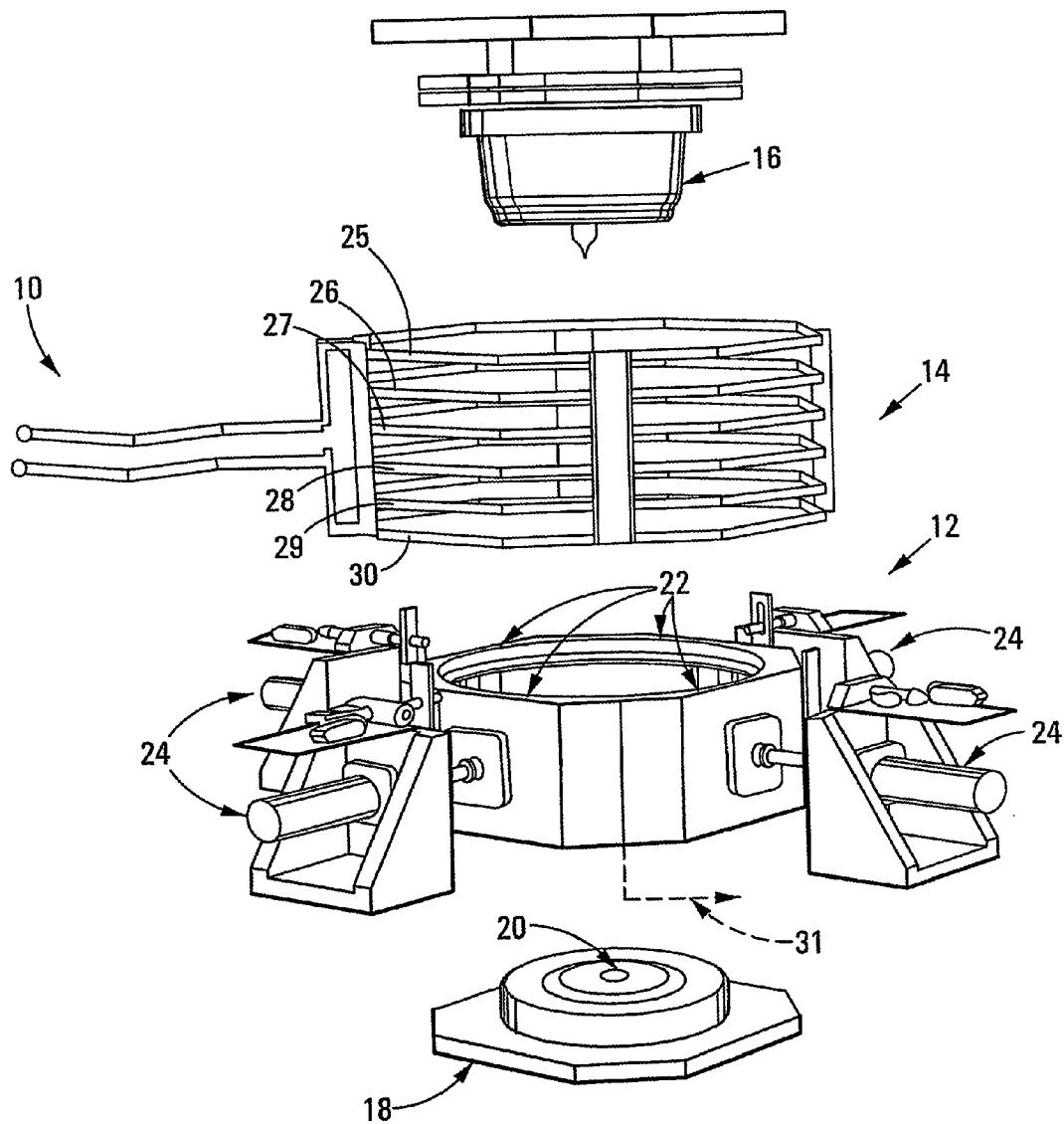

FIG 1

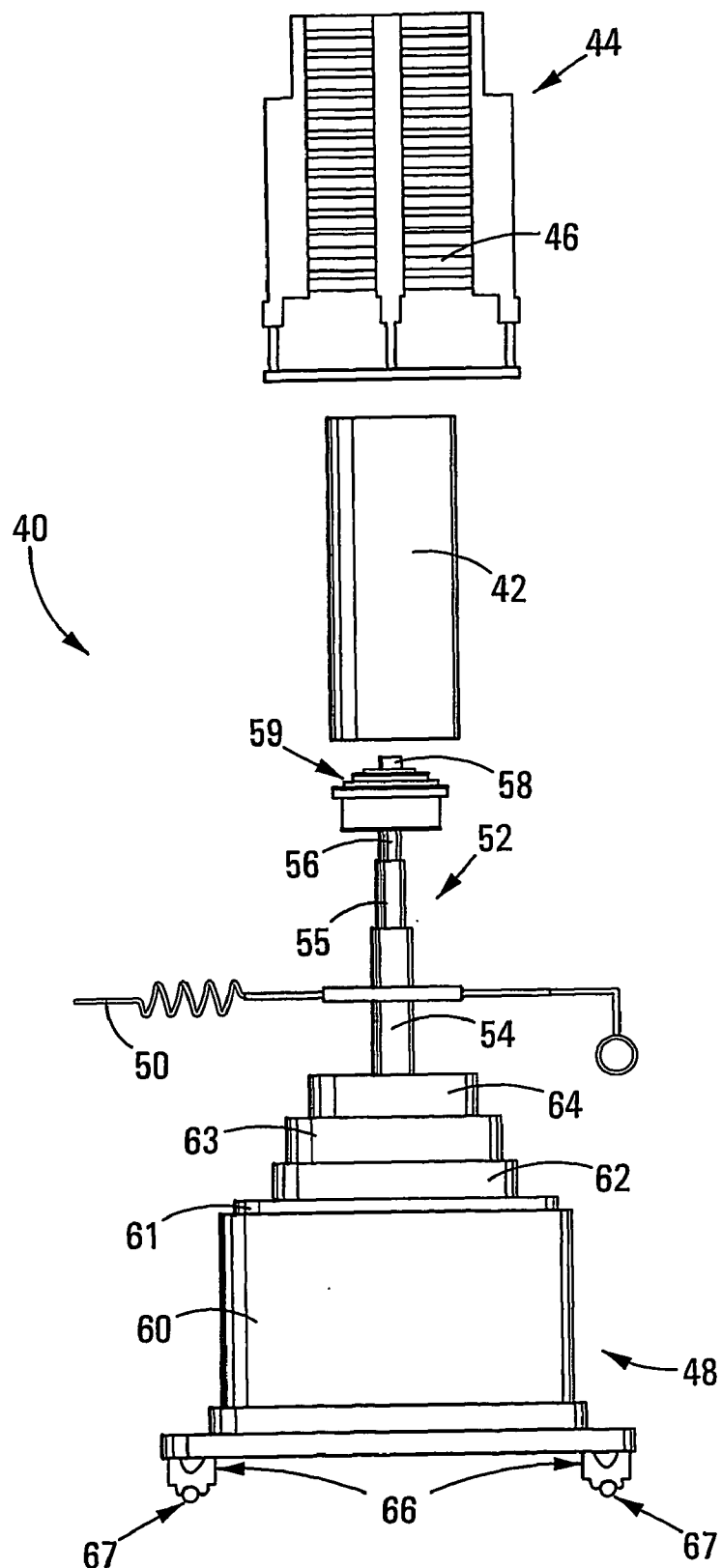

FIG 2

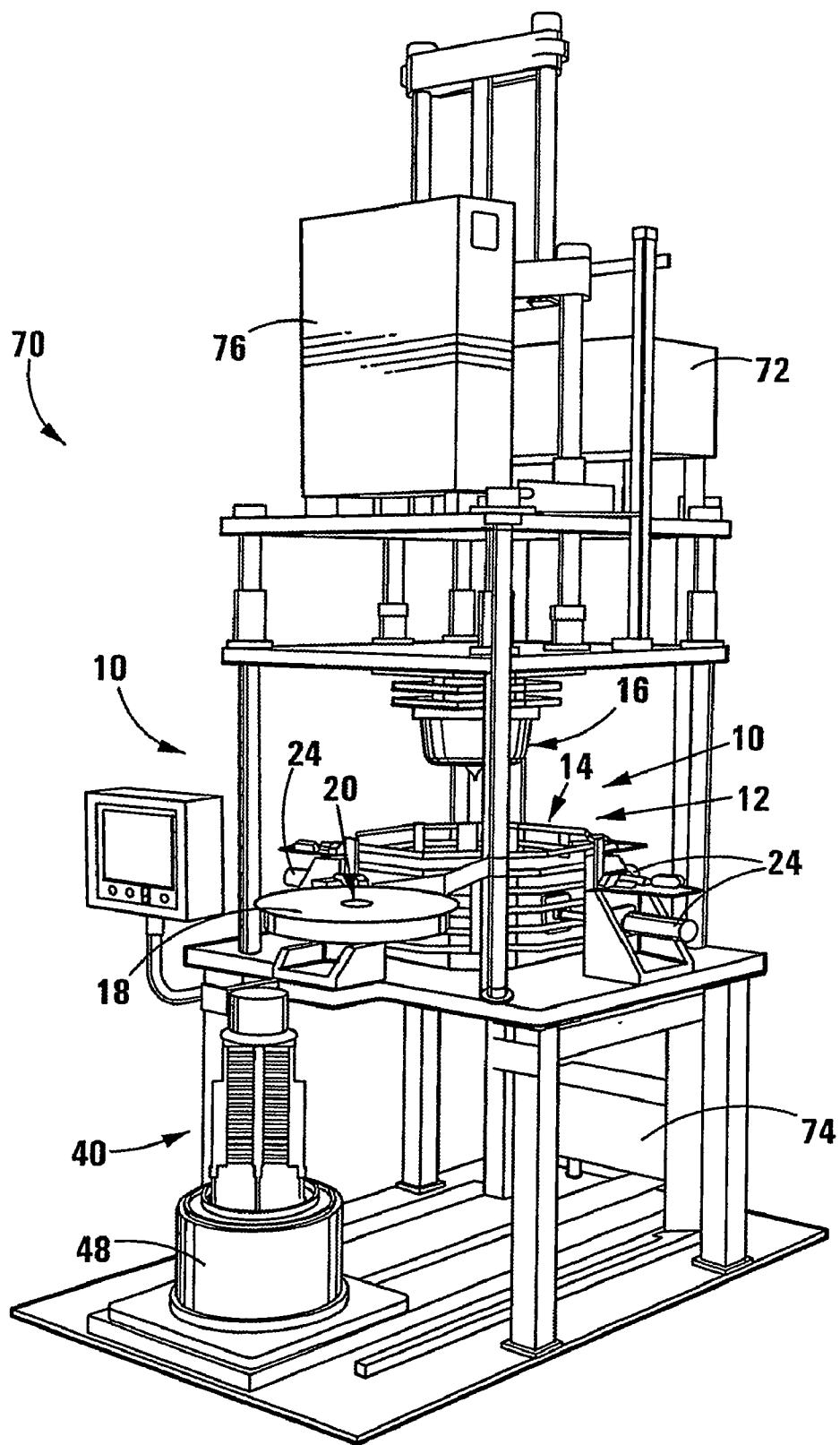

FIG 3

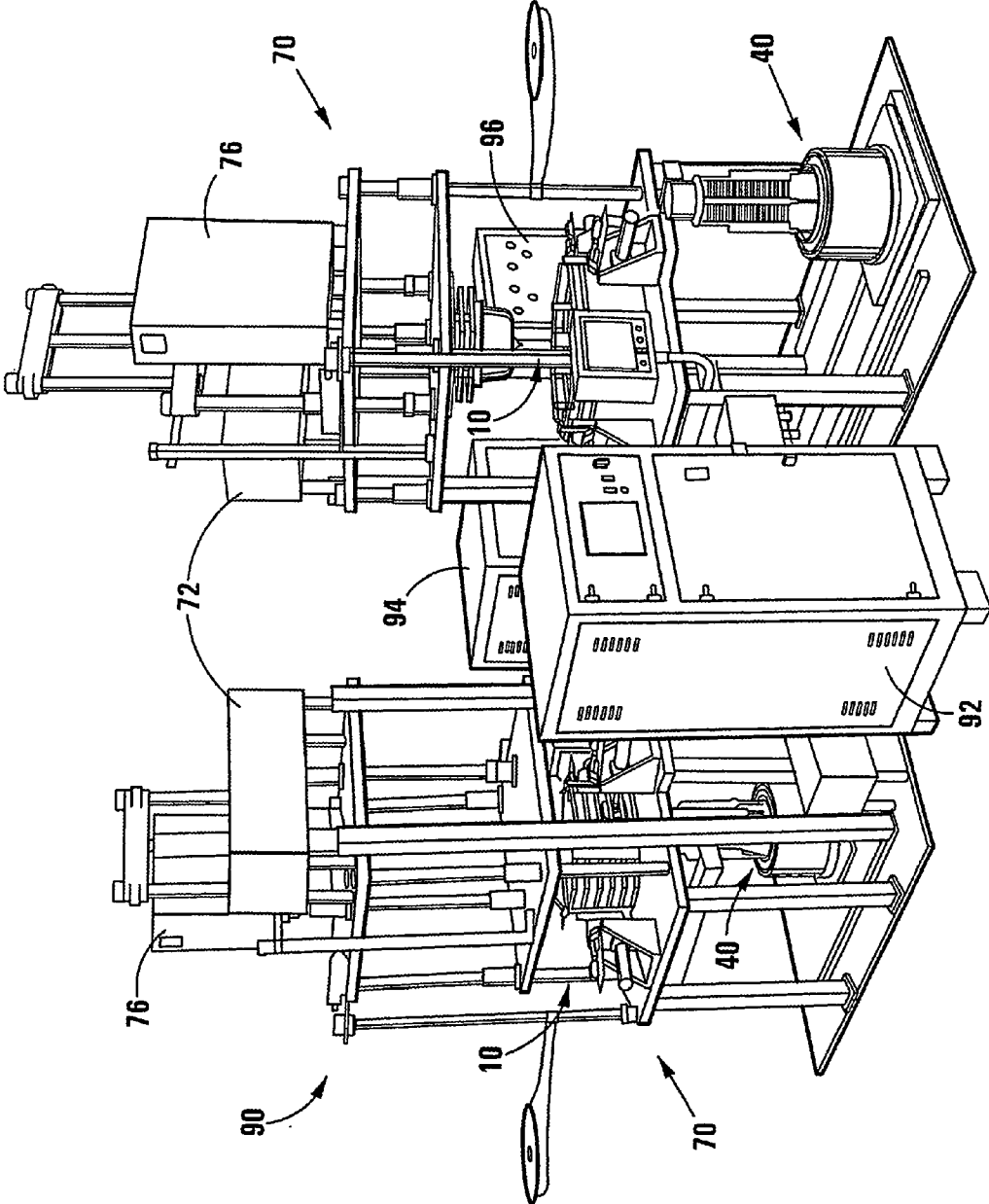

FIG 4

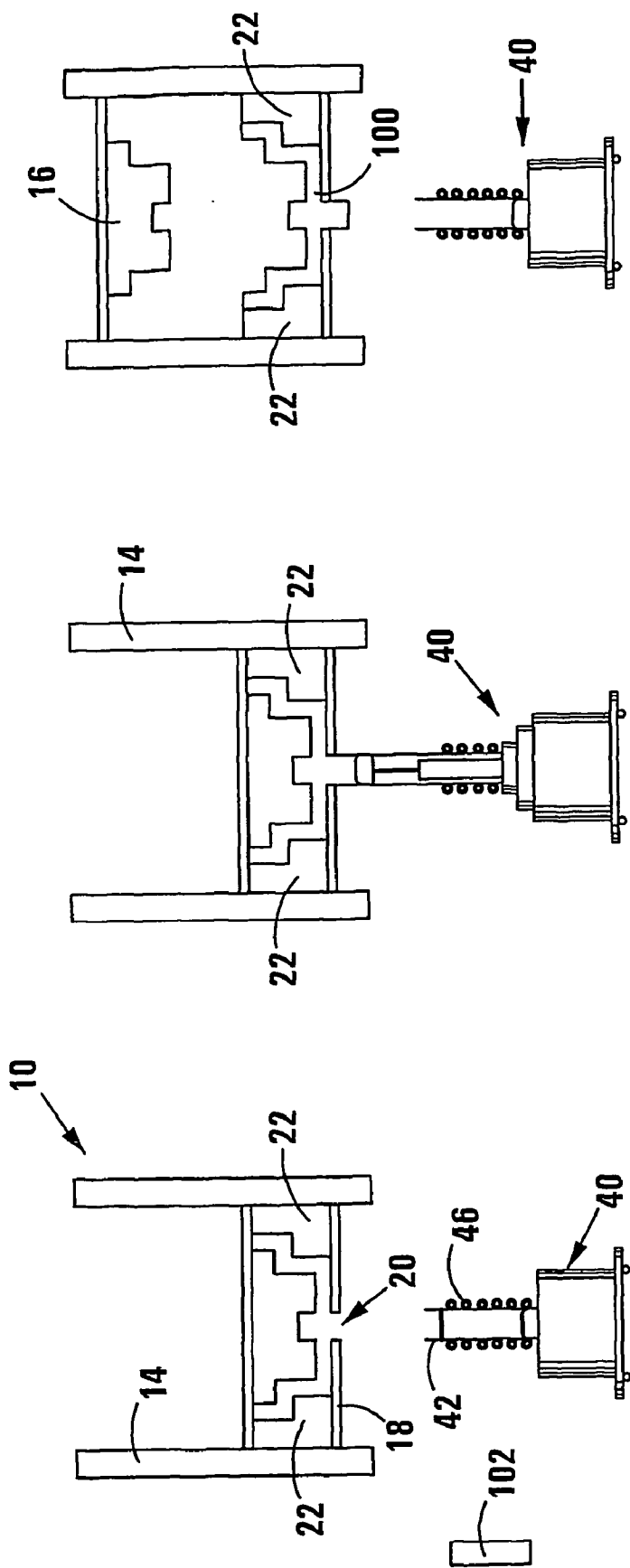

FIG 5

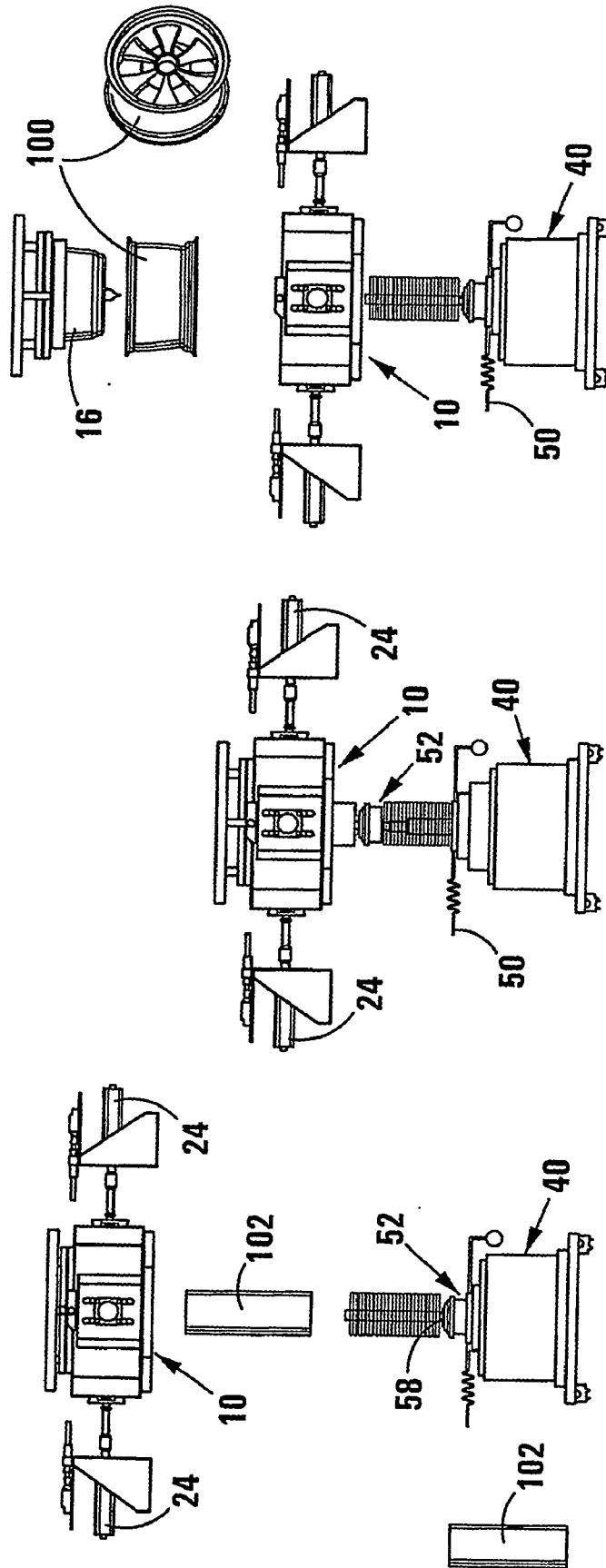

FIG 6

CASTING OF METAL ARTEFACTS

[0001] THIS INVENTION relates to the casting of a metal artefact. More particularly, the invention relates to a process for casting a metal artefact, to a casting assembly for casting metal artefacts, and to a casting apparatus or installation for casting a metal artefact, all being particularly suitable for casting light metal artefacts. As used herein, the term light metal encompasses both light metals as such, and alloys thereof in which one or more light metals form the major proportion of over 50% by mass, light metals being those having a density of less than 2.7 g/cm³. Light metals usually have low melting points of 660° C. or less.

[0002] According to a first aspect of the invention, there is provided a process for casting a metal artefact by charging a die or mould with molten metal and causing or allowing the metal to solidify in the die or mould to form the artefact, the process including the step, prior to charging the die or mould with the molten metal, of heating the die or mould by induction heating to an elevated temperature, the charging taking place with the die or mould at the elevated temperature.

[0003] The process may include the step of purging the die or mould, prior to the heating, so that casting of the artefact takes place under a desired atmosphere. Instead or in addition, the purging may be carried out during the heating of the die or mould. Thus, in other words, the process may include the step, prior to the charging of the die or mould, of purging the die or mould with a purging gas, the charging taking place under an atmosphere provided by the purging gas. Preferably, the purging is carried out both prior to and during the heating of the die or mould, the purging being discontinued before the charging takes place. The purging gas may be selected from the group consisting of argon, carbon dioxide and mixtures thereof. Instead said purging may be by means of a gas, such as sulphur hexafluoride (SF₆), which can act as a flux.

[0004] The process may include the step, prior to charging the die or mould with molten metal, of sealing off or locking the die or mould. In addition thereto, the process may include the step of disconnecting the supply of purging gas to the die or mould, prior to charging the die or mould with the molten metal. Typically, the supply of purging gas is discontinued when the die or mould attains its operating temperature. Charging the die or mould will typically be carried out to fill the die or mould to its full capacity.

[0005] The charging may be carried out under pressure, acting to fill the die or mould to its full capacity. In particular, and preferably, the filling of the die or mould with the molten charge is under an intermediate pressure, being neither what is known in the art as low pressure injection moulding nor what is known in the art as high pressure injection moulding. More particularly, the charging may be carried out by injection moulding, at an intermediate pressure in the range 50 KPa-30 MPa. It will be appreciated that routine experimentation can be employed to determine a desired or an optimum intermediate pressure under which the die or mould should be filled with the molten charge.

[0006] The process may include using, as the metal, a metal selected from the group consisting of aluminium, magnesium, lithium, zinc and alloys thereof. Preferably the process includes using, as the metal, a light metal selected from the group consisting of magnesium, aluminium and alloys thereof.

[0007] The process is expected to be useful, in particular, in the casting of light metal or alloy products selected from the group consisting of wheel rims, such as aluminium- or magnesium-alloy wheel rims, automotive gearbox casings, steering wheels, steering column housings, brake auxiliary parts or components, and automotive engine, marine and aircraft parts or components. Typically, the process will be used in the casting of aluminium- and magnesium-alloy wheel rims. Thus, the casting may be of a light metal artefact in the form of a motor vehicle wheel rim.

[0008] In particular, the process is expected to be useful in casting artefacts having cross-sectional thicknesses in the range 1.5-30 mm, usually 2-27 mm, with respective masses of 0.25-30 kg, usually 0.5-20 kg. In other words and more particularly, the casting may be of a metal artefact in which all parts of the solidified artefact are spaced from the closest part of the surface of the artefact by a spacing of 0.75-15 mm, the artefact having a mass of 0.25-30 kg.

[0009] Importantly, the process may include the step of providing the die or mould with a desired temperature profile, by selective application of the induction heating thereto, to promote solidification at desired rates of different parts of the molten light metal charged into the die or mould. Thus, the induction heating may be employed to provide the surface of the interior of the die or mould with a desired temperature profile whereby the interior surface of the die or mould has different parts or zones at different temperatures from each other or one another, in contact with the molten metal charged into the die or mould, thereby to promote desired cooling and solidification rates in different parts of the metal charged into the die or mould.

[0010] Charging the die or mould may be from a melting apparatus having a capacity to produce a full charge of molten metal which is matched in volume with the capacity or volume of the die or mould, the charging of the die or mould being with sufficient molten metal to produce a single artefact and the charging acting entirely to consume a full molten charge produced by the melting apparatus. Furthermore, charging the die or mould may be from a melting apparatus which is reciprocally movable relative to the die or mould, the process including reciprocally moving the melting apparatus between a charging position where it is charged with a precursor of the molten charge, and a filling position where the molten charge is transferred from the melting apparatus to the casting assembly. The casting may be carried out in a plurality of dies or moulds each associated with a single melting apparatus from which it is charged, each melting apparatus being associated with a single die or mould and being electrically heated by induction heating, a common electrical power supply being used to supply electrical power to the dies or moulds for the induction heating thereof, and a common electrical power supply being used to supply electrical power to the melting apparatuses. The process may be carried out by using a casting apparatus or installation as defined hereunder.

[0011] According to another aspect of the invention, there is provided a casting assembly for casting a metal artefact, the assembly including a die or mould for casting the artefact and including also an induction heating arrangement, the induction heating arrangement including at least one induction coil surrounding the die or mould, for heating the die or mould to an elevated temperature prior to the casting of the artefact.

[0012] The induction heating arrangement may be in the form of a variable-frequency induction heater.

[0013] The assembly may include a purging gas supply connected to the die or mould for supplying a purging gas to the interior of the die or mould.

[0014] The die or mould may be a disposable die, for example such as a sand casting die or mould. Instead, the die or mould may comprise a re-usable die or mould. The re-usable die or mould may be a metal die or mould, preferably a steel die or mould. In particular, the die or mould may be a re-usable multi-core segmented metal die or mould.

[0015] In the case of a re-usable die or mould, the die or mould may thus be a multi-core or segmented die or mould, comprising two or more cores or segments. In particular, the die or mould may comprise a top core or segment to which the solidified artefact remains removably attached at the end of the casting. The top core or segment may include or be associated with release means for releasing the artefact therefrom. In this case the die or mould will typically also comprise a bottom—or face core, and a ring of side cores associated with pistons, which side cores or segments give the die or mould its segmented character. In particular, the re-usable die or mould may be hydraulically operable, with regard to the pistons of the side cores and with regard to lifting of the top core and casting from the remaining cores to bring the casting into contact with pins forming the release means. The die or mould will typically have a charging opening for use in filling or charging the die or mould with molten light metal. In one embodiment of the invention, the die or mould has its charging opening provided through its bottom or face core for charging or filling the die or mould from below. In a preferred embodiment, the re-usable die or mould is hydraulically operable and has a bottom—or face core provided with a metal-charging opening for charging the die or mould with molten metal from below.

[0016] The induction heating arrangement may include two or more induction coils, operable independently of one another in achieving a desired temperature profile in the die or mould. In other words, the induction heating arrangement may include a plurality of at least two induction coils which are operable independently of each other or one another to heat the die or mould to said elevated temperature while providing the surface of the interior of the die or mould with a desired temperature profile.

[0017] The casting assembly may be of permanent construction as part of an installation, being constructed to remain more or less permanently in situ, at a production facility for casting light metal artefacts. Instead, and preferably, the casting assembly is not of permanent construction, being moveable as part of an apparatus from one said production facility to another.

[0018] The invention thus extends to a casting apparatus or installation for casting metal artefacts, the apparatus or installation including a casting assembly for casting a metal artefact as defined above, and a melting apparatus for forming a molten charge of metal for use in casting the metal artefact in the casting assembly, the melting apparatus including a heating arrangement for heating a precursor of the molten charge to a temperature at which the molten charge is formed from the precursor.

[0019] Preferably the melting apparatus is sized to melt charges of metal which are matched in size with the size of the die or mould, so that casting of the artefact in the die or mould consumes an entire charge. More particularly, the melting apparatus may have a capacity to produce a full charge of molten metal having a volume which is matched with the capacity or volume of the die or mould so that the casting of a single artefact in the die or mould entirely consumes a full molten charge produced by the melting apparatus when the melting apparatus is operated at full capacity.

[0020] The heating arrangement of the melting apparatus or installation may be an induction heating arrangement comprising at least one induction coil. In each case where the die or mould arrangement, on the one hand, and, the melting apparatus on the other hand, include one or more induction heating coils, the induction coils may be electrically connected to an electrical power supply therefor.

[0021] The melting apparatus may be reciprocally movable relative to the casting assembly between a charging position where charging of the melting apparatus with a precursor of the molten charge takes place, and a filling position where transfer of a molten charge from the melting apparatus or installation to the casting assembly takes place. Thus, the casting apparatus or installation may include rails, the melting apparatus being mounted via wheels on the rails, the wheels being rollable along the rails during reciprocating movement of the melting apparatus relative to the casting assembly.

[0022] The casting apparatus or installation may include two or more of the casting assemblies and the same number of the melting apparatuses, the casting assemblies sharing a common heating power supply and the melting apparatuses sharing a common heating power supply, for the casting of artefacts in respective casting cycles which are sufficiently out of phase to permit such sharing. In other words, the casting apparatus or installation may include a plurality of the casting assemblies and the same plurality of the melting apparatuses, each casting assembly being associated with a single said melting apparatus and each melting apparatus being associated with a single said casting assembly, the casting assemblies sharing a common electrical heating power supply and the melting apparatuses sharing a common electrical heating power supply.

[0023] The arrangement of the facility is particularly suitable for the case where the heating arrangement for the melting apparatuses or installations is also an induction heating arrangement, the heating power supplies being electrical power supplies.

[0024] The invention will now be described, by way of a non-limiting illustrative example, with reference to the accompanying diagrammatic drawings.

[0025] In the drawings,

[0026] FIG. 1 shows an exploded schematic side elevation of the various components of a casting assembly according to the invention for casting a light metal artefact in accordance with the process of the invention;

[0027] FIG. 2 shows an exploded schematic side elevation of the various components of a melting apparatus for use

with the casting assembly, for forming a molten charge of light metal, for use in the process of the invention;

[0028] FIG. 3 is a three-dimensional view of a casting apparatus or installation in accordance with the invention, for casting light metal artefacts, in accordance with the method of the invention;

[0029] FIG. 4 is a three-dimensional view of a casting facility according to the invention and comprising two casting apparatuses or installations of FIG. 3, for casting light metal artefacts in accordance with the method of the invention;

[0030] FIG. 5 shows a series of simplified schematic side elevations of the casting apparatus or installation of FIG. 3, illustrating the method of casting a light metal artefact in the form of a magnesium alloy wheel rim, in accordance with the invention, using the casting apparatus or installation of FIG. 3; and

[0031] FIG. 6 is another series of simplified schematic side elevation of the casting apparatus or installation of FIG. 3, further illustrating the method of casting a light metal artefact in the form of a magnesium alloy wheel rim illustrated by FIG. 5.

[0032] Referring first to FIG. 1 of the drawings, reference numeral 10 generally refers to a casting assembly for casting a light metal artefact, in accordance with the invention. The casting assembly 10 comprises a die or mould 12 for casting a light metal artefact in the form of a magnesium alloy wheel rim, and comprises also an induction heating arrangement 14 surrounding the die or mould 12.

[0033] The die or mould 12 is a multi-core or segmented re-useable steel die or mould, comprising a top core 16 to which a solidified artefact remains removably attached at the end of the casting process, a bottom—or face core 18 having a centrally located charging opening or passage 20 provided therethrough for charging or filling the die or mould 12 from below, and a segmented ring of four side cores 22 associated with respective pistons 24, the side cores 22 giving the die or mould 12 its segmented character. The die or mould 12 is hydraulically operated, with regard to the pistons 24 of the side cores 22 and with regard to lifting of the top core 16 and any attached light metal casting (not shown), upwardly and away from the remaining cores.

[0034] The top core 16 is associated with release means (not shown) for releasing the artefact therefrom at the end of the casting process.

[0035] The heating arrangement 14 comprises six windings respectively forming induction coils 25, 26, 27, 28, 29 and 30, operable independently of one another, for achieving a desired temperature profile in the die or mould 12.

[0036] The casting assembly 10 also includes a purging gas supply shown schematically by broken line 31, for supplying SF₆/CO₂ purging gas to the die or mould 12 prior to and during the casting process.

[0037] Referring now to FIG. 2 of the drawings, reference numeral 40 generally refers to a melting apparatus for forming a molten charge of light metal, in accordance with the invention. The melting apparatus or installation 40 comprises a hollow low carbon—or mild steel cylinder or sleeve 42 of circular cross-section for holding a molten

charge of light metal and also for facilitating heating of a precursor of the charge of light metal, an induction heating arrangement 44 comprising an induction coil 46 for heating contents of the cylinder or sleeve 42 to form a molten charge, and a molten metal transfer assembly 48 for transferring a molten charge of light metal from the cylinder or sleeve 42 to the die or mould 12 in which an artefact is cast.

[0038] The melting apparatus 40 also includes an inert gas supply 50 for supplying argon gas to the interior of the cylinder or sleeve 42 such that melting of the light metal charge takes place under a substantially inert atmosphere, and also to provide cooling to the lower end or base of the cylinder or sleeve 42 to form a secondary seal therefor as described hereunder.

[0039] In use, the induction coil 46 is mounted on the metal transfer assembly 48, the coil 46 being connected to the barrel 62 and surrounding the cylinder or sleeve 42 to heat the contents thereof.

[0040] The transfer assembly 48 comprises a telescopically moveable multi-stage piston arrangement 52 for use in elevating the cylinder or sleeve 42 to engage lockingly with the periphery of the charging opening 20 of the die or mould 12, prior to filling the die or mould 12 with a molten charge from the cylinder or sleeve 42. The multi-stage piston arrangement 52 incorporates a central piston comprising three telescopic piston rods 54, 55, 56 with the central rod 56 having a piston head 58 provided with a conical sealing surface 59 for sealingly engaging the periphery of the opening 20 into the die or mould 12 when an entire molten charge in the cylinder or sleeve 42 has been transferred from the cylinder or sleeve 42 into the die or mould 12. The multi-stage piston arrangement 52 includes a variable force and speed controller (not shown) for controlling the rate of movement thereof and also for controlling the upward force exerted by the piston head 58 on a molten charge in the cylinder or sleeve 42 and in the die or mould 12, when the piston head 58 sealingly engages the periphery of the charging opening 20 of the die or mould 12.

[0041] Thus, in use, the cylinder or sleeve 42 is supported on the transfer assembly 48, such that the multi-stage piston arrangement 52 is moveable within the interior of the cylinder or sleeve 42 in sliding and sufficiently sealing engagement therewith so as to enable a molten charge in the cylinder or sleeve 42 to be pushed upwardly and out of the cylinder or sleeve 42 upon the upward movement of the piston rods 54, 55, 56, to transfer and inject the molten charge into the die or mould 12.

[0042] The transfer assembly 48 also comprises a plurality of concentric barrels 60, 61, 62, 63 and 64 of different diameters. The barrels 60, 61, 62, 63 and 64 are telescopically vertically displaceable, relative to one another and nest in one another.

[0043] The barrel 60 is the bottom barrel and has wheels 66 for running on rails 67 forming part of the casting installation of FIGS. 4-6 for reciprocating the melting apparatus or installation 40 between a charging position where charging of the cylinder or sleeve 42 with a precursor of a molten charge takes place, and a filling position where the melting apparatus 40 is in alignment with the charging opening 20 of the die or mould 12 of the casting assembly 10, to enable a molten charge formed by melting of a

precursor thereof in the cylinder or sleeve 42 to be transferred therefrom into said die or mould 12, thereby typically filling it with the molten charge. The barrel 64 is the top barrel and provides a circumferentially extending upwardly facing support ring having a groove (not shown) for sealingly engaging the lower end of the cylinder or sleeve 42 therein. The barrel 62 in turn provides a circumferentially extending upwardly facing support ring on which the induction coil 46 is supported when placed over the cylinder or sleeve 42 to surround it.

[0044] In addition to the seal provided by the groove on the barrel 64, the argon gas supplied via the gas supply 50 provides cooling to the lower end of the cylinder or sleeve 42 during melting of the precursor of the molten charge, allowing part of the molten charge formed to solidify in a zone between the piston arrangement 52 and the top barrel 64 and at the lower end of the cylinder or sleeve 42, thereby providing a secondary seal which is formed of solidified light metal from the molten charge.

[0045] Referring now to FIG. 3 of the drawings, reference numeral 70 generally refers to a casting apparatus of installation for casting light metal artefacts, in accordance with the invention. The same parts are assigned the same reference numerals as in FIGS. 1 and 2, unless otherwise specified.

[0046] The casting apparatus or installation 70 comprises a casting assembly 10 as described above and a melting apparatus 40 also as described above. The casting apparatus or installation 70 also includes a die or mould hydraulic controller 72 and a melting apparatus 40 hydraulic controller 74.

[0047] The top core 16 is associated with release means (not shown) for releasing the artefact therefrom at the end of the casting process.

[0048] The casting apparatus or installation 70 also includes a central processing unit (CPU) 76 for monitoring the heating of the induction heating arrangement 14 to achieve the desired temperature profile, and also for providing feedback control to respective power supplies 92 and 94 (FIG. 4) therefor.

[0049] The casting apparatus or installation 70 also includes rails (not shown but see 67 in FIG. 2) on which the wheels 66 of the metal transfer assembly 48 of the melting apparatus 40 can run. Thus, the melting apparatus 40 is reciprocable relative to the die arrangement 12 between a charging position (as shown in FIG. 3) where charging of the melting apparatus 40 with a precursor of the molten charge takes place, and a filling position (see FIGS. 5 and 6) where transfer of a molten charge from the melting apparatus 40 to the die or mould 12 of the casting assembly 10 takes place.

[0050] Referring now to FIG. 4 of the drawings, reference numeral 90 generally refers to a development of the apparatus or installation 70 in the form of a casting facility. The casting facility 90 comprises two casting apparatuses or installations 70, each comprising a casting assembly 10 having a die or mould 12 in which the casting of the artefact is carried out, and having a melting apparatus 40 for induction melting a charge of light metal. The casting facility 90 also includes a melt induction heating power supply 92, for example of 100 kW, for separately supplying power to each of the two melting apparatuses 40, a die induction heating power supply 94, also for example of 100 kW, for separately supplying power to each casting assem-

bly 10, a cooling tower (not shown) for providing cooling fluid, and a gas supply control unit 96 for supplying purging gases to the casting assembly 10 and also to the melting apparatuses 40.

[0051] It will be appreciated that the casting facility 90 permits two artefacts to be cast simultaneously using casting cycles which are out of phase, the melting apparatuses 40 sharing the common induction heating power supply 92 and the casting facilities 10 sharing the common induction heating power supply 94. The casting of the artefacts then takes place in respective casting cycles which are sufficiently out of phase to permit such sharing. It will thus be appreciated that the casting facility 90 can be operated in quasi-continuous fashion, in that the casting apparatuses or installations 70 can be used on an alternating basis, with the one having its melting apparatus 40 in its filling position and being used for casting while the other has its melting apparatus 40 in its charging position and is charged with a precursor of the light metal, and being prepared to be reciprocated to its filling position, as soon as the casting process in the other casting apparatus or installation 70 is completed.

[0052] Referring now to FIGS. 5 and 6 of the drawings, use of the casting apparatus or installation 70 described above is illustrated with reference to casting a light metal artefact in the form of a magnesium alloy wheel rim 100, using a precursor in the form of a pre-formed billet or ingot 102 of a magnesium-aluminium-zinc alloy known in the art as AZ91. The billet or ingot 102 is placed on the piston arrangement 52, with the associated melting apparatus or 40 in its charging position. The cylinder or sleeve 42 is placed over the billet or ingot 102, such that the lower end of the cylinder or sleeve 42 sealingly engages said groove on the top barrel 64 of the metal transfer assembly 48. The induction coil 46 is connected to the barrel 62 of the metal transfer assembly 48, so that placing the cylinder or sleeve 42 and the billet or ingot 102 in position, acts to have them surrounded by the coil 46.

[0053] The casting assembly 10 is prepared for casting by lowering the top core 16 such that it engages with the bottom- or face core 18. The ring of side core segments are then placed in position, using their pistons 24, to close the die. Purging gas in the form of SF₆/CO₂ fluxing gas mixture comprising 0.2% by volume SF₆ is fed into the die or mould 12 and the die or mould 12 is heated using the induction coils 25, 26, 27, 28, 29 and 30 by electrical power fed from the induction heating power supply 94 using a pre-selected frequency, until the die or mould 12 achieves a required operating temperature, and has a desired temperature profile. The rate of heating can be altered by changing the power input from the power supply 94 and/or by changing the frequency thereof, with a higher frequency resulting in a higher heating rate; and the coils 25, 26, 27, 28, 29 and 30 can be selectively operated with different power supplies thereto, to achieve said temperature profile.

[0054] The melting apparatus 40 is reciprocated with the aid of the wheels 66 on the rails 67 of the casting apparatus or installation 70, from the charging position where charging of the cylinder or sleeve 42 with the billet or ingot 102 of a molten charge of AZ91 alloy takes place, to a filling position where the melting apparatus 40 is in alignment with the charging opening 20 through the bottom—or face core 18 of the die or mould 12. The cylinder or sleeve 42 is sealingly engaged with the lower surface of the bottom—or face core 18, by raising the barrel 64 hydraulically, which also seals

the cylinder or sleeve 42 to the barrel 64. The cylinder or sleeve 42 is purged by a SF₆/CO₂ purging gas. The billet or ingot 102 is melted under an atmosphere provided by the purging gas introduced to the cylinder or sleeve 42 by the gas supply 50, until a molten charge of AZ91 alloy is formed. Argon is then used to provide a cooling atmosphere for cooling of the molten charge at the lower end of the cylinder or sleeve 42 to form a secondary seal in the form of a more or less semi-solid or solidified portion or sprue of the light metal (not shown).

[0055] Once the desired operating temperature and temperature profile have been achieved in the die or mould 12, and the die or mould 12 has been pressure locked with the aid of the pistons 24 by means of the hydraulic controller 72, the gas supply to the cylinder or sleeve 42 is cut off and the molten charge is transferred under pressure from the cylinder or sleeve 42 into the die or mould 12 by means of the piston arrangement 52, thereby filling the die or mould 12 with the molten charge. Prior to and during injection of the molten charge into the die or mould 12, the die or mould 12 is purged with the abovementioned SF₆/CO₂ purging/fluxing gas by means of gas supply control unit 96, which gas also protects the molten surface off the molten charge both in the sleeve 42 and when it enters the die or mould 12. The piston head 58 locks sealingly against the periphery of the charging opening 20 and partially enters the charging opening 20 to increase the pressure on the molten charge in the die or mould 12. The die or mould 12 is allowed to cool down and the melting apparatus 40 is disengaged from the die or mould 12. The melting apparatus 40 is then reciprocated back to its charging position.

[0056] The die or mould 12 is then opened by hydraulically disengaging the ring of side core segments 22 from one another with the aid of the pistons 24, and the top core 16 with the solidified wheel rim 100 attached thereto, is lifted, using the controller 72. The wheel rim 100 is then detached or released from the top core 16 by allowing downwardly directed pins forming part of the release means (not shown) to push the wheel rim 100 downwardly during the raising of the top core 16.

[0057] The piston arrangement 52 is lowered and then the barrels of the assembly 20 are retracted, releasing the cylinder or sleeve 42 and the solidified portion or sprue (not shown) of the molten charge which formed the secondary seal for the cylinder or sleeve 42. The used cylinder or sleeve 42 is then cleaned and re-positioned back on the transfer assembly 48 in preparation for the casting of a new wheel rim 100. It will be appreciated, however, that a different cylinder or sleeve 42 may instead be used to avoid waste of production time and also to minimise the possibility of cross-contamination.

[0058] It is an advantage of the invention that the casting apparatus or installation 70 need not necessarily to be of a permanent construction, being moveable from one production facility to another with ease. Thus the casting apparatus or installation 70 may be inexpensively set up close to an end user of the artefacts to be cast, thereby reducing transportation costs, and the like.

[0059] It is also a further particular advantage of the invention that the induction heating of the die or mould 12 by the heating arrangement comprising the six induction coils 25, 26, 27, 28, 29 and 30, operable independently of one another, enables a desired temperature profile to be obtained in the die or mould 12, prior to the casting step, thereby having a desirable consequential effect on the solidi-

fication rate of the various portions of the artefact, such as the wheel rim 100, thereby reducing stresses in the solidified artefact (wheel rim 100). The attainment of desired flow distances for complete filling of the die or mould 12 are also permitted.

[0060] It is yet a further advantage of the present invention that the casting apparatus or installation 70 does not require much space for it to be erected. For example, the casting apparatus or installation 70 as described above only requires a floor space of about 20-30 m². The present process also offers other costs benefits such as the fact that power supply only has to be fed to the casting apparatus or installation 70 immediately prior to casting and can be switched off at the end of casting a single artefact, without adversely affecting the process or the efficiencies thereof. In the case of a power failure during the casting process using the method and casting apparatus or installation 70 of the present invention, it will be appreciated that losses need be no greater than loss of the molten charge in the cylinder or sleeve 42, comprising the single billet or ingot 102, as compared to a typical foundry where the process is continuous and large amounts of metal have to be molten at any given point in time, all of which can solidify in the event of a power failure. Indeed, losses can in principle be avoided completely by simply re-melting the contents of the cylinder or sleeve 42, when the power supply is restored.

[0061] It is a yet a further advantage of the process in accordance with the present invention, that the die or mould 12 of the casting assembly 10 does not require running-in in order to achieve the optimum process conditions. The desired casting temperature profile may be easily obtained by selectively controlling power fed to each of the coils 25, 26, 27, 28, 29 and 30. The fact that the process does not require a running-in cycle or cycles means that a particular number of billets or ingots 102, barring any power failures, should yield an equivalent number of wheel rims 100, with reduced wastage arising from reject artefacts and enhanced quality control.

1. A process for casting a metal artefact by charging a die or mould with molten metal and causing or allowing the metal to solidify in the die or mould to form the artefact, the process being characterized in that it includes the step, prior to charging the die or mould with the molten metal, of heating the die or mould by induction heating to an elevated temperature, the charging taking place with the die or mould at the elevated temperature.

2. A process as claimed in claim 1, characterized in that it includes the step, prior to the charging of the die or mould, of purging the die or mould with a purging gas, the charging taking place under an atmosphere provided by the purging gas.

3. A process as claimed in claim 2, characterized in that the purging is carried out both prior to and during the heating of the die or mould, the purging being discontinued before the charging takes place.

4. A process as claimed in any one of the preceding claims, characterized in that the charging is carried out under pressure, acting to fill the die or mould to its full capacity.

5. A process as claimed in claim 4, characterized in that the charging is carried out by injection moulding, at an intermediate pressure in the range 50 KPa-30 MPa.

6. A process as claimed in any one of the preceding claims, characterized in that it includes using, as the metal, a metal selected from the group consisting of aluminium, magnesium, lithium, zinc and alloys thereof.

7. A process as claimed in claim 6, characterized in that it includes using, as the metal, a light metal selected from the group consisting of magnesium, aluminium and alloys thereof.

8. A process as claimed in any claim 7, characterized in that the casting is of a light metal artefact in the form of a motor vehicle wheel rim.

9. A process as claimed in any one of the preceding claims, characterized in that the casting is of a metal artefact in which all parts of the solidified artefact are spaced from the closest part of the surface of the artefact by a spacing of 0.75-15 mm, the artefact having a mass of 0.25-30 kg.

10. A process as claimed in any one of the preceding claims, characterized in that the induction heating is employed to provide the surface of the interior of the die or mould with a desired temperature profile whereby the interior surface of the die or mould has different parts or zones at different temperatures from each other or one another, in contact with the molten metal charged into the die or mould, thereby to promote desired cooling and solidification rates in different parts of the metal charged into the die or mould.

11. A process as claimed in any one of the preceding claims, characterized in that charging the die or mould is from a melting apparatus having a capacity to produce a full charge of molten metal which is matched in volume with the capacity or volume of the die or mould, the charging of the die or mould being with sufficient molten metal to produce a single artefact and the charging acting entirely to consume a full molten charge produced by the melting apparatus.

12. A process as claimed in any one of the preceding claims, characterized in that the charging of the die or mould is from a melting apparatus which is reciprocally movable relative to the die or mould, the process including reciprocally moving the melting apparatus between a charging position where it is charged with a precursor of the molten charge, and a filling position where the molten charge is transferred from the melting apparatus to the casting assembly.

13. A process as claimed in any one of the preceding claims, characterized in that the casting is carried out in a plurality of dies or moulds, each associated with a single melting apparatus from which it is charged, each melting apparatus being associated with a single die or mould and being electrically heated by induction heating, a common electrical power supply being used to supply electrical power to the dies or moulds for the induction heating thereof, and a common electrical power supply being used to supply electrical power to the melting apparatuses.

14. A casting assembly (10) for casting a metal artefact (100), the assembly including a die or mould (12) for casting the artefact and the assembly being characterized in that it includes an induction heating arrangement (14), the induction heating arrangement including at least one induction coil (25, 26, 27, 28, 29, 30) surrounding the die or mould, for heating the die or mould to an elevated temperature prior to the casting of the artefact.

15. An assembly as claimed in claim 14, characterized in that the induction heating arrangement is in the form of a variable-frequency induction heater (16).

16. An assembly as claimed in claim 14 or claim 15, which includes a purging gas supply line (31) connected to the die or mould for supplying a purging gas to the interior of the die or mould.

17. An assembly as claimed in any one of claims 14-16 inclusive, characterized in that the die or mould is a re-usable multi-core segmented metal die or mould.

18. An assembly as claimed in claim 17, characterized in that the re-usable die or mould is hydraulically operable and has a bottom- or face core provided with a metal-charging opening for charging the die or mould with molten metal from below.

19. An assembly as claimed in any one of claims 14-18 inclusive, in which the induction heating arrangement includes a plurality of at least two induction coils which are operable independently of each other or one another to heat the die or mould to said elevated temperature while providing the surface of the interior of the die or mould with a desired temperature profile.

20. A casting apparatus or installation for casting metal artefacts, the apparatus being characterized in that it includes a casting assembly (10) as claimed in claim 14, and a melting apparatus (40) for forming a molten charge of metal for use in the casting of a metal artefact in the casting assembly, the melting apparatus including a heating arrangement (44) for heating a precursor of the molten charge to a temperature at which the molten charge is formed from the precursor.

21. An apparatus or installation as claimed in claim 20, characterized in that the melting apparatus has a capacity to produce a full charge of molten metal having a volume which is matched with the capacity or volume of the die or mould so that the casting of a single artefact in the die or mould entirely consumes a full molten charge produced by the melting apparatus when the melting apparatus is operated at full capacity.

22. An apparatus or installation as claimed in claim 20 or claim 21, characterized in that the heating arrangement of the melting apparatus is an induction heating arrangement comprising at least one induction coil (46).

23. An apparatus or installation as claimed in any one of claims 20-22 inclusive, characterized in that the melting apparatus is reciprocally movable relative to the casting assembly between a charging position where charging of the melting apparatus with a precursor of the molten charge takes place, and a filling position where transfer of a molten charge from the melting apparatus to the casting assembly takes place.

24. An apparatus or installation as claimed in claim 23, characterized in that it includes rails (67), the melting apparatus being mounted via wheels (66) on the rails, the wheels being rollable along the rails during reciprocating movement of the melting apparatus relative to the casting assembly.

25. An apparatus or installation as claimed in any one of claims 20-24 inclusive, characterized in that it includes a plurality of the casting assemblies and the same plurality of the melting apparatuses, each casting assembly being associated with a single said melting apparatus and each melting apparatus being associated with a single said casting assembly, the casting assemblies sharing a common electrical heating power supply (94) and the melting apparatuses sharing a common electrical heating power supply (92).