

No. 794,524.

PATENTED JULY 11, 1905.

H. LOBEL.
DOOR HANGER.

APPLICATION FILED OCT. 27, 1904.

2 SHEETS—SHEET 1.

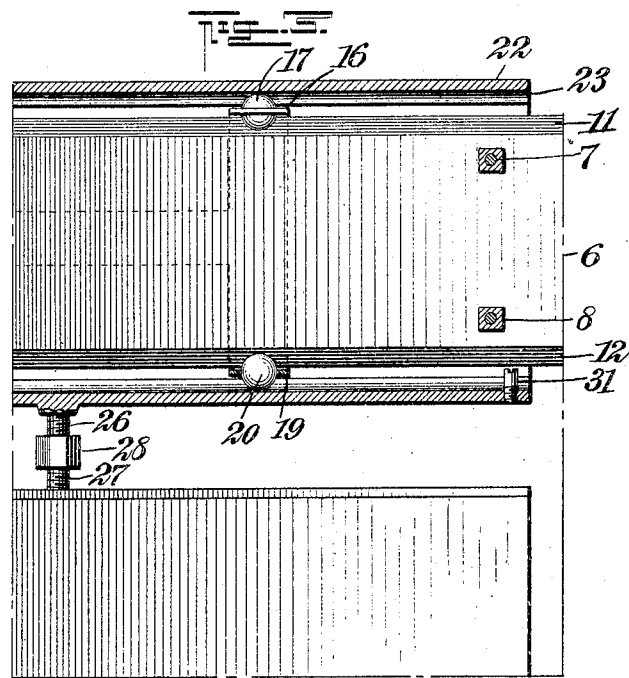
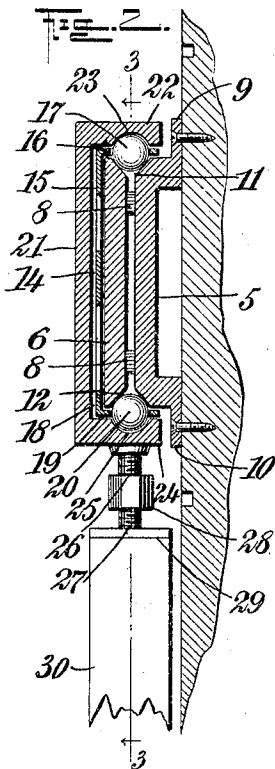
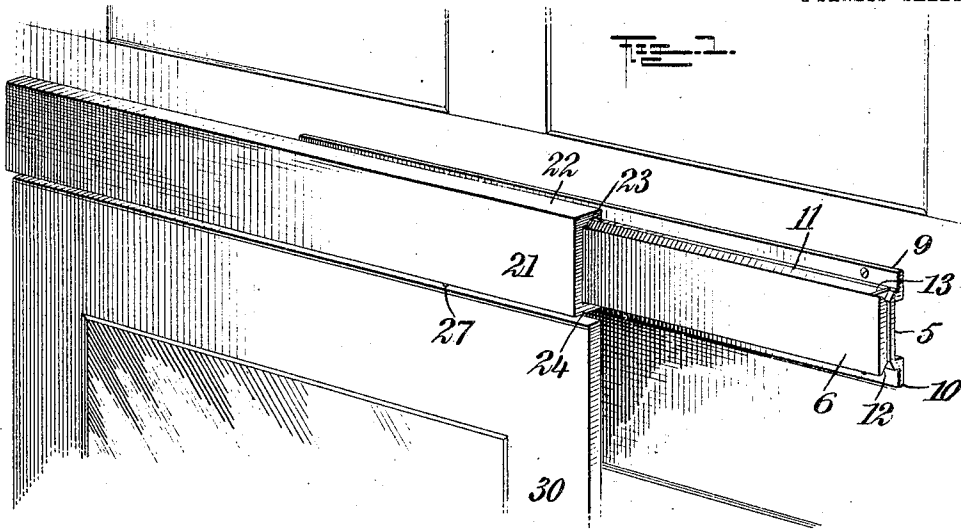

WITNESSES:

John C. Cheney
C. R. Ferguson

INVENTOR

Herman Lobel

BY *Munn*

ATTORNEYS

H. LOBEL.
DOOR HANGER.

APPLICATION FILED OCT. 27, 1904.

2 SHEETS—SHEET 2.

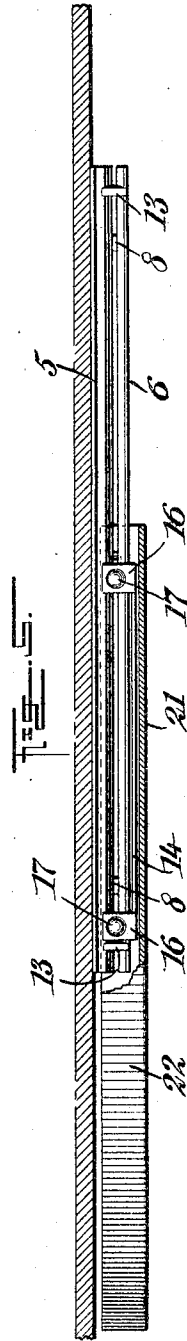
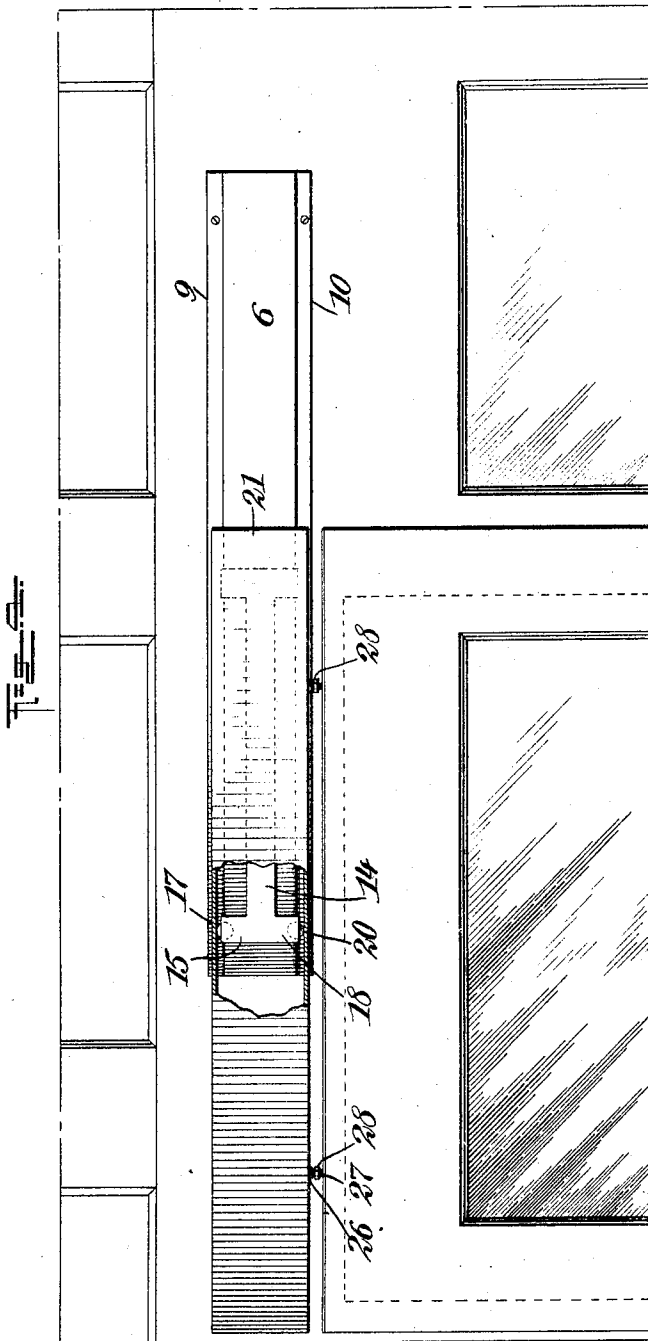

WITNESSES:

E. P. Colburn
C. R. Ferguson

INVENTOR

Herman Lobel

BY *Munn*

ATTORNEYS

UNITED STATES PATENT OFFICE.

HERMAN LOBEL, OF NEW YORK, N. Y.

DOOR-HANGER.

SPECIFICATION forming part of Letters Patent No. 794,524, dated July 11, 1905.

Application filed October 27, 1904. Serial No. 230,172.

To all whom it may concern:

Be it known that I, HERMAN LOBEL, a citizen of the United States, and a resident of the city of New York, borough of Manhattan, in the county and State of New York, have invented a new and Improved Door-Hanger, of which the following is a full, clear, and exact description.

This invention relates to improvements in hangers for sliding doors, the object being to provide a hanger of simple construction and having means for so suspending a door that it will hang in direct downward alinement with the slide-bearings, thus preventing any vertical turning strain on the sliding member, and therefore permitting an easy sliding movement of the door.

Other objects of the invention will appear in the general description.

I will describe a door-hanger embodying my invention and then point out the novel features in the appended claims.

Reference is to be had to the accompanying drawings, forming a part of this specification, in which similar characters of reference indicate corresponding parts in all the figures.

Figure 1 is a perspective view of a door-hanger embodying my invention and illustrating a door suspended therefrom. Fig. 2 is a vertical cross-section thereof. Fig. 3 is a longitudinal section on the line 3 3 of Fig. 2. Fig. 4 is a front elevation partly broken away and in section, and Fig. 5 is a sectional plan with a portion of the sliding member removed.

The hanger comprises a fixed member designed to be secured to a door-casing and over the door. This fixed member consists of an inner plate 5 and an outer plate 6, these plates being secured together by bolts 7, which pass through spacing-blocks 8. These spacing-blocks hold the adjacent surfaces of the plates a slight distance apart from the top to the bottom, so that dirt or dust may readily pass downward between the plates, preventing its accumulation in the upper ball-raceway, to be hereinafter described. The inner plate 5 is provided with an upper flange 9 and a lower flange 10, and fastening-screws pass

through these flanges into the casing. The upper inner edges of the plates are beveled downward and inward, as indicated at 11, forming a substantially V-shaped raceway, and the lower edges are beveled inward and upward, as indicated at 12, to also form a lower raceway, which is substantially V-shaped. At the ends of the upper raceway are stop-blocks 13.

Supported on the fixed member and movable longitudinally thereof is a carriage consisting of a bar 14, which extends along the front side of the plate 6, and on the ends of this bar 14 are upwardly-extended arms 15, which have inwardly-turned portions 16 extended over the top of the plates 5 and 6, and these inwardly-turned portions are provided with openings to receive the antifriction-balls 17, which run in the upper raceway. The bar 14 also has at its ends downwardly-extended arms 18, provided with portions 19 projected underneath the fixed member and provided with openings to receive the antifriction-balls 20, which run in the lower raceway. It will be noted that the carriage carrying the balls is much shorter than the fixed member.

Mounted on the carriage is a sliding member, consisting of a front plate 21, having an inwardly-extended flange 22 at its upper edge, which projects over the upper side of the fixed member and is provided with a longitudinal raceway 23 for receiving the upper balls 17. The lower edge of the plate 21 is provided with an inwardly-extended flange 24, having a raceway 25 for receiving the lower balls 20.

Extended downward from the flange 24 near each end are bolts 26 27, one of each pair of bolts having a left-hand thread, while the other bolt of the pair has a right-hand thread, and the bolts of a pair are connected by an adjusting-nut 28, and as the lower bolts are connected to a plate 29, secured to the upper edge of the door 30, it is obvious that the door may be readily trued up or leveled by manipulating the nuts 28. As the axes of the suspending-bolts are in direct vertical alinement with the centers of the bearing-balls and as said bolts are connected directly in the transverse

center of the door it is apparent that the door will at all times hang plumb and will have no tendency to impart torsional or bending strain on the sliding member. The upper flange 22
 5 by being extended over the space between the fixed-member plates will prevent the passing of dirt downward between the plates to lodge in the lower raceway.

In the operation when the door with the
 10 sliding member moves in one direction the carriage will also move in the same direction on the fixed member. When the end of the carriage engages with the stop 13, the carriage will be held stationary; but the door will
 15 have a still further sliding movement relatively to the carriage. When the door is moved in the opposite direction, an inwardly-extended lug 31 at the end of the bottom flange will engage with the carriage and move it
 20 along with the sliding member, it being understood that the carriage remains stationary until it is reached by the lug. By employing upper and lower sets of balls and raceways the door will be prevented from swinging out-
 25 ward.

Having thus described my invention, I claim as new and desire to secure by Letters Patent—

1. A door-hanger comprising a fixed member having longitudinal raceways in its upper
 30 and lower edges, a carriage, balls movable with the carriage and engaging said raceways, and a sliding member having upper and lower raceways for receiving said balls.

2. In a door-hanger, the combination with
 35 a sliding member, of a fixed member consisting of a plurality of plates secured together

and spaced apart, and on which said sliding member moves.

3. In a door-hanger, the combination with a sliding member, of a fixed member consisting of a pair of plates, blocks arranged between the plates for spacing them apart, the upper and lower inner edges of the plates being beveled to form raceways, a carriage, bearing-balls mounted in the carriage and engaging in said raceways, and a sliding member having an inwardly-extended upper flange provided with a raceway for receiving the upper balls, and an inwardly-extended bottom flange for receiving the lower balls.

4. A door-hanger comprising a fixed member consisting of spaced plates having a raceway at the top and a raceway at the bottom, a carriage comprising a bar extended along said plates and having upper and lower inwardly-extended portions at the ends provided with openings, bearing-balls for engaging in said openings and in the raceways, stops near the ends of said raceways, a sliding bar having an inwardly-extended top flange provided with a raceway for receiving the upper balls, and an inwardly-extended bottom flange provided with a raceway for receiving the lower balls, and door-suspending devices depending from said sliding member.

In testimony whereof I have signed my name to this specification in the presence of two subscribing witnesses.

HERMAN LOBEL.

Witnesses:

JNO. M. RITTER,
 C. R. FERGUSON.