

19



Europäisches Patentamt
European Patent Office
Office européen des brevets



11 Publication number: **0 587 185 A2**

12

EUROPEAN PATENT APPLICATION

21 Application number: **93114601.3**

51 Int. Cl.⁵: **B01F 7/18, B01F 3/12,
B02C 17/16**

22 Date of filing: **10.09.93**

30 Priority: **11.09.92 JP 269401/92
18.03.93 JP 58829/93**

43 Date of publication of application:
16.03.94 Bulletin 94/11

84 Designated Contracting States:
DE FR GB

71 Applicant: **TOYO INK MANUFACTURING CO.,
LTD.
3-13, Kyobashi 2-chome
Chuo-ku, Tokyo 104(JP)**

72 Inventor: **Murase, Yasuhiko
3-13, Kyobashi 2-chome,
Chuo-ku
Tokyo(JP)**
Inventor: **Mizoguchi, Naoji
3-13, Kyobashi 2-chome,
Chuo-ku
Tokyo(JP)**
Inventor: **Yoshida, Fumio
3-13, Kyobashi 2-chome,
Chuo-ku
Tokyo(JP)**
Inventor: **Kanai, Kouichi
3-13, Kyobashi 2-chome,
Chuo-ku
Tokyo(JP)**

74 Representative: **Solf, Alexander, Dr. et al
Dr. Solf & Zapf
Zeppelinstrasse 53
D-81669 München (DE)**

54 **Continuous dispersing apparatus.**

57 A continuous dispersing apparatus in which stirring vanes in a vessel disperse pulverized media, wherein mill base containing coarse pigment particles is prevented from being discharged. The apparatus includes a vessel for containing pulverized media with a supply inlet and a discharge outlet being formed at respective ends of the vessel, a rotating disc mounted on a rotating shaft passing through the vessel, and a partition defining a gap which prevents the passage of the pulverized media while passing dispersed material, the partition dividing the vessel into a plurality of chambers. Each chamber is provided with at least one stirring device mounted on the rotating shaft.

EP 0 587 185 A2

BACKGROUND OF THE INVENTION

The invention relates to a continuous dispersing apparatus in which stirring vanes in a vessel disperse pulverized media.

In producing printing ink, paint or the like, a mill base is used, which is formed by dispersing a powdered pigment in a varnish, a solvent or the like at a high concentration. In the dispersing process, a powdered pigment composed of secondary particles formed by agglutinating primary particles of the pigment is pulverized and dispersed in a varnish to produce fine particles not containing coarse particles. Such process is employed to improve the tinting strength of the printing ink and the paint.

To perform the above process, dispersing apparatuses such as a sand mill, a grain mill, a ball mill and the like are known. Dispersing apparatuses capable of preparing printing ink, *etc.*, continuously are designed to continuously supply a mill base material from a material supply inlet that communicates with a vessel, a dispersing process is performed in the vessel, and thereafter the dispersed mill base is discharged continuously from a discharge outlet. However, since the supplied mill base material is not dispersed uniformly in the vessel, so-called "short-pass" occurs whereby mill base containing coarse pigment particles is discharged from the discharge outlet.

The problem of short pass can be prevented to a certain degree by increasing the rate of loading of pulverized media. However, too high a rate of loading of the media induces choking, which results in an uneven distribution of the media on the discharge outlet side, thereby leading to unstable operation of the apparatus. To avoid this problem, the apparatus is operated at a rate of loading of the pulverized media of about 75 to 80%.

SUMMARY OF THE INVENTION

In order to solve the above problems encountered by the conventional continuous dispersing apparatus, an object of the invention is to provide an economically advantageous continuous dispersing apparatus with high pulverizing and dispersing efficiency.

The invention is applied to a continuous dispersing apparatus that comprises a vessel for containing pulverized media; a supply inlet and a discharge outlet formed at respective ends of the vessel, a rotating disc mounted on a rotating shaft passing through the vessel, a partition defining a gap which prevents the passage of the pulverized media while passing dispersed material, wherein the partition divides the vessel into a plurality of chambers, each chamber having at least one stir-

ring means mounted on the rotating shaft.

BRIEF DESCRIPTION OF THE DRAWINGS

The accompanying drawings illustrate the presently preferred embodiment of the invention and, together with the detailed description of the preferred embodiments provided below, explain the features of the invention, wherein:

Fig. 1 is a front sectional view of a continuous dispersing apparatus, which is an embodiment of the invention; and

Fig. 2 is a sectional view taken along a long A-A' of Fig. 1.

DESCRIPTION OF PREFERRED EMBODIMENTS

The invention will be described with reference to the drawings.

A continuous dispersing apparatus of the invention has a vessel 10 and a rotating shaft 15 that passes through the vessel 10 via at least one end surface of the vessel 10. While a cylindrical-shaped vessel 10 is shown in the drawings, the section of the vessel may be rectangular, hexagonal, octagonal, or conical. While the capacity of the vessel depends on the size of pulverized media 20, a capacity of 0.5 liters or more may be practically usable.

Stirring vanes 16 formed by a plurality of coaxially mounted pins are mounted on the rotating shaft 15. While the pin may be circular in section, it may also take other sectional forms such as a rectangular, hexagonal, or octagonal. The stirring vane 16 may be formed of a pair of pins mounted in symmetrical form, or four to eight pins may be mounted coaxially in symmetrical form. The stirring vane 16 may also be a flat disc or conical disc having holes such as to allow the pulverized media 20 to pass therethrough. The distance between the top of the stirring vane 16 and the inner surface of the vessel 10 is preferably at least three times the diameter of the pulverized media. The inside of the rotating shaft 15 is a cooling water path 15a so that cooling water can circulate therethrough. The rotating shaft is rotated by a rotational power source (not shown) at a peripheral speed of 8 to 12 m/sec. The outside of the vessel 10 is a cooling water flow path 17.

The pulverized media 20 are made of spherical, flat, or amorphous steel, ceramic, stone, or the like. For example, a spherical medium may have an average grain size of 0.3 to 3 mm. The rate of loading of the pulverized media 20 is from 70 to 95%, or preferably from 85 to 90%.

A partition 13 includes a rotating disc 13a mounted on the rotating shaft 15, and a ring-like plate 13b fixed to the inner wall of the vessel 10. A

slit-like gap 14 is formed between the disc 13a and the plate 13b. The width of the slit does not allow a dispersed material to pass therethrough, but allows the pulverized media 20 to pass therethrough. If the average size of a spherical pulverized medium 20 is 1.5 mm, the width of the slit is set to about 0.3 to 0.4 mm.

The vessel 10 is divided into a first chamber 10a and a second chamber 10b by the partition 13. While two chambers are formed by the partition 13 as shown in Fig. 1, the number of chambers may be larger than two. It is preferable to arrange two to six stirring vanes along the length of the rotating shaft 15 in each chamber.

The gap 14 may be slit-like, or may be in the form of a plurality of small holes. The gap 14 is preferably formed close to the inner wall of the vessel 10. The reason for this is as follows. When the rotating vanes 16 rotate, the pulverized media 20 are distributed in the vicinity of the inner wall of the vessel 10 by centrifugal force. Therefore, while the material to be dispersed which is near the vessel 10 is distributed by the pulverized media 20 efficiently, the material to be dispersed which is near the rotating shaft 15 is dispersed poorly. Thus, the material that has been dispersed satisfactorily must be transferred to the next chamber efficiently.

The partition 13 includes the disc 13a releasably fixed to the rotating shaft 15 and the ring-like plate 13b fixed to the inner wall of the vessel. The radius of the disc 13a is larger than the radius of gyration of the stirring vane 16 so that a dispersing apparatus can be obtained which is easy to disassemble and maintain.

A material supply inlet 11 for supplying the material to be dispersed is formed at one end of the vessel 10, when the material comprises a powder pigment and a varnish or a solvent or the like, so that the material can be supplied continuously from the material supply inlet 11. The material dispersed in the chambers 10a and 10b of the vessel 10 is designed to be discharged continuously from a discharge outlet 12 through a slit 19 of a partition 18 that is of the same design as the partition 13.

Pulverized media of varying grain sizes may be loaded into the respective chambers in the dispersing apparatus of the invention. That is, pulverized media having a relatively large grain size may be loaded in the first chamber, and pulverized media having a smaller grain size loaded in the next chamber. Such an arrangement contributes to efficient dispersing.

Since the conventional dispersing apparatus is designed so that its vessel is formed of a single chamber, the pulverized media are subjected to density distribution by the centrifugal force of the

rotating vanes so as to cause the material dispersed by the pulverized media of small density to be discharged from the discharge outlet as insufficiently dispersed. However, in the dispersing apparatus of the invention, as the vessel is divided into two or more chambers. Therefore, the material to be dispersed undergoes a pulverizing and dispersing process in the first chamber, and only the dispersed material is allowed to pass through the partition thereafter so that the transfer distance of the dispersed material is long, is pulverized and dispersed sufficiently.

Further, since the conventional continuous dispersing apparatus supplies the material to be dispersed continuously, a stream of the dispersed material is produced within the vessel, thereby tending to distribute the pulverized media locally on the discharge outlet side by the transfer force. According to the invention, which is characterized by dividing the vessel by the partition, such a disadvantage is reduced. As a result, the conventional upper limit of the rate of loading of the pulverized media, which is about 85%, can be improved to about 90% or more by the dispersing apparatus of the invention.

As a result of the above-described advantages, the invention can improve the productivity of producing a printing ink mill basis by about 50% over the productivity of the conventional dispersing apparatus of the same capacity.

Claims

1. A continuous dispersing apparatus comprising:
 - a vessel containing pulverized media;
 - a supply inlet and a discharge outlet formed at respective ends of said vessel;
 - a rotating shaft passing through the vessel;
 - a partition dividing said vessel into a plurality of chambers, said partition defining a gap preventing passage of said pulverized media between said chambers while passing a dispersed material; and
 - at least one stirring means mounted on said rotating shaft in each of said chambers.
2. The continuous dispersing apparatus according to claim 1, wherein said partition comprises a rotating disc mounted on said rotating shaft and a ring-like plate fixed on an inner wall of said vessel, said gap being formed between said rotating disc and said ring-like plate.
3. The continuous dispersing apparatus according to claim 2, wherein said gap is a slit-like gap.
4. The continuous dispersing apparatus according to claim 1, wherein said gap is formed close to

an inner wall of said vessel.

5. The continuous dispersing apparatus according to claim 1, wherein said partition is formed between said discharge outlet and a one of said plurality of chambers adjacent to said discharge outlet. 5
6. The continuous dispersing apparatus according to claim 2, wherein said disc is releasably fixed on said rotating shaft, and the radius of said disc is larger than the length of said stirring means. 10
7. The continuous dispersing apparatus according to claim 1, wherein the distance between the top of said stirring means and an inner surface of said vessel is at least three times the diameter of said pulverized media. 15
8. The continuous dispersing apparatus according to claim 1, wherein two to six stirring means are arranged in each of said chambers. 20

20

25

30

35

40

45

50

55

FIG. 1

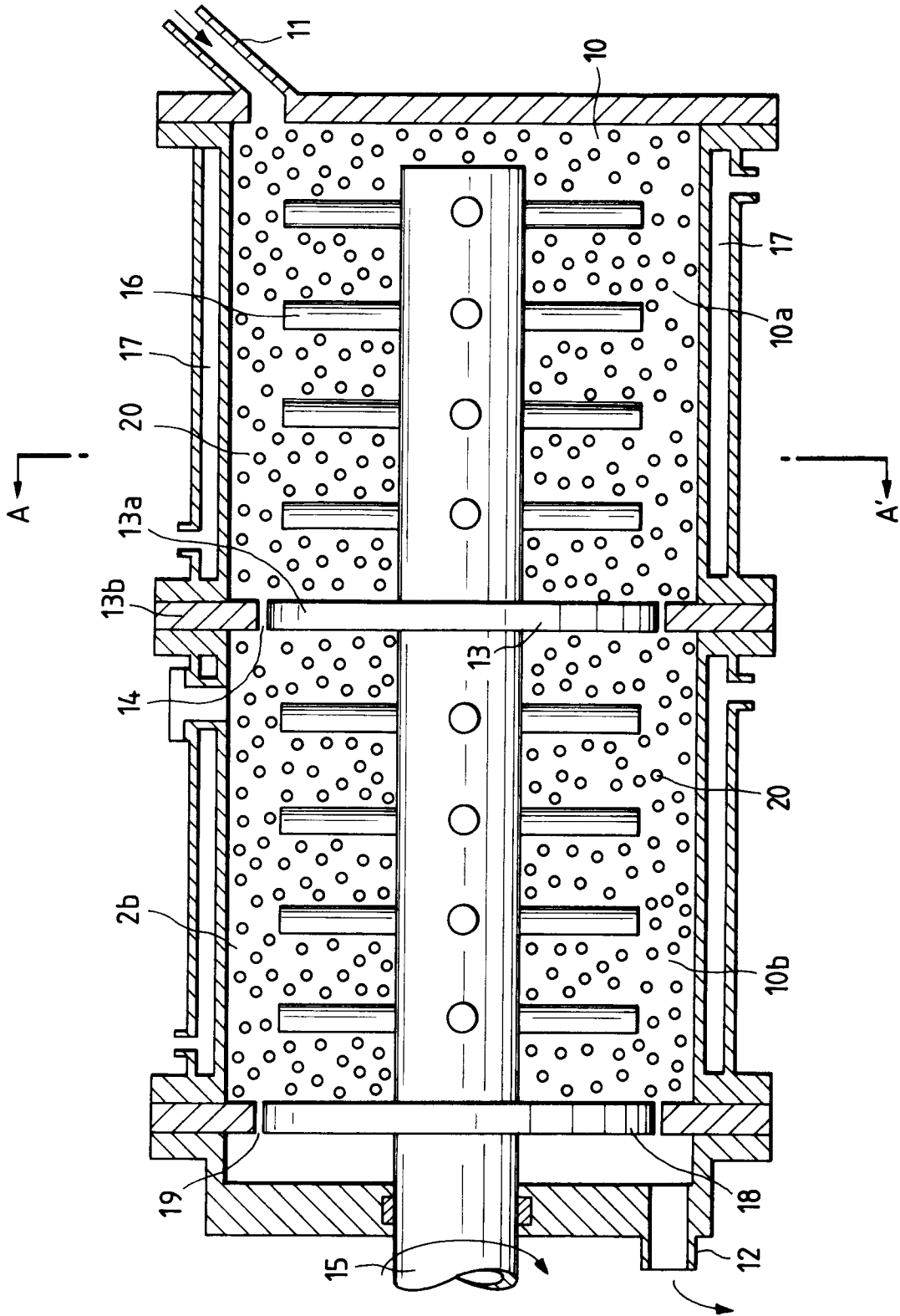

FIG. 2

