

(19) World Intellectual Property Organization  
International Bureau



(43) International Publication Date  
30 September 2010 (30.09.2010)

(10) International Publication Number  
**WO 2010/108444 A1**

- (51) International Patent Classification:  
*B01F 7/16* (2006.01)      *B01F 3/08* (2006.01)  
*B01F 13/08* (2006.01)
- (21) International Application Number:  
PCT/CN2010/071311
- (22) International Filing Date:  
25 March 2010 (25.03.2010)
- (25) Filing Language: English
- (26) Publication Language: English
- (30) Priority Data:  
200920053461.X 27 March 2009 (27.03.2009) CN
- (72) Inventor; and  
(71) Applicant : CHIU, Shun Pui, Andrew [CN/CN]; Yijia Electronic Factory, 128 Industrial Zone, Tangxia Town, Dongguan, Guangdong 523000 (CN).
- (74) Agent: GUANGZHOU NANFENG PATENT AGENCY CO., LTD; 2/F, Experiment Bldy, No.100, XianlieRoad, M, Guangzhou, Guangdong 510070 (CN).

- (81) Designated States (unless otherwise indicated, for every kind of national protection available): AE, AG, AL, AM, AO, AT, AU, AZ, BA, BB, BG, BH, BR, BW, BY, BZ, CA, CH, CL, CN, CO, CR, CU, CZ, DE, DK, DM, DO, DZ, EC, EE, EG, ES, FI, GB, GD, GE, GH, GM, GT, HN, HR, HU, ID, IL, IN, IS, JP, KE, KG, KM, KN, KP, KR, KZ, LA, LC, LK, LR, LS, LT, LU, LY, MA, MD, ME, MG, MK, MN, MW, MX, MY, MZ, NA, NG, NI, NO, NZ, OM, PE, PG, PH, PL, PT, RO, RS, RU, SC, SD, SE, SG, SK, SL, SM, ST, SV, SY, TH, TJ, TM, TN, TR, TT, TZ, UA, UG, US, UZ, VC, VN, ZA, ZM, ZW.
- (84) Designated States (unless otherwise indicated, for every kind of regional protection available): ARIPO (BW, GH, GM, KE, LR, LS, MW, MZ, NA, SD, SL, SZ, TZ, UG, ZM, ZW), Eurasian (AM, AZ, BY, KG, KZ, MD, RU, TJ, TM), European (AT, BE, BG, CH, CY, CZ, DE, DK, EE, ES, FI, FR, GB, GR, HR, HU, IE, IS, IT, LT, LU, LV, MC, MK, MT, NL, NO, PL, PT, RO, SE, SI, SK, SM, TR), OAPI (BF, BJ, CF, CG, CI, CM, GA, GN, GQ, GW, ML, MR, NE, SN, TD, TG).

[Continued on next page]

(54) Title: SMALL-SIZE TEST PAINT POT ASSEMBLY

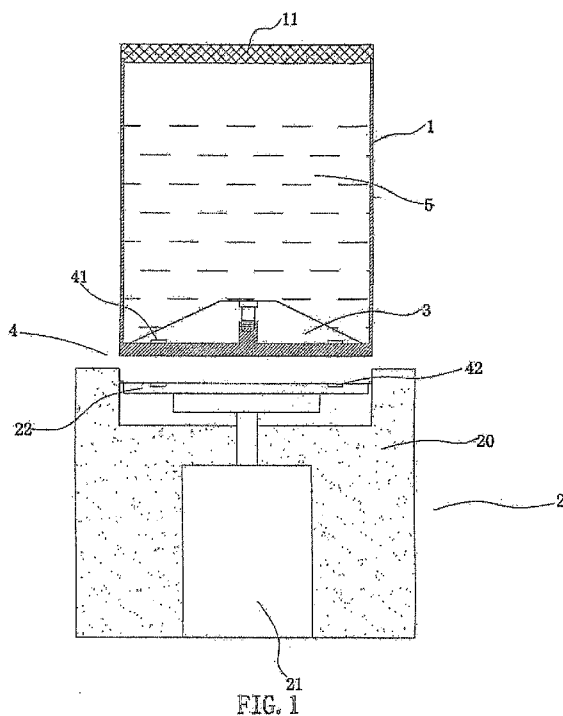

(57) Abstract: A small-size test paint pot assembly for color-matching and mixing of paints comprises a pot body (1), a driver (2) independent from the pot body (1), and a stirrer (3) mounted in the pot body (1) and driven by the driver (2). The stirrer (3) is configured as a stirring impeller which is rotatably provided at the bottom of a chamber defined by the pot body (1). The stirrer (3) is coupled to the driver (2) by a coupling mechanism (4). The coupling mechanism (4) may adopt a magnetic coupling (41, 42) or may simply adopt a shaft connection (43, 44). The small-size test paint pot assembly is advantageous in that: first, the small volume of the pot body (1) allows the user to buy small amount of prepared paint for testing with no waste; second, it makes sure that no deviation occurs in the prepared paint.

WO 2010/108444 A1

Published:

— with international search report (Art. 21(3))

## Small-size test paint pot assembly

### Technical Field

The present invention relates to the technical field of paint pot products, and specifically relates to a small-size test paint pot assembly for colour-matching and mixing of paints.

### Background Art

Paints will be used during decoration of a house or fabrication of a furniture or other products. Paints having different colours may be selected according to different requirements or personal preferences. Colours of paints sold by an ordinary manufacturer are limited and can not meet requirements of users. Thus, according to his/her individual need, a user may mix paints of different colours with a certain ratio to form paint of a new colour. The paints used for colour-matching are herein referred to as tinters. Conventionally, paints are mixed manually by an operator, who may obtain a desired colour according to his/her experience or different experiments. However, such a process of paint mixing is disadvantageous in that the procedure of colour-matching is complicated, and the colour of the paint mixed for a second time may be different from that for the first time.

To solve the above problems, some manufacturers have developed apparatus used for automatic colour-matching of paints. Many colours calculated by a computer, as well as the amount of tinters needed for obtaining a paint having a respective colour, are stored in the apparatus. The user only needs to select a preferred colour and input it into the computer. Afterwards, the apparatus will automatically mix different tinters together to obtain a paint having the preferred colour. Such an apparatus has greatly solved the prolonged problem, and facilitated users to a great extent. Generally, a white paint is used as a base material in the apparatus, and the tinter or tinters are used as additives. By adding different amounts of tinter into the white base material, the latter will show a desired colour.

Though the above apparatus has solved, to a certain degree, many problems encountered by users, they are still defective in certain aspects. Many users do not know whether the mixed paint can meet the actual style of decoration, and a mismatch between the colour of the purchased paint and the actual style of decoration occurs frequently. Unfortunately, at present, none of the paint sellers can provide mixed paints in test paint pots and users can only buy a full pot of mixed paint. Accordingly, if the colour of the mixed paint is not matched with the style of decoration, either a paint with a new colour should be mixed again and purchased, or the paint with a deviation in colour should be used. Further, even if users can buy paints with small amount, it is still very difficult to have them mixed thoroughly to achieve a prescribed colour, since there is no colour-matching and mixing apparatus or device in the market designated for paint of such a small amount.

Consequently, the applicant has designed a small-size test paint pot assembly, so as to solve the above problem.

15

### Summary

The problem to be solved by the present invention is to overcome the defects in prior art products and to provide a small-size test paint pot assembly, which can provide a small amount of paint for testing, and is provided with a device for uniformly mixing the paints.

20

Another technical problem to be solved by the present invention is to provide a paint pot assembly capable of automatically adjusting the colour difference of a paint.

To solve the above technical problems, the present invention adopts the following technical solutions: the small-size test paint pot assembly comprises a pot body and a driver independent from the pot body, with a stirrer driven by the driver being mounted in the pot body.

25

Preferably the stirrer is configured as a stirring impeller which is rotatably provided at the bottom of a chamber defined by the pot body. The stirrer is coupled to the driver by a coupling mechanism.

Preferably the coupling mechanism is so configured that magnets are provided on a lower surface of the blades of the stirrer, and magnets or iron members magnetized by the magnets on the stirrer are correspondingly provided on a turntable that is rotatably driven by a motor of the driver.

5 Preferably the coupling mechanism is so configured that a connecting shaft between the stirrer and the pot body extends beyond the pot body, and is rotatably driven by the motor of the driver.

Preferably the connecting shaft is provided at its end outside the pot body with a snapping member. A snapping groove corresponding to the snapping member is  
10 formed on a rotating member that is driven by the motor of the driver.

Provided in a sidewall of the pot body is a transparent window, through which the colour of the paint in the pot body can be seen directly. Therefore, a colour sensing unit may be used to determine whether a colour difference exists between the colour of the paint in the pot body and the colour of the paint actually needed. If there exists a  
15 colour difference, the colour sensing unit will feed back the collected data and the paint will be prepared once more.

The volume of the pot body is in the range of 40 to 100 ml.

The present invention mainly comprises a paint pot with very small volume, and the paint contained in the pot body can be mixed and prepared by a stirrer provided in  
20 the pot body. The present invention is advantageous in that the volume of the pot body of the present invention is small, so that a user only needs to buy small amount of prepared paint for testing. If the testing result is consistent with the actual requirement, i.e. the colour of the prepared paint matches with the actual style of decoration, the user can buy and prepare a large amount of paint according to the  
25 preparation ratio. Thus, the user can test the paint before painting, meanwhile, the amount for testing is small and there produces no waste. Further, the present invention per se has functions of paint mixing and colour-matching, which facilitates the user and makes sure no deviation occurs in the prepared paint. Lastly, the present invention has the function of automatically colour-matching.

### Brief Description of the Drawings

The present invention will be further described with reference to the accompanying drawings, in which:

5 Fig. 1 is a schematic view of a first embodiment of the present invention;

Fig. 2 is a bottom view of a stirrer according to the first embodiment of the present invention;

Fig. 3 illustrates an exploded perspective view of a pot body according to the first embodiment of the present invention;

10 Fig. 4 is a schematic view of a second embodiment of the present invention;

Fig. 5 illustrates a state of use of a small-size test paint pot assembly according to the present invention;

Fig. 6 is a perspective view of a third embodiment of the present invention; and

15 Fig. 7 illustrates a state of use of a small-size test paint pot assembly according to the third embodiment of the present invention.

### Detailed Description

Figures 1, 2 and 3 show a small-size test paint pot assembly according to a first embodiment of the present invention. The test paint pot assembly comprises a pot  
20 body 1 and a driver 2. The pot body 1 is a small-size pot with a volume of 50 ml, which is variable in practical use and is generally in a range of 40 to 100 ml. The pot body 1 is provided with a cover 11 to form a sealed chamber for containing paint. The small-size test paint pot assembly further comprises a stirrer 3 mounted in pot body 1. The stirrer 3 is in the form of a stirring impeller with four blades, and is rotatably  
25 mounted on the bottom of the pot body 1. The stirrer 3 is coupled to the driver 2 through a coupling mechanism 4. The driver 2 is arranged opposite to the pot body 1 and comprises a base 20 and a motor 21 mounted in the base 20.

The configuration of the coupling mechanism 4 is as follows: magnets 41 are provided on a lower surface of the blades of the stirrer 3, and magnets or iron

members 42 magnetized by the magnets on the stirrer 3 are provided correspondingly on a turntable 22 that is rotatably driven by the motor 21 of the driver 2.

In use, the pot body 1 is firstly positioned on the base 20 of the driver 2. Formed in the upper surface of the base 20 is a recess capable of receiving the pot body 1. The  
5 turntable 22 driven by the motor 21 is positioned at the center of the recess.

When the motor 21 starts up, the turntable 22 rotates therewith. Owing to magnets 41, 42 correspondingly provided on the turntable 22 and the stirrer 3 respectively, a magnetic coupling is formed between the turntable 22 and the stirrer 3. Thus, when the turntable 22 starts to rotate, the stirrer 3 will be driven to rotate synchronously.

10 According to the above embodiment, the coupling mechanism is embodied as a magnetic coupling. However, other types of coupling may also be used. Figure 4 shows a small-size test paint pot assembly according to a second embodiment of the present invention, which is the same as the first embodiment except that another type of coupling mechanism 4 is used. The configuration of this coupling mechanism 4,  
15 which is of a different type, is as follows: a connecting shaft 31 between the stirrer 3 and the pot body 1 extends beyond the pot body 1, and is provided at an end outside the pot body 1 with a snapping member 43. The motor 21 of the driver 2 drives a rotating member 23, on which a snapping groove 44 corresponding to the snapping member 43 is formed. In use, the pot body 1 is firstly positioned on the base 20 of the  
20 driver 2. Formed in the upper surface of the base 20 is a recess capable of receiving the pot body 1. The rotating member 23 driven by the motor 21 is positioned at the center of the recess. When the motor 21 starts up, the rotating member 23 rotates therewith. Owing to the snapping member 43 and snapping groove 44 correspondingly provided on the stirrer 3 and the rotating member 23 respectively, the  
25 rotating member 23, once starts to rotate, will drive the stirrer 3 to rotate synchronously through an engagement between the snapping member 42 and the snapping groove 44.

Figure 5 illustrates a state of use of a small-size test paint pot assembly according to the present invention. The test paint pot assembly according to the present

invention is equipped with a paint preparation apparatus, which mainly comprises a base and a number of containers 5 for receiving tinters. The containers 5 are distributed on the base along an annular path, and are brought into rotation by means of a motor through the base. Each container is filled with a unique tinter. Based on colour information input into a computer, some containers 5 will be controlled to respectively rotate into an output position, where an amount of tinter will be discharged from the container 5 into the pot body 1 via a discharge device 6 according to the ratio calculated by the computer. After that, the driver 2 starts up and drives the stirrer 3 so as to mix the paints in the pot body 1 thoroughly to obtain a paint with desired colour. Finally, the pot body 1 is sealed with the cover 11 so as to be used for testing. Usually, the pot body 1 will have a base paint (typically white) present before the tinters are added. Alternatively, the base paint could be included in one of the containers 5 and added to the pot body.

Figures 6 and 7 show another embodiment of the present invention. According to this embodiment, a transparent window 10 is provided in a sidewall of the pot body 1, so that a state of the paint in the pot body 1, such as the colour and volume of the paint, can be seen via this window. Further, due to the presence of the transparent window 10, a colour difference of the colour of the paint in the pot body 1 can be adjusted automatically. As can be seen from figure 7, a colour-sensing unit 7, e.g. a scanner (or camera) capable of recognizing colours, is provided right opposite to the transparent window 10 of the pot body 1. The colour-sensing unit 7 is connected to a control circuit 8 which is also used for controlling the whole paint preparation apparatus. In use, certain amounts of paints are discharged from different containers 5 via the discharge device 6 into the pot body 1 based on a colour information C1 input into the computer. After that, the driver 2 starts up and drives the stirrer 3 so as to thoroughly mix the paints in the pot body 1 to obtain a paint with a desired colour. Then, the colour sensing unit 7 will scan the paint presently in the pot body 1 via the transparent window 10, obtain a colour value C2, and feed back this colour value C2 to the control circuit 8. The colour value C2 will be compared with the colour

information C1 in the control circuit 8. If a colour difference exceeds an allowable error range, the control circuit 8 will calculate a deviation value C3 (C1-C2) and then re-drive the paint preparation apparatus to add other tinters, so as to limit the difference between the colour value C2 of the paint in the pot body 1 and the desired colour value C1 within the allowable range.

The principle of adjusting the colour value of the paint according to this embodiment is as follows: if the colour value of the paint is decomposed into three basic colours RGB, the input colour value C1 can be expressed as C1 (C<sub>R1</sub>, C<sub>G1</sub>, C<sub>B1</sub>), the actual measured colour value C2 can be expressed as C2 (C<sub>R2</sub>, C<sub>G2</sub>, C<sub>B2</sub>), and the deviation value C3 can be expressed as C3 (ΔC<sub>R</sub>, ΔC<sub>G</sub>, ΔC<sub>B</sub>) = C3 (C<sub>R2</sub>-C<sub>R1</sub>, C<sub>G2</sub>-C<sub>G1</sub>, C<sub>B2</sub>-C<sub>B1</sub>). If any one of the ΔC<sub>R</sub>, ΔC<sub>G</sub>, ΔC<sub>B</sub> in C3 is greater than zero, a white paint or a colourless solvent needs to be added into the current paint to dilute the same, so as to decrease the value of C2 until any one of the ΔC<sub>R</sub>, ΔC<sub>G</sub>, ΔC<sub>B</sub> in C3 is less than or equal to zero, for example until the ΔC<sub>R</sub> and ΔC<sub>G</sub> in C3 are both less than zero and the ΔC<sub>B</sub> is equal to zero. Then, a paint with a corresponding colour needs to be added into the current paint to make the ΔC<sub>R</sub> and ΔC<sub>G</sub> equal to zero.

The above embodiments are only intended to illustrate the present invention by way of preferred embodiments without restricting the scope of the present invention thereto. Accordingly, all the changes and modifications made to the shape, construction, feature and spirit defined in the claims of the present invention fall into scope of the present invention.

## Claims

1. A small-size test paint pot assembly, comprising a pot body (1), characterized in that the small-size test paint pot assembly further comprises

5 a driver (2) independent from the pot body (1), and

a stirrer (3) which is mounted in the pot body (1) and is driven by the driver (2).

2. The small-size test paint pot assembly as set forth in claim 1, characterized in that

10 the stirrer (3) is configured as a stirring impeller which is rotatably provided at the bottom of a chamber defined by the pot body (1), and

the stirrer (3) is coupled to the driver (2) by a coupling mechanism (4).

3. The small-size test paint pot assembly as set forth in claim 2, characterized in that

15 the coupling mechanism (4) is so configured that magnets (41) are provided on a lower surface of the blades of the stirrer (3), and magnets or iron members (42) magnetized by the magnets (41) on the stirrer (3) are correspondingly provided on a turntable (22) that is rotatably driven by a motor (21) of the driver (2).

4. The small-size test paint pot assembly as set forth in claim 2, characterized in that

20 the coupling mechanism (4) is so configured that a connecting shaft (31) between the stirrer (3) and the pot body (1) extends beyond the pot body (1), and is rotatably driven by the motor (21) of the driver (2).

5. The small-size test paint pot assembly as set forth in claim 4, characterized in that

25 the connecting shaft (31) is provided at its end outside the pot body (1) with a snapping member (43), and

a snapping groove (44) corresponding to the snapping member (43) is formed on a rotating member (23) that is driven by the motor (21) of the driver (2).

6. The small-size test paint pot assembly as set forth in any one of claims 1 to 5,

characterized in that

a transparent window (10) is provided in a sidewall of the pot body (1).

7. The small-size test paint pot assembly as set forth in claim 6, characterized in that

5 a volume of the pot body (1) is in the range of 40 to 100 ml.

10

15

20

25

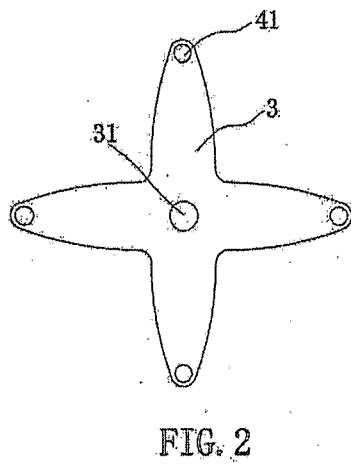
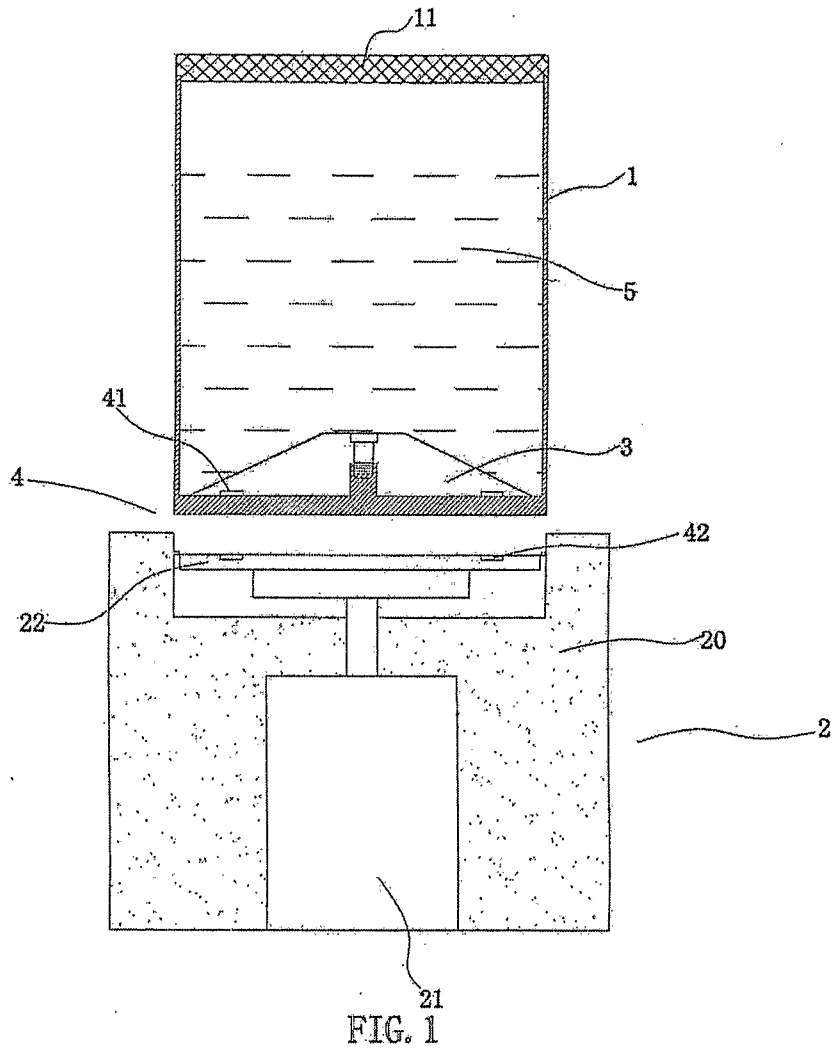

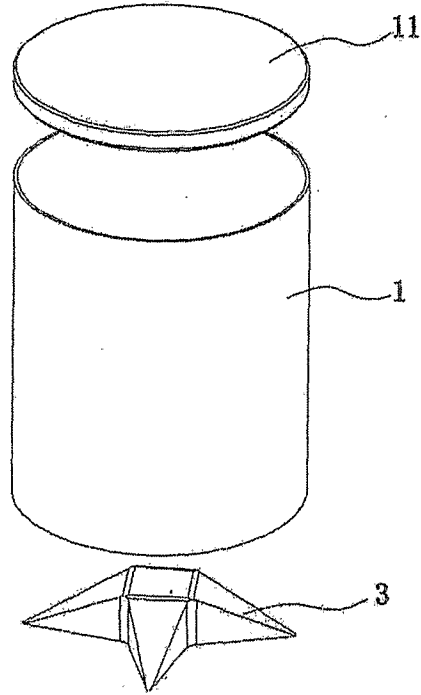

FIG. 3

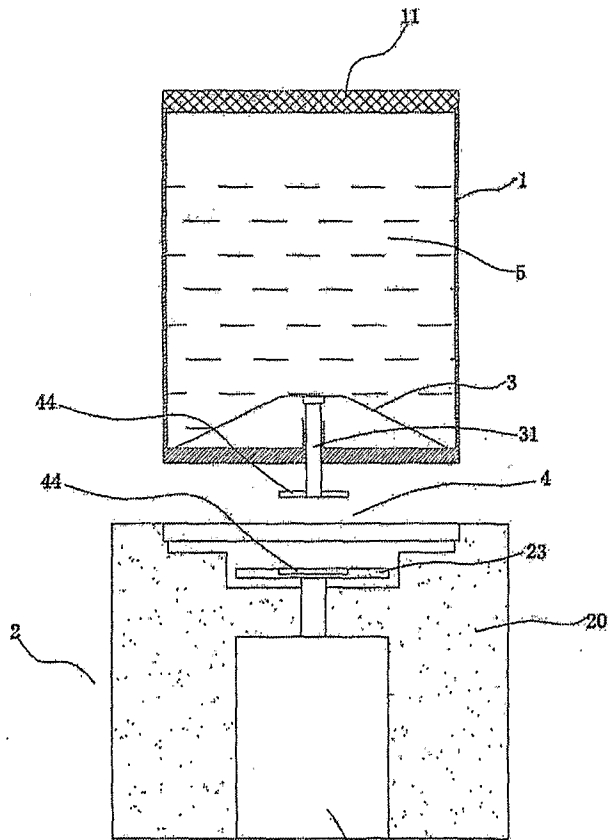

FIG. 4

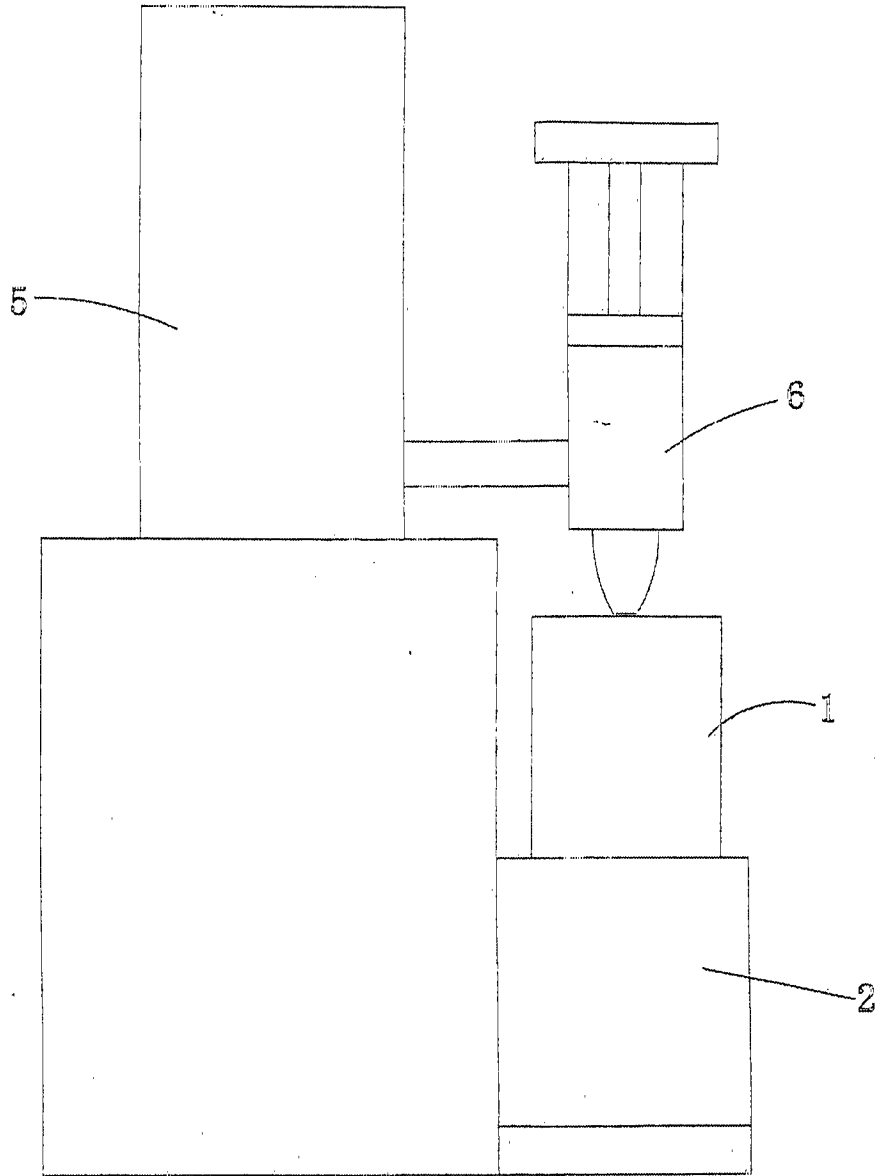

FIG. 5

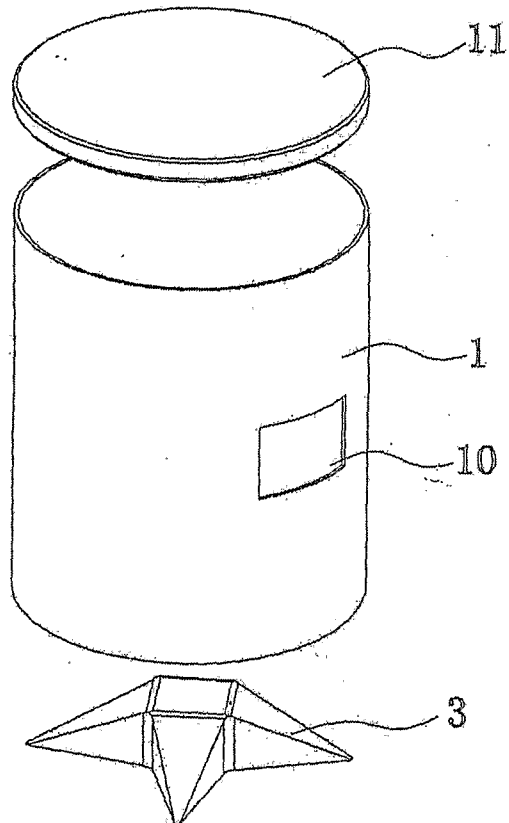
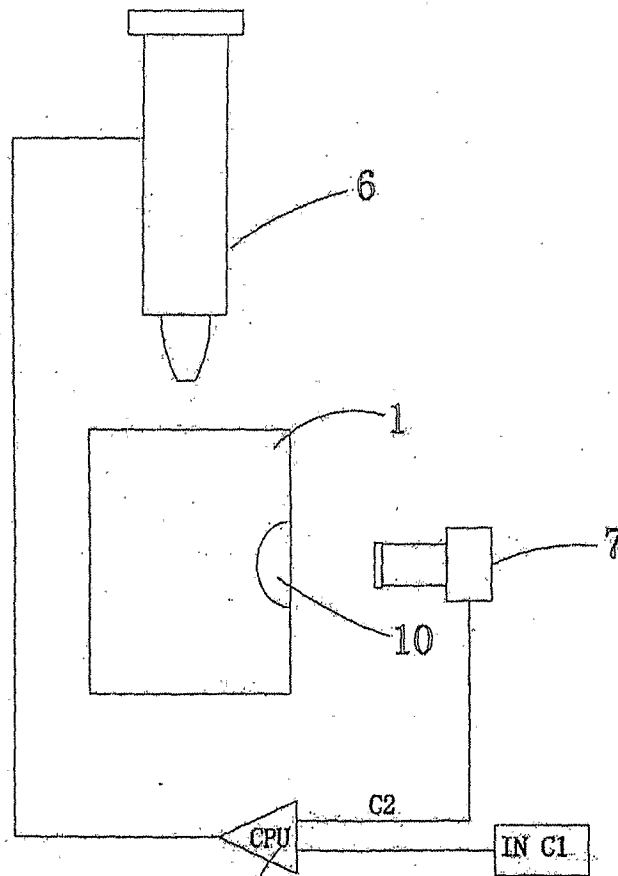

FIG. 6



8 FIG. 7

# INTERNATIONAL SEARCH REPORT

International application No.

PCT/CN2010/071311

## A. CLASSIFICATION OF SUBJECT MATTER

see the extra sheet

According to International Patent Classification (IPC) or to both national classification and IPC

## B. FIELDS SEARCHED

Minimum documentation searched (classification system followed by classification symbols)

IPC: B01F

Documentation searched other than minimum documentation to the extent that such documents are included in the fields searched

Electronic data base consulted during the international search (name of data base and, where practicable, search terms used)

WPI, EPODOC, CNPAT, CNKI (mix+, stir+, agitat+, paint, coat+)

## C. DOCUMENTS CONSIDERED TO BE RELEVANT

Category*	Citation of document, with indication, where appropriate, of the relevant passages	Relevant to claim No.
X	JP61216680A(SHIBAURA SEISAKUSHO KK) 26 Sep. 1986(26.09.1986) figure 2	1-3,6-7
X	CN1225291A(DE SINANO C) 11 Aug. 1999(11.08.1999) page 3, line 2-page 4, line 18, figures 1-4	1-3,6-7

 Further documents are listed in the continuation of Box C. See patent family annex.

* Special categories of cited documents:	“T” later document published after the international filing date or priority date and not in conflict with the application but cited to understand the principle or theory underlying the invention
“A” document defining the general state of the art which is not considered to be of particular relevance	“X” document of particular relevance; the claimed invention cannot be considered novel or cannot be considered to involve an inventive step when the document is taken alone
“E” earlier application or patent but published on or after the international filing date	“Y” document of particular relevance; the claimed invention cannot be considered to involve an inventive step when the document is combined with one or more other such documents, such combination being obvious to a person skilled in the art
“L” document which may throw doubts on priority claim (S) or which is cited to establish the publication date of another citation or other special reason (as specified)	“&” document member of the same patent family
“O” document referring to an oral disclosure, use, exhibition or other means	
“P” document published prior to the international filing date but later than the priority date claimed	

Date of the actual completion of the international search  
19 May 2010(19.05.2010)Date of mailing of the international search report  
**01 Jul. 2010 (01.07.2010)**Name and mailing address of the ISA/CN  
The State Intellectual Property Office, the P.R.China  
6 Xitucheng Rd., Jimen Bridge, Haidian District, Beijing, China  
100088  
Facsimile No. 86-10-62019451Authorized officer  
**LI, Jindong**  
Telephone No. (86-10)62084796

**INTERNATIONAL SEARCH REPORT**

International application No.

PCT/CN2010/071311

C (Continuation). DOCUMENTS CONSIDERED TO BE RELEVANT

Category*	Citation of document, with indication, where appropriate, of the relevant passages	Relevant to claim No.
X	CN2131598Y(XU, Zhengkun et al.) 5 May 1993(05.05.1993) page 3, lines 10-20, figure 1	1-3,6-7
X	US20050206260A1(AKIYAMA S) 22 Sep. 2005(22.09.2005) paragraphs 129-146, figures 7-8	1-3,6-7
X	CN2539761Y(MATSUSHITA ELECTRIC IND CO LTD) 12 Mar. 2003(12.03.2003) example 1, figure 1	1-2,4-7

**INTERNATIONAL SEARCH REPORT**  
**Information on patent family members**

International application No.  
PCT/CN2010/071311

Patent Documents referred in the Report	Publication Date	Patent Family	Publication Date
JP61216680A	26.09.1986	None	
CN1225291A	11.08.1999	EP0822000A1	04.02.1998
		IT1283680B	23.04.1998
CN2131598Y	05.05.1993	None	
US20050206260A1	22.09.2005	EP1578009A2	21.09.2005
		EP1578009A3	07.11.2007
		US7112904B	26.09.2006
		JP2005269709A	29.09.2005
		JP2007074900A	22.03.2007
CN2539761Y	12.03.2003	None	

# INTERNATIONAL SEARCH REPORT

International application No.

PCT/CN2010/071311

Continuation of A. **CLASSIFICATION OF SUBJECT MATTER**

B01F7/16(2006.01)i

B01F13/08(2006.01)i

B01F3/08(2006.01)i