

*B. Frantz,
Wind Wheel.*

N.º 13,247.

Patented July 10, 1855.

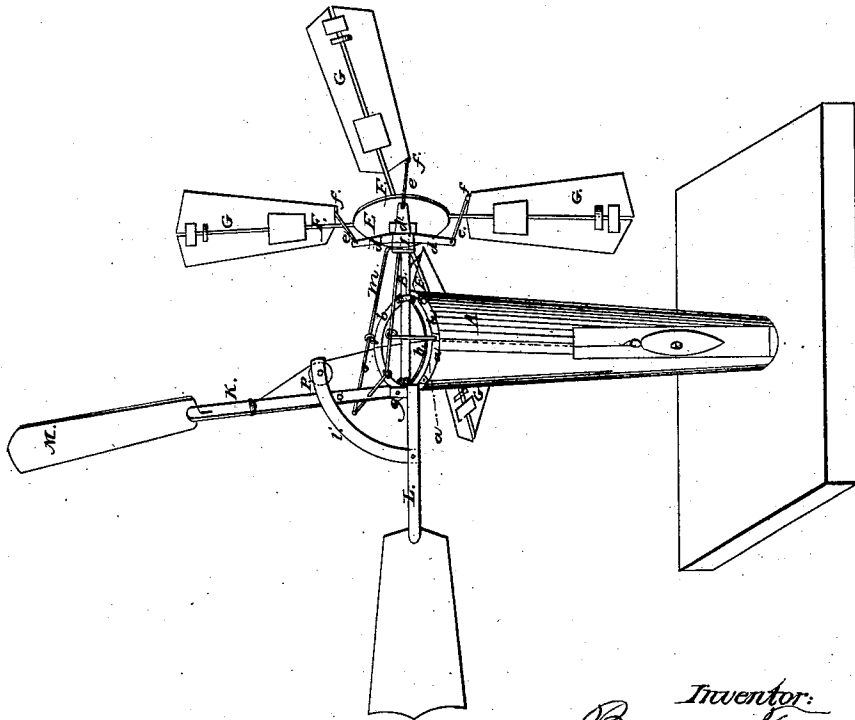
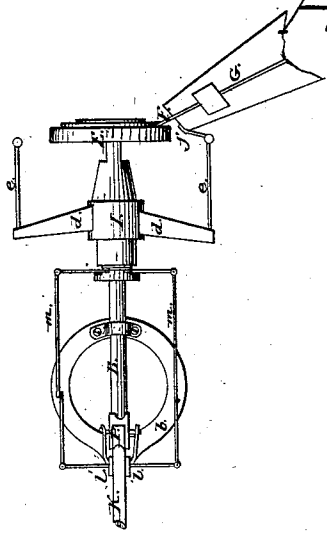

*Inventor:
B. Frantz*

UNITED STATES PATENT OFFICE.

BENJAMIN FRANTZ, OF WAYNESBOROUGH, PENNSYLVANIA, ASSIGNOR TO
JOHN PHILLIPS.

SELF-REGULATING WINDMILL.

Specification forming part of Letters Patent No. 13,247, dated July 10, 1855.

To all whom it may concern:

Be it known that I, BENJAMIN FRANTZ, of Waynesborough, county of Franklin, and State of Pennsylvania, have invented certain new and useful Improvements in Self-Adjusting Regulators of Windmills; and I do hereby declare that the following is a full, clear, and exact description thereof, reference being had to the accompanying drawings, and to the letters of reference thereon, forming a part of this specification.

The nature of my improvement is the immediate change of position of the wings or sails by the direct agency of the wind itself as a means of such change; and it consists in the addition of a lever with a sail or fan thereon denominated a "wind-lever," placed in such a manner that the wind, when too violent or coming in puffs or gusts, shall depress the lever and with it draw the sliding head and operate through rods, &c., upon the pivoted wings of the mill, and bring their edges by a self-adjustment to the eye of the wind or obliquely thereto in proportion to the violence of the gust. This improvement is important, as it renders the action of all kinds of winds (no matter how violent, sudden, or irregular) gentle and controllable by the force of the storm itself upon the wind-lever, and thus prevents those accidents incident to ordinary windmills. By the addition of extra weight to the counterpoise of the lever the position of the wings or sails may be maintained, as the heavier the weight the less sensitive the wings.

To enable others to fully understand the construction of and use of my improvement, I will describe it as follows:

A represents a post having upon the top thereof a circular ring *a*, upon which the main shaft changes position in bringing the wings to the wind.

B is a horizontal shaft furnished with suitable bearings on a cap-plate *b*, lying upon the ring *a*. Upon the outer or projecting end of B is secured a head E, from which project four arms F F, on which the wings or sails G G swivel or turn.

I is a sliding collar on shaft B, having radial arms *d d* projecting therefrom.

e e are strap-rods having one end attached

to *d* and the other to projecting pins on a short offset *f* upon the lower edge of the wings. Upon sliding the collar I the position of the wings is changed in their obliquity to the direction of the wind and the edge more or less presented.

K is a pivoted wind-lever having its fulcrum at *g* on the turn cap-plate *b*. From the cap-plate projects in a direction opposite to that of B a bar L, carrying upon its extremity a vane by which the cap *b* is turned and the wings brought to face the wind. From the upper side of L rise guides *l' l'*, embracing the wind-lever between them.

M is a fixed sail on the end of *k*, and *m m* a pair of rods connecting the sliding collar I with the wind-lever K, when the wind suddenly strikes the sail M and depresses it, drawing the rods and sliding collar on the shaft B, which in turn draws the rods *e e* and thus brings the edge of the wings, if the force of the wind is extreme, to the eye of the wind and necessarily arrests the rapidity of the mill by presenting less surface to its violence.

O is a counter-weight and cord attached to the upper end of the wind-lever, the cord passing over a pulley P, the use of which is to bring K into a vertical position, and thus restore the sliding collar and wings to the position they occupied before the wind-lever was depressed. As before remarked, when it is desirable to lessen the sensitiveness of the wind-lever, it is only necessary to increase the weight of the counterpoise without diminishing in the least from the efficiency of the invention to prevent accident from sudden gusts or changes of the wind.

I am aware that there have been numbers of contrivances by counter-weights attached to the wings, springs, &c., governors by water apparatus, &c.; but in no instance has the direct agency of the storm itself been made subservient to the end so desirable—viz., so controlling the motion of the wings or sails that they shall at all times be safe and yet efficient, so that the axiom may be "the stronger she blows the slower she goes," as applied to windmills.

Having described my improvement, what I claim as my invention, and desire to secure by Letters Patent of the United States, is—

Making a direct use of the wind itself for governing windmills by means of the wind-lever K or its equivalent, connecting-rods *m m*, collar I, and strap-rods *e e*, in combination with the wings G G, substantially in the manner set forth in the foregoing specification.

In testimony whereof I have hereunto signed my name, before two subscribing witnesses, June 11, 1885.

BENJ. FRANTZ.

Witnesses:

JOHN NILL,
GEORGE JACOBS.