

No. 879,502.

J. VAN OOSTERWYCK.  
STEAM GENERATOR.  
APPLICATION FILED MAY 28, 1906.

PATENTED FEB. 18, 1908.

2 SHEETS—SHEET 1.

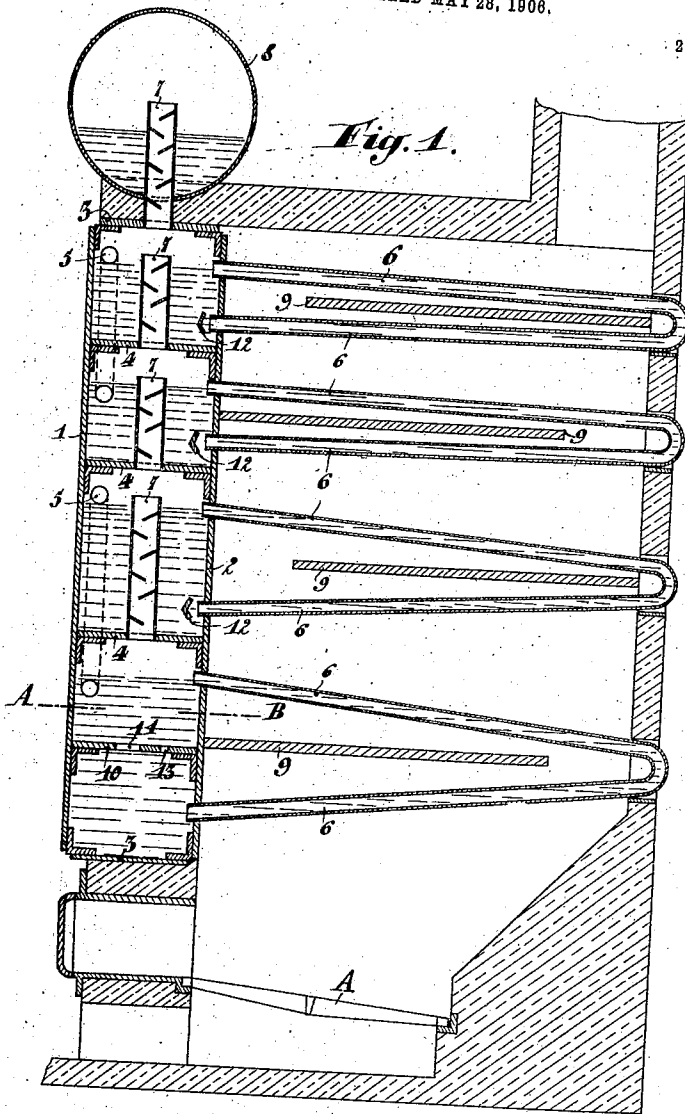

Fig. 1.

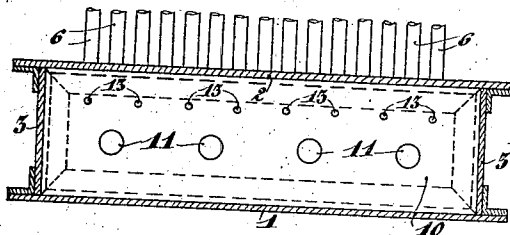

Fig. 2.

Witnesses:  
F. G. Harder.  
A. Frank.

Inventor:  
Jean Van Oosterwyck  
per Martin Schmetz  
Attorney.

No. 879,502.

PATENTED FEB. 18, 1908.

J. VAN OOSTERWYCK.  
STEAM GENERATOR.  
APPLICATION FILED MAY 28, 1906.

2 SHEETS—SHEET 2.

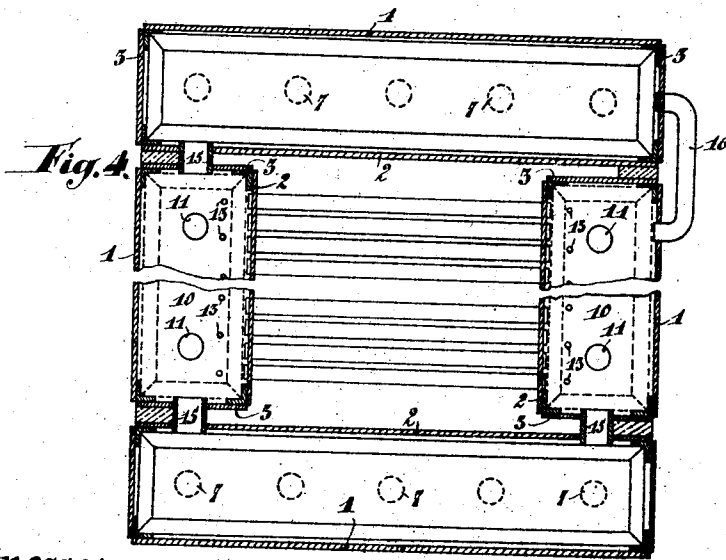
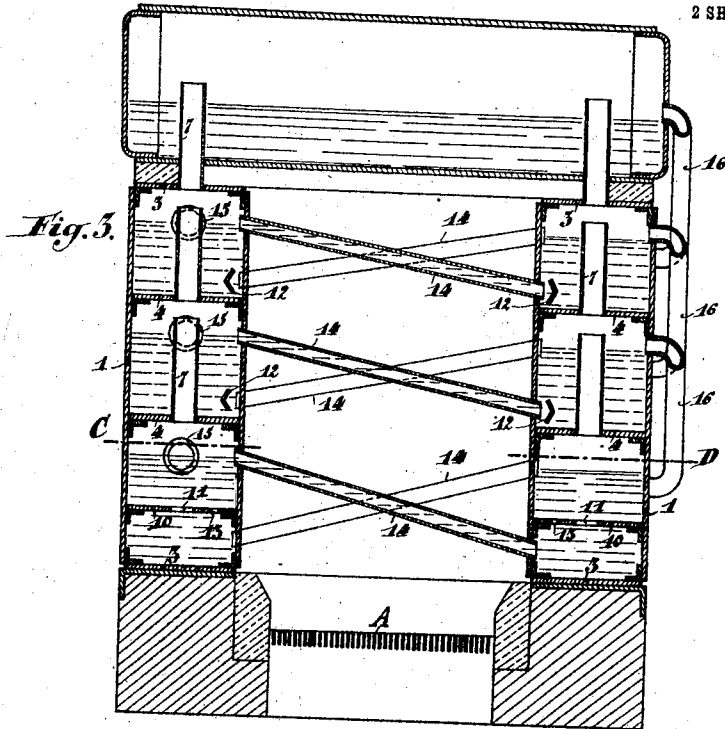

Witnesses:  
F. G. Hearder.  
A. Frank.

Inventor:  
Jean Van Oosterwyck  
per *Martin Schmetz*  
Attorney.

# UNITED STATES PATENT OFFICE.

JEAN VAN OOSTERWYCK, OF CHÈNÉE, BELGIUM.

## STEAM-GENERATOR.

No. 879,502.

Specification of Letters Patent.

Patented Feb. 18, 1908.

Application filed Mar. 28, 1906. Serial No. 318,999.

*To all whom it may concern:*

Be it known that I, JEAN VAN OOSTERWYCK, engineer, a subject of the King of Belgium, residing at Chênée, No. 81 Rue Large, in the Kingdom of Belgium, have invented certain new and useful Improvements in Steam-Generators; and I do hereby declare the following to be a full, clear, and exact description of the invention, such as will enable others skilled in the art to which it appertains to make and use the same.

My present invention relates to steam generators consisting of individual compartments of which each is provided with separated steam and water spaces, and in which compartments by means of a peculiar arrangement of groups of tubes an effective water circulation and therefore an intensive steam generation is obtained.

In the accompanying drawings:—Figure 1 is a vertical sectional view of the steam generator. Fig. 2 is a horizontal sectional view taken on the line A—B of Fig. 1. Fig. 3 is a vertical transverse sectional view of a modification of my invention. Fig. 4 is a sectional view taken on the line C—D of Fig. 3.

The superposed individual compartments of the steam generator are formed of the front-wall 1, rear-wall 2, side-walls 3 and the horizontal partition-walls 4 arranged one above the other. The feed-water passes in a well known manner by means of over-flow pipes 5 from an upper compartment to the next compartment below it.

To obtain a water circulation in the individual compartments groups of tubes 6 are employed, which are either made of one piece and bent V-shaped as shown in Fig. 1, or composed of two tubes joined in any suitable manner at the bend to obtain this V-shaped form. These tubes 6 are attached in rows in such a manner to the individual compartments, that their upper branches are put into communication with the steam spaces and their lower branches with the water spaces thereof. Under the influence of the fire-gases steam bubbles are generated, which follow the slanting branches of the tubes 6 and thereby compel the water contained in the individual compartments to participate in their motion. The steam generated in the individual compartments passes through the pipes 7 upwards to the steam-dome 8.

To guide the fire-gases deflecting partition-walls 9, consisting of fire-proof material are

arranged in zigzag form between the rows of tubes, as indicated in Fig. 1.

To prevent the steam generated in the lower tube-branches from reëntering the water spaces, which may occur when a violent generation of steam takes place in the lower branches of said tubes before the water circulation has set in, the lower compartment is provided with a division wall 10, whose holes 11 represent only a fraction of the cross-sectional area of the lower row of tube-branches next to the fire-grate A, so that these holes 11 offer a sufficient resistance to prevent the steam from reëntering the water space, and thus compel it to follow its prescribed route.

Instead of arranging a division-wall 10 in the upper compartments where the generation of steam is naturally less rapid than in the bottom compartment, it suffices to arrange baffle-plates 12 of suitable cross-section in front of the lower tube branches.

Besides the holes 11 the division wall 10 is provided with a number of small perforations 13, through which any steam-bubbles which may find their way back into the water-space can escape to the steam-space of the lower compartment.

The aim of the modification of my invention, as illustrated in Figs. 3 and 4, is to obtain a steam generator with large water spaces, to which end the individual compartments are enlarged until they surround the fire-grate A on all sides and thus replace the otherwise necessary brick-work. For practical reasons the compartments of this modification are built up of sections or divisions united by comparatively large nipples 15 placed at such heights in the several sections of the same compartment as to permit an unrestricted circulation of water and steam. This arrangement of the compartments simplifies the construction of the tubes 6 considerably, which here are replaced by the crosswise arranged straight tubes 14 communicating with their lower ends with the water space of a compartment-section lying at one side of the fire-grate A and with their other ends with the steam space of a compartment-section lying opposite the former, so that an energetic water circulation must take place from the right to the left and vice versa.

The nipples 15 connect the several sections of one compartment with each other in such a manner, that the water entering one com-

partment by one over-flow pipe 16 must pass through all its sections before it can flow through another over-flow pipe 16 to the next compartment lying on a lower plane.

5 I claim:—

1. A steam generator comprising a plurality of superposed compartments having separated steam and water spaces, slanting tubes communicating with one end with the water space and with the other with the steam space of said compartments, and baffle-plates arranged in front of the ends of said tubes communicating with the water spaces of said compartments.

2. A steam generator comprising a plurality of superposed compartments having separated steam and water spaces, slanting tubes communicating with their lower ends with the water space and with their upper ends with the steam space of said compartments, baffle-plates arranged in all compartments but the lowermost in front of the ends of the tubes communicating with the water spaces of said compartments to prevent steam from reëntering said water spaces,

and a perforated division wall in the water space of said lowermost compartment.

3. A steam generator comprising a plurality of superposed compartments arranged in sections around the fire-grate and provided with separated steam and water spaces, slanting tubes communicating with their lower ends with the water space of one section of a compartment and with their upper ends with the steam space of another section of the same compartment, baffle plates arranged in all compartments but the lowermost in front of the ends of the tubes communicating with the water spaces of said compartments, and a division wall provided with perforations for the passage of steam formed before the water circulation of the steam generator has set in.

In testimony whereof I have signed my name to this specification in the presence of two subscribing witnesses.

JEAN VAN OOSTERWYCK

Witnesses:

W. SCHADCEK,  
JULUN MOUTVAST.