

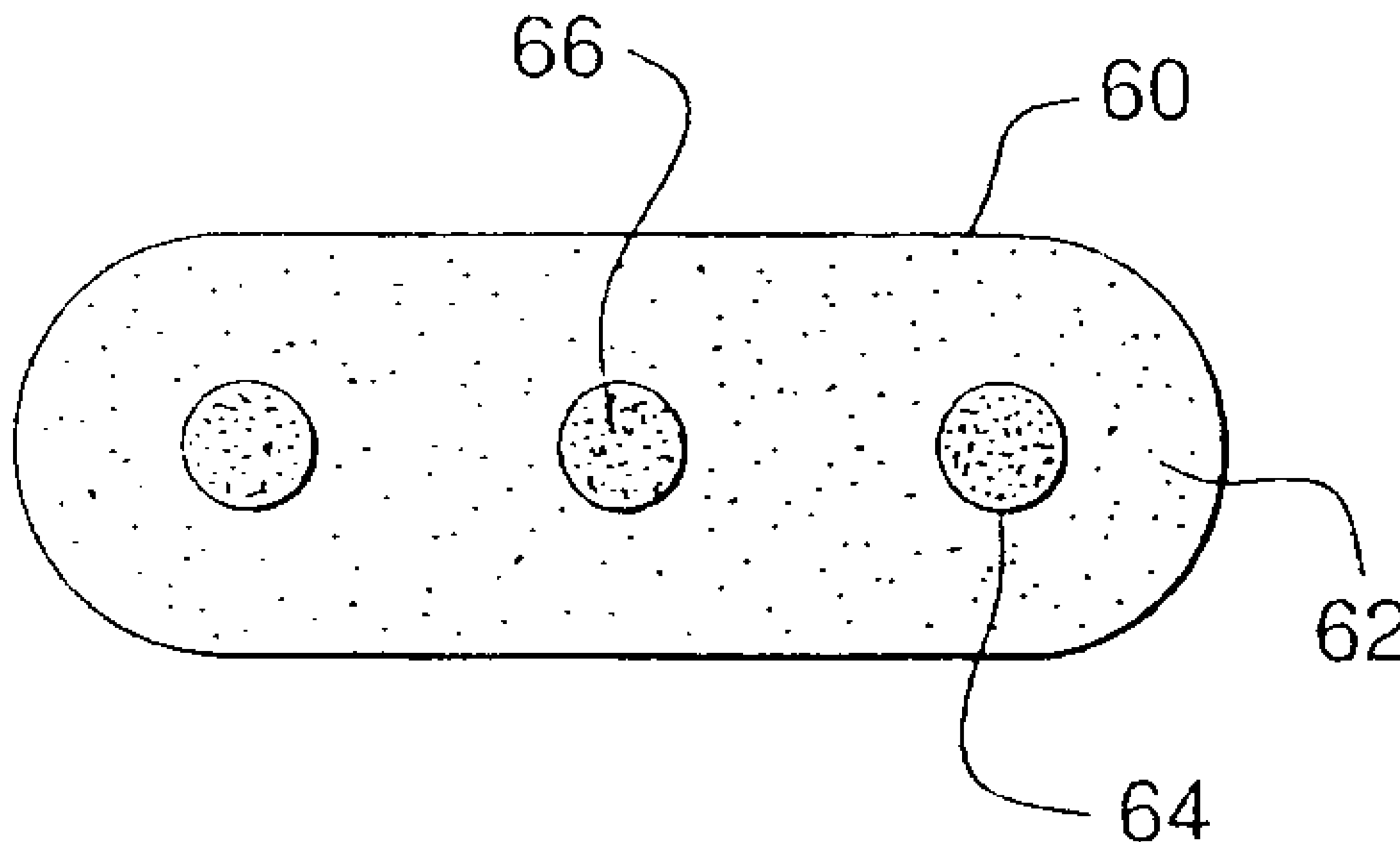

(22) Date de dépôt/Filing Date: 2003/12/18
 (41) Mise à la disp. pub./Open to Public Insp.: 2004/07/29
 (62) Demande originale/Original Application: 2 505 661
 (30) Priorité/Priority: 2003/01/10 (US10/339,977)

(51) Cl.Int./Int.Cl. *A61K 9/00* (2006.01)
 (71) Demandeur/Applicant:
 MUTUAL PHARMACEUTICAL COMPANY, INC., US
 (72) Inventeur/Inventor:
 ROBERTS, RICHARD H., US
 (74) Agent: SMART & BIGGAR

(54) Titre : FORME POSOLOGIQUE A INNOCUITE PHARMACEUTIQUE
 (54) Title: PHARMACEUTICAL SAFETY DOSAGE FORMS



(57) **Abrégé/Abstract:**

The invention provides a pharmaceutical safety dosage form comprising a pharmaceutical and an antagonist for said pharmaceutical wherein said antagonist comprises an emetic agent and has bioavailability only when said pharmaceutical safety dosage form is disrupted, and wherein the pharmaceutical is a blood pressure-lowering agent and the antagonist optionally further comprises a sympathomimetic. The invention also provides a pharmaceutical safety dosage form comprising a pharmaceutical and an antagonist for said pharmaceutical wherein said antagonist has bioavailability only when said pharmaceutical safety dosage form is disrupted, and wherein the pharmaceutical is a blood pressure-lowering agent and the antagonist is a sympathomimetic. The pharmaceutical safety dosage forms of the present invention are useful for providing pharmaceutical ingredients in forms which can minimize the effects of abusive or otherwise inappropriate use of the pharmaceutical ingredients.

75592-9D

PHARMACEUTICAL SAFETY DOSAGE FORMS

Abstract

The invention provides a pharmaceutical safety dosage form comprising a pharmaceutical and an antagonist for said pharmaceutical wherein said antagonist
5 comprises an emetic agent and has bioavailability only when said pharmaceutical safety dosage form is disrupted, and wherein the pharmaceutical is a blood pressure-lowering agent and the antagonist optionally further comprises a sympathomimetic. The invention also provides a pharmaceutical safety dosage form comprising a pharmaceutical and an antagonist for said pharmaceutical wherein said
10 antagonist has bioavailability only when said pharmaceutical safety dosage form is disrupted, and wherein the pharmaceutical is a blood pressure-lowering agent and the antagonist is a sympathomimetic. The pharmaceutical safety dosage forms of the present invention are useful for providing pharmaceutical ingredients in forms which can minimize the effects of abusive or otherwise inappropriate use of the
15 pharmaceutical ingredients.

75592-9D

PHARMACEUTICAL SAFETY DOSAGE FORMS

This is a divisional application of Canadian Patent Application No. 2,505,661 filed December 18, 2003.

Related Cases

5 **[0001]** This application claims priority to U.S. Serial No. 10/339,977, filed on January 10, 2003, entitled "Pharmaceutical Safety Dosage Forms".

Field Of The Invention

[0002] The present invention relates to the field of pharmaceutical safety dosage forms.

10 The subject matter of this divisional application is directed to pharmaceutical safety dosage forms comprising a blood pressure-lowering agent as the pharmaceutical.

The subject matter of the parent application has been restricted to pharmaceutical safety dosage forms comprising a sympathomimetic as the
15 pharmaceutical. However, it should be understood that the expression "the invention" and the like, when used herein, encompasses the subject matter of both the parent and this divisional application.

Background Of The Invention

[0003] Many pharmaceuticals are prone or potentially subject to misuse or
20 abuse when the intended dosing instructions are ignored and/or the written instructions are disregarded. For example, it is well known that sustained-release narcotics, such as OXYCONTIN[®] ER tablets (supplied by Perdue Pharma), are prone to abuse and misuse when their dosage units are broken, chewed, crushed, dissolved, or otherwise disrupted, rather than being taken whole as intended. Other narcotic and analgesic drugs are liable
25 to similar misuse. Other types of drugs, including those which are not amenable to abuse, may, nonetheless, be inappropriately used. Such inappropriate use can lead to adverse reactions in

75592-9D

persons so using the drugs and can give rise to adverse reactions and even death. One example of this is the inappropriate use of metformin sustained-release (e.g., GLUCOPHAGE[®] XR, metformin hydrochloride extended-release tablets supplied by Bristol-Myers Squibb), a common diabetes drug. If metformin sustained-release is chewed, or the tablets otherwise disrupted prior to ingestion, rather than the tablets being swallowed whole, dangerous lowering of a person's blood glucose level may result. Very large numbers of pharmaceuticals may be inappropriately ingested in this way and a method for reducing or eliminating the undesired effects has long been desired.

[0004] Many pharmaceutical products, which have been introduced into the pharmaceutical market in an immediate-release tablet or capsule form, have subsequently been reformulated into a sustained-release form. The sustained-release form has provided the advantages of more convenient dosing schedules, increased patient compliance, more even blood levels, improved therapeutic activity, or others. Typically, the dosage of active pharmaceutical ingredient in these sustained-release formulations is greater than the dosage of the corresponding immediate-release formulation. This presents the danger of "dumping" in which the sustained-release mechanism fails, either intentionally or unintentionally, so that potentially dangerous dosages of the active pharmaceutical ingredient (agonist) are delivered to the patient causing dangerously high blood levels of the agonist. For example, the *Physicians' Desk Reference (PDR)*, 56th Edition, states for GLUCOTROL[®] XL Extended Release Tablets (supplied by Pfizer), under "Information for Patients", that "Patients should be informed that GLUCOTROL XL Extended Release Tablets should be swallowed whole. Patients should not chew, divide, or crush tablets." For the product RITALIN-SR[®] (supplied by Novartis) under "DOSAGE AND ADMINISTRATION", it is written, "Ritalin-SR tablets must be swallowed whole and never crushed or chewed." For OXYCONTIN[®] ER tablets (supplied by Perdue Pharma) there has been much recent controversy and numerous

75592-9D

published reports of narcotic abuse through mechanical disruption of the sustained-release mechanism thereby enabling the abuser to receive a relatively larger immediate dose of narcotic.

[0005] Some attempts at providing dosage forms for preventing abuse of narcotics have been offered by the prior art. For example, U.S. Patent No. 4,457,933, Gordon et al., discusses both oral and parenteral abuse of strong analgesics, such as oxycodone, propoxyphene and pentazocine. Gordon et al. discuss oral administration of compositions containing specific ratios of oxycodone to naloxone, a narcotic antagonist. According to Gordon et al., the antagonist, naloxone, is supplied in an amount to deter either oral or parenteral abuse of an analgesic without substantially affecting the analgesic activity. Gordon et al., therefore, contemplates that the antagonist be absorbed into the blood in normal use along with the analgesic.

[0006] U.S. Patent No. 5,375,957 in the name of Kaiko et al. recognizes that oral and parenteral abuse of oral opioid formulations can occur by self-administration of more than the prescribed oral dosage. Kaiko et al. discusses an appropriate ratio between analgesic agonist and antagonist in such dosage forms to ensure analgesic efficacy is maintained. Thus, Kaiko et al. contemplates that the antagonist be absorbed into the blood in normal use along with the agonist. Kaiko et al. distinguishes itself over prior art that teaches inclusion of antagonists in oral opioid analgesic dosage forms, which are themselves not orally active, but which counteract the analgesic effects of the opioid upon parenteral administration. As an example, Kaiko et al. describes the commercially available combination of pentazocine and naloxone, wherein the amount of naloxone does not interfere with the pentazocine upon oral administration. As such, it is understood that the antagonist would still be absorbed into the blood in normal use along with the agonist, but would not provide any pharmacological activity.

75592-9D

[0007] Pharmaceutical dosage forms that permit absorption into the blood of an antagonist are inefficient because of the resulting potential to hinder the activity of the agonist during normal use. This limits the amount of antagonist that can be used. This also limits the potential amount of antagonist activity that can be incorporated into the dosage form to less than the amount of activity that will substantially inhibit the agonist activity. Even if, as in Gordon et al., the antagonist, naloxone, can be present in amounts that are not orally active, this may not be possible or desirable with antagonists for other drugs. Also, even if the antagonist is not orally active, it may still be absorbed by the blood and impact the patient during normal use of the dosage form. Additionally, as in Gordon et al., if the antagonist is inactive with oral use then it cannot provide protection against dumping of the agonist if the sustained-release tablet is mechanically disrupted. Furthermore, lack of oral activity may not deter oral abuse.

[0008] There remains a great need for dosage forms which can minimize or eliminate the effects of abusive or otherwise inappropriate use of pharmaceuticals. A need exists for dosage forms which may be employed for the delivery of a wide range of drugs and which do not require the coadministration of a separate second pharmaceutically active dosage unit in addition to the desired pharmaceutical. Dosage forms which ensure the safe administration of drugs without unnecessarily loading the bloodstream of a person taking the drug with additional dosage units are objects of this invention. A further object is to provide dosage forms which block an avenue of abusive value to a person in possession of the dosage unit. Other objects will become apparent from a review of the present specification.

Summary Of The Invention

[0009] Pharmaceutical safety dosage forms are provided by the present invention. Such pharmaceutical safety dosage forms include a pharmaceutical as well as an antagonist for the pharmaceutical. In normal use, that is when the dosage forms are administered or

75592-9D

taken by the person in need of drug treatment, the antagonist has no significant bioavailability. The antagonist has significant bioavailability only when the pharmaceutical safety dosage form is disrupted. Disruption of the dosage form means in this context the mechanical, chemical or other alteration of the dosage form in such a fashion as to release or make biologically available the antagonist. Disruption does not mean the dissolution of the dosage form or its delivery of the pharmaceutical in accordance with the intended mechanism of use of the dosage form.

[0010] The pharmaceutical safety dosage forms of the present invention can be administered orally, parenterally, rectally, vaginally, transdermally, via aerosol, via nasal spray, or otherwise such as via implantation. In connection with each route of administration, a normal mechanism of delivery of the pharmaceutical is intended consistent with good medical and pharmaceutical practices. Delivery of the pharmaceutical in any of these intended ways for the dosage forms of the invention does not deliver a substantial amount of the antagonist into the bloodstream. Rather, the antagonist is maintained in such a way as not to be substantially bioavailable via such intended method of administration. In short, it is intended that the antagonist "pass through" the patient and be substantially eliminated thereby. Thus, the antagonist is intended not to become bioavailable to the patient and not to require systemic inactivation or excretion therefrom. The overall loading of active compounds is, thus, minimized and limited to only the intended pharmaceutical when the dosage form is used as intended.

[0011] The present invention generally contemplates placing one or more antagonist pharmaceutical products within the dosage formulation of the agonist pharmaceutical product so that, under normal conditions, the antagonist is substantially not bioavailable. However, disruption of the formulation, through any of a variety of means, will release the antagonist thereby diminishing the effects of the agonist. For example, for the case of OXYCONTIN[®]

75592-9D

(supplied by Perdue Pharma) Extended Release tablets abuse, narcotic abusers are crushing the tablets to disrupt the sustained-release mechanism thereby gaining a large immediate dose of narcotic. This invention contemplates, in one example, placing a narcotic antagonist in coated beads in OXYCONTIN[®] (supplied by Perdue Pharma) Extended Release tablets for which the coating maintains the beads intact throughout the digestive system, under normal use, thereby blocking any significant bioavailability of the antagonist. However, when the narcotic abuser crushes the tablets, the abuser will also crush the beads thereby exposing the antagonist within the beads to dissolution in the gastrointestinal tract thereby facilitating bioavailability of the antagonist. There are numerous such examples including, but not limited to, the following: blood glucose lowering drugs such as metformin (e.g., GLUCOPHAGE[®] XR supplied by Bristol-Myers Squibb) or glipizide (e.g., GLUCOTROL XL[®] Extended Release Tablets supplied by Pfizer) containing beads of a hyperglycemic agent such as epinephrine or others; anti-hypertensive drugs such as propranolol (e.g., INDERAL[®] LA Long-Acting capsules supplied by Wyeth-Ayerst), metoprolol (e.g., TOPROL-XL[®] supplied by AstraZeneca), nifedipine (e.g., PROCARDIA XL[®] Extended Release tablets supplied by Pfizer, ADALAT[®] CC supplied by Bayer), diltiazem (e.g., CARDIZEM[®] CD supplied by Biovail), or nisoldipine (e.g., SULAR[®] supplied by AstraZeneca) containing beads of antagonist sympathomimetic drugs such as epinephrine or others; methylphenidate (e.g., RITALIN-SR[®] tablets supplied by Novartis) containing an adrenergic beta blocking drug in beads; any antihistamine with a sympathomimetic decongestant such as cetirizine HCl/pseudoephedrine HCl (e.g., ZYRTEC-D 12Hour[™] Extended Relief tablets supplied by Pfizer), fexofenadine HCl/pseudoephedrine HCl (ALLEGRA-D[®] Extended-Release tablets supplied by Aventis), or others containing beads containing one or more adrenergic beta receptor blocker drugs; any sustained-release drug

75592-9D

could contain an emetic agent within the normally non-bioavailable beads; and numerous other possibilities.

[0012] In all of these cases, the effects of the dumping of the active ingredient, whether through
5 intentional abuse, unintentional misuse, or other mechanism could be offset by the resultant release of the antagonist thereby undermining the motivation for abuse or protecting the patient against the harmful effects of dumping of the intended dose.

10 According to one aspect of the present invention, there is provided a pharmaceutical safety dosage form comprising a pharmaceutical and an antagonist for said pharmaceutical wherein said antagonist comprises an emetic agent and has significant bioavailability only when said
15 pharmaceutical safety dosage form is disrupted.

According to another aspect of the present invention, there is provided a pharmaceutical safety dosage form comprising a pharmaceutical contained within a first microdosage form, said first microdosage form being adapted
20 for release of said pharmaceutical within a patient, together with an antagonist for said pharmaceutical, said antagonist comprising an emetic agent and being contained within a second microdosage form, said second microdosage form being substantially insoluble in gastric fluid.

25 According to still another aspect of the present invention, there is provided a pharmaceutical safety dosage form comprising a pharmaceutical contained within a first plurality of particulated forms, said first particulated forms being adapted for release of said pharmaceutical
30 within a patient, together with an antagonist for said pharmaceutical, said antagonist comprising an emetic agent

75592-9D

and being contained within a second plurality of particulated forms, said second particulated forms being substantially insoluble in gastric fluid.

According to yet another aspect of the present invention, there is provided a pharmaceutical safety dosage form comprising a pharmaceutical contained within a microdosage form, said microdosage form being adapted for release of said pharmaceutical within a patient, together with an antagonist for said pharmaceutical, said antagonist comprising an emetic agent and being contained within a plurality of particulated dosage forms, said particulated dosage forms being substantially insoluble in gastric fluid.

According to a further aspect of the present invention, there is provided a pharmaceutical safety dosage form comprising a pharmaceutical contained within a plurality of particulated forms, said particulated forms being adapted for release of said pharmaceutical within a patient, together with an antagonist for said pharmaceutical, said antagonist comprising an emetic agent and being contained within a microdosage form, said microdosage form being substantially insoluble in gastric fluid.

According to yet a further aspect of the present invention, there is provided a pharmaceutical safety dosage form comprising a pharmaceutical in a first form adjacent to an antagonist for said pharmaceutical in a second form wherein said antagonist comprises an emetic agent and has significant bioavailability only when said pharmaceutical safety dosage form is disrupted.

According to still a further aspect of the present invention, there is provided a method of administering a

75592-9D

pharmaceutical comprising: providing a pharmaceutical safety dosage form comprising a pharmaceutical in a first form, said first form providing a prescribed bioavailability; and providing an antagonist for said pharmaceutical in a second
5 form, said antagonist comprising an emetic agent and said second form providing insignificant bioavailability when administered; and wherein disruption to said pharmaceutical safety dosage form may result in significant bioavailability of said antagonist.

10 According to another aspect of the present invention, there is provided a method of delivering a drug to a patient comprising placing said drug into a pharmaceutical safety dosage form further comprising an antagonist for said drug, said antagonist comprising an
15 emetic agent and being insubstantially bioavailable when said dosage form is not disrupted; and administering said safety dosage form to the patient.

 According to yet another aspect of the present invention, there is provided a method of delivering a
20 narcotic to a patient comprising placing said narcotic into a pharmaceutical safety dosage form further comprising a narcotic antagonist and an emetic agent, said narcotic antagonist and said emetic agent being insubstantially bioavailable when said dosage form is not disrupted; and
25 administering said safety dosage form to the patient.

 According to another aspect of the present invention, there is provided a method of delivering a sympathomimetic to a patient comprising placing said
30 sympathomimetic into a pharmaceutical safety dosage form comprising an adrenergic beta blocker, said adrenergic beta blocker being insubstantially bioavailable when said dosage

75592-9D

form is not disrupted; and administering said safety dosage form to the patient.

According to still another aspect of the present invention, there is provided a method of delivering a blood pressure-lowering medication to a patient comprising placing
5 said blood pressure-lowering medication into a pharmaceutical safety dosage form comprising a sympathomimetic, said sympathomimetic being insubstantially bioavailable when said dosage form is not disrupted; and
10 administering said safety dosage form to the patient.

According to yet another aspect of the present invention, there is provided a method of delivering a hypoglycemic agent to a patient comprising placing said hypoglycemic agent into a pharmaceutical safety dosage form
15 comprising a hyperglycemic agent, said hyperglycemic agent being insubstantially bioavailable when said dosage form is not disrupted; and administering said safety dosage form to the patient.

According to a further aspect of the present invention, there is provided a method of making a
20 pharmaceutical safety dosage form comprising a pharmaceutical and an antagonist for said pharmaceutical wherein said antagonist comprises an emetic agent that has significant bioavailability only when said pharmaceutical
25 safety dosage form is disrupted.

According to yet a further aspect of the present invention, there is provided a pharmaceutical safety dosage form comprising a sympathomimetic pharmaceutical and an antagonist for said pharmaceutical wherein said antagonist
30 has significant bioavailability only when said pharmaceutical safety dosage is disrupted.

75592-9D

According to still a further aspect of the present invention, there is provided a pharmaceutical safety dosage form comprising a blood pressure-lowering pharmaceutical and an antagonist for said pharmaceutical wherein said
5 antagonist has significant bioavailability only when said pharmaceutical safety dosage form is disrupted.

According to another aspect of the present invention, there is provided a pharmaceutical safety dosage form comprising a hypoglycemic pharmaceutical and an
10 antagonist for said pharmaceutical wherein said antagonist has significant bioavailability only when said pharmaceutical safety dosage form is disrupted.

According to one aspect of the present invention, there is provided a pharmaceutical safety dosage form
15 comprising a pharmaceutical and an antagonist for said pharmaceutical wherein said antagonist comprises an emetic agent and has bioavailability only when said pharmaceutical safety dosage form is disrupted, and wherein: i. the pharmaceutical is a sympathomimetic or a sympathomimetic and
20 an antihistamine and the antagonist optionally further comprises an adrenergic beta-blocker, ii. the pharmaceutical is a blood pressure-lowering agent and the antagonist optionally further comprises a sympathomimetic, or iii. the pharmaceutical is a hypoglycemic agent and the antagonist
25 optionally further comprises a hyperglycemic agent.

According to another aspect of the present invention, there is provided a pharmaceutical safety dosage form comprising a pharmaceutical and an antagonist for said pharmaceutical wherein said antagonist has bioavailability
30 only when said pharmaceutical safety dosage form is disrupted, and wherein i. the pharmaceutical is a

75592-9D

sympathomimetic or a sympathomimetic and an antihistamine, and the antagonist is an adrenergic beta-blocker, ii. the pharmaceutical is a blood pressure-lowering agent, and the antagonist is a sympathomimetic, or iii. the pharmaceutical is a hypoglycemic agent, and the antagonist is a hyperglycemic agent.

5 According to one aspect of the present divisional application, there is provided a pharmaceutical safety dosage form comprising a pharmaceutical and an antagonist for said pharmaceutical wherein said antagonist comprises an emetic agent and has bioavailability only when said pharmaceutical safety dosage form is disrupted, and wherein the pharmaceutical is a blood pressure-lowering agent and
10 the antagonist optionally further comprises a sympathomimetic.

 According to another aspect of the present divisional application, there is provided a pharmaceutical safety dosage form comprising a pharmaceutical and an antagonist for said pharmaceutical wherein said antagonist has bioavailability only when said pharmaceutical safety dosage form is disrupted, and wherein the
15 pharmaceutical is a blood pressure-lowering agent and the antagonist is a sympathomimetic.

Brief Description Of The Drawings

[0013] Figure 1 shows a dosage form of the invention containing pluralities of microdosage forms.

20 **[0014]** Figure 1A depicts two different types of bead types of microdosage forms.

[0015] Figure 1B shows a multi-layered bead for use in one embodiment of the invention.

[0016] Figure 2 depicts an osmotic drug dosage form in accordance
25 with the invention.

75592-9D

[0017] Figure 3 shows a dosage form of the invention containing microdosage forms and particulated forms.

[0018] Figure 4 shows a dosage form of the invention containing two different types of microdosage forms.

5 **[0019]** In accordance with the invention, antagonist is delivered from the dosage form, (i.e., becomes bioavailable), only when the dosage form is physically or otherwise disrupted through use in a manner not intended by the drug manufacturer. For example, by reference to only one type of pharmaceutical, with oxycodone sustained-release, for which the present dosage forms are applicable, in
10 normal use, the oxycodone is delivered over a period of time to a patient ingesting a dosage form so as to provide extended narcotic effect to such patient. An antagonist for the narcotic, naloxone, is present in the dosage form, but is

75592-9D

not released from the dosage form; it does not become bioavailable, in normal use. However, if the oxycodone dosage form is disrupted, e.g. physically comminuted, in an attempt to release immediately the entire amount of the narcotic in order to abuse the drug, the antagonist, naloxone, is also released. The naloxone is preferably present in an amount sufficient to interfere with the narcotic effect of the oxycodone, thus frustrating the attempted abuse of the drug.

[0020] The present dosage forms are amenable to the delivery of a wide variety of narcotic and non-narcotic drugs in a manner having improved safety. The only requirement is a practical one. Thus, a drug which is capable of abuse or of significant adverse effect if inappropriately ingested during or following disruption of the dosage form must be one which has an antagonist. In this context, an antagonist is preferably a compound or composition which is capable of interfering or negating all or some of the effects of the therapeutic drug. This may be achieved either biochemically, physically, physiologically, or otherwise. Thus, while the exemplary narcotic antagonist, naloxone, operates biochemically, it is believed, through interfering with a biochemical (receptor) pathway for narcotics, an effective antagonist, in the context of this invention, may act otherwise, e.g. through stimulation of an excretion or breakdown mechanism for the drug. The mechanism of action of antagonists which may be employed herein is not intended to be limiting in any way. Any compound, group of compounds or composition which can interfere effectively with the action of a drug may be considered to be an antagonist for the drug, providing the overall objectives of this invention are met.

[0021] While physical disruption of dosage forms, e.g. comminution or "grinding them up," is an important path undertaken for the abuse or inappropriate use of drugs, non-physical means may also be employed. Thus, dissolution in solvent systems in order to extract drug may be performed. It is preferred that the dosage forms of the present invention

75592-9D

release their antagonist component when subjected to such solvent action if the particular intended activity of the antagonist is to counteract the effects of this solvent disruption. Conceivably, a dosage form could be melted or sublimed to release a drug. In such cases, it may be preferred that dosage forms be available which can release antagonist under such conditions if this is the particular activity that is intended to be counteracted by inclusion of the antagonist in the dosage form. The antagonist can be formulated to protect against one or more such disruption activities.

[0022] Many pharmaceuticals are provided in capsule dosage forms containing within them microdosage forms. One embodiment of the present invention provides a pharmaceutical and an antagonist for the pharmaceutical in a dosage form where each is contained within microdosage forms, e.g., coated beads, mini tablets, and tablets. Thus, for example, the beads containing the drug are coated or formulated so as to release the drug on an intended time profile. The beads containing the antagonist, however, are either formulated or coated so as to prevent significant bioavailability of the antagonist when the dosage form is consumed as intended. Specific coatings which can attain the foregoing objectives are numerous and well-known to pharmaceutical chemists and formulators. Their identity and use in achieving coatings or formulations in accordance with the present requirements are not a central part of this invention and it is to be understood that all such coatings and formulations are comprehended hereby. It is understood, for example, that it may be desirable in some formulations to use only a single coating, whereas it may be desirable in other formulations to use multiple coatings, and the embodiments of the present invention are not intended to be limited thereby.

[0023] An exemplary, but by no means exhaustive, compilation of coatings and formulations for solid dosage forms, and the like is contained within *Remington: The Science and Practice of Pharmacy* by Alfonso R. Gennar, editor, (19th edition 2000) (Chapters 45-

75592-9D

46) and *Pharmaceutical Dosage Forms and Drug Delivery Systems* by Howard C. Ansel, et al. (Chapters 6-7).

[0024] An exemplary dosage form employing beads in accordance with the foregoing discussion is presented in Figure 1. Figure 1 depicts a conventional capsule dosage form comprising a shell, 10 and containing pluralities of microdosage forms, e.g. beads, 12. There are preferably at least two different kinds of beads, beads (or other microdosage forms) containing the drug and beads (or other microdosage forms) containing antagonist. The drug-containing beads are formulated so as to release drug when administered to a patient in accordance with conventional practice. The antagonist-containing beads are formulated so as not to deliver antagonist to a patient in normal use. Thus, for example, as shown in Figure 1A, beads 16 can represent a formulated drug 24 within a saccharide, polymer, or other matrix designed to deliver the drug, e.g. in the small intestine of a patient. Another type of bead 14 comprises antagonist for the drug 20 coated by coating 22 the whole being formulated to resist antagonist delivery until all beads are eliminated from the patient, e.g. in the stool. As discussed, however, the drug-containing beads may be coated and the antagonist not coated as may be desired by the routineer in the art. Moreover, three or more different types of beads may be employed, for example, when extended-release of drug is desired or there are different active ingredients. As stated, the preparation of diverse types of beads and the use of a wide variety of coatings and formulation components is an advanced art and is well known to persons skilled in drug formulation. All such may find utility herein.

[0025] A further exemplification of the invention is shown in Figure 1B. The figure depicts a multi-layer microdosage form or bead 30. Drug 32 is coated by coating 34 designed to deliver the drug to a patient at a desired time and in a desired location, e.g. the stomach. The whole, in this embodiment, preferably surrounds a formulation of antagonist 36 for the

75592-9D

drug which is so formulated as not to release antagonist when ingested under normal conditions. Thus, the antagonist is designed to pass through the body of the patient unabsorbed.

[0026] If any of these exemplary embodiments are subjected to physical disruption, e.g. by being ground up, both the drug and the antagonist are likely to be released. The dosage forms are, thus, less amenable to abuse if crushed or chewed by a patient. Furthermore, such dosage forms provide protection against unexpected dosing upon crushing or chewing because the patient will receive both the unexpected dosing and the antagonist which will diminish the effect of the unexpected dosage. Increased resistance to abuse and overdose result.

[0027] Another exemplary dosage form using different types of microdosage forms is shown in Figure 4. Figure 4 presents a conventional capsule dosage form comprising a shell 70, and containing two different types of microdosage forms, e.g., tablets 74 and beads 78. It is understood that neither the drug nor its antagonist are limited to certain microdosage forms. Thus, in one instance, a drug 72 may be contained in tablets 74 which are formulated for time-release, and its antagonist 76 may be contained in beads 78 formulated or coated to not deliver the antagonist during normal use of the dosage form. On the other hand, it is possible that the drug may be contained in beads formulated for time-release and its antagonist may be contained in tablets coated to prevent significant bioavailability when the dosage form is used as intended.

[0028] Many pharmaceuticals are also provided in tableted or capsule dosage forms comprising some particulated forms of ingredients. A further embodiment of the present invention comprises a drug in the form of a powder, in an amorphous form or with one or more polymorphs, in tabletable form together with antagonist in a microdosage form such that it is substantially insoluble in gastric or other fluid. Thus, for example, a powdered drug,

75592-9D

along with excipients, such as fillers, binders, disintegration agents, lubricants, colorants, or other conventional adjuvants, is combined with one or more beads, mini tablets, powder, or other forms containing antagonist. The antagonist forms are formulated or coated in such a way as to render them substantially insoluble in the gastrointestinal tract or other locus of administration. An antagonist that is substantially insoluble in the human body, for example, is prevented from being released before the antagonist is excreted from the body. It is understood in the art that powders can be formulated so as to prevent dissolution in bodily fluids and/or prevent significant bioavailability. Solubility of polymorphs or solvates, for example, are dependent on the crystallized structure of the molecules, and thus, have different solubilities. Hence, certain polymorphs or solvates may be insoluble in the body, but readily soluble in specific solvents. The preparation of polymorphs or solvates are discussed by numerous patents on numerous molecules, e.g. U.S. Patent Nos. 6,472,563; 6,440,459; 6,337,422; 6,133,289; and 5,900,423. Also contemplated is using one or more polymorphic or solvate forms of one or more antagonists wherein the utilized polymorphic or solvate forms are not readily bioavailable under normal use.

[0029] In Figure 3, a tableted dosage form in accordance with one embodiment of the invention is provided. The tableted dosage form 60 is formed from powdered drug 62 together with conventional adjuvants, such as excipients and the like. Beads, mini tablets, or the like 64 comprising antagonist for the drug 66 are included within the tablet. Other variations of such tableted dosage forms may also be employed. It is understood that neither the drug nor its antagonist are limited to certain particulated forms or microdosage forms. Thus, a drug may be present in time-release powder form and its antagonist may be present as a polymorph which is insoluble in the body, but readily soluble in specific solvents. Furthermore, pharmaceutical safety dosage forms themselves are not limited in the types of microdosage forms or particulated forms contained therein. As such, a conventional capsule

75592-9D

dosage form, for example, may contain a drug in time-release powdered form and an antagonist to the drug in tableted form, shellacked to prevent bioavailability upon normal use of the dosage form.

[0030] A further dosage form in accordance with this invention is depicted in Figure 2. This is a type of osmotic pump drug delivery dosage form 40. Thus, a shell 41 contains a compartment containing drug 42 as well as a compartment containing an osmotic agent 50. The two compartments are preferably separated by a piston 48. Preferably, both the drug-containing compartment and the osmotic agent-containing compartment have an orifice sealed by plugs 46 and 52, respectively. Upon administration, such as oral administration, the plugs 46 and 52 dissolve, exposing both the drug-containing compartment and the osmotic agent-containing compartment to body fluid. Absorption of water by the osmotic agent with concomitant swelling pushes upon the piston 48, expelling the drug through the orifice to its compartment. The geometry of the dosage form, orifice sizes, identity of the drug and osmotic agent and other factors are typically designed and optimized for a desired delivery location and timing. The art of osmotic drug delivery is relatively mature and an extensive patent literature has arisen. Moreover, commercial sources for such dosage forms are available, e.g. the Alza Corporation. One exemplary patent showing such dosage forms is U.S. patent 6,132,420.

[0031] The present invention may be applied to such osmotic drug dosage forms. In one embodiment, shown in Figure 2, a formulation of antagonist, 54 surrounds the dosage form. In view of the importance of the orifices to operation of the dosage form, the antagonist formulation is generally kept away from those orifices as shown. Since osmotic drug delivery vehicles may take a diversity of physical shapes, the shape and location of antagonist will reflect such geometry. While, as shown, the antagonist formulation is one which does not release antagonist to the body of a person correctly ingesting the dosage form,

75592-9D

it may also be coated if preferred to achieve a similar result. In any event, physical or other disruption of the dosage form will release the antagonist as well as the drug. Another example could be coated beads of the antagonist that reside in one or more compartments of the osmotic drug delivery vehicle.

[0032] Another aspect of the present invention is a method of administering pharmaceuticals by providing pharmaceutical safety dosage forms that include a pharmaceutical and an antagonist for the pharmaceutical where the microdosage forms provide insignificant bioavailability when the dosage form is administered as intended.

[0033] Insignificant bioavailability in the context of this invention is intended to mean that the antagonist does not interfere with the drug in a meaningful way and that the person to whom the dosage form is administered is not burdened with a significant loading of antagonist.

[0034] Drug dosage forms of this invention are preferably administered through the alimentary canal orally or anally. Delivery otherwise to the body from outside of the digestive tract, parenteral administration, may also benefit from this invention and employs, e.g. subcutaneous, intravenous, intravaginal, intramuscular, transdermal, nasal, aerosol, or other routes of administration.

[0035] The use of the present pharmaceutical safety dosage forms is directly applicable to administration of drugs prone to drug abuse, such as narcotics and amphetamines. One combination of agonist and antagonist contemplated by the present invention includes narcotics and narcotic antagonists. Examples of narcotics include, but are not limited to, codeine, oxycodone, propoxyphene, pentazocine, and derivatives thereof. Examples of narcotic antagonists include, but are not limited to, naloxone, nalmefene, and derivatives thereof. Another combination of agonist and antagonist is sympathomimetics, e.g. amphetamines, and adrenergic beta blockers. Sympathomimetic agonists along with

75592-9D

antihistamines can also be combined with adrenergic beta blockers. Reference to derivatives of chemicals discussed herein include, but are not limited to, chemical derivatives and salts and bases thereof.

[0036] Drugs which are not prone to abuse may also be administered using the safety dosage forms hereof. Thus, drugs intended for sustained-release in the body can give rise to unpleasant and undesired reactions if over-administered. Thus, the disruption of dosage forms containing, e.g. diabetes drugs, blood pressure lowering drugs and many other types of pharmaceuticals can give rise to diabetic shock or shock-inducing low blood pressure. Such conditions can be fatal. Examples of diabetes drugs include, but are not limited to, hypoglycemic agents, and examples of antagonists to hypoglycemic agents include, but are not limited to, hyperglycemic agents. Examples of blood pressure-lowering drugs include, but are not limited to, adrenergic beta blockers, calcium channel blockers, and ACE inhibitors. Examples of antagonists to blood pressure-lowering drugs include, but are not limited to, sympathomimetics. Including antagonists for these drugs as taught hereby can guard against accidental overdose, if, for example, sustained-release tablets are chewed.

[0037] Furthermore, in accordance with the present invention, dosage forms can include any pharmaceutical combined with an emetic agent, e.g., ipecac, which is released upon disruption of the dosage forms.

[0038] While not intended to be limiting, an exemplary list of drugs (as bases or any salts thereof) and their antagonists are set forth which may find utility through delivery via the safety dosage forms of this invention.

DRUG	ANTAGONIST
Codeine, Oxycodone, Propoxyphene, Pentazocine, Buprenorphine, Morphine, Oxymorphone	Naloxone, Nalmefene, Naltrexone
Methamphetamine, amphetamine, dextroamphetamine, methylphenidate	Propranolol, Atenolol, Metoprolol, or other adrenergic beta blocker
Insulin, Metformin, Glipizide	Epinephrine, Glucagon
Propranolol, Metoprolol, Nifedipine,	Dopamine, Epinephrine or other

75592-9D

Diltiazem, Nisoldipine, Timolol Maleate	sympathomimetic
Methylphenidate	Adrenergic beta blocker
Cetirizine HCl/pseudoephedrine HCl, fexofenadine HCl/pseudoephedrine HCl	Adrenergic beta blocker
Any drug	Ipecac or other emetic agent

[0039] Other aspects of the invention will be apparent from review of the present specification and claims and all such falling within the spirit of the invention are comprehended hereby.

75592-9D

CLAIMS:

1. A pharmaceutical safety dosage form comprising

 a pharmaceutical and an antagonist for said pharmaceutical wherein
said antagonist comprises an emetic agent and has bioavailability only when said
5 pharmaceutical safety dosage form is disrupted, and wherein the pharmaceutical is a
blood pressure-lowering agent and the antagonist optionally further comprises a
sympathomimetic.
2. A pharmaceutical safety dosage form comprising

 a pharmaceutical and an antagonist for said pharmaceutical wherein
10 said antagonist has bioavailability only when said pharmaceutical safety dosage form
is disrupted, and wherein the pharmaceutical is a blood pressure-lowering agent and
the antagonist is a sympathomimetic.
3. The pharmaceutical safety dosage of claim 1 or 2, wherein said
pharmaceutical is adapted for time-release, or said antagonist further comprises an
15 insoluble coating, or both.
4. The pharmaceutical safety dosage form of claim 1 or 2, wherein said
bioavailability occurs upon mechanical disruption.
5. The pharmaceutical safety dosage form of claim 1 or 2, wherein said
bioavailability occurs upon extraction by a chemical.
- 20 6. The pharmaceutical safety dosage form of claim 1 or 2, adapted to be
administered orally.
7. The pharmaceutical safety dosage form of claim 1 or 2, adapted to be
administered rectally, parenterally, vaginally, transdermally, intranasally, or via
aerosol.

75592-9D

8. The pharmaceutical safety dosage form of claim 1 wherein said emetic agent is ipecac or derivatives thereof.
9. The pharmaceutical safety dosage form of claim 1 or 2, wherein said pharmaceutical comprises a blood pressure-lowering medication.
- 5 10. The pharmaceutical safety dosage form of claim 9, wherein said blood pressure-lowering medication is an adrenergic beta blocker, a calcium channel blocker, or an ACE inhibitor.
11. The pharmaceutical safety dosage form of claim 9 wherein said blood pressure-lowering medication is propranolol, metoprolol, nifedipine, diltiazem,
10 nisoldipine, timolol maleate, derivatives thereof, or combinations thereof.
12. The pharmaceutical safety dosage form of claim 1 wherein said antagonist further comprises a sympathomimetic.
13. The pharmaceutical safety dosage form of claim 1 or 2, wherein said sympathomimetic is dopamine, epinephrine, derivatives thereof, or combinations
15 thereof.
14. The pharmaceutical safety dosage form of any one of claims 1 to 13, wherein the pharmaceutical is contained within a first microdosage form, said first microdosage form being adapted for release of said pharmaceutical within a patient, and the antagonist for said pharmaceutical, said antagonist comprising an emetic
20 agent, is contained within a second microdosage form, said second microdosage form being substantially insoluble in gastric fluid.
15. The pharmaceutical safety dosage form of claim 14, wherein said pharmaceutical is adapted for time-release, or said second microdosage form comprises a coating which is substantially insoluble in gastric fluid, or both.
- 25 16. The pharmaceutical safety dosage form of claim 14, wherein said first microdosage form comprises beads, tablets, mini tablets, or combinations thereof; or

75592-9D

said second microdosage forms comprises beads, tablets, mini tablets, or combinations thereof; or both.

17. The pharmaceutical safety dosage form of any one of claims 1 to 13, wherein the pharmaceutical is contained within a first plurality of particulated forms, said first particulated forms being adapted for release of said pharmaceutical within a patient, and the antagonist for said pharmaceutical, said antagonist comprising the emetic agent, is contained within a second plurality of particulated forms, said second particulated forms being substantially insoluble in gastric fluid.

18. The pharmaceutical safety dosage form of claim 17, wherein said pharmaceutical is adapted for time-release, or said second plurality of particulated forms comprise a polymorph or a solvate which is substantially insoluble in gastric fluid, or both.

19. The pharmaceutical safety dosage form of claim 17, wherein said first plurality of particulated forms comprises a sustained-release powder.

20. The pharmaceutical safety dosage form of any one of claims 1 to 13, wherein the pharmaceutical is contained within a microdosage form, said microdosage form being adapted for release of said pharmaceutical within a patient, and the antagonist for said pharmaceutical, said antagonist comprising the emetic agent is contained within a plurality of particulated dosage forms, said particulated dosage forms being substantially insoluble in gastric fluid.

21. The pharmaceutical safety dosage form of claim 20, wherein said pharmaceutical is adapted for time-release, or said plurality of particulated forms comprise a polymorph which is substantially insoluble in gastric fluid, or both.

22. The pharmaceutical safety dosage form of claim 20, wherein said microdosage form comprises beads, tablets, mini tablets, or combinations thereof.

23. The pharmaceutical safety dosage form of any one of claims 1 to 13, wherein the pharmaceutical is contained within a plurality of particulated forms, said

75592-9D

particulated forms being adapted for release of said pharmaceutical within a patient, and the antagonist for said pharmaceutical, said antagonist comprising the emetic agent, is contained within a microdosage form, said microdosage form being substantially insoluble in gastric fluid.

5 24. The pharmaceutical safety dosage form of claim 23, wherein said plurality of particulated forms comprise a polymorph which is substantially insoluble in gastric fluid, or said microdosage form comprises a coating which is substantially insoluble in gastric fluid, or both.

10 25. The pharmaceutical safety dosage form of claim 23, wherein said microdosage form comprises beads, tablets, mini tablets, or combinations thereof.

15 26. The pharmaceutical safety dosage form according to any one of claims 1 to 13, wherein the pharmaceutical is in a first form adjacent to an antagonist for said pharmaceutical in a second form wherein said antagonist comprises the emetic agent and has bioavailability only when said pharmaceutical safety dosage form is disrupted.

27. The pharmaceutical safety dosage of claim 26, wherein said first form is time-release, or said second form comprises an insoluble coating, or both.

28. The pharmaceutical safety dosage form of claim 26, wherein said first form is substantially layered over said second form.

20 29. The pharmaceutical safety dosage form of claim 26, wherein said second form is substantially layered over said first form.

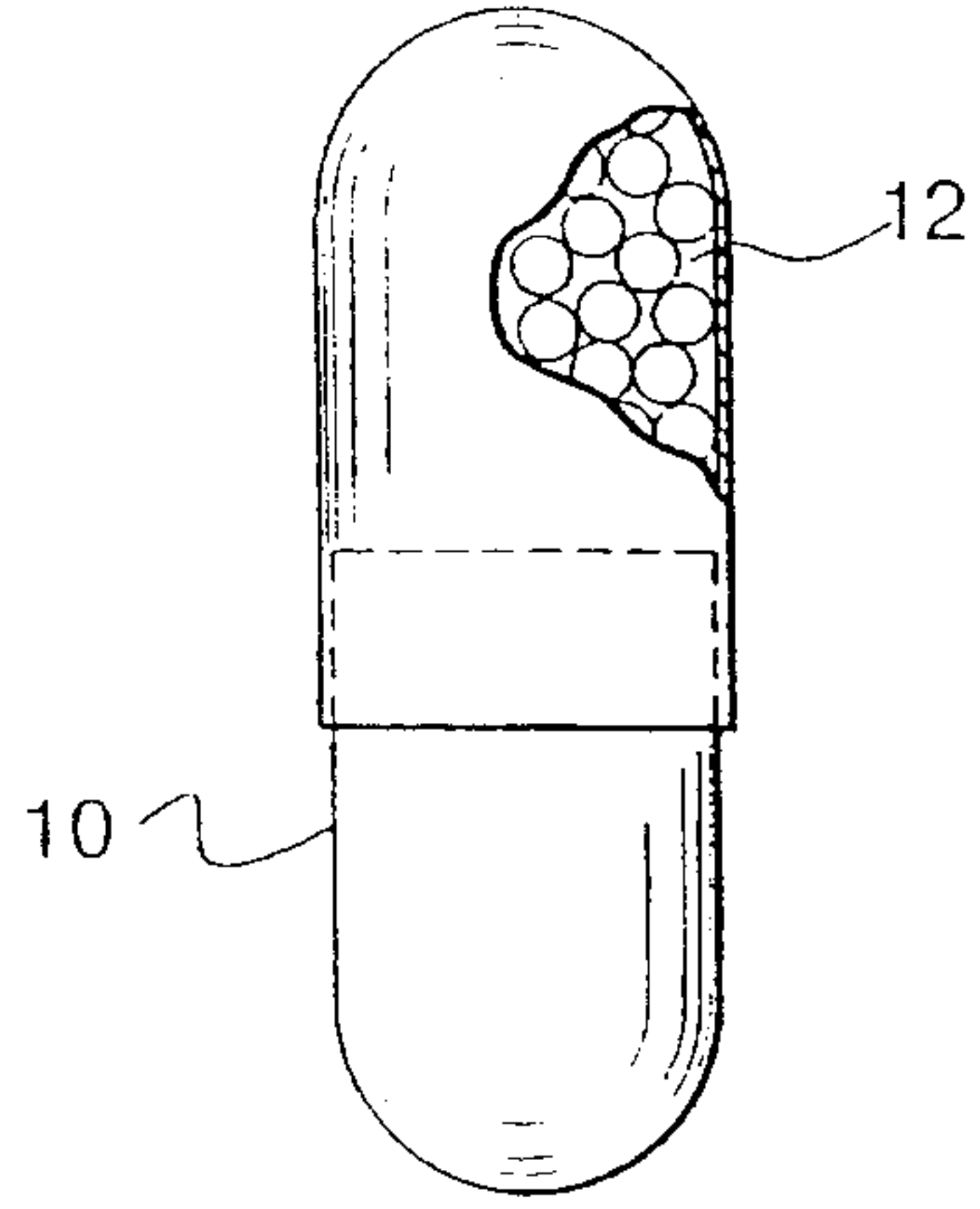

FIG. 1

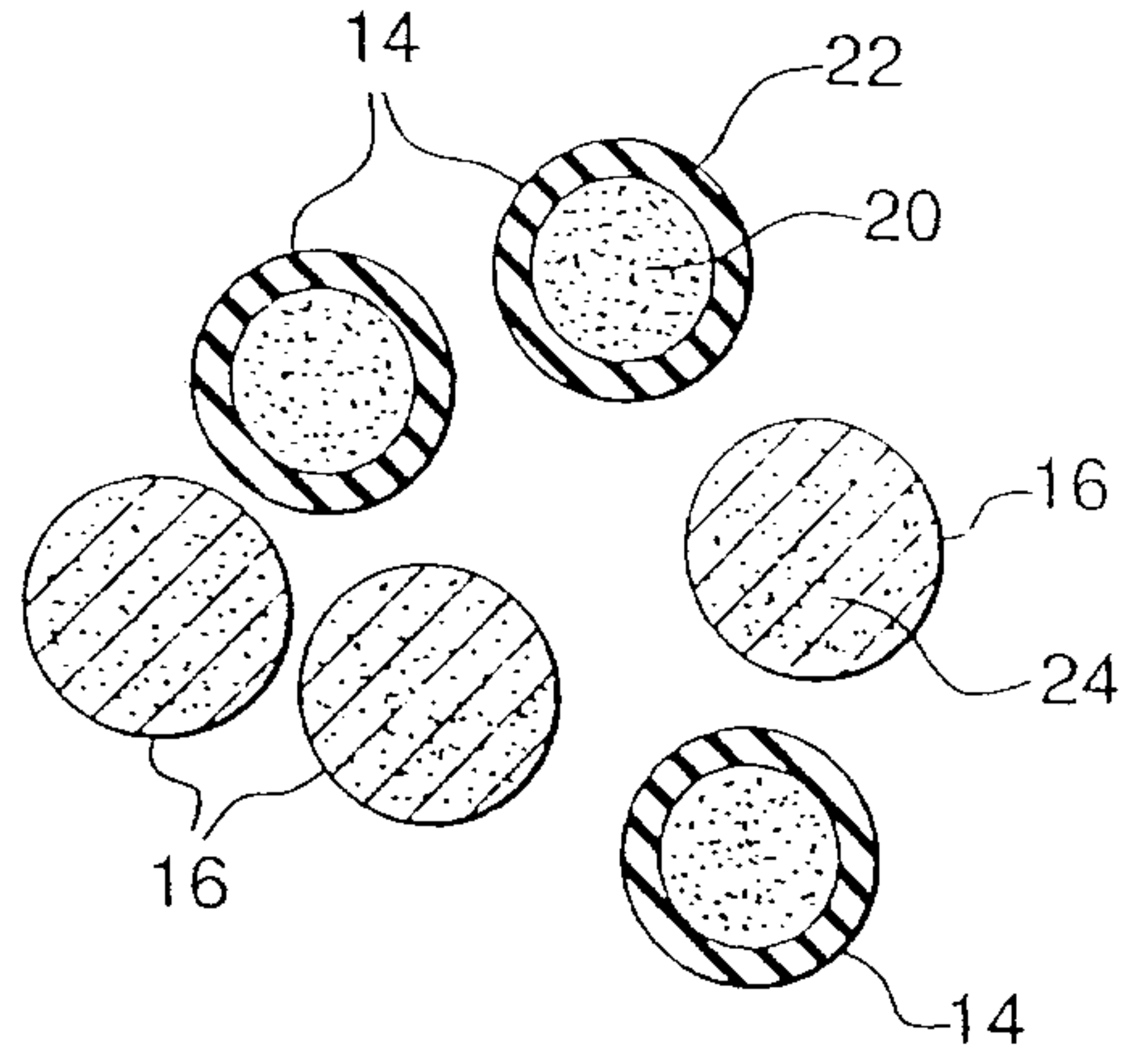

FIG. 1A

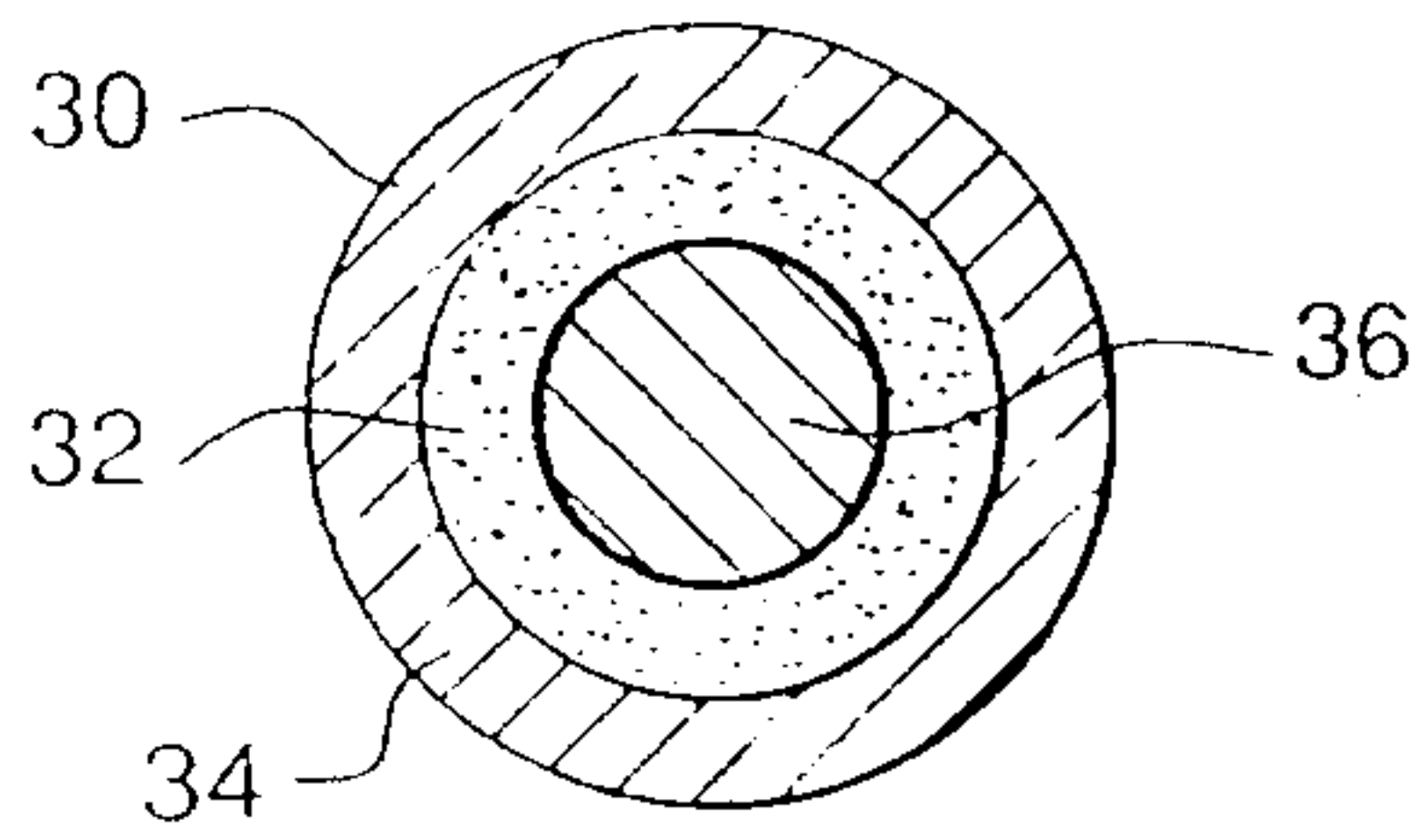

FIG. 1B

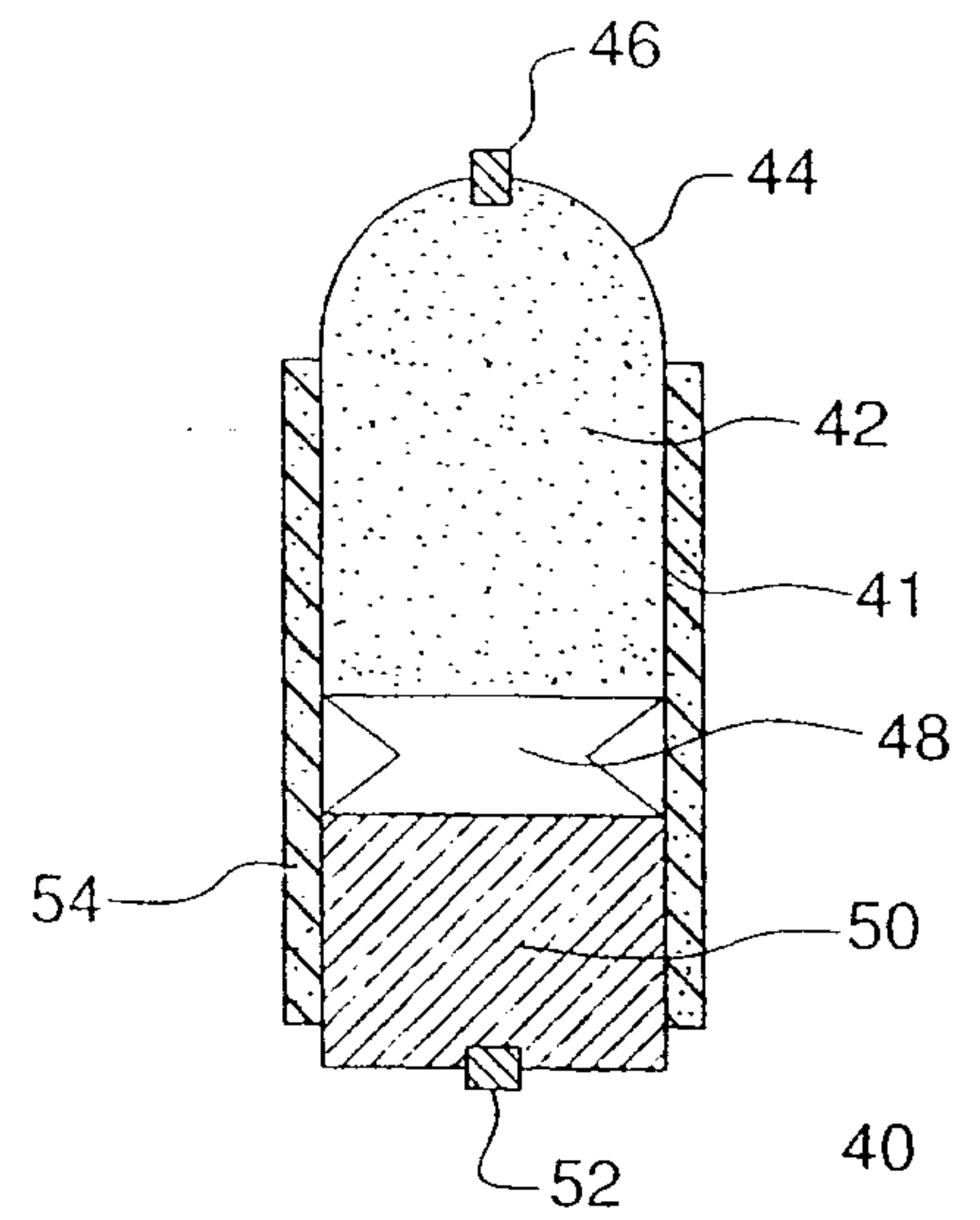

FIG. 2

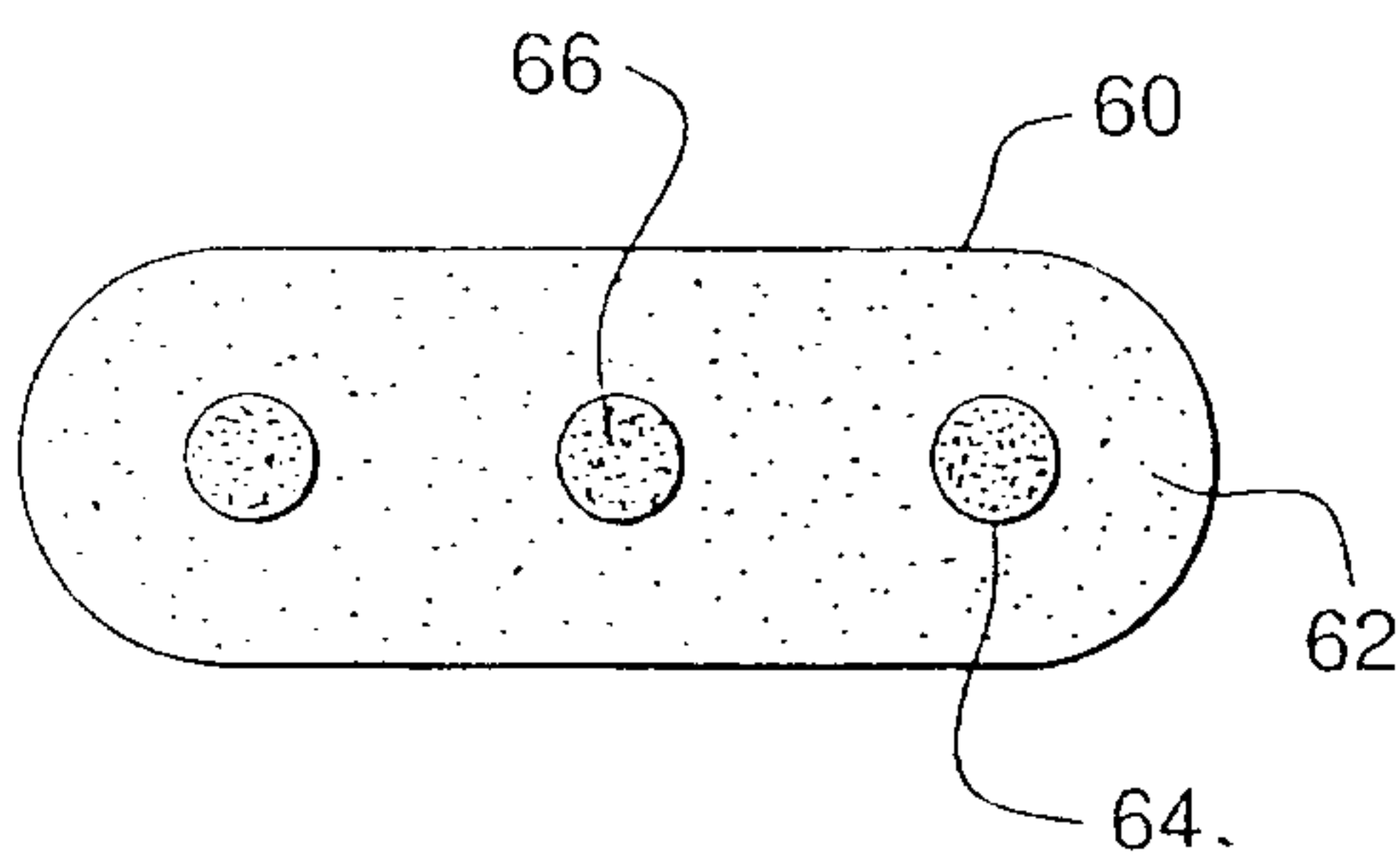

FIG. 3

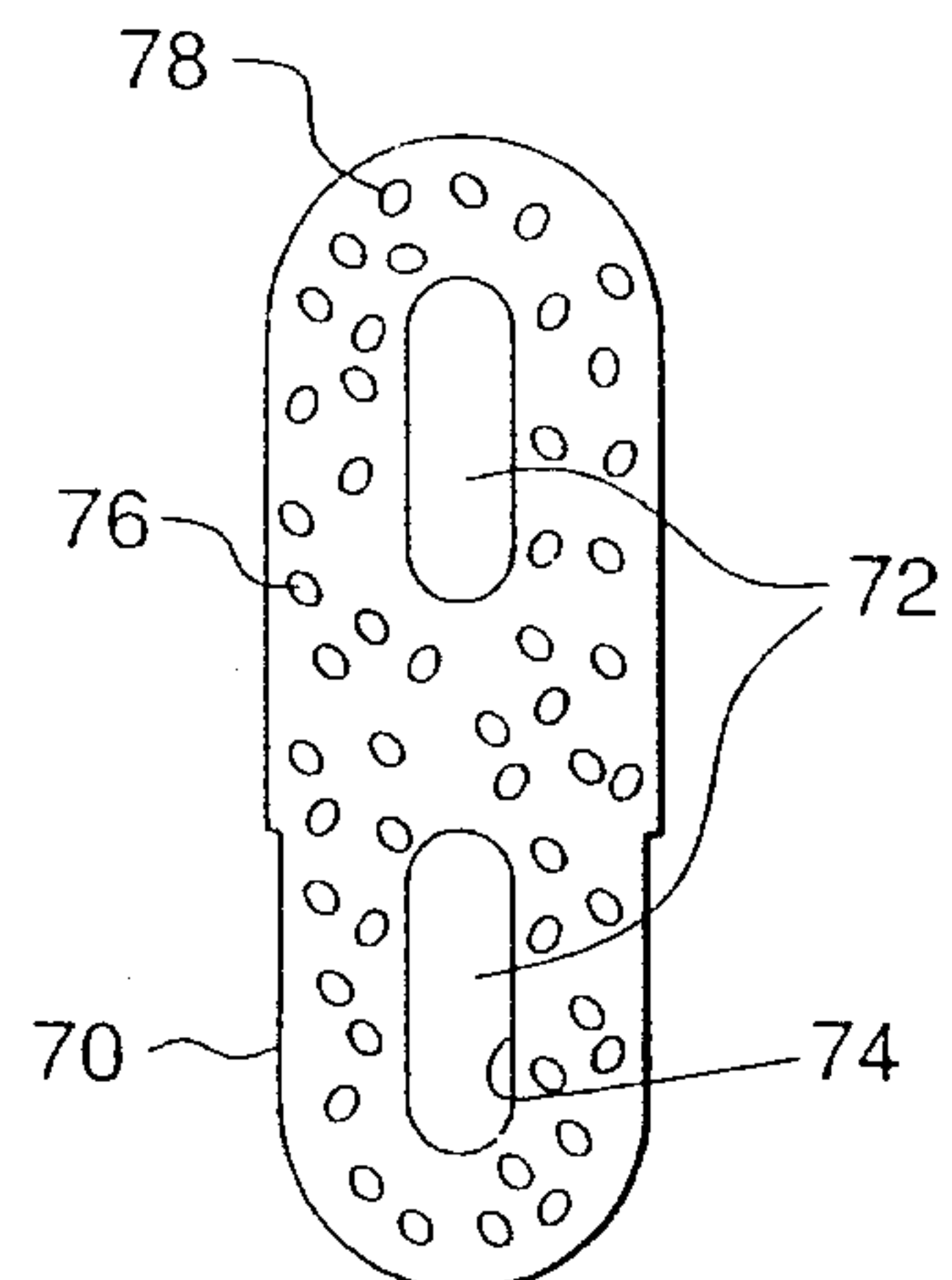

FIG. 4

