

**(12) INNOVATION PATENT**  
**(19) AUSTRALIAN PATENT OFFICE**

(11) Application No. **AU 2016100741 A4**

(54) Title  
**A dimmable LED lighting device**

(51) International Patent Classification(s)  
**F21V 21/088** (2006.01)                      **F21V 21/14** (2006.01)

(21) Application No: **2016100741**                      (22) Date of Filing: **2016.05.23**

(30) Priority Data

(31) Number	(32) Date	(33) Country
<b>2016203154896</b>	<b>2016.04.15</b>	<b>CN</b>

(45) Publication Date: **2016.07.07**

(45) Publication Journal Date: **2016.07.07**

(45) Granted Journal Date: **2016.07.07**

(71) Applicant(s)  
**Quanzhou City Laite Lighting Co., Ltd.**

(72) Inventor(s)  
**Sun, XuDong**

(74) Agent / Attorney  
**Leoniepat, 15600 W. 99th St., Lenexa, VIC, 6621**

2016100741 23 May 2016

This utility model discloses a dimmable LED lighting device, including lamp post. Motion sleeve No.1 is set up on the lamp post mentioned. Connecting strip is set up at both ends of motion sleeve No.1 mentioned. Support bar is set up on the top of both ends of motion sleeve No.1. Sliding wheel is set up on the top of the support bar mentioned . The sliding wheel and the support bar mentioned have flexible connection. Support ring is set up at the end of the connecting strip mentioned away from the lamp post mentioned. The top of the support ring has a plane. Rotating seat is set up on the plane mentioned. LED lamp body is arranged rotationally on the rotating seat mentioned. Axis of rotation is arranged between LED lamp body and rotating seat mentioned. Clamp spring is arranged between the axis of rotation and the LED lamp body mentioned. Ring part is set up in the rear part of the LED lamp body mentioned.1

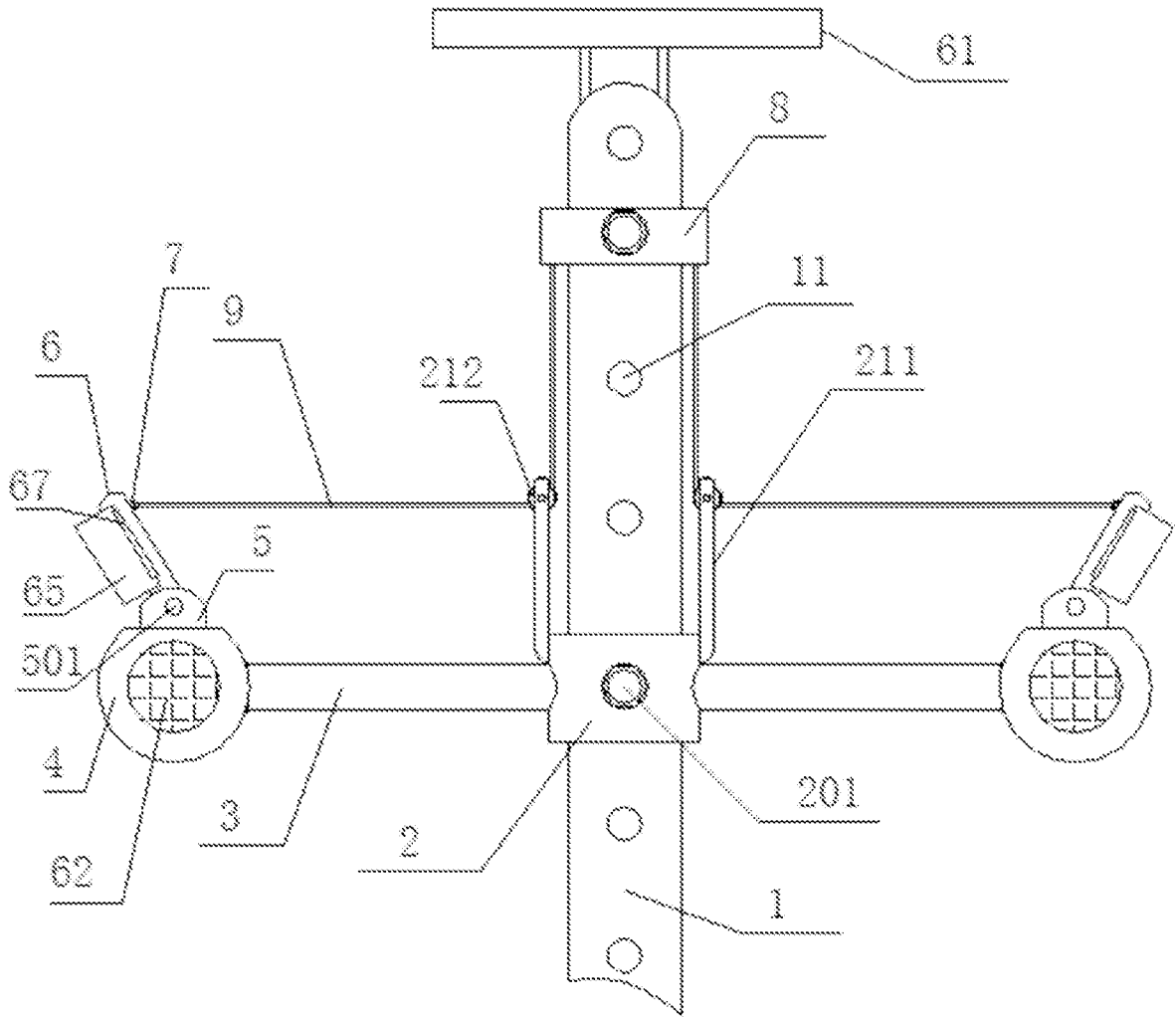

Fig.1

## D e s c r i p t i o n s

---

A dimmable LED lighting device

### **Technical field**

This utility model involves a dimmable LED lighting device.

### **Background technology**

Auxiliary lighting device is generally set up in large intersections, which has highlight illumination and provides strong illumination for vehicles, thus reducing the occurrence of accidents. Most lighting devices in existing technologies are supplied with multiple LED lamps set up separately. It is necessary to adjust lighting direction one by one. Therefore, their debugging is complicated. After the completion of debugging, they should be located with screws. After a long time, they will loosen. Therefore, it is necessary to debug and fasten them again, which is troublesome.

### **Invention content**

The technical problem to be solved by this utility model is to provide a dimmable LED lighting device. The clamp spring arranged between the axis of rotation and LED lamp body provides LED lamp body with a force of rotation towards outside. Then, a binding force towards inside is produced with cord pull. Cord pull allows LED lamp body to rotate to the required angle around the rotating seat. The binding force produced with cord pull can effectively avoid angle rotation of LED lamp body in the use process. Rotatable spotlight panel is used for refraction and gathering of light emitted by LED lamp body and the increase of illumination intensity. When it is unnecessary to use spotlight panel, just invert it for placement. Meanwhile, this device can complete angle fixation

of LED lamp body by moving the position of motion sleeve No.2 on the lamp post. The fixation through bolt makes it easy to adjust and operate. Solar panel can transform solar energy into electric energy which will be stored in battery pack, thus providing power for LED lamp body and greatly saving energy. This device has simple structure and low costs and is easy to use and suitable for promotion for use.

To solve problems above, this utility model adopts the following technical scheme:

A dimmable LED lighting device includes lamp post. Motion sleeve No.1 is set up on the lamp post mentioned. Connecting strip is set up at both ends of motion sleeve No.1 mentioned. Support bar is set up on the top of both ends of motion sleeve No.1. Sliding wheel is set up on the top of the support bar mentioned . The sliding wheel and the support bar mentioned have flexible connection. Support ring is set up at the end of the connecting strip mentioned away from the lamp post mentioned. The top of the support ring has a plane. Rotating seat is set up on the plane mentioned. LED lamp body is arranged rotationally on the rotating seat mentioned. Axis of rotation is arranged between LED lamp body and rotating seat mentioned. Clamp spring is arranged between the axis of rotation and the LED lamp body mentioned. Ring part is set up in the rear part of the LED lamp body mentioned. Spotlight panel is set up on the shell of the LED lamp body mentioned. The spotlight panel is connected to the shell of the LED lamp body mentioned rotationally via hinge. Motion sleeve No.2 is set up on the lamp post mentioned. Cord pull

is set up at the bottom on both sides of motion sleeve No.2. The cord pull passes through the sliding wheel mentioned and is permanently connected to the ring part mentioned. Connecting holes used for fixing motion sleeves No.1 and No.2 mentioned are set up evenly on the lamp post from top to bottom. Motion sleeves No.1 and No.2 mentioned fit with connecting holes mentioned through bolt and are fixed on the lamp post mentioned. Solar panel is set up at the top end of the lamp post mentioned. Battery pack is set up in the support ring mentioned. The solar panel, battery pack and LED lamp body are electrically connected successively. Inverter is connected between the solar panel and the battery pack mentioned.

Preferably, sliding hole having sliding fit with the lamp post mentioned is set up on motion sleeves No.1 and No.2 mentioned. Motion sleeve No.1 has a higher height than motion sleeve No.2.

Preferably, the connecting strip and the motion sleeve No.1 mentioned are permanently connected through welding. The support ring and the motion sleeve No.1 are permanently connected through welding. The support bar and the motion sleeve No.1 are permanently connected through stop pin.

Preferably, the top of the lamp post mentioned has spherical transition. The top of the lamp post mentioned is sealed.

Preferably, there are two LED lamp bodies mentioned. The LED lamp body mentioned is high-power LED illuminator.

Beneficial effect of this utility model: the clamp spring arranged between the axis of rotation and LED lamp body provides LED lamp body with a force

of rotation towards outside. Then, a binding force towards inside is produced with cord pull. Cord pull allows LED lamp body to rotate to the required angle around the rotating seat. The binding force produced with cord pull can effectively avoid angle rotation of LED lamp body in the use process. Rotatable spotlight panel is used for refraction and gathering of light emitted by LED lamp body and the increase of illumination intensity. When it is unnecessary to use spotlight panel, just invert it for placement. Meanwhile, this device can complete angle fixation of LED lamp body by moving the position of motion sleeve No.2 on the lamp post. The fixation through bolt makes it easy to adjust and operate. Solar panel can transform solar energy into electric energy which will be stored in battery pack, thus providing power for LED lamp body and greatly saving energy. This device has simple structure and low costs and is easy to use and suitable for promotion for use.

### **Descriptions of attached figure**

To illustrate implementation example of this utility model or technical proposal in existing technologies more clearly, attached figures to be used in implementation example or descriptions of existing technologies are briefly introduced below. Obviously, attached figures described below are only some implementation examples of this utility model. Common technical personnel in this field can obtain other attached figures according to these attached figures without creative work.

Fig.1 is the structural schematic diagram of this utility model.

### **Detailed implementation way**

Preferable implementation example of this utility model is illustrated below in combination with attached figures so that advantages and features of this utility model can be understood by technical personnel in this field more easily and the protection scope of this utility model can be defined more clearly.

A dimmable LED lighting device shown in fig.1 includes lamp post 1. Motion sleeve No.1 2 is set up on the lamp post 1 mentioned. Connecting strip 3 is set up at both ends of motion sleeve No.1 2 mentioned. Support bar 211 is set up on the top of both ends of motion sleeve No.1 2. Sliding wheel 212 is set up on the top of the support bar 211 mentioned . The sliding wheel 212 and the support bar 211 mentioned have flexible connection. Support ring 4 is set up at the end of the connecting strip 3 mentioned away from the lamp post 1 mentioned. The top of the support ring 4 has a plane. Rotating seat 5 is set up on the plane mentioned. LED lamp body 6 is arranged rotationally on the rotating seat 5 mentioned. Axis of rotation 501 is arranged between LED lamp body 6 and rotating seat 5 mentioned. Clamp spring (not shown in the figure) is arranged between the axis of rotation 501 and the LED lamp body 6 mentioned. Ring part 7 is set up in the rear part of the LED lamp body 6 mentioned. Spotlight panel 65 is set up on the shell of the LED lamp body 6 mentioned. The spotlight panel 65 is connected to the shell of the LED lamp body 6 mentioned rotationally via hinge 67. Motion sleeve No.2 8 is set up on the lamp post 1 mentioned. Cord pull 9 is set up at the bottom on both sides of motion sleeve No.2 8. The cord pull 9 passes through the sliding wheel 212

mentioned and is permanently connected to the ring part 7 mentioned. Connecting holes 11 used for fixing motion sleeves No.1 2 and No.2 8 mentioned are set up evenly on the lamp post 1 from top to bottom. Motion sleeves No.1 2 and No.2 8 mentioned fit with connecting holes 11 mentioned through bolt 201 and are fixed on the lamp post 1 mentioned. Solar panel 61 is set up at the top end of the lamp post 1 mentioned. Battery pack 62 is set up in the support ring 4 mentioned. The solar panel 61, battery pack 62 and LED lamp body 6 are electrically connected successively. Inverter is connected between the solar panel 61 and the battery pack 62 mentioned.

A better implementation example in this utility model: sliding hole (not shown in the figure) having sliding fit with the lamp post mentioned is set up on motion sleeves No.1 2 and No.2 8 mentioned. Motion sleeve No.1 2 has a higher height than motion sleeve No.2 8.

A better implementation example in this utility model: the connecting strip 3 and the motion sleeve No.1 2 mentioned are permanently connected through welding. The support ring 4 and the motion sleeve No.1 2 are permanently connected through welding. The support bar 211 and the motion sleeve No.1 2 are permanently connected through stop pin (not shown in the figure).

A better implementation example in this utility model: the top of the lamp post 1 mentioned has spherical transition. The top of the lamp post 1 mentioned is sealed.

A better implementation example in this utility model: there are two LED

---

lamp bodies 6 mentioned. The LED lamp body 6 mentioned is high-power LED illuminator.

Beneficial effect of this utility model: the clamp spring arranged between the axis of rotation and LED lamp body provides LED lamp body with a force of rotation towards outside. Then, a binding force towards inside is produced with cord pull. Cord pull allows LED lamp body to rotate to the required angle around the rotating seat. The binding force produced with cord pull can effectively avoid angle rotation of LED lamp body in the use process. Rotatable spotlight panel is used for refraction and gathering of light emitted by LED lamp body and the increase of illumination intensity. When it is unnecessary to use spotlight panel, just invert it for placement. Meanwhile, this device can complete angle fixation of LED lamp body by moving the position of motion sleeve No.2 on the lamp post. The fixation through bolt makes it easy to adjust and operate. Solar panel can transform solar energy into electric energy which will be stored in battery pack, thus providing power for LED lamp body and greatly saving energy. This device has simple structure and low costs and is easy to use and suitable for promotion for use.

The above shows and describes basic principle, main features and advantages of this utility model. Technical personnel in this industry should know that this utility model is not limited by the implementation example above. The implementation example and descriptions above only describe principles of this utility model. This utility model will have various changes and improvements without violating the spirit and scope of this utility model. Such

---

changes and improvements will fall into the scope of this utility model requiring protection. The scope of protection required by this utility model is defined by the claim attached and its equivalent.

2016100741 05 Jun 2016

1. A dimmable LED lighting device characterized by the following: it includes lamp post. Motion sleeve No.1 is set up on the lamp post mentioned. Connecting strip is set up at both ends of motion sleeve No.1 mentioned. Support bar is set up on the top of both ends of motion sleeve No.1. Sliding wheel is set up on the top of the support bar mentioned . The sliding wheel and the support bar mentioned have flexible connection. Support ring is set up at the end of the connecting strip mentioned away from the lamp post mentioned. The top of the support ring has a plane. Rotating seat is set up on the plane mentioned. LED lamp body is arranged rotationally on the rotating seat mentioned. Axis of rotation is arranged between LED lamp body and rotating seat mentioned. Clamp spring is arranged between the axis of rotation and the LED lamp body mentioned. Ring part is set up in the rear part of the LED lamp body mentioned. Spotlight panel is set up on the shell of the LED lamp body mentioned. The spotlight panel is connected to the shell of the LED lamp body mentioned rotationally via hinge. Motion sleeve No.2 is set up on the lamp post mentioned. Cord pull is set up at the bottom on both sides of motion sleeve No.2. The cord pull passes through the sliding wheel mentioned and is permanently connected to the ring part mentioned. Connecting holes used for fixing motion sleeves No.1 and No.2 mentioned are set up evenly on the lamp post from top to bottom. Motion sleeves No.1 and No.2 mentioned fit with connecting holes mentioned through bolt and are fixed on the lamp post mentioned. Solar panel is set up at the top end of the lamp post mentioned. Battery pack is

- set up in the support ring mentioned. The solar panel, battery pack and LED lamp body are electrically connected successively. Inverter is connected between the solar panel and the battery pack mentioned.
2. The dimmable LED lighting device mentioned according to claim 1 is characterized by the following: sliding hole having sliding fit with the lamp post mentioned is set up on motion sleeves No.1 and No.2 mentioned. Motion sleeve No.1 has a higher height than motion sleeve No.2.
  3. The dimmable LED lighting device mentioned according to claim 1 is characterized by the following: the connecting strip and the motion sleeve No.1 mentioned are permanently connected through welding. The support ring and the motion sleeve No.1 are permanently connected through welding. The support bar and the motion sleeve No.1 are permanently connected through stop pin.
  4. The dimmable LED lighting device mentioned according to claim 1 is characterized by the following: the top of the lamp post mentioned has spherical transition. The top of the lamp post mentioned is sealed.
  5. The dimmable LED lighting device mentioned according to claim 1 is characterized by the following: there are two LED lamp bodies mentioned. The LED lamp body mentioned is high-power LED illuminator.

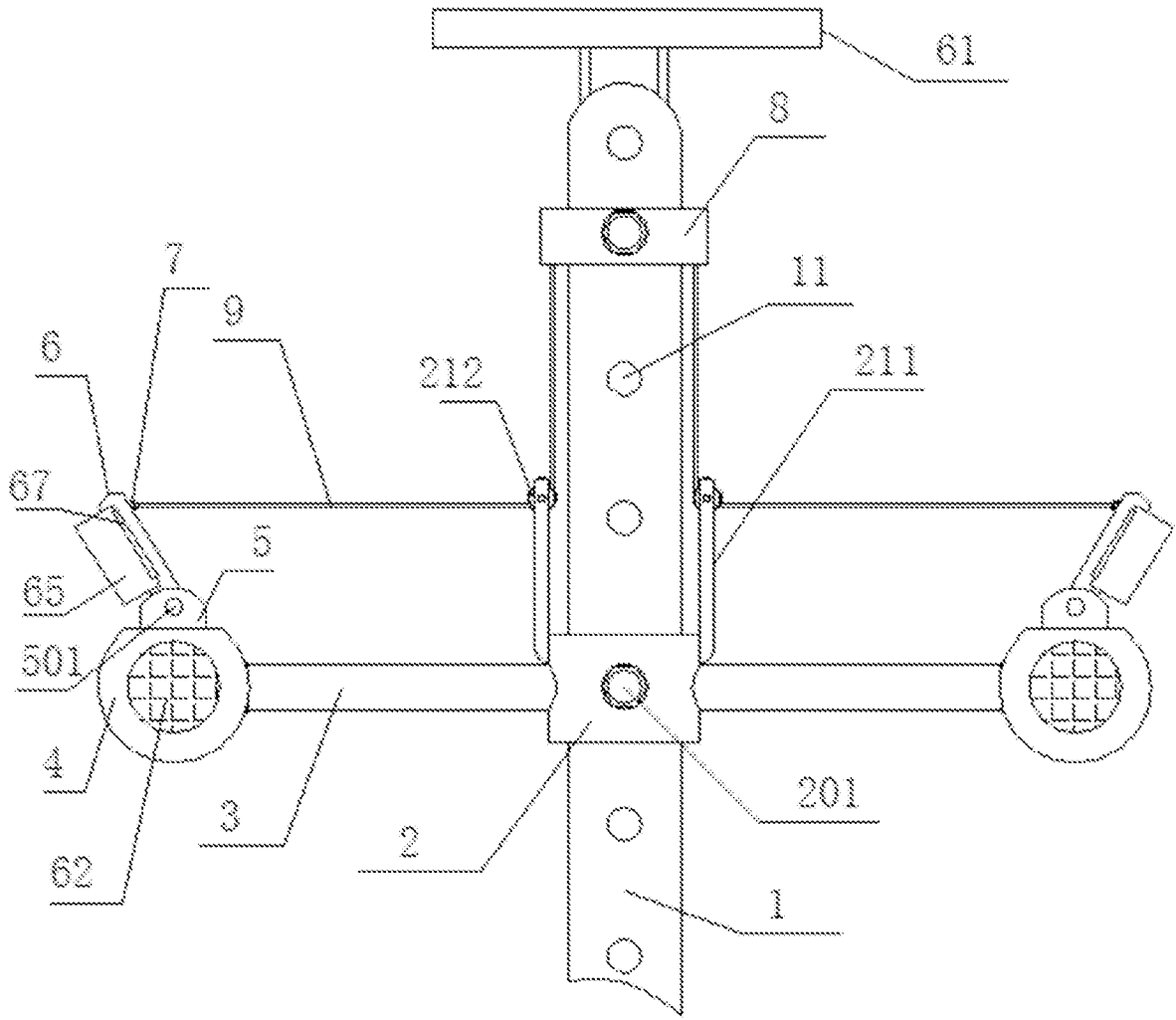

Fig.1