



- (51) International Patent Classification:
E21B 43/04 (2006.01)
- (21) International Application Number:
PCT/US2013/068424
- (22) International Filing Date:
5 November 2013 (05.11.2013)
- (25) Filing Language: English
- (26) Publication Language: English
- (30) Priority Data:
13/670,125 6 November 2012 (06.11.2012) US
- (71) Applicant: **WEATHERFORD/LAMB, INC.** [US/US];
2000 St. James Place, Houston, TX 77056 (US).
- (72) Inventors: **BROUSSARD, John**; 4106 Quiet Glade Ct.,
Kingwood, TX 77345 (US). **VAN PETEGEM, Ronald**;
11568 Grand Pine Dr., Montgomery, TX 77356 (US).
HALL, Christopher, A.; 16331 Cumberland Trail,
Cypress, TX 77433 (US).
- (74) Agent: **MCDERMOTT, Sean, P.**; Wong Cabello Lutsch
Rutherford & Bruculeri LLP, 20333 Tomball Parkway,
6th Floor, Houston, TX 77070 (US).
- (81) Designated States (*unless otherwise indicated, for every
kind of national protection available*): AE, AG, AL, AM,
AO, AT, AU, AZ, BA, BB, BG, BH, BN, BR, BW, BY,
BZ, CA, CH, CL, CN, CO, CR, CU, CZ, DE, DK, DM,

DO, DZ, EC, EE, EG, ES, FI, GB, GD, GE, GH, GM, GT,
HN, HR, HU, ID, IL, IN, IR, IS, JP, KE, KG, KN, KP, KR,
KZ, LA, LC, LK, LR, LS, LT, LU, LY, MA, MD, ME,
MG, MK, MN, MW, MX, MY, MZ, NA, NG, NI, NO, NZ,
OM, PA, PE, PG, PH, PL, PT, QA, RO, RS, RU, RW, SA,
SC, SD, SE, SG, SK, SL, SM, ST, SV, SY, TH, TJ, TM,
TN, TR, TT, TZ, UA, UG, US, UZ, VC, VN, ZA, ZM,
ZW.

- (84) Designated States (*unless otherwise indicated, for every
kind of regional protection available*): ARIPO (BW, GH,
GM, KE, LR, LS, MW, MZ, NA, RW, SD, SL, SZ, TZ,
UG, ZM, ZW), Eurasian (AM, AZ, BY, KG, KZ, RU, TJ,
TM), European (AL, AT, BE, BG, CH, CY, CZ, DE, DK,
EE, ES, FI, FR, GB, GR, HR, HU, IE, IS, IT, LT, LU, LV,
MC, MK, MT, NL, NO, PL, PT, RO, RS, SE, SI, SK, SM,
TR), OAPI (BF, BJ, CF, CG, CI, CM, GA, GN, GQ, GW,
KM, ML, MR, NE, SN, TD, TG).

Declarations under Rule 4.17:

- *as to applicant's entitlement to apply for and be granted a patent (Rule 4.17(ii))*
- *as to the applicant's entitlement to claim the priority of the earlier application (Rule 4.17(iii))*

Published:

- *without international search report and to be republished upon receipt of that report (Rule 48.2(g))*



WO 2014/074485 A2

(54) Title: MULTI-ZONE SCREENED FRACTURING SYSTEM

(57) Abstract: A multi-zone formation treatment assembly has sections disposed on a tubular structure in a borehole. An isolation element disposed on the tubular structure that isolates a borehole annulus around the section from the other sections, and a flow valve disposed on the tubular structure is selectively operable between opened and closed conditions permitting and preventing fluid communication between the through-bore and the borehole annulus. A screen disposed on the tubular structure communicates with the borehole annulus, and a closure disposed on the tubular structure at least prevents fluid communication from the through-bore to the screen. A workstring of the assembly can be manipulated in the tubular structure relative to each section in the same trip to: open the flow valve, position in the through-bore relative to the open flow valve, deliver the treatment from an outlet to the section through the open flow valve, and close the flow valve.

Multi-Zone Screened Fracturing System

CROSS-REFERENCE TO RELATED APPLICATIONS

[0001] This is a PCT filing of U.S. Appl. 13/670,125, filed 06-NOV-2012, which is a continuation-in-part of U.S. Appl. 13/545,908, filed 10-JUL-2012, which claims priority to U.S. Provisional Appl. 61/506,897, filed 12-JUL-2011, which are both incorporated herein by reference and to which priority is claimed.

BACKGROUND

[0002] Wells in some reservoirs need to be hydraulically fractured to stimulate the production rates and make the wells commercially viable. For this process, the wells are fractured with a proppant (e.g., sand or the like) to treat the formation and improve production. In many cases, multiple fracs are performed in a single wellbore to treat various zones of interest in the formation. In some of these reservoirs, the wells needing fracing are in deepwater areas where production facilities cannot handle any produced solids, e.g., formation sand or fracturing proppant.

[0003] Currently, completions for such reservoirs use single-trip, multi-zone systems that allow operators to frac multiple zones in a single trip in the wellbore, and some single-trip, multi-zone frac systems use a wellscreen to prevent proppant flowback during operations. Unfortunately, the current single-trip, multi-zone systems that have a wellscreen require a service crossover tool be used for operation. The crossover tool in these systems crosses over the fluid flow path from a workstring to the annulus outside the wellscreen and *vice versa*.

[0004] Using these system and crossover tools has a number of disadvantages. For example, the systems and crossover tools are very complicated and difficult to install and operate. They also offer

tremendous risks because the chances of sticking in the well are quite high.

[0005] Although few fracing operations using single-trip, multi-zone frac systems have been done to date, there is a lot of interest in these systems due to the potential savings in deepwater operations. What is needed then is a single-trip, multi-zone frac system that can overcome, or at least reduce the effects of, one or more of the problems set forth above.

SUMMARY OF THE DISCLOSURE

[0006] A multi-zone formation treatment assembly for a borehole has a tubular structure disposed in the borehole and defining a through-bore. The assembly can be used for formation treatments, such as frac operations, frac pack operation, gravel pack operations, or other operations. Sections are disposed on the tubular structure, and each section has an isolation element, a flow valve, a screen, and a closure.

[0007] The isolation element, which can be a swellable packer, a hydraulically-set packer, or a mechanically-set packer, isolates the borehole annulus around the section from the other sections along the borehole. If desired, a flow tube can be disposed in the borehole annulus and can communicate through the isolation elements between one or more of the sections. The flow tube can be used for dehydration of fluid in the borehole annulus of the sections during a frac pack operation, for example.

[0008] The flow valve is selectively operable between opened and closed conditions to permit or prevent fluid communication between the through-bore and the borehole annulus. When opened, the flow valve is used primarily to deliver the treatment into the borehole annulus for a section through a first flow path.

[0009] The screen disposed on the tubular structure communicates with the borehole annulus and can communicate with the assembly's through-bore through a second flow path. The closure at least prevents fluid communication from the through-bore of the tubular structure to the

screen. In one condition, for example, the closure prevents fluid communication from the through-bore to the screen. This condition is used when performing the formation treatment. However, in another condition, the closure allows fluid communication from the screen to the through-bore. This condition is used after the treatment operations so production fluid can communicate into the through-bore from the screen.

[0010] In one arrangement, the flow valve is a sliding sleeve having a housing and a closure element, such as an inner sleeve or insert, movable therein relative to a flow port. The inner sleeve can be moved between the closed and opened conditions preventing or permitting fluid communication through the flow port.

[0011] To move the inner sleeve in some embodiments, for example, a plug or ball can be deployed in the tubular structure to engage a seat disposed in the inner sleeve. Then, fluid pressure applied against the seated plug then moves the inner sleeve open to expose the flow port.

[0012] In other embodiments to move the inner sleeve, plugs or balls may not be used. Instead, the flow valve's inner sleeve can be moved open and closed by a shifting tool in addition to or as an alternative to the ball and seat arrangement. In particular, a workstring can be run in the through-bore of the tubular structure, and an actuating tool on the workstring can be used to open and close the flow valve of each section.

[0013] In one arrangement, the closure can also have an inner sleeve that can at least be opened by the shifting tool of the workstring. Opening of the closure is performed after formation treatment is complete so the assembly can be used for production operations. Thus, the closure as an inner sleeve can selectively prevent and permit fluid communication via the second flow path from the screen to the assembly's through-bore.

[0014] To prevent fluid loss through the screen during treatment, however, the closure preferably has a one-way or check valve placed in fluid communication between the screen and the through-bore. The check valve at least prevents fluid communication from the tubular structure's through-bore to the screen. Thus, the check valve can exclusively prevent

fluid communication via the second flow path the assembly's through-bore to the screen.

[0015] In one arrangement, the screen has first and second screen sections disposed on the tubular structure on both sides of a flow port in the tubular structure. The two screen sections can communicate screened fluid from the borehole annulus to the flow port. In this arrangement, the closure is disposed on the tubular structure in fluid communication between the first and second screen sections and the flow port.

[0016] In particular, an inner sleeve can be selectively opened and closed relative to a flow port in the tubular structure that communicates with the screen sections. Interposed between the flow port and the screen sections, however, are check valve having check balls and flow passages. The check balls can move to permit or block fluid communication through the flow passages. In one condition, for example, the check balls permit fluid communication from the screen sections to the flow port through the flow passages, while in another condition, the check balls prevent fluid communication from the flow port to the screen sections through the flow passages.

[0017] In a multi-zone formation treatment method for a borehole, an assembly disposes in the borehole, and an annulus of the borehole around the assembly is isolated into a plurality of isolated zones to treat the isolated zones. To isolate the annulus, for example, the method can involve engaging isolation elements on the assembly against the borehole.

[0018] A workstring is disposed in the through-bore of the assembly. Treating each of the isolated zones with a treatment fluid involves selectively opening a first port in the assembly at a given isolated zone with the workstring. Then, the treatment fluid flows down the workstring to the isolated zone through the opened first port, while selectively preventing fluid communication from the borehole annulus to the assembly's through-bore through a screen on the assembly at the isolated zone.

[0019] After treatment at the isolated zone, the first port is selectively closed with the workstring. When all treatment operations of the various

zones are complete, the assembly is set up for production. The workstring in the same trip then opens the closures, allowing fluid in the borehole annulus to flow through the screen and into the assembly's through-bore. Fluid communication from the annulus of the isolated zones can then be screened into the through-bore of the assembly with the screens on the assembly. However, check valves on the assembly prevent fluid communication from the through-bore to the annulus of the isolated zones through the screens.

[0020] The foregoing summary is not intended to summarize each potential embodiment or every aspect of the present disclosure.

BRIEF DESCRIPTION OF THE DRAWINGS

[0021] Fig. 1 illustrates a multi-zone screened frac system according to the present disclosure disposed in a cased borehole and having sections with frac valves and flow devices.

[0022] Fig. 2A illustrates the multi-zone screened frac system of Fig. 1 having a dehydration tube.

[0023] Fig. 2B illustrates the multi-zone screened frac system of Fig. 1 having an expandable liner.

[0024] Fig. 3 illustrates a multi-zone screened frac system according to the present disclosure disposed in an open borehole and having sections with frac valves and flow devices.

[0025] Fig. 4 illustrates a multi-zone screened frac system according to the present disclosure disposed in an uncased borehole and using a workstring in conjunction with frac valves and flow devices.

[0026] Fig. 5 illustrates the multi-zone screened frac system of Fig. 4 having flow tubes.

[0027] Fig. 6A illustrates a partial cross-sectional view of a flow device for the disclosed multi-zone screened frac systems.

[0028] Fig. 6B illustrates a detailed view of a check valve device for the flow device of Fig. 6A.

[0029] Fig. 6C illustrates an isolated, partial cross-sectional view of the inflow flow control device of Fig. 6A.

[0030] Figs. 7A-7B illustrate partial cross-sectional views of a multi-select sliding sleeve in closed and opened states for the flow valves in the disclosed multi-zone screen frac systems.

[0031] Figs. 8A-8B illustrate shifting tools for use on a workstring for the disclosed system of Figs. 4-5.

[0032] Figs. 9A-9D illustrate another multi-zone screened frac system according to the present disclosure disposed in a uncased borehole and using a workstring in conjunction with frac valves and flow devices.

[0033] Figs. 10A-10B illustrate partial cross-sectional views of another frac valve for the disclosed systems in closed and open positions.

[0034] Fig. 11 illustrates a partial cross-sectional view of another flow device for the disclosed systems.

DETAILED DESCRIPTION

[0035] Various embodiments of a multi-zone screened frac system are disclosed. The system does not require a crossover tool as required in the prior art. In some implementations, certain embodiments of the systems do not even require a complete service tool. To perform a frac operation on multiple zones in a cased or open borehole, the system combines: (1) wellscreens with integrated one-way or check valves, (2) frac valves, and (3) optional shunt tubes for slurry dehydration. The system can also include fiber optic technology.

[0036] In a first embodiment according to the present disclosure, Figure 1 illustrates a multi-zone screened frac system 10 disposed in a cased borehole and having sections 28 with frac valves 30 and flow devices 40, which include wellscreens 46 and closure element 48. The system 10 includes an upper completion or workstring 14 disposed in casing 12. This string 14 is engaged in an uphole end 24 of a production string 22 of a frac assembly 20 and can engage the casing 12 with an optional packer 16.

[0037] Internally, the production string 22 of the frac assembly 20 has a through-bore 25 communicating along the length of the string 22 and communicating with the completion string 14. Externally, the frac assembly 20 has isolation devices 18, such as but not limited to a hydraulic, a mechanical, or a swellable packer, to seal the production string 22 in the casing 12. One of the packers 18 is disposed at the string 22's uphole end 24, while other packers 18 are disposed along the length of the production string 22. Separated by the packers 18, the frac assembly 20 has various sections 28 disposed at various intervals or zones of interest in the surrounding formation. At its downhole end 26, the frac assembly 20 has a bottom seat 50 for engaging a setting ball 54 during frac operations.

[0038] Each section 28 has a selective frac valve 30 and a flow device 40. Each of the selective frac valves 30 and flow devices 40 in a given section 28 is separated from other sections 28 by the packers 18, which isolate the borehole annulus 15 for the respective sections 28. As shown, the selective frac valves 30 are disposed uphole of the flow devices 40 in the various sections 28. As an alternative, the selective frac valves 30 can be disposed downhole of the flow devices 40 in the section 28.

[0039] The selective frac valves 30 have one or more ports 32 that can be selectively opened and closed during operation with a closure element 34 (e.g., inner sleeve). In this arrangement and as discussed in more detail below, for example, each of the selective frac valves 30 can be opened to communicate their ports 32 with the surrounding annulus 15 by using frac plugs or balls 36 deployed downhole during frac operations. As treatment is performed in the well, these dropped plugs or balls 36 selectively open the frac valves 30 and isolate lower sections 28 so the selective frac valves 30 can successively divert frac treatment to adjacent zones of interest up the frac assembly 20.

[0040] The flow device 40 for each section 28 is disposed adjacent or near perforations 13 in the casing 12. In this and other assemblies disclosed herein, the flow devices 40 use wellscreens 46 with integrated

closure elements 48 (e.g., one-way or check valves) to control the flow of fluid through the flow devices 40. In particular, each flow device 40 exclusively screens fluid communication through a first flow path (*i.e.*, flow from the borehole annulus 15 to the through-bore 25 of the assembly 20 through the flow device 40). At the same time, the flow device 40 exclusively prevents fluid communication from the through-bore 25 of the assembly 20 to the borehole annulus 15 along this first flow path. Thus, the wellscreen 46 screens fluid flow along the first flow path from the borehole annulus 15 to the through-bore 25. However, the flow device 40 does not permit fluid flow in the opposite direction along this same flow path, and exclusively prevents flow from the through-bore 25 to the borehole annulus 15 through the wellscreen 46.

[0041] In particular, the flow devices 40 can each include a wellscreen 46 and a closure device 48, which can be an inflow control device such as a FloReg™ Deploy-Assist (DA) Device available from Weatherford International. Preferably, the closure element 48 lacks nozzles and is used in the system 10 primarily as a check valve, but nozzles can be used in other arrangements to create a pressure differential in produced fluid. Further details of a suitable flow device 40 having a wellscreen 46 and a closure element 48, which can be an inflow control device such as the FloReg™ Deploy-Assist (DA) Device, are provided below in Figures 6A-6C. Moreover, details of a suitable inflow control device for the closure element 48 used with a wellscreen 46 are also disclosed in U.S. Pat. Nos. 6,371,210 and 7,828,067, which are incorporated herein by reference in their entireties.

In this and other assemblies disclosed herein, each selective frac valve 30 selectively permits and prevents fluid communication through a second flow path (*i.e.*, between the through-bore 25 of the assembly 20 and the borehole annulus 15). In particular, the selective frac valves 30 can be sliding sleeves, such as a ZoneSelect™ MultiShift frac sliding sleeve available from Weatherford International. The selective frac valve 30 is designed to open when a ball 36 lands on a landing seat (not labeled)

disposed in the selective frac valve 30 and tubing pressure is then applied to shear the selective frac valve 30 open to expose the through-bore 25 to the surrounding annulus 15. Again, a ball 36 for a section 28 is dropped from the surface once the appropriate amount of proppant is pumped into the previously treated section 28. Further details of a suitable multi-shift sliding sleeve, such as the ZoneSelect™ MultiShift frac sliding sleeve, are provided below in Figures 7A-7B.

[0042] In this and other assemblies 10 disclosed herein, a fracing operation uses the series of packers 18 and selective frac valves 30 to sequentially isolate and treat the different zones or sections 28 of the downhole formation. Initially, the assembly 20 having the packers 18, selective frac valves 30, and flow devices 40 is run downhole and set up using known techniques. Eventually, a bottom plug or ball 54 is pumped downhole to close off the flow path through the assembly's bottom end 50.

[0043] Next, operators set the packers 18 to create the multiple isolated sections 28 down the borehole annulus 15. How the packers 18 are set depends on the type of packers 18 used. For example, hydraulic pressure pumped down the assembly's through-bore 25 can be used to set the packers 18. The closed bottom end 50, the closed frac valves 30, and the integrated closure elements 48 prevent fluid pressure in the assembly 20 from escaping to the annulus 15 during the setting procedures. Use of different types of packers 18 would require other known procedures.

[0044] Once the packers 18 are set, operators apply a frac treatment successively to each of the isolated sections 28 by selectively opening the selective frac valves 30 and allowing the treatment fluid to interact with the adjacent zones of the formation through the opened ports 32. To open each frac valve 30, for example, operators drop specifically sized plugs or balls 36 into the assembly 20 and land them on corresponding seats (not shown) on the designated frac valves 30. Typically, the balls 36 increase in size up the borehole so that a smaller ball 36 can pass through all of the seats (not shown) on the uphole frac valves 30 before engaging its designated seat further downhole. For example, a range of plugs or balls

36 may allow fracturing up to 13, 19, and 21 sections in the borehole when 3-1/2 in., 4-1/2 in., and 5-1/2 in. frac valves 30 are used, respectively. An additional section can be added by using a toe sleeve (not shown).

[0045] Once a dropped ball 36 is seated, the ball 36 closes off the lower section 28 just treated, and built up pressure on the seated ball 36 forces the frac valve 30 open so frac fluid can interact with the adjacent zone of the formation through the open flow ports 32. Operators repeat this process up the assembly 20 to treat all of the sections 28 by successively dropping bigger balls 36 against bigger seats (not shown) in the frac valves 30. Once the frac treatment is complete, flow in the assembly 20 can float all the balls 36 to the surface, or operators can mill out the balls 36 and ball seats (not shown) from the frac valves 30. Finally, after fracing, the system 10 may need a clean-out trip in which a fluid wash is pumped down the assembly 10 to clear it of excess or residual proppant and frac fluid.

[0046] The multi-zone frac system 10 of Figure 1 can achieve higher flow rates and can improve reservoir performance while: only requiring one trip upper and lower completions, using standard packers, not requiring a crossover tool, and offering less risk. The system 10 can also have any suitable length and spacing between sections 28. A wet-connector is not required for using fiber optics, and the system 10 allows for monitoring while fracing using a fiber optic based sensor system (not shown).

[0047] In a second embodiment according to the present disclosure, the multi-zone screened frac system 10 of Figure 2A is similar to that of Figure 1 so that similar components are shown with the same reference numerals. In contrast to the previous arrangement, however, this system 10 has a dehydration tube (*i.e.*, slurry or flow tube) 60 disposed along the assembly 20 running from the optional packer 16 at the uphole end 24 to the lower most packer 18 near the downhole end 26. Although the dehydration tube 60 may present a barrier issue, any potential problems can be mitigated by running a production packer (not shown) uphole in the casing 12.

[0048] The dehydration tube 60 communicates with the borehole annulus 15 of each of the sections 28 using flow ports (not shown) or the like. Additionally, the tube 60 passes through the packers 18 isolating the sections 28. Use of the tube 60 is beneficial when frac pack operations are performed, which involve fracing a zone of interest and then gravel packing the borehole annulus 15 around the wellscreen 46. In this way, the tube 60 in the system 10 allows the system 10 to dehydrate the annular gravel pack when performed.

[0049] After fracing operations, the system 10 in Figure 2A may need a clean-out trip and may require 3-4 MM in lower tertiary. The multi-zone frac system 10 of Figure 2A can provide higher rates and improve reservoir performance while not requiring a crossover tool and offering less risk. The system 10 can be any length and spacing, may eliminate the need for a wet-connector for fiber optics, and allows for monitoring while fracing.

[0050] As noted above in Figures 1 and 2A, the system 10 can be used in cased borehole having casing 12 with perforations 13. Other completion arrangements can be used. For example, instead of the borehole having perforated casing 12, the borehole can have an expandable pre-slotted or pre-perforated liner 17a as in Figure 2B. As is customary, such an expandable liner 17a can be suspended from a liner hanger and packer assembly 17b disposed in casing 12. Below the liner hanger and packer assembly 17b, the expandable liner 17a extends into an open borehole section. The expandable liner 17a can have slots or perforations (not shown) in those zones of the formation to be produced. Although not shown, the expandable liner 17a can be constructed to suit the zones of the formation using modular components, including expandable liner or sand screen sections, blank pipe sections, and expandable zonal isolation joints, such as are available in Weatherford's Expandable Reservoir Completion systems.

[0051] How the liner hanger and packer assembly 17b and the expandable liner 17a are installed in the borehole will be appreciated by

one skilled in the art with the benefit of the present disclosure so that particular details are not provided here. Briefly though, the liner hanger and packer assembly 17b and expandable liner 17a are disposed downhole, and the hanger and packer assembly 17b is set by dropping a ball and applying pressure. Expansion of the liner 17a is then performed using liner expansion tools. Once the liner 17a is set, frac operations can be performed by deploying the frac assembly 20 as described previously.

[0052] Other than a cased or lined borehole as noted above, the multi-zone screened frac system 10 can also be used for open hole completions. In a third embodiment according to the present disclosure, for example, the multi-zone screened frac system 10 of Figure 3 is used for an open hole completion and has many of the same components as described previously so that like reference numeral are used for similar components. In contrast to the cased or lined hole arrangements of Figures 1 and 2A-2B, open hole packers 19 are used for this system 10 in Figure 3. These packers 19 can be swellable and/or hydraulic set packers for open holes.

[0053] After fracing operations, the system 10 may need a clean-out operation. As before, the frac valves 30 are disposed uphole of the flow devices 40, but they could be disposed downhole of the flow devices 40 in each section 28. As another alternative, slurry de-hydration tubes (not shown) could also be used along the assembly 10.

[0054] The multi-zone frac system 10 of Figure 3 provides the highest rates and improved reservoir performance. The system 10 can be of any length and any spacing. The system 10 does not require perforating to be performed and offers the option to step down one casing size in its implementation, which can give significant savings potential. Finally, the system 10 does not need wet-connectors for using fiber optics, and the system 10 allows for monitoring while fracing.

[0055] In a fourth embodiment according to the present disclosure, the multi-zone screened frac system 10 in Figure 4 is also used for openhole completions as with the embodiment of Figure 3. In contrast to previous

arrangements, this system 10 has a workstring 70 that disposes in the frac assembly 20 to open the various frac valves 30 and treat portions of the formation. As shown, the workstring 70 has external seals 76 disposed near outlet ports 72. A dropped ball 74 can seat in a distal seat of the workstring 70 to divert fluid flow down the workstring 70, out the outlet ports 72, and to the open ports 32 in the frac valve 30 to treat the surrounding formation.

[0056] The frac operation for the system 10 of Figure 4 involves running the assembly 20 downhole and setting the packers 19 to create the multiple isolated sections 28 down the borehole annulus 15. Once the packers 19 are set, operators apply a frac treatment successively to each of the isolated sections 28 by selectively opening the selective frac valves 30 with a shifting tool 78 on the workstring 70 since dropped balls are not used.

[0057] Details about opening the frac valves 30 are provided below with reference to Figures 7A-7B and 8A-8B. In general, the shifting tool 78 can be a "B" shifting tool for shifting the inner sleeve 34 in the frac valve 30 relative to the valve's ports 32. Thus, opening a given frac valve 30 involves engaging the shifting tool 78 in an appropriate profile of the valve's inner sleeve 34 and moving the inner sleeve 34 with the workstring 70 to an opened condition so that the assembly's through-bore 25 communicates with the borehole annulus 15 via the now opened ports 32.

[0058] Once a given frac valve 30 is opened, the seals 76 on the workstring 70 can engage and seal against inner seats 38, surfaces, seals, or the like in the frac valve 30 or elsewhere in the assembly 20 on both the uphole and downhole sides of the opened ports 32. The seals 76 can use elastomeric or other types of seals disposed on the inner workstring 70, and the seats 38 can be polished seats or surfaces inside the frac valve 30 or other parts of the assembly 20 to engage the seals 76. Although shown with this configuration, the reverse arrangement can be used with seals on the inside of the frac valve 30 or assembly 20 and with seats on the workstring 70.

[0059] Once the workstring 70 is seated, treatment fluid is flowed down the through-bore 75 of the workstring 70 to the sealed and opened ports 32 in the frac valve 30. The treatment fluid flows through the outlet ports 72 in the workstring 70 and through the opened ports 32 to the surrounding borehole annulus 15, which allows the treatment fluid to interact with the adjacent zone of the formation.

[0060] Once treatment is completed for the given zone, operators manipulate the workstring 70 to engage the shifting tool 78 in the frac valve 30 to close the ports 32. For example, the shifting tool 78 can engage another suitable profile on the inner sleeve 34 of the frac valve 30 to move the sleeve 34 and close the ports 32. At this point, the workstring 70 can be moved in the assembly 20 to open another one of the frac valves 30 to perform treatment. Operators repeat this process up the assembly 20 to treat all of the sections 28. Once the frac treatment is complete, the system 10 may not need a clean-out trip.

[0061] The multi-zone frac system 10 of Figure 4 can have higher rates compared to a conventional single trip multi-zone system and can improve reservoir performance. The system 10 can have any suitable length and spacing, offers the option to step down one casing size, does not require perforating, and does not require a clean-out trip. Consideration should be given to potential sticking the workstring 70 during operation and to annulus packing that can occur for a particular implementation.

[0062] In a fifth embodiment, the multi-zone screened frac system 10 of Figure 5 also has a workstring 70, as with the previous embodiment of Figure 4. In addition to all of the same components, this system 10 has slurry dehydration tubes 80 disposed along the various sections 28.

[0063] During a frac operation similar to that discussed above, the tubes 80 help dehydrate slurry intended to gravel pack the borehole annulus 15 of the sections 28 during a frac pack type of operation. In addition, the tubes 80 can act as a bypass for fluid returns during the operation. As treatment fluid flows from the workstring 70 seated in a frac valve 30, through the opened ports 32, and into the borehole annulus 15, the

wellscreen 46 screens fluid returns from the annulus 15, and the fluid returns can flow into the assembly 20 downhole of the engagement of the workstring 70 in the assembly 20. The tubes 80 can, therefore, allow these fluid returns to flow from the downhole section of the assembly 20 to the micro-annulus between the workstring 70 and the inside of the assembly 20 uphole of the sealed engagement of the workstring 70 with the ports 32. From this point, the fluid returns can then flow to the surface.

[0064] The multi-zone frac system 10 of Figure 5 can have higher rates compared to a conventional single trip multi-zone system 10 and can improve reservoir performance. Furthermore, the system 10 can have any length and spacing, offers the option to step down one casing size, does not require perforating, does not require a clean-out trip, and can give good annulus packing. Consideration should be given to potential sticking of the workstring 70 for a particular implementation.

[0065] As noted above, the various embodiments of the multi-zone frac system 10 in Figures 1-5 use flow devices 40 disposed on the frac assembly 20, and the flow devices 40 includes wellscreens 46 and closure element 48 (*i.e.*, one-way or check valves). Turning now to Figures 6A-6B, a flow device 150 that can be used for the disclosed systems 10 is shown in a partial cross-sectional view and a detailed view, respectively. The flow device 150 is a screen joint having a screen jacket 160 (*i.e.*, wellscreen) and an inflow control device 170 (*i.e.*, one-way or check valve) disposed on a basepipe 152. (Figure 6C shows the inflow control device 170 in an isolated view without the basepipe 152 and the screen jacket 160.)

[0066] The flow device 150 is deployed on a completion string (22: Figs. 1-5) with the screen jacket 160 typically mounted upstream of the inflow control device 170, although this may not be strictly necessary. The basepipe 152 defines a through-bore 155 and has a coupling crossover 156 at one end for connecting to another joint or the like. The other end 154 can connect to a crossover (not shown) of another joint on the

completion string (22). Inside the through-bore 155, the basepipe 152 defines pipe ports 158 where the inflow control device 170 is disposed.

[0067] As noted above, the inflow control device 170 can be similar to a FloReg deploy-assist (DA) device available from Weatherford International. As best shown in Figure 6B, the inflow control device 170 has an outer sleeve 172 disposed about the basepipe 152 at the location of the pipe ports 158. A first end-ring 174 seals to the basepipe 152 with a seal element 175, and a second end-ring 176 attaches to the end of the screen jacket 160. Overall, the sleeve 172 defines an annular space around the basepipe 152 communicating the pipe ports 158 with the screen jacket 160. The second end-ring 176 has flow ports 180 that separate the sleeve's annular space into a first inner space 186 communicating with the screen 160 and second inner space 188 communicating with the pipe ports 158.

[0068] For its part, the screen jacket 160 is disposed around the outside of the basepipe 152. As shown, the screen jacket 160 can be a wire wrapped screen having rods or ribs 164 arranged longitudinally along the base pipe 152 with windings of wire 162 wrapped thereabout to form various slots. Fluid can pass from the surrounding borehole annulus to the annular gap between the screen jacket 160 and the basepipe 152. Although shown as a wire-wrapped screen, the screen jacket 160 can use any other form of screen assembly, including metal mesh screens, pre-packed screens, protective shell screens, expandable sand screens, or screens of other construction.

[0069] Internally, the inflow control device 170 has a number (*e.g.*, ten) of flow ports 180. Rather than providing a predetermined pressure drop along the screen jacket 160 by using multiple open or closed nozzles (not shown), the inflow control device 170 as shown in Figures 6A-6C may lack the typically used restrictive nozzles and closing pins for the internal flow ports 180. Instead, the flow ports 180 may be relatively unrestricted flow passages and may lack the typical nozzles, although a given

implementation may use such nozzles if a pressure drop is desired from the screen jacket 160 to the basepipe 152.

[0070] Internally, however, the inflow control device 170 does include port isolation balls 182, which allow the device 170 to operate as a one-way or check valve. Depending on the direction of flow or pressure differential between the inner spaces 186 and 188, the port isolation balls 182 can move to an open condition (to the right in Fig. 6B) permitting fluid communication from the screen's inner space 186 to the pipe's inner space 188 or to a closed condition (to the left in Fig. 6B against a seat end 184 of the flow port 180) preventing fluid communication from the pipe's inner space 188 to the screen's inner space 186.

[0071] In general, the inflow control device 170 can facilitate fluid circulation during deployment and well cleanup and can be used in interventionless deployment and setting of openhole packers. In deployment, for example, the isolation balls 182 maximize fluid circulation through the completion shoe (50: Figs. 1-5) of the frac assembly (20) to aid efficient deployment of the completion string (22) and assembly (20). When the housing components (172, 174, 175, & 176) are disposed on the basepipe 150, the isolation balls 182 are retained in-place. During initial installation and production, the isolation balls 182 can prevent formation surging, thereby reducing damage to the formation. In some arrangements, the isolation balls 182 within the device 170 can be configured to erode over a period of time, allowing access to the interval for workover activity such as stimulation.

[0072] Should a pressure drop be desired from the screen jacket 160 to the basepipe 152, the flow ports 180 can include nozzles (not shown) that restrict flow of screened fluid (*i.e.*, inflow) from the screen jacket 160 to the pipe's inner space 188. For example, the inflow control device 170 can have ten nozzles, although they all may not be open. Operators can set a number of these nozzles open at the surface to configure the device 170 for use downhole in a given implementation. Depending on the number of

open nozzles, the device 170 can thereby produce a configurable pressure drop along the string of such flow devices 150.

[0073] As noted above, the various embodiments of the multi-zone frac system 10 in Figures 1-5 use frac valves 30 disposed on the frac assembly 20 that can be opened and closed to communicate ports 32 with the borehole annulus 15. Turning now to Figures 7A-7B, a frac valve 210 for the disclosed multi-zone screen frac system 10 is shown in partial cross-section in a closed state (Fig. 7A) and an opened state (Fig. 7B). As noted above, the frac valve 210 can be a sliding sleeve similar to Weatherford's ZoneSelect MultiShift frac sliding sleeve and can be placed between isolation packers in the multi-zone completion. The sliding sleeve 210 includes a housing 220 with upper and lower subs 222 and 224. A closure element 230, such as an inner sleeve or insert, movable within the housing 220 opens or closes fluid flow through the housing's flow ports 226 based on the inner sleeve 230's position.

[0074] When initially run downhole, the inner sleeve 230 positions in the housing 220 in a closed state (Fig. 7A). In this state, a holder 235 holds the inner sleeve 230 toward the upper sub 222, and a locking ring or dogs 238 fit into an annular slot within the housing 220. Outer seals 236 on the inner sleeve 230 engage the housing 220's inner wall both above and below the flow ports 226 to seal them off. In addition, the flow ports 226 may be covered by a protective sheath 227 to prevent debris from entering into the sliding sleeve apparatus 210. Such a sheath 227 can be composed of a destructible material, such as a composite.

[0075] As noted previously with respect to Figures 1-3, the sliding sleeve 210 is designed to open when a ball 36 lands on the landing seat 232 and tubing pressure is applied to move the inner sleeve 230 open. To open the sliding sleeve 210 in a frac operation, for example, operators drop an appropriately sized ball 36 downhole and pump the ball 36 until it reaches the landing seat 232 disposed in the inner sleeve 230 as shown in Figure 7B. The designated ball 36 for the landing seat 232 of this particular

sleeve 210 is dropped from the surface once the appropriate amount of proppant has been pumped into the lower formation's zone.

[0076] Once the ball 36 is seated, built up pressure forces against the inner sleeve 230 in the housing 220, thereby shearing away from the holder 235 and freeing the dogs 238 from the housing's annular slot to the inner sleeve 230 can slide downward. As it slides, the inner sleeve 230 uncovers the flow ports 226. Preferably, as the inner sleeve 230 shifts past the flow ports 226, fracturing does not occur through the inner sleeve 230, which protects it from erosion.

[0077] To mitigate potential damage to the sleeve 210 as the inner sleeve 230 moves downward, a shock absorber 240 can be connected to the inner sleeve 230's lower end. As shown in Figure 7A, this shock absorber 240 is initially connected in an extended position by shear pins 242 within the inner sleeve 230. As the inner sleeve 230 moves downward during opening, the absorber's distal lip 245 engages a shoulder 225 on the housing's lower sub 224, thereby breaking the downward energy of the moving inner sleeve 230.

[0078] After the fracturing job, the well is typically flowed clean and the ball seat 232 and remaining ball 36 is milled out. The ball seat 232 can be constructed from cast iron to facilitate milling, and the balls 36 can be composed of aluminum or non-metallic material. Once milling is complete, the inner sleeve 230 can be closed or opened with a standard "B" shifting tool on the tool profiles 234 and 236 in the inner sleeve 230 so the sliding sleeve 210 can then function like any conventional sliding sleeve shifting with a "B" tool. The ability to selectively open and close the sliding sleeve 210 with a "B" shifting tool after milling enables operators to isolate the particular section (28: Figs. 1-5) of the assembly (20).

[0079] For those embodiments of the disclosed multi-zone screen frac system 10 that do not use a ball and seat arrangement, such as in Figures 4-5, the sliding sleeve 210 may lack a seat 232 altogether. Instead as noted above, the workstring (70: Figs. 4-5) has a shifting tool (78), such as a standard "B" shifting tool, that can engage on the tool profiles 234 and

236 in the inner sleeve 230 so the workstring 70 can selectively move the inner sleeve 230 and open and close the ports 226.

[0080] Turning now to Figures 8A-8B, details of a shifting tools 78 for the workstring 70 of Figures 4-5 are discussed. As shown for the shifting tool 78 in Figure 8A, a mandrel 302 is disposed between upper and lower sections of the workstring 70 and has upper and lower shifting elements 310 and 320. Because the mandrel 302 is part of the workstring 70, it may have a bore (not shown) therethrough for flow of fluid.

[0081] In the present example, the upper element 310 is designed to be a closing tool for closing a sliding sleeve (e.g., 210: Figs. 7A-7B) by engaging the upper profile (234), jarring up of the workstring 70, and shifting the inner sleeve (230) upward in the sliding sleeve (210). Likewise in this example, the lower element 320 is designed to be an opening tool for opening the sliding sleeve (210) by engaging the lower profile (236), jarring down with the workstring 70, and shifting the inner sleeve (230) downward in the sliding sleeve (210). A reverse arrangement could also be used.

[0082] As shown in the detailed cutaway, the closing shifting element 310 has a biased collet 312 that fits around the mandrel 302 and that connects at both ends to stops 314 and 316 on the mandrel 302. The collet 312 has B-profiles 318 that include an upward facing shoulder, an upper (shortened) cam, and a lower (extended) cam. As discussed above, the B-profiles 318 enable the collet 312 to engage the recessed profile (234) in the sliding sleeve (210) in the up direction and bypass the recessed profiles (234 and 236) in the sliding sleeve (210) in the down direction. This type of shifting element is typically referred to as a B shifting tool with a B-profile.

[0083] Another arrangement of the shifting tool 78 uses a two-way shifting element 330 as shown in Figure 8B. Here, the two-way shifting element 330 has a biased collet 332 that fits around the mandrel 302 and that connects at both ends to stops 334 and 336 on the mandrel 302. The collet 332 has dual B-profiles 328 having a downward-facing shoulder 340,

an upper cam 342, an upward-facing shoulder 345, and a lower cam 347. Depending on the configuration of the sliding sleeve (210) and its profiles (234 and 236) and the direction the workstring 70 is being moved, the shifting tool 330 can open/close the sliding sleeve (210) by jarring down/up.

[0084] Figures 9A-9D illustrate another multi-zone screened frac system 10 according to the present disclosure used for an open hole completion. As with some previous arrangements, the system 10 has a workstring 70 that disposes in the frac assembly 20 to open the various frac valves 30 and treat portions of the formation, but the workstring 70 in this arrangement does not seal inside the assembly 20 when delivering the treatment at various points in the formation.

[0085] As shown, a service packer 17 can be used between the workstring 70 and the casing 12 to isolate the internal through-bore 25 of the assembly 20. As also shown, the workstring 70 has a service tool 77 disposed above the liner packer 16. The service tool 77 can be used for hydraulically setting the packer 16. Regardless of the configuration used, the uphole components of the system 10 can be used for circulating, squeeze, and reverse out operations as is known in the art.

[0086] The workstring 70 has one or more outlet ports 72 and has hydraulically actuated shifting tools 78a-b. Both of the shifting tools 78a-b can be actuated with applied pressure against a ball (74: Fig. 9B) when seated in the workstring 70. One shifting tool 78b can open the frac valves 30 when the workstring 70 is run downhole in the assembly 20, while the other shifting tool 78a can close the frac valves 30 when the workstring 70 is run uphole in the assembly 20. The same can be true for opening and closing the flow devices 40 with the shifting tools 78a-b as discussed below. Thus, one shifting tool 78b is run facing down, while the other tool 78a is run facing up. Other arrangements can be used, and other types of shifting tools can be used as well.

[0087] As an example, the shifting tools 78a-b can each be a hydraulically actuated version of an industry standard B shifting tool.

When the shifting ball (74) is dropped in the workstring 70, the application of hydraulic pressure down the workstring 70 actuates the shifting tools 78a-b so that they expose spring-loaded keys for shifting the frac valves 30 and flow devices 40 open or closed. The shifting tools 78a-b may be actuated together with the same ball 74 or actuated separately with different sized balls 74 depending on the configuration.

[0088] As before, the frac assembly 20 has a production string 22 supported from a packer 16 in the casing 12. Along its length, the string 22 has isolation devices 19, frac valves 30, and flow devices 40. The isolation devices 19, which can be packers, seal the borehole annulus 15 around the assembly 20 and separate the annulus 15 into various zones or sections 28A-C. Each section 28A-C has at least one of the frac valves 30 and at least one of the flow devices 40, both of which can selectively communicate the string's through-bore 25 with the borehole annulus 15 as detailed below. At its downhole end, the frac assembly 20 has a bottom seat 50 for engaging a setting ball 54 to close off the shoe 26 during frac operations.

[0089] As shown, the selective frac valve 30 is disposed uphole of the flow device 40 in each of the various sections 28A-C. As an alternative, the selective frac valve 30 can be disposed downhole of the flow device 40 in each section 28A-C. Moreover, a given section 28A-C may have more than one frac valve 30 and/or flow device 40.

[0090] The selective frac valves 30 have one or more ports 32 that can be selectively opened and closed during operation. In this arrangement as with others discussed above, each of the selective frac valves 30 can be opened to communicate their ports 32 with the surrounding annulus 15 by using the shifting tool 78a on the workstring 70. As before, the frac valves 30 can be sliding sleeves having a movable closure element 34, such as an inner sleeve or insert, which isolates or exposes ports 32 in the sliding sleeve's housing.

[0091] Similar to the frac valves 30, the flow devices 40 also have one or more ports 42 that can be selectively opened and closed during operation.

Each of the flow devices 40 also includes a closure and a screen 46. The closure in this arrangement includes a first closure element 44 that selectively opens and closes flow through the flow ports 42 and includes a second closure element 48 that at least prevents fluid flow from the through-bore 25 through the screen 46.

[0092] This assembly 10 is a single trip, multi-zone frac system as discussed in previous embodiments. Briefly, the assembly 20 is run downhole as part of the production string 22 or liner system deployed in the borehole, and the liner packer 16 is set hydraulically. Frac treatments are then performed for the various zones or sections 28A-B of the borehole annulus 15 by selectively opening the frac valves 30.

[0093] After fracing is completed, excess proppant is cleaned out of the assembly 20, and the frac valves 30 are closed because they are used primarily for outlet ports for the frac treatment. To prepare the assembly 20 for production, the flow devices 40 are then opened in the assembly 20 with the workstring 70 in the same trip in the wellbore by opening the first closure element 44 (e.g., inner sleeve) to expose the flow ports 42. Once open, the flow devices 40 screen fluid from the borehole annulus 15 into the string's through-bore 25. At the same time, the flow device's second closure element 48 functions to prevent flow in the reverse direction. As discussed in more detail below, for example, the flow device's second closure element 48, which can use one-way or check valve, can prevent fluid loss into the formation while pulling out the workstring 70 from the assembly 20 and while performing production.

[0094] With a general understanding of how the assembly 20 is used, discussion now turns to how frac operations are performed in more detail. Initially, all of the frac valves 30 and flow devices 40 are closed on the assembly 20 when run in the borehole. After setting the liner packer 16 and closing off the bottom seat 50 with the setting ball 54, operators set the packers 19 along the assembly 20 with the appropriate procedures to create the multiple isolated sections 28A-C down the borehole annulus 15. Once the packers 19 are set, operators can then commence with applying

frac treatment successively to each of the isolated sections 28A-C by selectively opening and then closing the selective frac valves 30 with the shifting tools 78a-b on the workstring 70.

[0095] As shown in Figure 9A, for example, the selective frac valve 30 for the lower section 28A is opened, but its accompanying flow device 40 remains closed. To open this lower frac valve 30, operators position the workstring 70 near the frac valve 30 and drop the shifter ball (74) to the shifting tools 78a-b on the workstring 70. Operators then pressure up the workstring 70, and the applied pressure in the workstring's bore 75 acts against the seated ball (74) and actuates the shifting tools 78a-b. Using the opening tool (e.g., 78b), operators open the frac valve 30 (e.g., by shifting the inner sleeve 34 in the valve 30 open). Once the frac valve 30 is open, operators then bleed off the applied pressure and reverse the flow so that the seated ball (74) in the workstring 70 can be reversed out through the workstring's bore 75 to the surface.

[0096] For example, the flow device 40 can be a sliding sleeve having a movable closure element 44, such as an inner sleeve or insert, which isolates or exposes the ports 42 in the sliding sleeve's housing. The flow device 40 can be opened to communicate its ports 42 with the surrounding annulus 15 through its screen 46 by using the shifting tool 78a on the workstring 70. In this way, the flow device 40 when closed does not communicate the string's through-bore 25 with the borehole annulus 15 through screens 46, but the flow device 40 when opened allows screened fluid from the annulus 15 to pass through the screen 46 on the device 40 and into the through-bore 25.

[0097] Now, operators position the workstring 70 uphole of the open frac valve 30 as shown in Figure 9A. In manipulating the workstring 70 in the assembly 20, the workstring 70 is positioned unsealed in the assembly's through-bore 25 relative to the open ports 32 in the frac valve 30. In other words, the workstring 70 at the section 28A to be treated is not engaged with seals or seats inside the assembly's through-bore 25 as in previous embodiment.

[0098] Without sealing the workstring 70 in the assembly's section 28A, operators apply the frac treatment down the workstring 70 to treat the borehole annulus 15 for this section 28A. The fluid leaves the ports 72 in the workstring 70 and flows along a first flow path through the open ports 32 of the frac valve 30 and into the formation around the open section's borehole annulus 15. To maintain the pressure in the assembly 20 during the frac operation, the system 10 can use a live annulus technique (if the service packer 17 is not used or can be removed, or the system 10 can use a pure squeeze technique with the service packer 17 in the casing 12.

[0099] At the same time as the frac treatment, the closure on the flow device 40 at least prevents fluid flow through the ports 42 and screen 46 from the through-bore 25 to the borehole annulus 15. Preventing the flow out of the screen 46 can be accomplished by either the first or second closure elements 44 and 48 or by both. Preferably, the first closure element 44 also prevents fluid flow from the borehole annulus 15 into the through-bore 25 via the screen 46.

[00100] Once treatment of the first section 28A is done, operators reverse out at least some of the excess slurry from the workstring 70 so treatment can commence with the next section 28B. As then shown in Figure 9B, operators drop the shifter ball 74 down the workstring 70 again, and pressure up the workstring 70 to actuate the shifting tools 78a-b with the seated ball 74. With the tools 78a-b actuated, operators close the open frac valve 30 for the lower section 28A with the closing tool 78a. After bleeding off the pressure, the workstring 70 is raised to the frac valve 30 in the next section 28B. At this point, operators then pressure up on the seated shifter ball 74 in the workstring 70 again and open this frac valve 30 with the actuated opening tool 78b. After bleeding off the applied pressure in the workstring 70 and reversing out the seated ball 74, the treatment process for this new section 28B is then repeated as before.

[00101] Similar procedures are then repeated for all of the subsequent sections (*i.e.*, 28C) of the assembly 20. Once treatment is complete for all of the sections 28A-C as then shown in Figure 9C, all of the frac valves 30

and flow device 40 on the assembly 20 are closed. Operators perform a washout operation. To do this, the workstring 70 is lowered down toward the shoe 26 of the assembly 20, and operators pump a washout fluid down the casing 12 to reverse out any residual frac proppant or other treatment up the workstring 70. Because all of the frac valves 30 are closed, operators have no issues with reversing flow for the washout operation.

[00102] When washout is complete, operators then open all of the flow devices 40 so their ports 42 communicate with the string's through-bore 25 to accept production. The workstring 70 positions toward the bottom shoe 26, and operators drop the shifter ball 74 again. Pressure is applied to the seated ball 74 to actuate the shifter tools 78a-b on the workstring 70, and operators raise the workstring 70 and open the first closure elements 44 (e.g., inner sleeve) of the flow devices 40 up the assembly 20 using the opening tool 78b.

[00103] As the flow devices 40 are opened, fluid from the borehole annulus 15 can flow along a second flow path through the screens 46, closure elements 48, and opened ports 42. As the flow devices 40 are opened up the assembly 20, the second closure elements 48 (e.g., one-way or check valves) of the flow devices 40 prevent fluid loss from the string's through-bore 25 to the annulus 15 during this process. As shown in Figure 9D, once all of the flow devices 40 are open, the workstring 70 is removed from the assembly 20. At this point, the assembly 20 is prepared to receive production through the screens 46, closure elements 48, and opened ports 42 via the second flow path.

[00104] As can be seen, operation of this system 10 can reduce the time and risk involved in performing the treatment because no service tool needs to seal in the assembly 20. Moreover, pickup and operations time are reduced. Essentially, the workstring 70 can be run in during the liner setting trip so that no added runs are needed. Cleanout and opening/closing of the ports 32 and 42 in the frac valves 30 and flow devices 40 are all done in the same trip.

[00105] The present example of the system 10 is described for an open hole, but the system 10 for a cased hole would be the same except that the isolation packers 19 may be different. Because the system 10 does not use dropped balls in the assembly 20 to open the frac valve 30 or flow devices 40, the number of stages that can be deployed downhole is not limited by the required step-down sizes in balls and seats. Moreover, no balls or seats are left in the assembly 20 after treatment operations so the operation does not need a separate milling operation, which can be time consuming and can encounter its own issues. In essence, the wellbore is ready to receive production tubing after the frac operation is completed.

[00106] As discussed above, the frac devices 30 in Figures 9A-9D have one or more ports 32 that can be selectively opened/closed to allow/prevent fluid communication from the borehole annulus 15 into the string's through-bore 25. Figures 10A-10B show a multi-shift sliding sleeve 210 for use as a frac valve (30) in the disclosed system (10). Similar to the previous sliding sleeve disclosed above actuated by a seated ball, the sliding sleeve 210 includes a housing 220 with upper and lower subs 222 and 224. A first closure element 230, which is an inner sleeve or insert, is movable within the housing 220 and opens or closes fluid flow through the housing's flow ports 226 based on the inner sleeve 230's position. Rather than using a ball and seat to move the inner sleeve 230, the inner sleeve has profiles 234 and 236 for engaging shifting tools (78a-b) on the workstring (70). As noted above, these profiles 234 and 236 can be standard B-profiles, although other possible configurations can be used.

[00107] As discussed above, the flow devices 40 in Figures 9A-9D also have one or more ports 42 that can be selectively opened/closed with the first closure elements 44 (e.g., inner sleeve) to allow/prevent fluid communication from the borehole annulus 15 into the string's through-bore 25 through the flow devices' screens 46. Additionally, the flow devices' second closure elements 48 (e.g., check valves) prevent loss of fluid flow in the through-bore 25 to the borehole annulus 15 during the opening

process. Figure 11 illustrates a flow device 400 for use in the system 10 of Figs. 9A-9D.

[00108] The flow device 400 fits onto the producing string (22) of the system (10) and has a basepipe 410 with a bore 415 that communicates with the string's through-bore (25). Disposed on both ends of the basepipe 410, the device 400 has wellscreen 420A-B. In general, the wellscreens 420A-B can use any form of screen assembly used for sand control, including wire-wrapped screens, metal mesh screens, pre-packed screens, protective shell screens, expandable sand screens, or screens of other construction.

[00109] As shown in this embodiment, the wellscreens 420A-B are wire-wrapped screens having wires 422 wrapped on longitudinal rods 424 that run along the outside length of the basepipe 410. Far ends (not shown) of the wellscreens 420A-B can have end rings (not shown) so that screened fluid flows towards the central area of the device 400 between the wellscreens 420A-B.

[00110] Between the two wellscreens 420A-B, the device 400 has a central housing 430 that receives the screened flow from the wellscreens 420A-B. The housing 430 has end rings 432 at each end with a central sleeve 434 connected between them. Flow from the wellscreens 420A-B can pass through flow passages in the end rings 432 and can enter a plenum 435 in the housing 430 around the basepipe 410.

[00111] To control the flow of fluid into the basepipe's bore 415 through its inlet ports 412 (and eventually into the assembly's through-bore) through the second flow path through the device 400, the basepipe 410 has a first closure element 440, which is an inner sleeve or insert, disposed in the bore 415 and movable relative to the inlet ports 412. In a closed position (not shown in Fig. 11), the inner sleeve 440 is moved so the sleeve's openings 442 do not align with the inlet ports 412. With the sleeve 440 closed, flow in the housing's plenum 435 cannot pass into the basepipe's bore 415. Seals (not labeled) are provided between the interface of the sleeve 440 and the basepipe's bore 415 to seal off the inlet ports 412.

[00112] When the sleeve 440 is shifted to an open position shown in Figure 11, however, the sleeve 440 is moved so the sleeve's openings 442 align with the inlet ports 412. Flow in the housing's plenum 435 can now pass into the basepipe's bore 415. Other configurations can be used for the inner sleeve 440 that can lack the openings 442 and may instead move fully away from the ports 412 to expose them to the bore 415.

[00113] To prevent loss of fluid in the basepipe's bore 415 to the borehole annulus outside the device 400 during operations as noted above, the housing 430 has a second closure element, such as one-way or check valves, that prevents back flow from the housing's plenum 435 to the wellscreens 420A-B. In the arrangement shown, these closure elements include seats 450 formed inside the flow passages of the housing 430 between the end rings 432 and the plenum 435 and include check balls 455 movably disposed in the housing's plenum 435.

[00114] When regular flow occurs along the second flow path from the wellscreens 420A-B to the inlet ports 412, the check balls 455 move away from the seats 450 allowing the screened fluid to pass, but the check balls 455 remain held in the plenum 435. When reverse flow occurs from the plenum 435 towards the wellscreens 420A-B, by contrast, the check balls 455 engage in the seats 450 and block the flow in this reverse direction. Although the balls 455 are shown entirely free floating in the plenum 435, additional features can restrict the balls' movements to areas close to the seats 450.

[00115] As can be seen, the device 400 can be closed to flow in either direction when the inner sleeve 440 is closed to seal the ports 412. With the inner sleeve 440 opened, flow is allowed in only one direction into the bore 415 due to the check valves (balls 455 and seats 450). Meanwhile, the wellscreens 420A-B prevent the production of solids from the formation into the bore 415. Likewise, the wellscreens 420A-B can prevent frac or gravel pack proppant from flowing into the bore 415 during treatment operations.

[00116] Finally, the seats 450 in the device 400 can be constructed with flow restrictive ports or nozzles to create a pressure drop if desired. When the device 400 is opened, the restrictions allow the device 400 to be used as an inflow control device. Although two wellscreens or sections 420A-B are shown in Figure 11, a comparable flow device 400 can have all of the same components, but may have only one wellscreen and one check ball and seat arrangement on one side of the device's flow ports 412.

[00117] The foregoing description of preferred and other embodiments is not intended to limit or restrict the scope or applicability of the inventive concepts conceived of by the Applicants. It will be appreciated with the benefit of the present disclosure that features described above in accordance with any embodiment or aspect of the disclosed subject matter can be utilized, either alone or in combination, with any other described feature, in any other embodiment or aspect of the disclosed subject matter.

[00118] Moreover, the systems have been described herein as single trip, multi-zone frac systems. As will be appreciated, in addition to frac treatment, certain embodiments of the disclosed systems can be configured and used for other types of formation treatments, such as acidizing treatments and the like, and can be used for gravel pack and frac pack operations when configured to handle fluid returns from the borehole annulus 15 with one or more flow tubes or other features as disclosed herein.

[00119] In exchange for disclosing the inventive concepts contained herein, the Applicants desire all patent rights afforded by the appended claims. Therefore, it is intended that the appended claims include all modifications and alterations to the full extent that they come within the scope of the following claims or the equivalents thereof.

WHAT IS CLAIMED IS:

1. A multi-zone formation treatment assembly for a borehole, comprising:
 - a tubular structure disposed in the borehole and defining a through-bore;
 - a plurality of sections disposed on the tubular structure, each of the sections comprising:
 - an isolation element disposed on the tubular structure and isolating a borehole annulus around the section from the other sections,
 - a flow valve disposed on the tubular structure and selectively operable between opened and closed conditions permitting and preventing fluid communication between the through-bore and the borehole annulus,
 - a screen disposed on the tubular structure and communicating with the borehole annulus, and
 - a closure disposed on the tubular structure and at least preventing fluid communication from the through-bore to the screen; and
 - a workstring defining an outlet and being manipulated in the tubular structure relative to each section in the same trip to: open the flow valve, position in the through-bore relative to the open flow valve, deliver the treatment from the outlet to the section through the open flow valve, and close the flow valve.
2. The assembly of claim 1, wherein the isolation element comprises a swellable packer, a hydraulically-set packer, or a mechanically-set packer.

3. The system of claim 1, wherein the flow valve comprises a sleeve movable in the through-bore between (a) the closed condition preventing fluid communication through at least one flow port in the tubular structure and (b) the opened condition permitting fluid communication through the at least one flow port.
4. The assembly of claim 1, wherein the closure is selectively operable between (a) a closed condition preventing fluid communication between the through-bore and the screen and (b) an opened condition permitting fluid communication between the through-bore and the screen.
5. The assembly of claim 4, wherein the closure comprises a sleeve movable in the through-bore between (a) the closed condition preventing fluid communication through at least one flow port in the tubular structure, the at least one flow port in communication with the screen, and (b) the open condition permitting fluid communication through the at least one flow port.
6. The assembly of claim 1, wherein the closure comprises a one-way valve disposed on the tubular structure and in fluid communication between the screen and the through-bore, the one-way valve permitting fluid communication from the screen into the through-bore and preventing fluid communication from the through-bore to the screen.
7. The assembly of claim 6, wherein the one-way valve comprises:
 - a housing disposed on the tubular structure and communicating the screen with at least one flow port in the tubular structure; and
 - a check ball movably disposed in the housing, the check ball permitting fluid communication from the screen to the at least one flow port and preventing fluid communication from the at least one flow port to the screen.

8. The assembly of claim 1, wherein the screen comprises first and second screen sections disposed on the tubular structure on both sides of at least one flow port in the tubular structure, the screen sections communicating with the at least one flow port.

9. The assembly of claim 8, wherein the closure is selectively operable between (a) a closed condition preventing fluid communication through the at least one flow port between the through-bore and the screen sections and (b) an opened condition permitting fluid communication through the at least one flow port between the through-bore and the screen sections.

10. The assembly of claim 9, wherein the closure comprises a sleeve movable in the through-bore between the closed and opened conditions.

11. the assembly of claim 8, wherein the closure comprises a one-way valve disposed on the tubular structure and in fluid communication between the first and second screen sections and the at least one flow port, the one-way valve permitting fluid communication from the first and second screen sections into the at least one flow port and preventing fluid communication from the at least one flow port to the first and second screen sections.

12. The assembly of claim 11, wherein the one-way valve comprises:
a housing disposed on the tubular structure and communicating the screen sections with the at least one flow port; and
first and second check balls movably disposed in the housing, each of the check balls permitting fluid communication from one of the screen sections to the at least one flow port and preventing fluid communication from the at least one flow port to the one screen section.

13. The assembly of claim 1, wherein the workstring is manipulated in the same trip to open the closures after treatment of all of the sections.
14. The assembly of claim 1, wherein workstring comprises an actuating tool operable to open and close the flow valves of the sections in the same trip in the through-bore.
15. The assembly of claim 14, wherein the actuating tool is hydraulically operable.
16. The assembly of claim 14, wherein the actuating tool is operable to at least open the closures of the sections in the same trip in the through-bore.
17. The assembly of claim 1, wherein the workstring positions unsealed in the through-bore relative to the open flow valve.
18. A multi-zone formation treatment assembly for a borehole, comprising:
 - a tubular structure disposed in the borehole and defining a through-bore;
 - a plurality of sections disposed on the tubular structure, each of the sections comprising:
 - means for isolating a borehole annulus of the section from the other sections,
 - means for selectively permitting and preventing fluid communication from the through-bore to the borehole annulus through a first flow path,
 - means for screening fluid communication from the borehole annulus to the through-bore through a second flow path, and

means for at least preventing fluid communication from the through-bore to the borehole annulus through the second flow path; and

a workstring positioning in the through-bore relative to each of the sections and having means for delivering the treatment to each of the sections in the same trip.

19. The assembly of claim 18, wherein the workstring comprises means for actuating the means for selectively permitting and preventing fluid communication from the through-bore to the borehole annulus through the first flow path.

20. The assembly of claim 18, wherein the means for selectively permitting and preventing fluid communication from the through-bore to the borehole annulus through the first flow path comprises means for selectively opening and closing a first flow port in the tubular structure communicating the through-bore with the borehole annulus.

21. The assembly of claim 18, wherein the means for at least preventing fluid communication from the through-bore to the borehole annulus through the second flow path comprises means for selectively permitting and preventing fluid communication from the through-bore to the borehole annulus through the second flow path.

22. The assembly of claim 21, wherein the means for selectively permitting and preventing fluid communication from the through-bore to the borehole annulus through the second flow path comprises means for selectively opening and closing a second flow port in the tubular structure.

23. The assembly of claim 22, wherein the workstring comprises means for actuating the means for selectively opening and closing the second flow port in the tubular structure.

24. The assembly of claim 18, wherein the means for at least preventing fluid communication from the through-bore to the borehole annulus through the second flow path comprises means for exclusively permitting fluid communication of the screened fluid into the through-bore through the second flow path.

25. The assembly of claim 18, wherein the workstring positions unsealed in the through-bore relative to each section.

26. A multi-zone formation treatment method for a borehole, the method comprising:

isolating a borehole annulus of the borehole around an assembly into a plurality of isolated zones, the assembly in each isolated zone having a first port and a screen communicating a through-bore of the assembly with the borehole annulus; positioning a workstring in the through-bore of the assembly; and treating each of the isolated zones without sealing the workstring in the through-bore by:

selectively opening the first port in the assembly at the isolated zone with the workstring,

flowing the treatment down the workstring to the isolated zone through the opened first port,

at least preventing fluid communication from the through-bore to the borehole annulus through the screen on the assembly at the isolated zone, and

selectively closing the first port at the isolated zone with the workstring after treatment.

27. The method of claim 26, wherein positioning the assembly in the borehole comprises positioning the assembly in casing having perforations, in an expanded liner having slots, or in an open hole.

28. The method of claim 27, wherein isolating the borehole annulus of the borehole around the assembly into the isolated zones comprises engaging isolation elements on the assembly against a wall of the casing, a wall of the expanded liner, or a wall of the open hole.

29. The method of claim 26, wherein positioning the workstring in the through-bore of the assembly comprises positioning the workstring unsealed in the through-bore of the assembly.

30. The method of claim 26, wherein selectively opening the first port in the assembly at the isolated zone with the workstring comprises shifting a sleeve in the assembly away from the first port with the workstring.

31. The method of claim 30, wherein flowing the treatment down the through-bore to the isolated zone through the opened first port comprises flowing the treatment through an outlet in the workstring positioned with respect to the opened first port.

32. The method of claim 26, wherein at least preventing fluid communication from the through-bore to the borehole annulus through the screen on the assembly at the isolated zone comprises selectively preventing fluid communication from the through-bore to the borehole annulus.

33. The method of claim 32, further comprising preparing each of the isolated zones for production by:

selectively opening a second port in the assembly at the isolated zone with the workstring, the second port communicating the through-bore with the screen; and

permitting fluid communication from the borehole annulus into the through-bore through the screen and the opened second port at the isolated zone.

34. The method of claim 33, further comprising screening fluid from the borehole annulus of the isolated zones into the through-bore of the assembly through the screens and the opened second ports.

35. The method of claim 33, further comprising exclusively preventing fluid communication from the through-bore to the borehole annulus of the isolated zones through the screens after selectively opening the second ports.

36. The method of claim 33, wherein selectively opening the second port in the assembly at the isolated zone with the workstring comprises shifting a sleeve in the assembly away from the second port with the workstring.

⊕

1/10

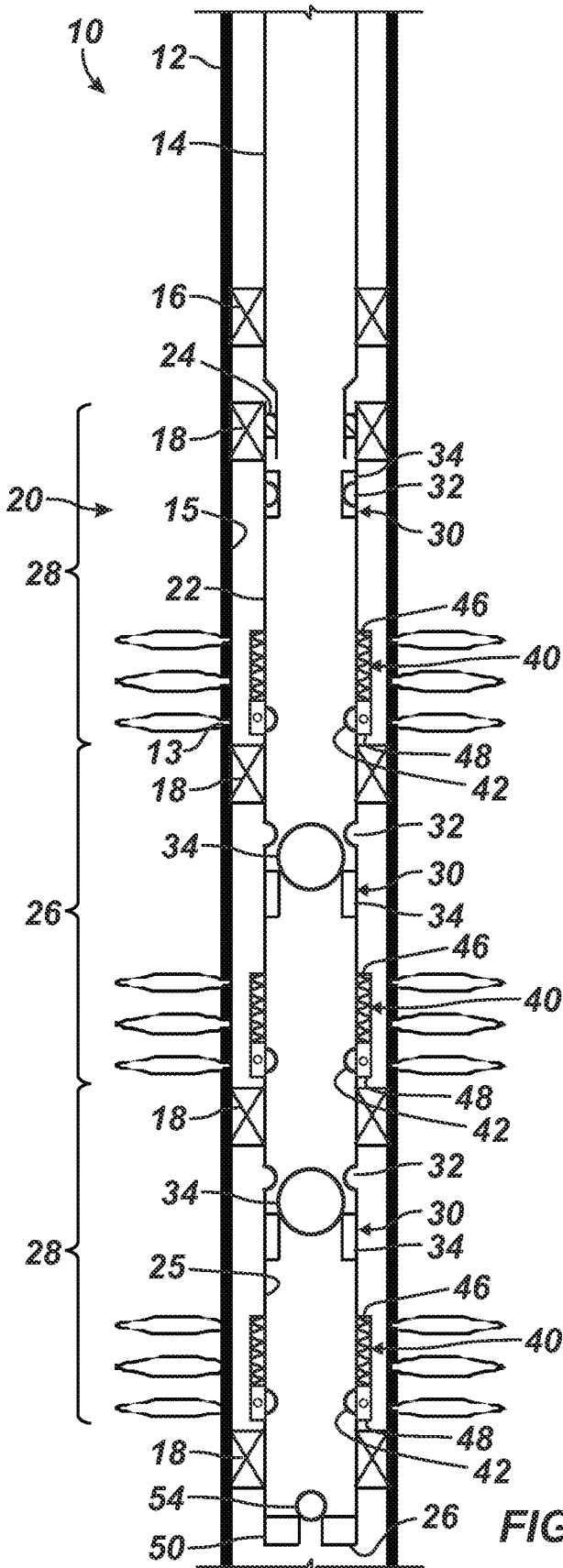

FIG. 1

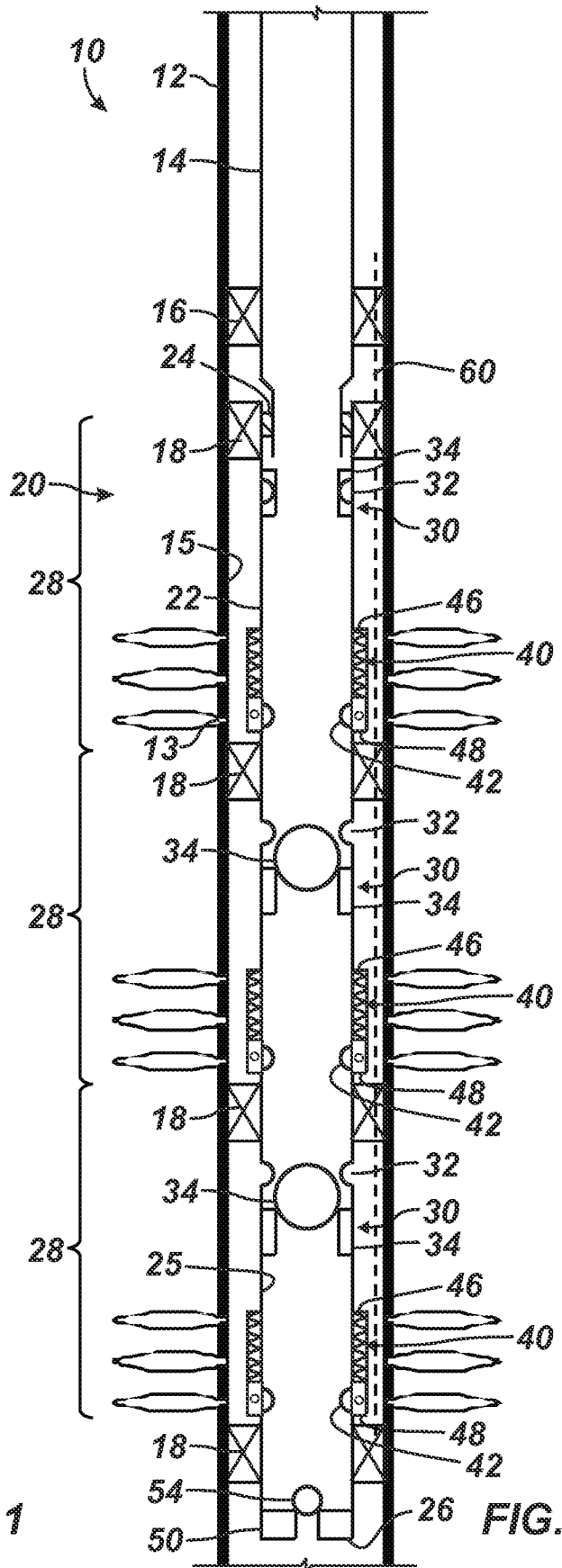
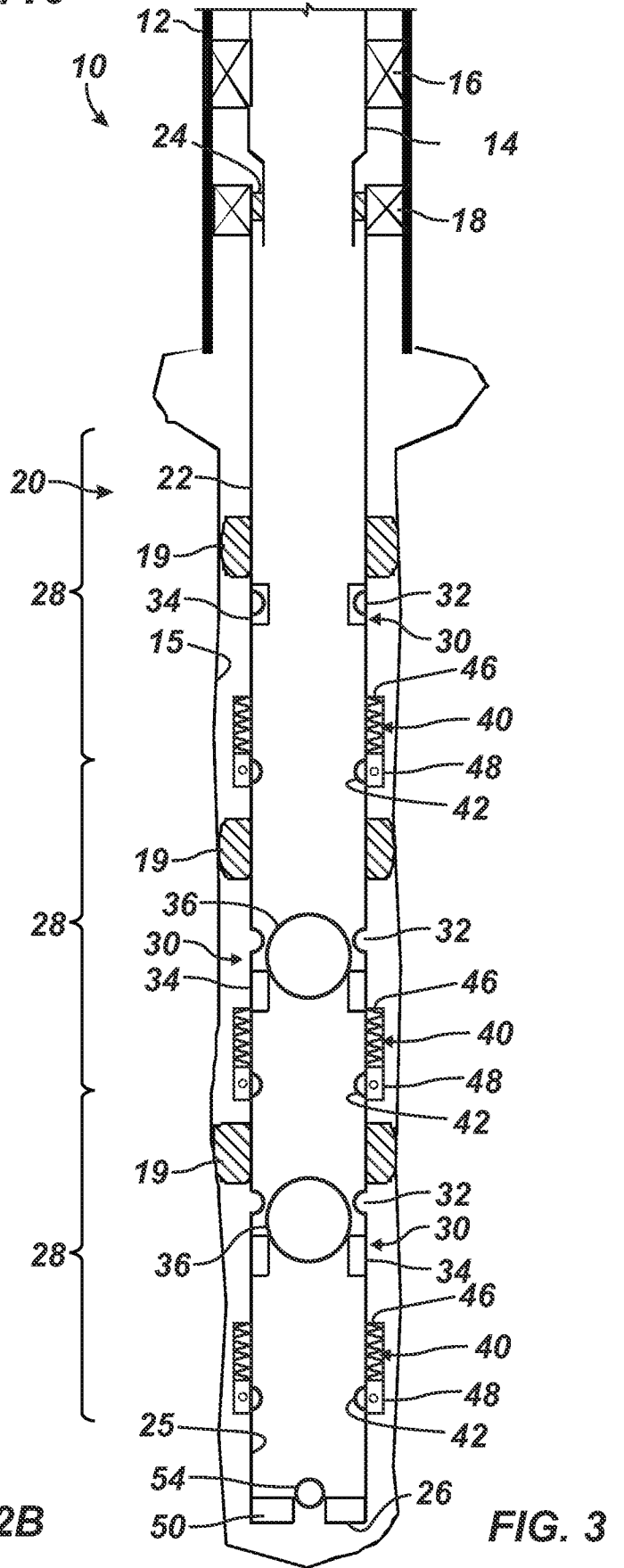
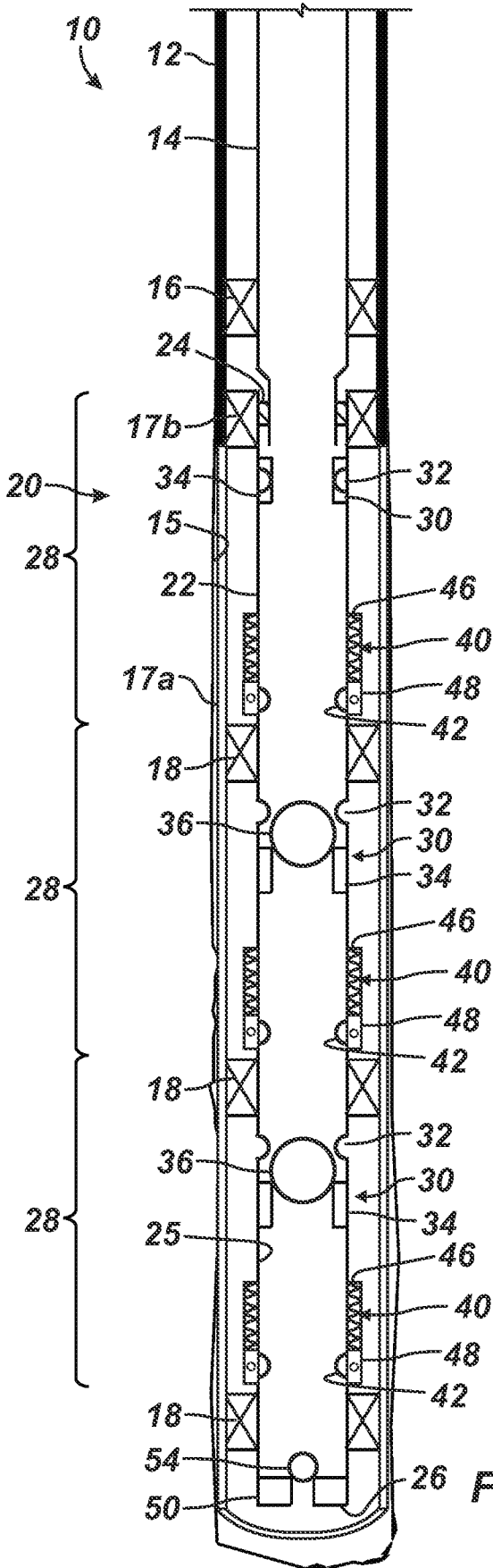

FIG. 2A

⊕

⊕

2/10



⊕

⊕

3/10

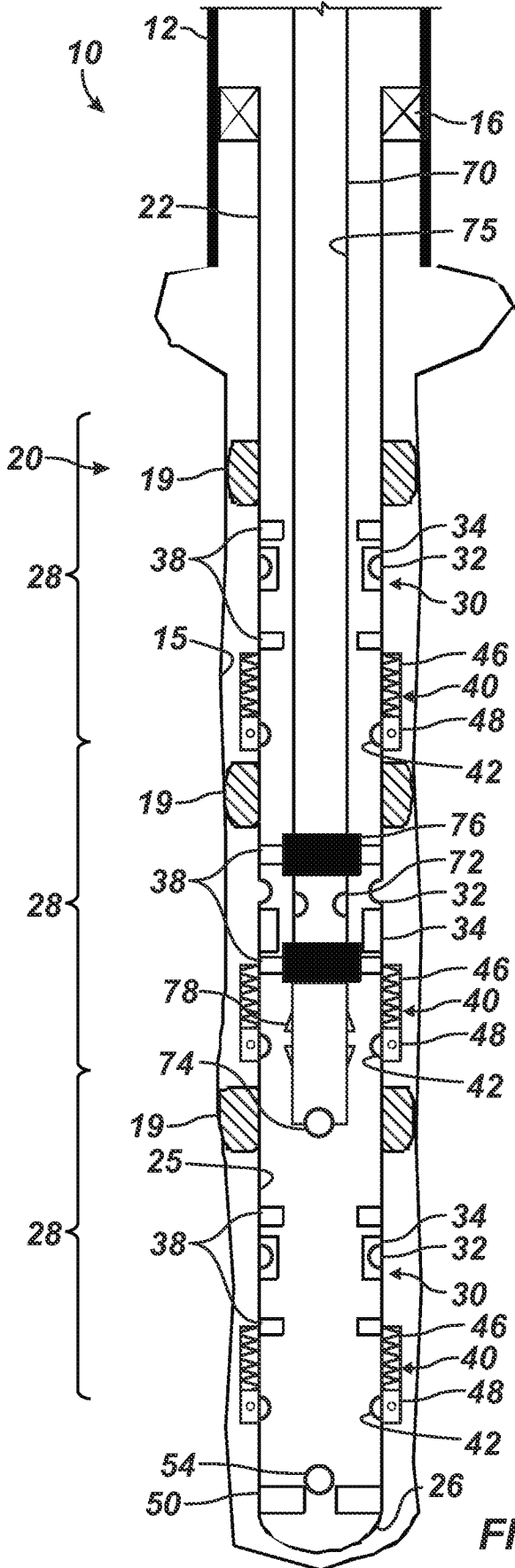

FIG. 4

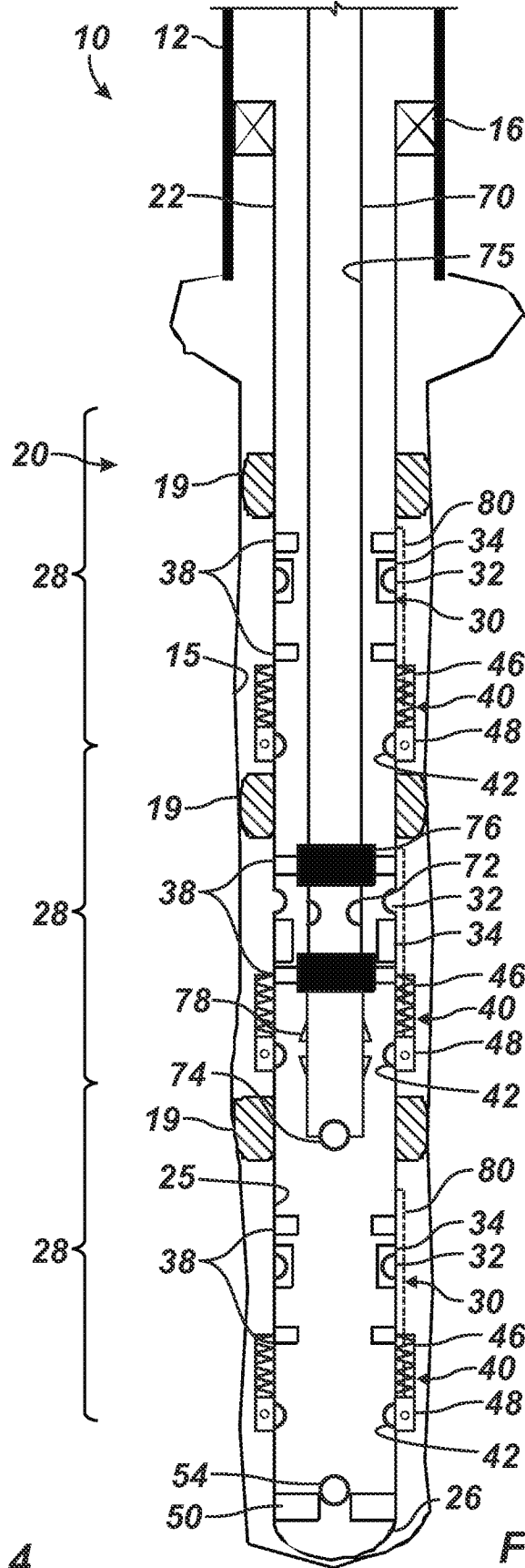

FIG. 5

⊕

4

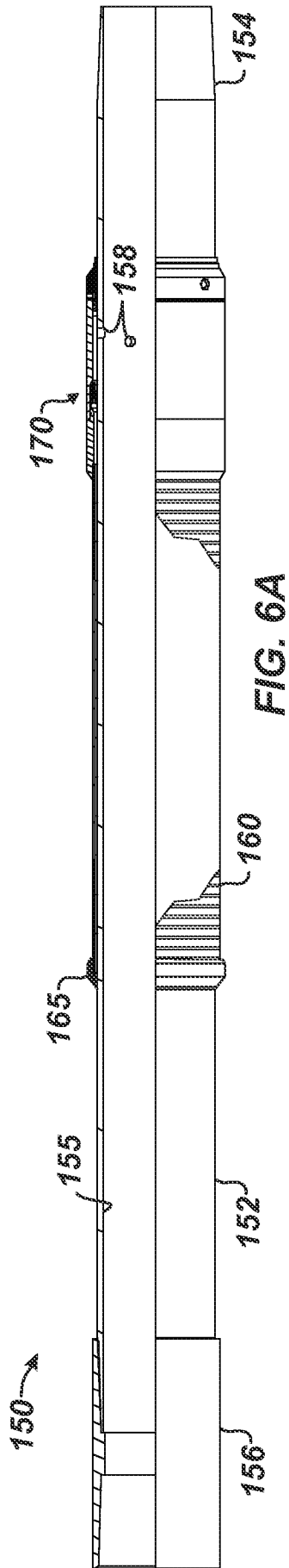

FIG. 6A

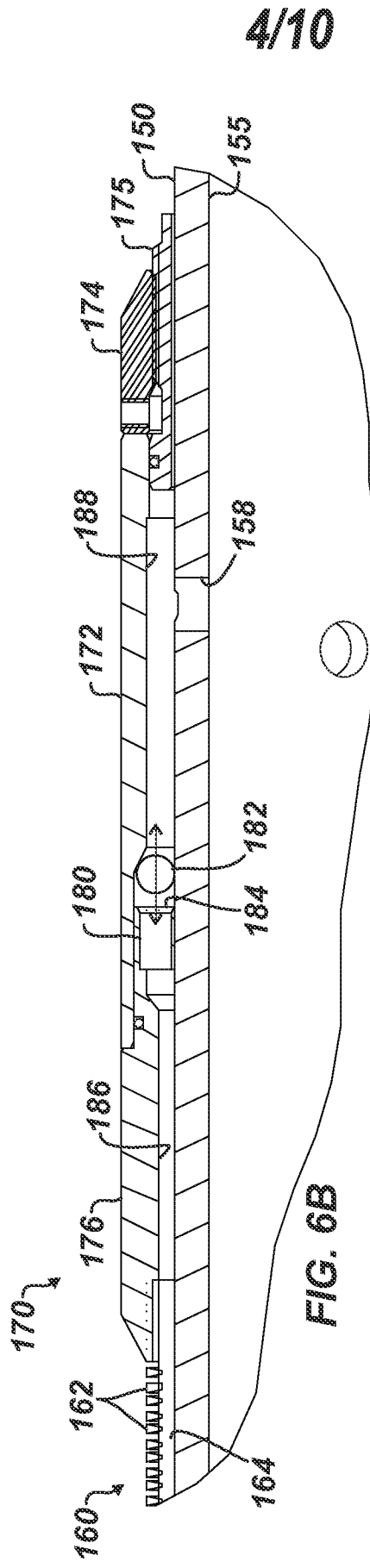

FIG. 6B

4/10

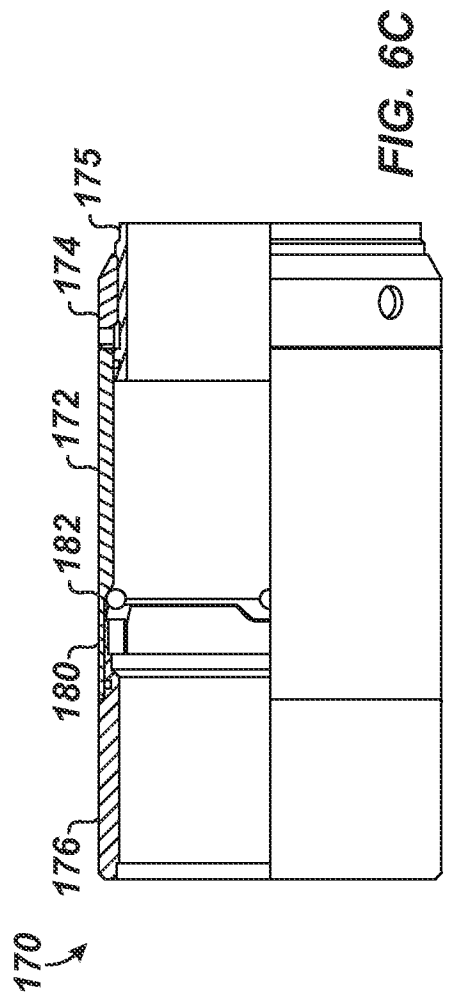
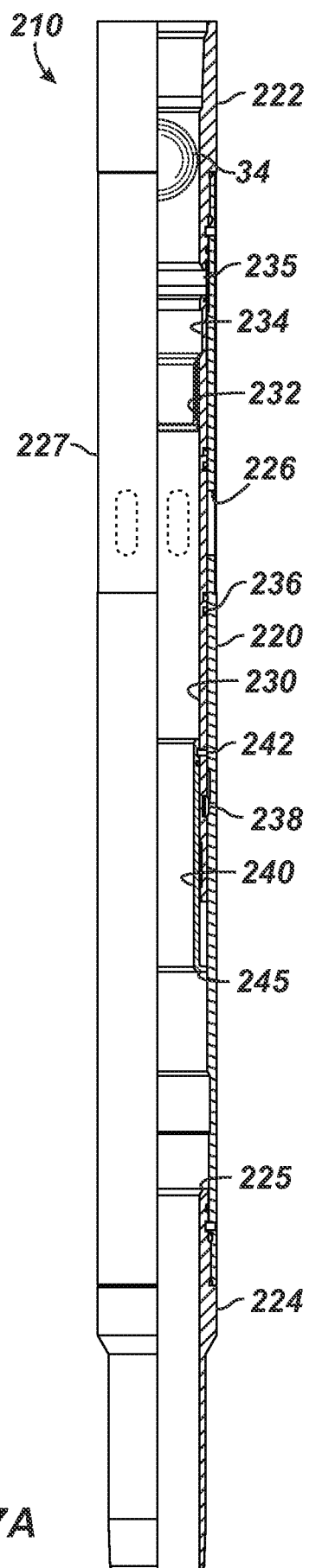

FIG. 6C

4

⊕



5/10

10

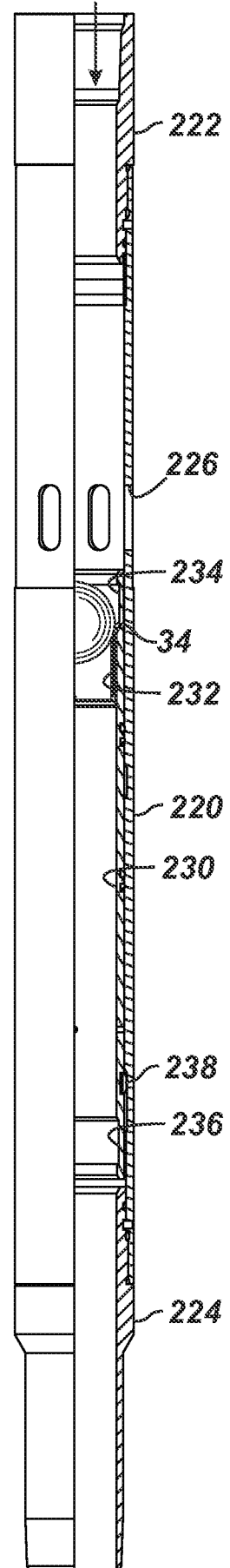

FIG. 7A

FIG. 7B

⊕

⊕

6/10

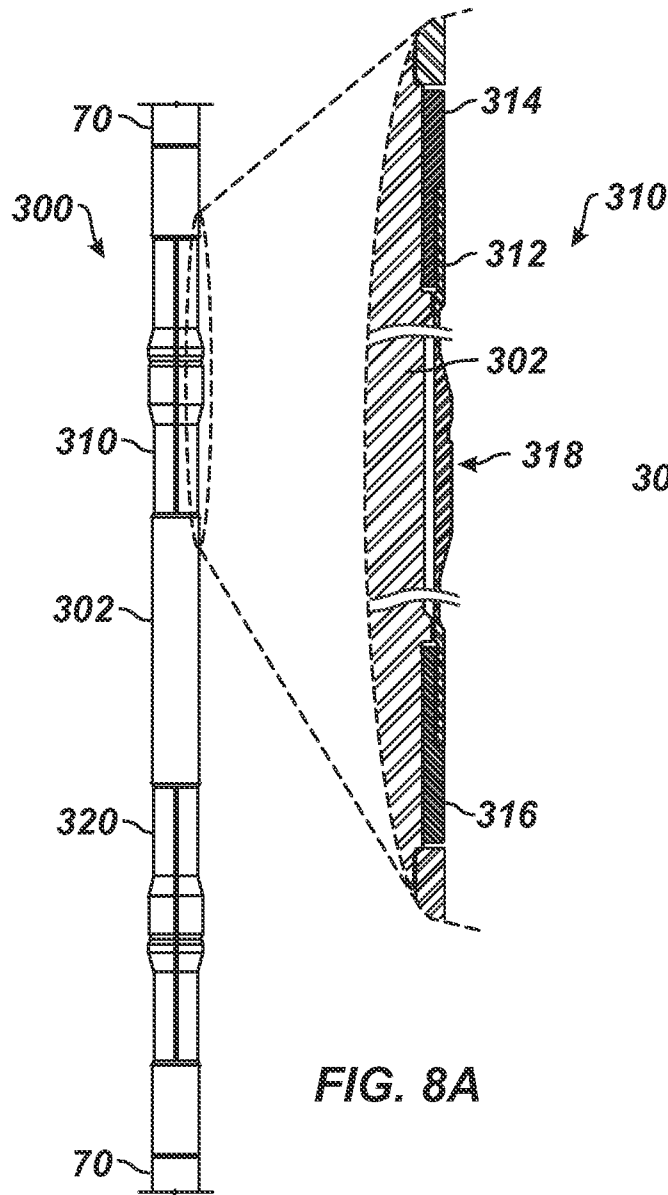

FIG. 8A

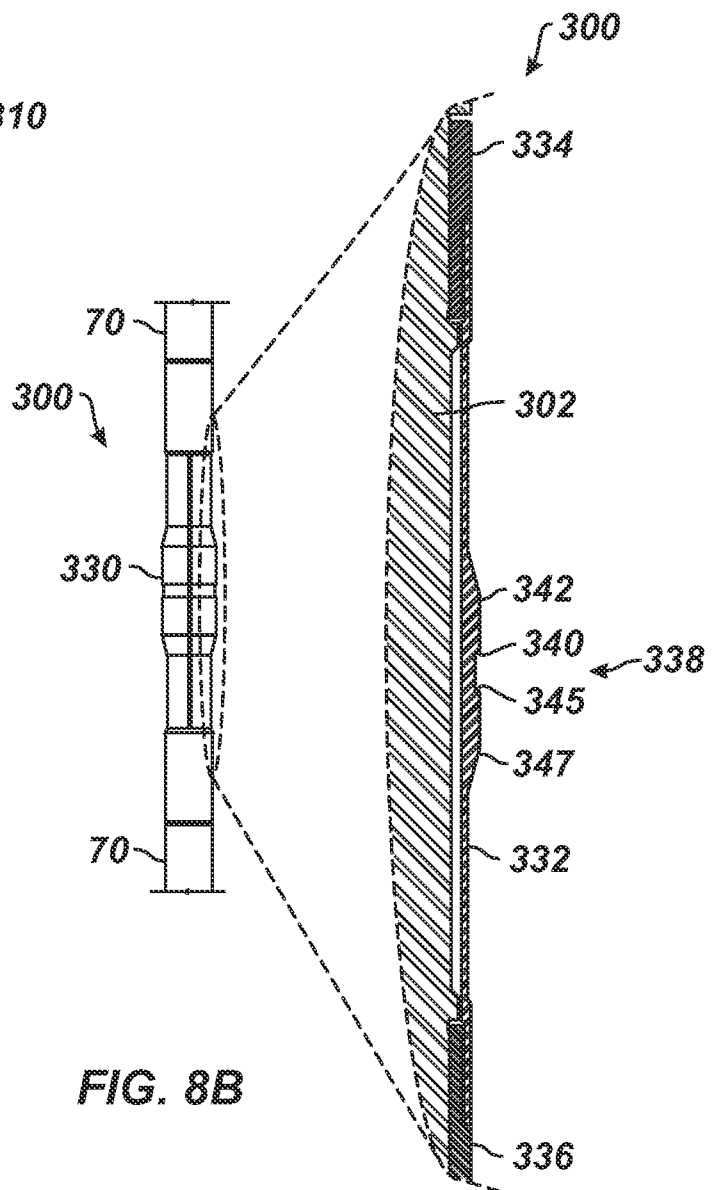
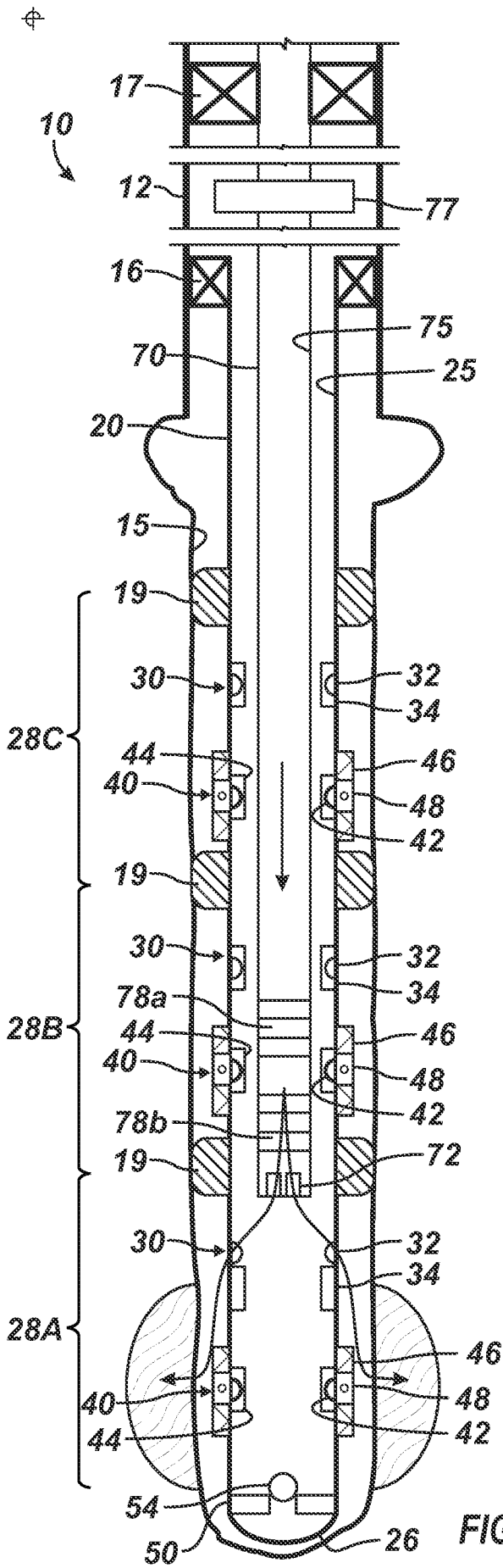
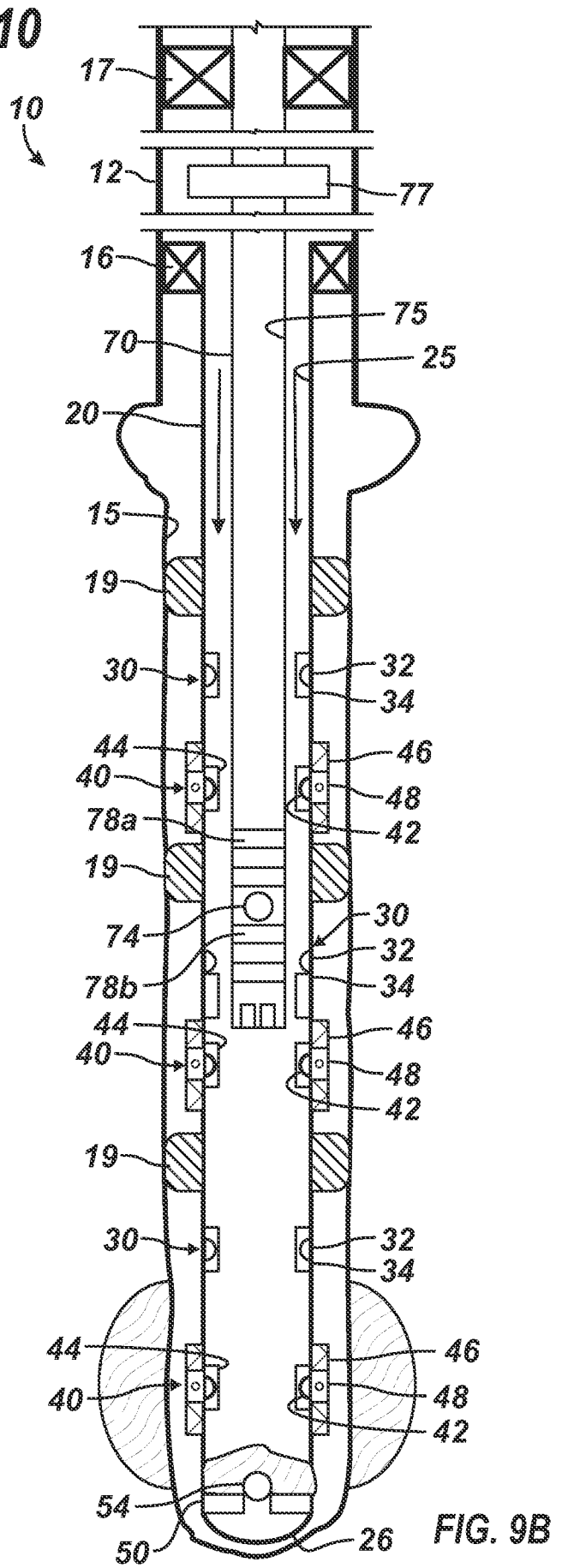

FIG. 8B

⊕



7/10



⊕

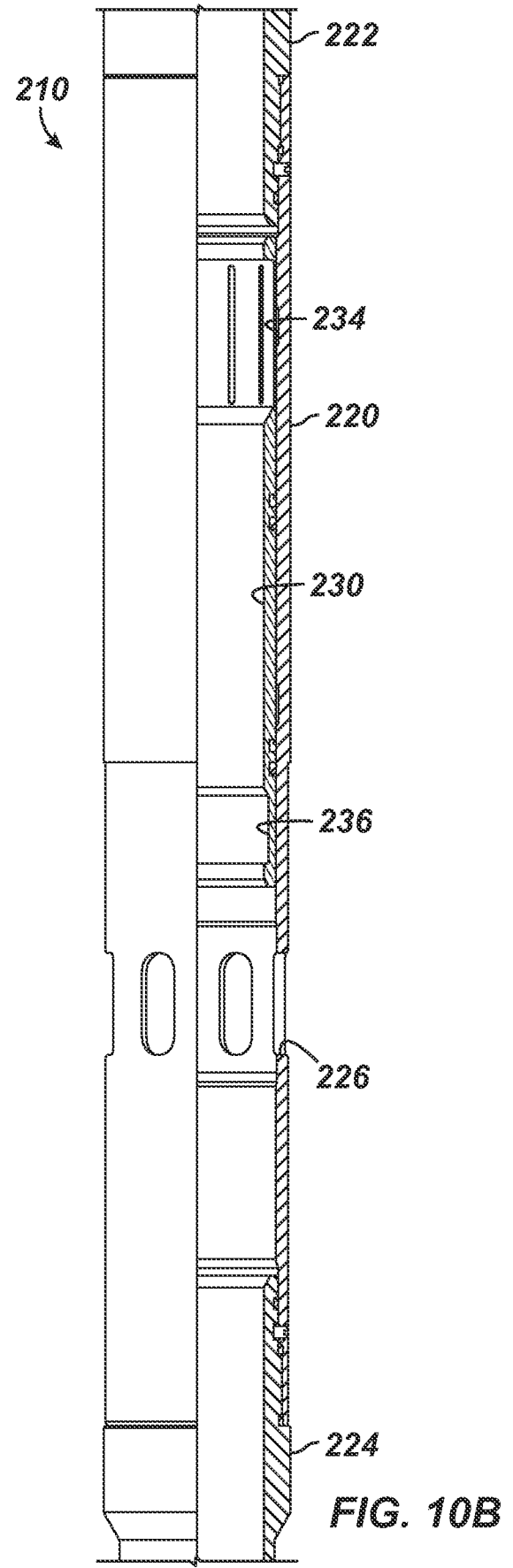
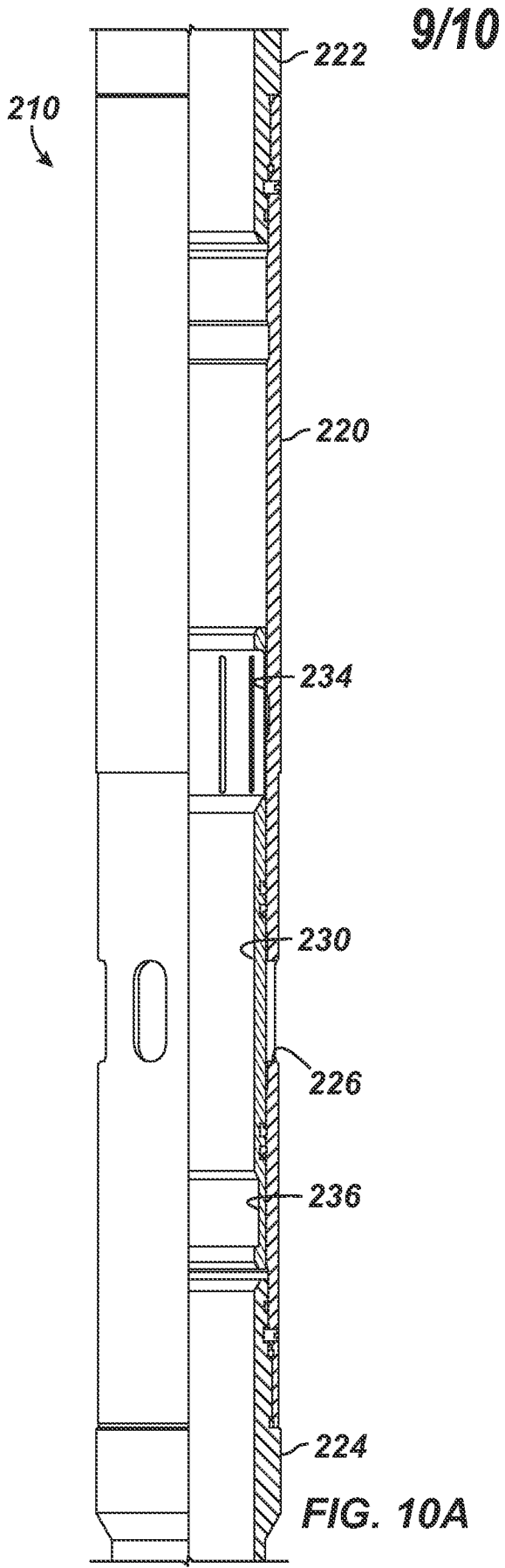

⊕

⊕

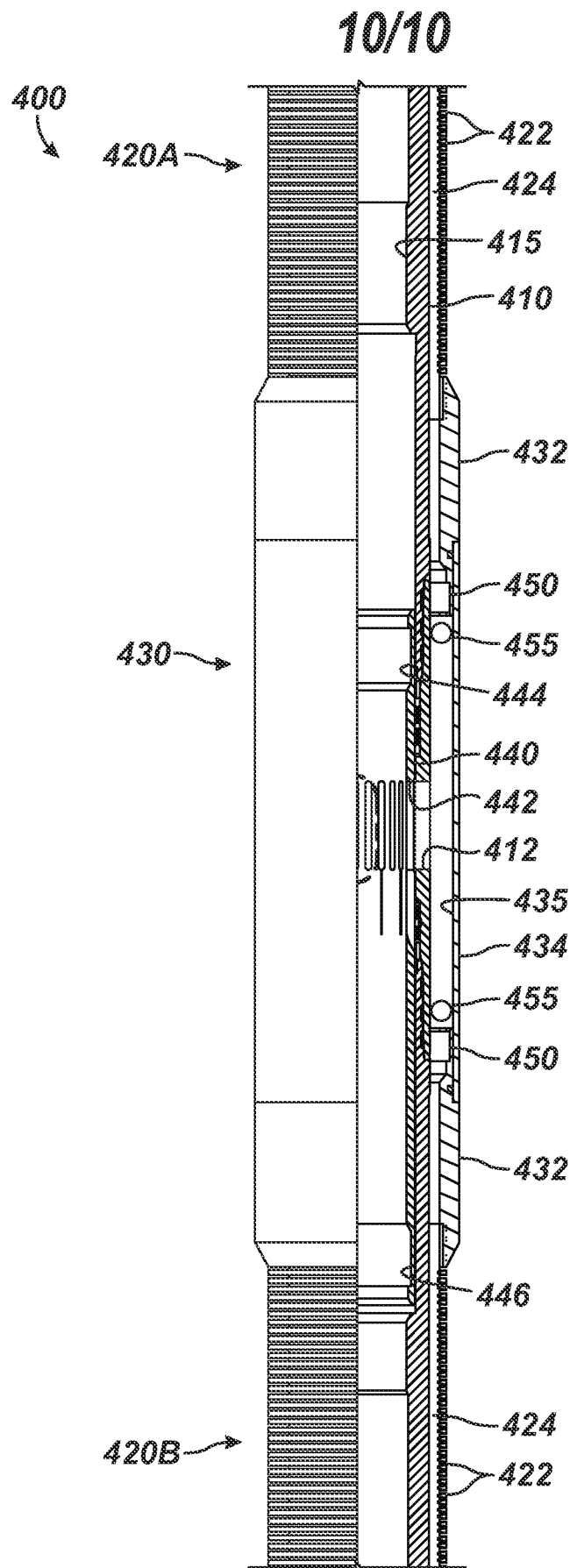

FIG. 11

⊕