

(No Model.)

E. F. BEUGLER.

GUIDE BAR FOR PLANING MACHINES.

No. 412,452.

Patented Oct. 8, 1889.

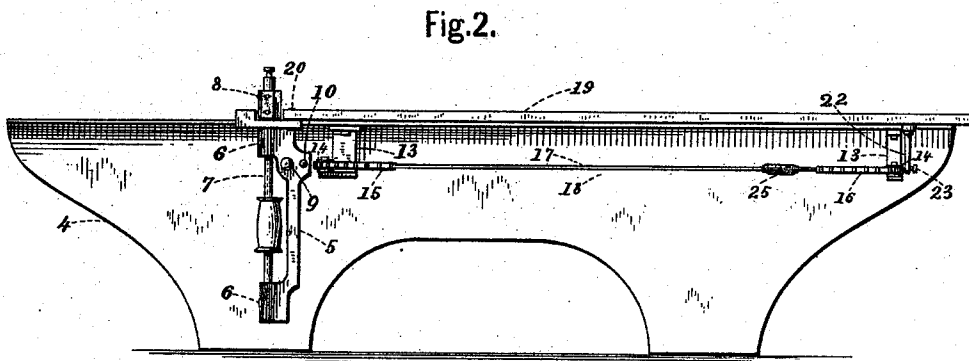
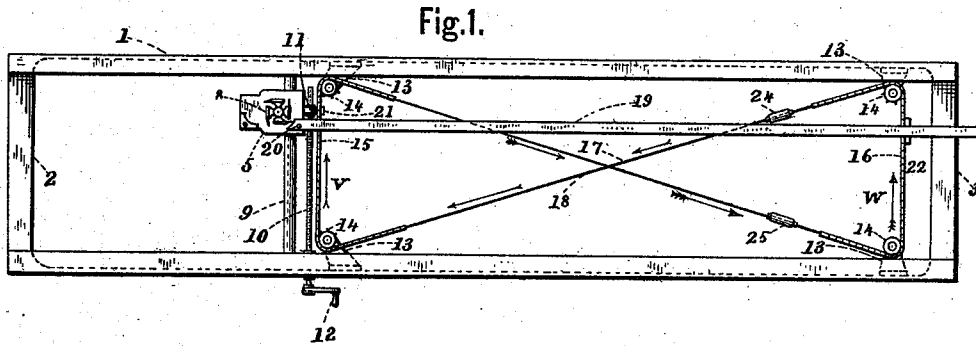

Witnesses.

*Harriet Johnson*  
*Geo. E. Crosby*

*Edwin F. Beugler, Inventor.*

*By James Sangster,*  
*Attorney.*

# UNITED STATES PATENT OFFICE.

EDWIN F. BEUGLER, OF BUFFALO, NEW YORK, ASSIGNOR TO E. & B. HOLMES, OF SAME PLACE.

## GUIDE-BAR FOR PLANING-MACHINES.

SPECIFICATION forming part of Letters Patent No. 412,452, dated October 8, 1889.

Application filed June 12, 1888. Serial No. 276,853. (No model.)

### *To all whom it may concern:*

Be it known that I, EDWIN F. BEUGLER, a citizen of the United States, residing in Buffalo, in the county of Erie and State of New York, have invented certain new and useful Improvements in Guide-Bars for Planing-Machines, of which the following is a specification.

My invention relates to adjustable or movable guide-bars for wood-planing machines, whereby the guide-bar may be easily adjusted for boards of different widths or to different portions of the width of the bed, so as to cause an even wearing of the same, and whereby the guide-bar may be adjusted to an angular position on the bed, all of which will be fully and clearly hereinafter described and claimed, reference being had to the accompanying drawings, in which—

Figure 1 is a top plan view showing only so much of a planing-machine as is required to illustrate my invention. Fig. 2 is a side elevation of the same, showing also the further side of the frame of a wood-planing machine to which it is attached.

In said drawings, 1 represents the top portion of the frame of an ordinary planing-machine.

2 and 3 represent the ends of the same, and 4 one of the sides.

The hanging cutter-head frame 5 (see Fig. 2) is made in the usual way and is provided with bearings 6, in which the cutter-head spindle 7 is mounted and carries the cutter-head 8. To the frame is secured a guide-bar 9, which passes through the cutter-head frame and supports it while permitting it to be moved back and forth across the frame by means of the screw-bar 10, which passes through the side of the machine and is secured in the usual way, so as to turn without moving longitudinally, and the screw portion then passes through a portion 11, projecting from the top of the cutter-head frame. The screw-bar 10 is operated by the crank-handle 12; but as all this portion of the device is old and well known a further description here is not required.

To the sides of the machine-frame are secured by bolts four brackets or supporting-arms 13, upon which are mounted on pins, so

as to turn easily, four rollers or sprocket-wheels 14, around which are secured the chain belts 15 16, having their ends secured to the rods 17 18, which cross each, as shown in Fig. 1.

19 represents the longitudinal guide-bar, having one end rigidly secured to the top of the cutter-head frame by means of a bolt 20 and to the chain belt 15 by a bolt 21, and its opposite end is secured to the chain belt 16 by the downwardly-projecting arm 22 and the bolt 23.

The rods 17 18 are divided so as to require the two turn-buckles 24 25, having the usual right and left hand screws, by which the rods may be tightened or loosened, as desired. By this construction it will be seen that if the cutter-head or its equivalent is moved by turning the said bar 10 in the direction of the arrow *v* it will cause that portion of the chain belt 15 parallel with the arrow *v* to move in the same direction, and the whole being connected together with the rods or cables 17 and 18, and being crossed, as shown, that portion of the chain belt 16 that is parallel with the arrow *w* will also move in the same direction. Consequently both ends of the guide-bar 19 will be moved at the same time and in the same direction by operating the handle 12 in either direction.

When it is desired to place the guide-bar 19 in an angular position, all that is required is to loosen one of the turn-buckles and draw up with the other until the desired position of the guide-bar is obtained.

I claim as my invention—

In a planing-machine, the combination, with the cutter-head, the screw for actuating the same, and a guide-bar extending longitudinally of the machine-frame, of an actuating-belt for the guide-bar running over pulleys at the sides of the machine and crossed centrally between the pulleys, and a guide-bar connected at one end to one strand of the belt and at the opposite end to the cutter-head, substantially as and for the purposes described.

EDWIN F. BEUGLER.

Witnesses:

LUKE FISHER,  
JAMES SANGSTER.