

(19) World Intellectual Property  
Organization  
International Bureau



(43) International Publication Date  
10 September 2004 (10.09.2004)

PCT

(10) International Publication Number  
**WO 2004/076078 A1**

(51) International Patent Classification<sup>7</sup>: **B05C 17/005**,  
B65D 77/18, 83/00

(21) International Application Number:  
PCT/GB2004/000850

(22) International Filing Date: 26 February 2004 (26.02.2004)

(25) Filing Language: English

(26) Publication Language: English

(30) Priority Data:  
0304351.0 26 February 2003 (26.02.2003) GB

(71) Applicant and

(72) Inventor: **WOOD, Bruce** [GB/GB]; 468 Clarkston Road,  
Netherlee, Glasgow G44 3QE (GB).

(74) Agents: **MACDOUGALL, Donald, Carmichael** et al.;  
Cruikshank & Fairweather, 19 Royal Exchange Square,  
Glasgow G1 3AE (GB).

(81) Designated States (unless otherwise indicated, for every  
kind of national protection available): AE, AG, AL, AM,

AT, AU, AZ, BA, BB, BG, BR, BW, BY, BZ, CA, CH, CN,  
CO, CR, CU, CZ, DE, DK, DM, DZ, EC, EE, EG, ES, FI,  
GB, GD, GE, GH, GM, HR, HU, ID, IL, IN, IS, JP, KE,  
KG, KP, KR, KZ, LC, LK, LR, LS, LT, LU, LV, MA, MD,  
MG, MK, MN, MW, MX, MZ, NA, NI, NO, NZ, OM, PG,  
PH, PL, PT, RO, RU, SC, SD, SE, SG, SK, SL, SY, TJ, TM,  
TN, TR, TT, TZ, UA, UG, US, UZ, VC, VN, YU, ZA, ZM,  
ZW.

(84) Designated States (unless otherwise indicated, for every  
kind of regional protection available): ARIPO (BW, GH,  
GM, KE, LS, MW, MZ, SD, SL, SZ, TZ, UG, ZM, ZW),  
Eurasian (AM, AZ, BY, KG, KZ, MD, RU, TJ, TM), Euro-  
pean (AT, BE, BG, CH, CY, CZ, DE, DK, EE, ES, FI, FR,  
GB, GR, HU, IE, IT, LU, MC, NL, PT, RO, SE, SI, SK,  
TR), OAPI (BF, BJ, CF, CG, CI, CM, GA, GN, GQ, GW,  
ML, MR, NE, SN, TD, TG).

Published:

— with international search report

For two-letter codes and other abbreviations, refer to the "Guid-  
ance Notes on Codes and Abbreviations" appearing at the begin-  
ning of each regular issue of the PCT Gazette.

(54) Title: DISPENSING APPARATUS

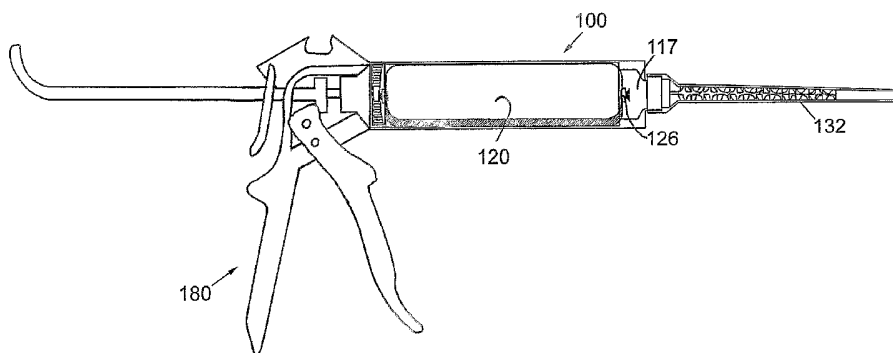

(57) Abstract: The present invention relates to an apparatus (100) for the storing and dispensing of products. In particular, the present invention relates to an apparatus (100) for the storing and dispensing of inter-reactive compounds wherein the inter-reactive compounds are efficiently mixed on extrusion or expulsion.

WO 2004/076078 A1

**DISPENSING APPARATUS****FIELD OF THE INVENTION**

5 The present invention relates to apparatus for the storing and dispensing of products. In particular, the present invention relates to apparatus for the storing and dispensing of inter-reactive compounds wherein the inter-reactive compounds are efficiently mixed on extrusion or expulsion.

10

**BACKGROUND OF THE INVENTION**

15 Dispensing apparatus in the form of cartridges is well-known in the art. In many instances, it is necessary to mix at least two different compounds together. On mixing, the compounds may react and usually harden. This type of technology is commonly used in chemical anchors, adhesives, sealants, food processing and medical applications.

20 Previous dispensing apparatus which requires the mixing of different compounds usually comprises two or more separate moulded compartments i.e. cartridges. These moulded compartments each house respective compounds which are mixed on extrusion or expulsion through an orifice. Additionally previous types of dispensing apparatus have various limitations such as significant 'tooling-up' costs in machinery for making the separate moulded cartridges. The moulded cartridges are also usually supplied in predetermined sizes meaning that different dispensing apparatus and pressure guns are required for each different size of cartridge. Moreover, 25 in these types of apparatus, usually at least two pistons are required to obtain the correct mix of different compounds, again further adding to the complexity and cost of such a device. 30

EP 0754633 relates to cartridge systems used in dispensing devices suitable for dispensing inter-reactive multi-component compositions. The system disclosed in EP 0754633 comprises a clip which is manually pulled out of a container so that a flexible cartridge containing two separated types of material extends beyond the nozzle of the dispensing device. The protruding end of the cartridge is then cut with a knife or a pair of scissors. On extruding said material, the different components are intended to be mixed. However, a number of problems exist with such a system. First of all, the clip is very difficult to pull out meaning that a pair of pliers is almost essential to pull the clip out. Furthermore, the use of a knife or scissors is dangerous to a user as a significant amount of pressure is required to cut the cartridge open. Moreover, on cutting the cartridge open, some of the material spills out which necessitates cleaning of the scissors/knife and/or cartridge end.

It is an object of at least one aspect of the present invention to obviate or mitigate at least one or more of the aforementioned problems.

It is a further object of at least one aspect of the present invention to provide dispensing apparatus which is easy to use.

It is a yet further object of at least one aspect of the present invention to provide a container for products which can then be used to dispense the product in a simple and effective manner.

A further object of at least one aspect of the present invention is to provide a container for a multi-part chemical product which allows the component parts to be kept separate for storage purposes, but then allows the component parts to be brought together when required for use.

It is a yet further object of at least one aspect of the present invention to provide apparatus for storing products which can also be used for accurate dispensing of the products when required.

5

#### SUMMARY OF THE INVENTION

According to a first aspect of the present invention there is provided apparatus for storing and dispensing a product, the apparatus comprising:

10

a cartridge; and

a substantially rigid outer casing;

15

wherein the substantially rigid outer casing is adapted to receive the cartridge and the cartridge comprises a weakened area capable of rupturing when pressure is applied to the cartridge.

On rupturing of the weakened area, the total content(s) of the cartridge is (are) dispensed.

20

The cartridge may be 'sausage-like' in shape and may be formed in any suitable extrusion apparatus such as an adapted edible sausage making apparatus.

25

The cartridge may be made from thin, flexible film with a high tear strength. The cartridge may be made from any suitable plastics material such as polyethylene. Alternatively, the cartridge may be made from a metal/alloy foil.

Typically, the material forming the cartridge is not too elastic. If the material is too elastic, the apparatus will not function properly.

30

The material forming the cartridge may also be chosen so that it does not react and/or deteriorate on contact with the contained compounds.

Typically, the cartridge may comprise a plurality of separate chambers and, in particular, at least two chambers. The different chambers may contain different

compounds which are intended to be mixed. The chambers may be of different volumes and may therefore contain different amounts of the different compounds. For example, the volume in a first chamber may be 40% of the whole cartridge and the second chamber may be 60% of the whole cartridge; the volume in the first chamber may be 20% of the whole cartridge and the volume in the second chamber may be 80% of the whole cartridge; and the volume in the first chamber may be 10% of the whole cartridge and the volume in the second chamber may be 90% of the whole cartridge.

Conveniently, on initial formation, the cartridge may have two open ends. Once the compound or compounds are extruded into the chamber or separate chambers of the cartridge, the ends of the cartridge may be sealed with any suitable sealing means. The seal for the end of the cartridge which is intended to rupture may be made weaker than a seal at the other end of the cartridge. The sealing means may comprise a sealing clip which may be releasable under pressure. Alternatively, any other suitable sealing means such as crimping, gluing, heat sealing or any form of cap or tie may also be used.

Preferably, on release of the sealing means different contents of the cartridge may mix substantially simultaneously together. This occurs as the single sealing means, seals all the contents of the cartridge. The mixing may occur immediately meaning that an efficient mix may be obtained.

Preferably, the substantially rigid outer casing may be a hollow cylindrical member made from any suitable plastics, metal or alloy material. The outer casing may have an inner cylindrical section which may be of constant diameter from one end to the other.

Alternatively, the cylindrical member at one end may have a reduced diameter.

Typically, the outer casing is adapted to receive the cartridge and form a snug fit with the outer walls of the cartridge. The distance between the outer casing and the cartridge may be about 1 - 10 mm or preferably about 5 mm. This may prevent radial expansion (i.e. widening) on application of pressure to an end of the cartridge.

Conveniently, pressure may be applied to one end of the flexible cartridge by any suitable means such as any type of dispensing gun. The pressure may be applied manually or via a pneumatic piston. Typically, the dispensing gun may be a standard mastic gun as found in many DIY stores. Alternatively, any type of syringe like plunger or screw like plunger may be used.

Conveniently, there may be an expansion chamber into which the cartridge may partially expand into. The apparatus may be adapted so that on application of pressure to one end of the cartridge, expansion in the axial direction is prevented so that at the opposite end to which the pressure is applied, the cartridge deforms into an initial bulbous conformation.

Preferably, the outer casing comprises integral reaction shoulders which abut and prevent the cartridge from moving further along the longitudinal length of the outer casing as pressure is applied. The reaction shoulders may be adapted to the shape of the cartridge and may be substantially concave. The actual surface contact area between the reaction shoulder and the cartridge may be specifically chosen. If there is too much surface contact between the reaction shoulder and the cartridge, too much pressure will need to be applied to remove the sealing means from the cartridge and the material forming the cartridge may rupture at any

specific point meaning that different compounds in different chambers may not mix. Alternatively, if there is too little surface contact between the reaction shoulders and the cartridge, the cartridge will be pushed through the outer casing without the sealing means rupturing.

In an alternative embodiment, the reaction shoulder may be formed from a separate insert which may be inserted into the outer casing. In a yet further alternative, the cartridge may be glued to the side of the outer casing thereby preventing movement along the length of the outer casing.

Typically, the expansion chamber may be integrally formed in the outer casing during initial moulding. Alternatively, the expansion chamber may be formed by a separate adaptor unit which may be placed into the outer casing. In a further alternative, the expansion chamber may be contained within a separate nozzle member.

Conveniently, the apparatus comprises a nozzle member which may be fitted to an end of the outer casing via, for example, a screw thread. The nozzle may comprise an integral mixer unit which further aids the mixing of the different products in the flexible cartridge. Alternatively, the mixer unit may be a separate item and may be inserted into the nozzle. Preferably, the diameter of the nozzle is wide enough to prevent blockage on release of the sealing means.

The nozzle may also comprise means for catching the sealing means such as a cross-member. The cross-member may be attached to the mixer unit or may be integrally formed at the entrance to the nozzle.

Preferably, the sealing means may be formed from any metal or plastics material such as soft aluminium or steel wire which is wound round the ends of the

cartridge. The sealing means is not attached too tightly or too strongly as this will prevent the release of the sealing means on application of pressure to the cartridge. It is also preferred that any sharp ends  
5 formed by the sealing means may be pointed away from the flexible cartridge thereby preventing any possible piercing of the cartridge.

An advantage of the apparatus is that once the contents of the cartridge are emptied, the emptied  
10 cartridge may be removed and replaced with a new cartridge. The apparatus may therefore be reusable. The emptied cartridge may be removed by simply detaching the pressure gun from the cartridge. To facilitate the removal of the emptied cartridge, the outer casing may  
15 have a hinged opening to allow a user easy entry.

Preferably, the film forming the cartridge is adapted so that on expansion into the expansion chamber, the film extends part way into the expansion chamber. This may prevent mixing of different compounds and may  
20 therefore prevent any hardening of mixed materials within the apparatus. This may allow the apparatus to be used at a later date without completely emptying the contents of the cartridge.

Typically, the apparatus may be used to provide  
25 dispensed products for use in chemical anchors, sealants, food processing and medical applications. Uses of chemical anchors includes securing bolts in concrete/masonry, forming a stud socket and post-installed rebar connections.

30 Compounds which are intended to be mixed may include any suitable resins, epoxies, polyesters and vinyl esters.

According to a second aspect of the present invention, there is provided a method for dispensing a product, the method comprising:

5 inserting a cartridge which comprises a weakened area into a substantially rigid outer casing which is adapted to receive the cartridge; and

applying pressure to the cartridge thereby increasing the pressure within the cartridge to a point where said weakened area ruptures enabling the contents  
10 of the cartridge to be dispensed.

Typically, the cartridge comprises a plurality of chambers containing different compounds.

Preferably, on rupturing of the weakened area, different compounds in the cartridge may be  
15 simultaneously mixed.

According to a third aspect of the present invention, there is provided a kit comprising:

a cartridge comprising at least one weakened area capable of rupturing on application of pressure to the  
20 cartridge;

a substantially rigid outer casing which is adapted to receive the cartridge; and

a dispensing gun.

Preferably, the dispensing gun is a standard mastic  
25 gun.

Preferably, the kit may be used to simultaneously mix different compounds.

According to a fourth aspect of the present invention there is provided a cartridge which comprises  
30 at least one weakened area capable of rupturing when pressure is applied to the cartridge and wherein the cartridge comprises at least two separate chambers containing different materials which are dispensable on application of pressure.

Typically, on rupturing of the weakened area the materials in the separate chambers may simultaneously mix with one another.

Conveniently, the cartridge is made from thin,  
5 flexible film with a high tear strength.

Typically, the cartridge is 'sausage-like' in shape.

According to a fifth aspect of the present invention, there is provided use of a kit according to the fourth aspect for dispensing a product.

10 According to a sixth aspect of the present invention, there is provided apparatus for storing and distributing a product, comprising a container which has at least one weakened area that will rupture when pressure is applied to the container.

15

#### **BRIEF DESCRIPTION OF THE DRAWINGS**

Embodiments of the present invention will now be described, by way of example only, with reference to the accompanying drawings in which:

20 Figures 1A, 1B and 1C are schematic representations of dispensing apparatus according to a first embodiment of the present invention;

Figures 2A - 2E are schematic representations of the operation of dispensing apparatus according to a second  
25 embodiment of the present invention;

Figures 3A - 3C are schematic representations of dispensing apparatus according to a third embodiment of the present invention;

Figures 4A and 4B are schematic representations of  
30 dispensing apparatus according to a fourth embodiment of the present invention;

Figures 5A and 5B are schematic representations of dispensing apparatus according to a fifth embodiment of the present invention;

10

Figures 6A and 6B are schematic representations of dispensing apparatus according to a sixth embodiment of the present invention;

Figures 7A and 7B are schematic representations of a  
5 mixing element according to an embodiment of the present invention;

Figures 8A and 8B are schematic representations of a further mixing element according to an embodiment of the present invention;

10 Figures 9A - 9C are schematic representations of different casings according to the present invention; and

Figure 10 is a schematic representation of the length of film extending beyond a clip.

15 **DETAILED DESCRIPTION**

Referring to Figures 1A and 1B, there are schematic representations of dispensing apparatus, generally designated 100. The apparatus 100 comprises a substantially rigid cylindrical hollow casing 102. The  
20 inner surface 104 of the casing 102 has a substantially tubular section which forms a wide opening 106 at a first end of the casing 102 and a narrower opening 108 at a second end of the casing 102. Towards the second end of the casing 102, the diameter of the inner surface 104 of  
25 the casing 102 narrows, firstly via a shoulder 110, which then extends for a period along a reduced diameter section 112. There is then a further reduction in the diameter via a chamfered surface 114 to a final reduced diameter tubular section 116. The region of the casing  
30 102 extending between the shoulder 110 and the narrow opening may be termed an expansion chamber 117. On the outer surface of tubular section 116 there is a screw thread 118. The cylindrical casing 102 is made from any suitable plastics or metal/alloy material.

As shown in Figure 1A, the cylindrical casing 102 is used to snugly receive a cartridge 120 which may be described as being 'sausage-like' in shape. The cartridge 120 comprises two separate chambers 122,124 which are secured to one another via adhesive means in the 'sausage-like' configuration. Chamber 122 contains compound A and chamber 124 contains compound B. The chambers 122,124 are sealed separate units.

The chambers 122,124 are formed from a thin material which has a limited degree of flexibility. However, the material is not too elastic otherwise the material will simply stretch on application of pressure. The material also has a high tear strength to prevent the cartridge 120 from inadvertently bursting open. The material is also specifically chosen so as to be inert towards the materials which they contain. The material may be made from any suitable plastics, polymer or metal foil material.

The ends of the cartridge 120 are closed with clips 126 once compounds A and B have been inserted into their respective chambers 122,124. Any suitable type of apparatus is used to form the 'sausage-like' cartridge 120. For example, edible sausage making apparatus may be used. Clips 126 are formed from relatively soft aluminium wire and are wound around the ends of the chambers 122,124 to prevent any leakage of compounds A and B during storage or initial placement in the casing 102. Careful attachment of the clips 126 is required so that any sharp ends formed by the clips 126 do not pierce the cartridge at any time during use of the dispensing apparatus 100.

A compressing back plate 128 is also shown in Figures 1A and 1B which has a concave surface 130 adapted to engage with the cartridge 120.

The compressing back plate 128 comprises a central recess 129 which clip 126 inserts into on engagement with the back plate 128.

5 Figures 1A and 1B also show that the apparatus comprises a mixing nozzle, generally designated 132. The mixing nozzle 132 has an opening 134. Around the opening 134 there is a thread 136 which is adapted to screw onto thread 118 on the casing 102. The mixing nozzle 132 has an integral spiral chamber 138 which aids in the mixing  
10 of compounds A and B.

Figure 1A shows that the cartridge 120 is tightly secured within the casing 102. It is important to appreciate that the sides of the cartridge 120 are close to or abut against the inside surface 104 of the casing  
15 102, therefore restricting any form of axial displacement. Furthermore, the cartridge 120 engages against shoulder 110 and prevents the cartridge 120 from travelling any further along the casing 102.

Figure 1C shows the apparatus as illustrated in  
20 Figures 1A and 1B attached to a dispensing gun 180.

Figures 2A - 2E represent a casing 202 according to a second embodiment of the present invention. Similar reference numerals to that used in Figures 1A and 1B are used but have the prefix "2". The container 202 is  
25 similar to the casing 102 in Figures 1A and 1B, apart from the fact that there is a difference in the surface 214 in the casing 102 which reduces the diameter of the inner surface 204 of the casing 102. Surface 214 reduces the diameter in a smoother concave manner, minimising any  
30 sharp edges which may pierce the cartridge 220.

Figures 2A - 2E progressively show the effect on the cartridge 220 as pressure is applied to one end. The pressure is applied by a mastic gun (not shown). In Figure 2D it is clear that the cartridge 220 comprising

separate chambers 222,224 fills expansion chamber 217 at the end of the container 202 and abuts the inner surface 204 of the casing 202. It should also be appreciated that shoulders 210 prevent the cartridge 220 from merely  
5 being pushed along the container 202. The inner surface 204 of the hollow casing 202 also prevents the cartridge 220 from merely expanding axially. On application of pressure to the cartridge 220, the unsupported end of the cartridge 220 expands into a bulbous form into expansion  
10 chamber 217 as shown in Figures 2B and 2C and eventually completely fills the expansion chamber 217, as shown in Figure 2D.

On application of further pressure, the hydrostatic pressure inside the cartridge 220 eventually forces the  
15 clip 226 off, as shown in Figure 2E.

As shown in Figure 2E, the film of the cartridge 220 extends part way along the narrowest section of the casing 202 which helps to prevent any hardening of material therein.

20 On removal of the clip 226, compounds A and B within the separate chambers 222,224 are free to be extruded on application of further pressure from a mastic gun.

Furthermore, on release of clip 226, compounds A and B are released substantially simultaneously enabling the  
25 different compounds to efficiently mix.

Figures 3A - 3C show a third embodiment of the present invention. Once again, reference signs similar to that previously used are utilised with the prefix "3". Side surfaces 314 are concave shaped to support the  
30 cartridge 320 as pressure is applied from a mastic gun. The cartridge 320 fills the expansion chamber 317 at the end of the container 302. Figure 3C shows the clip 326 being forced off due to the increased pressure, with the minimum length between a nozzle and the film being shown

which prevents hardening and blockage of compounds A and B if extrusion of the material is stopped at any time.

Figures 4A and 4B represent a fourth embodiment of the present invention. Reference signs similar to those previously used are utilised with the prefix "4". In Figure 4B, the cartridge 420 is shown within the casing 402. In this embodiment, the casing 402 simply comprises an extended tubular section 404 of uniform diameter. There is therefore no expansion chamber in the casing 402 on insertion of the cartridge 420. However, as shown in Figures 4A and 4B, the mixing nozzle 432 comprises an expansion chamber 417 via which the cartridge 420 may expand into on application of pressure to the opposite end. The container 402 has shoulders 410 which prevent the cartridge 420 from being longitudinally displaced on application of pressure. Additionally, the container 402 prevents axial displacement of the cartridge 420 on application of pressure. The cartridge 420 will therefore expand into expansion chamber 417. Eventually, as discussed previously, clip 426 will release once a specific internal hydrostatic pressure is obtained for the container 420.

Figures 5A and 5B show a fifth embodiment. Similar reference signs to those used previously are used with the prefix "5". In this embodiment, a standard cylindrical hollow casing 502 is used which has a substantially uniform internal diameter. To create an expansion chamber 517 for the cartridge 520 to expand into, an adaptor 540 is inserted into the casing 502, as shown in Figure 5A. The adaptor 540 comprises a shoulder 510 which prevents longitudinal movement of the cartridge 520. A reduced circumference section 512 and an additional surface 514 further reduces the diameter of

casing 502. The operation of the cartridge 502 generally is the same as that previously described.

Figures 6A and 6B represent dispensing apparatus, generally designated 600 which is substantially similar to that described previously. The reference numerals have the prefix "6". The difference in dispensing apparatus 600 is that there is a nozzle adaptor 650 which is attachable to the container 602. This allows a range of mixing nozzles 632 to be used enabling different flows of material to be obtained.

In the present invention, there is the potential problem that the clip used to retain the different compounds in their respective chambers may block the extrusion of the compounds. To overcome this problem, means of catching the clip may be deployed.

The embodiment shown in Figures 7A and 7B comprises a cross member 762 at one end of mixing element 760. As shown in Figure 7B, on release of the clip 726, the cross member 762 prevents the clip 726 from entering the main body of mixing nozzle 732.

Figures 8A and 8B represent a further embodiment wherein mixing nozzle 832 comprises a cross-section 862 which will once again catch a clip 826 before it enters the main body of mixing nozzle 832.

While specific embodiments of the invention have been described above, it will be appreciated that departures from the described embodiments may still fall within the scope of the invention. For example, there may be any number of different chambers and the cartridges may be of any suitable size. Additionally, any type of sealing means may be used to close the ends of the chambers. Furthermore, the sealing means may be attached relatively loosely meaning that only a minimum

16

amount of pressure needs to be applied to force the sealing means off the cartridge.

### EXAMPLES

#### 5 EXAMPLE 1

10 Figures 9A - 9C represent different lengths of film extending beyond a clip. The embodiments shown in Figures 9A and 9B will require too high a pressure to force the clip off the casing. Figure 9C represents more of a preferred embodiment with the film extending a relatively small distance beyond the clip.

15 Figure 10 defines the distance which the film extends beyond the clip by reference symbol 'A'. Table 1 below shows that the clip only comes off when the film extends 4mm or 2.5mm beyond the clip.

Table 1

Test	A (mm)	Burst Mode
1	10	Film
2	11	Film
3	11	Film
4	10.5	Film
5	8	Film
6	7.5	Film
7	6	Film
8	5	Film
9	4	Clip
10	2.5	Clip

20

CLAIMS

1. Apparatus for storing and dispensing a product, the apparatus comprising:  
5 a cartridge; and  
a substantially rigid outer casing;  
wherein the substantially rigid outer casing is adapted to receive the cartridge and the cartridge comprises a weakened area capable of rupturing when  
10 pressure is applied to the cartridge.
2. Apparatus according to claim 1, wherein the cartridge is made from thin, flexible film with a high tear strength.  
15
3. Apparatus according to claim 1, wherein the cartridge is made from a metal/alloy foil.
4. Apparatus according to any preceding claim, wherein  
20 the cartridge comprises a plurality of separate chambers wherein each separate chamber contains different compounds which are intended to be mixed.
5. Apparatus according to any preceding claim, wherein  
25 the cartridge is sealed with sealing means.
6. Apparatus according to claim 5, wherein the sealing means comprises a sealing clip which is releasable under pressure.  
30
7. Apparatus according to any of claims 5 or 6 wherein, on release of the sealing means, different contents of the cartridge mix substantially together.

8. Apparatus according to any preceding claim, wherein the outer casing is adapted to receive the cartridge and forms a snug fit with the outer walls of the cartridge.
- 5 9. Apparatus according to any preceding claim, wherein pressure is applied to one end of the cartridge by a dispensing gun.
- 10 10. Apparatus according to any preceding claim, wherein the cartridge expands into an expansion chamber.
- 15 11. Apparatus according to any preceding claim, wherein the outer casing comprises reaction shoulders which abut and prevent the cartridge from moving further along the longitudinal length of the outer casing as pressure is applied.
- 20 12. Apparatus according to any preceding claim, wherein the apparatus further comprises a nozzle.
13. Apparatus according to claim 12 wherein the nozzle comprises an integral mixer unit which further aids the mixing of different compounds.
- 25 14. Apparatus according to any of claims 12 or 13 wherein the nozzle also comprises means for catching the sealing means.
- 30 15. Apparatus according to any of claims 5 to 14 wherein the sealing means is formed by any metal or plastics material such as aluminium or steel wire which is wound round the ends of the cartridge.

16. Use of apparatus according to any preceding claim for dispensing products for use in chemical anchors, sealants, food processing and medical applications.
- 5 17. A method for dispensing a product, the method comprising:
- inserting a cartridge which comprises a weakened area into a substantially rigid outer casing which is adapted to receive the cartridge; and
- 10 applying pressure to the cartridge thereby increasing the pressure within the cartridge to a point where said weakened area ruptures enabling the contents of the cartridge to be dispensed.
- 15 18. A method according to claim 17, wherein the cartridge comprises a plurality of chambers containing different compounds.
19. A method according to any of claims 17 or 18  
20 whereupon on rupturing of the weakened area, different compounds in the cartridge are mixed.
20. A kit comprising:
- a cartridge comprising a weakened area capable of  
25 rupturing on application of pressure to the cartridge;
- a substantially rigid outer casing which is adapted to receive the cartridge; and
- a dispensing gun.
- 30 21. A kit according to claim 20, wherein the dispensing gun is a standard mastic gun.
22. A kit according to any of claims 20 or 21 wherein the kit is used to mix different compounds.

23. A cartridge which comprises at least one weakened area capable of rupturing when pressure is applied to the cartridge and wherein the cartridge comprises at least  
5 two separate chambers containing different materials which are dispensable in a mixture on application of pressure.

24. A cartridge according to claim 23 wherein the  
10 cartridge is made from thin, flexible film with a high tear strength.

25. A cartridge according to any of claims 23 or 24  
15 wherein the cartridge comprises sealing means to contain the different materials within the chambers.

20

25

30

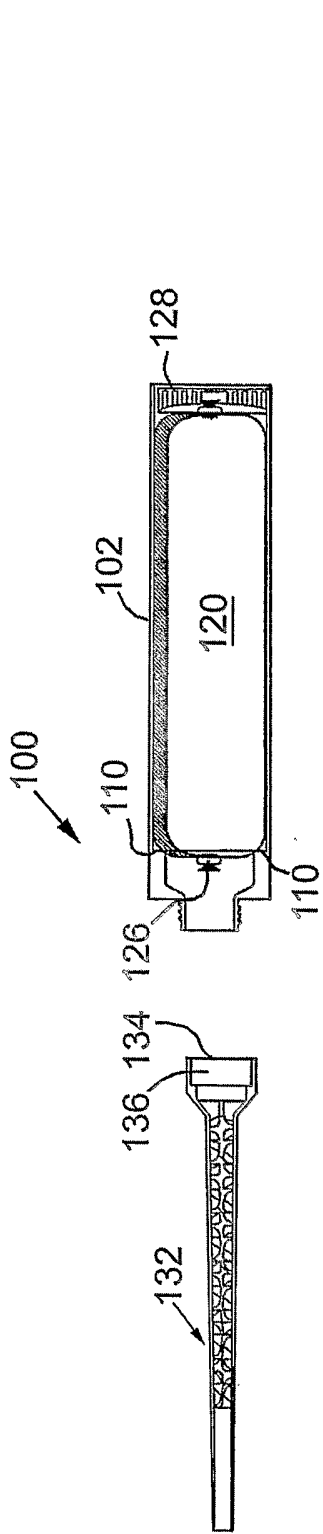

Fig. 1A

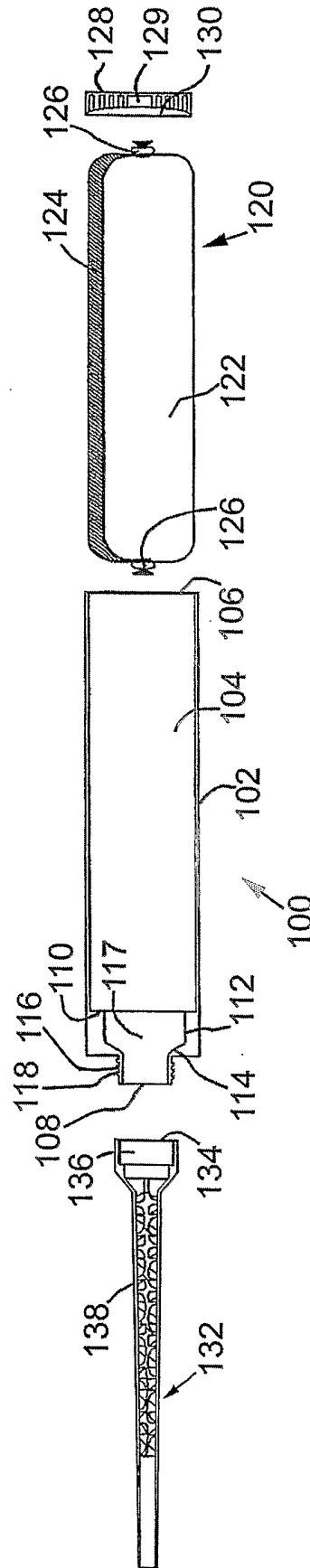

Fig. 1B

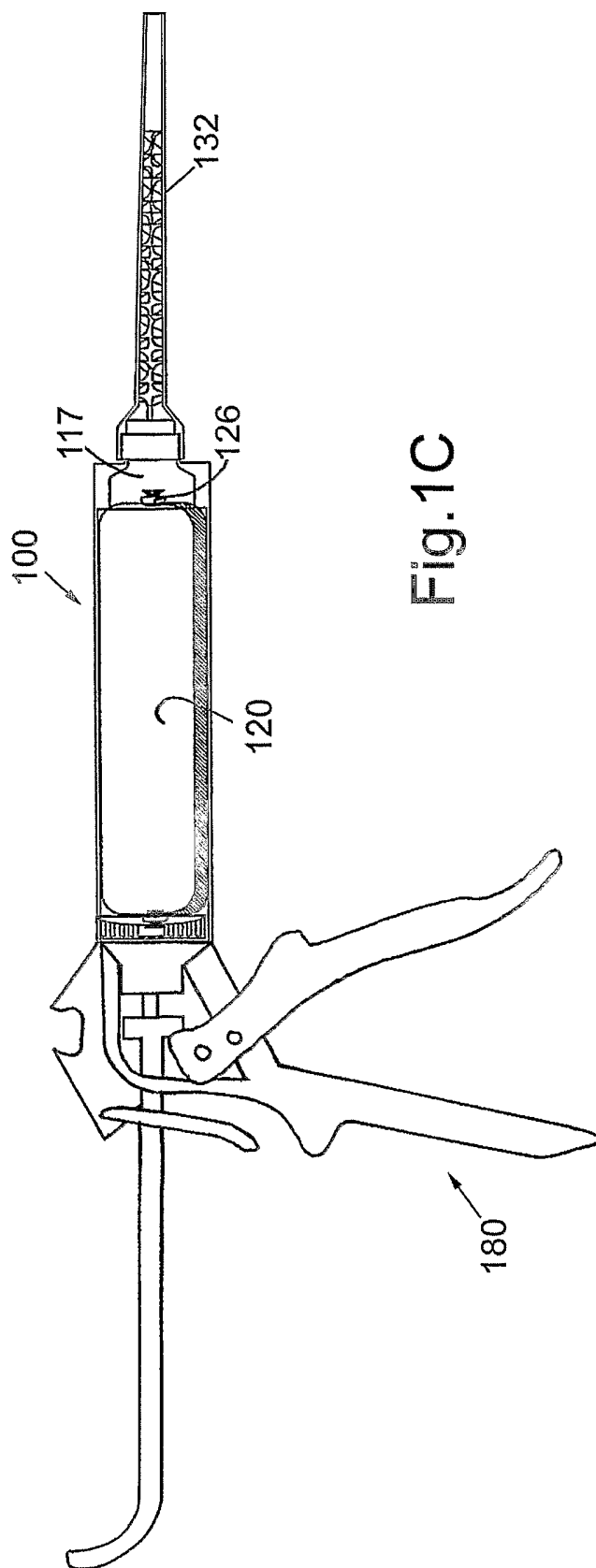

Fig.1C

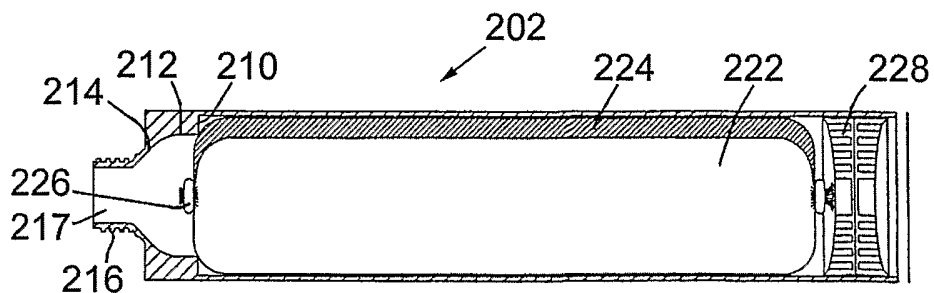

Fig.2A

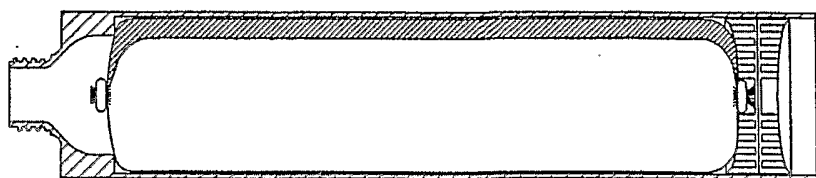

Fig.2B

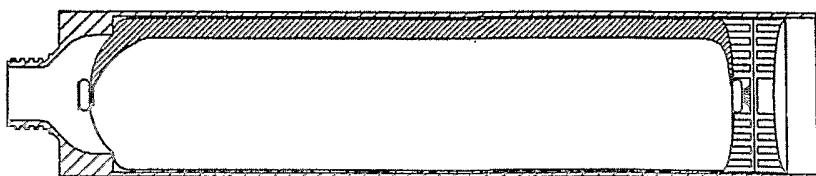

Fig.2C

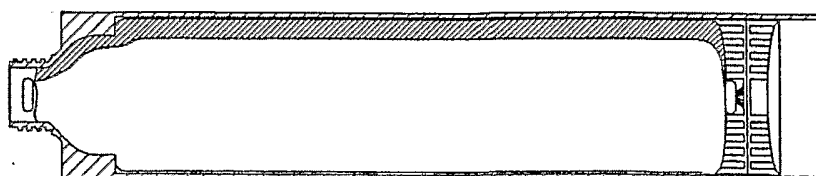

Fig.2D

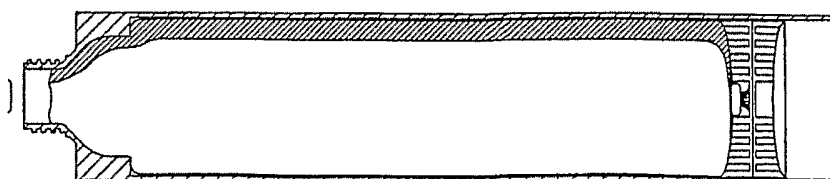
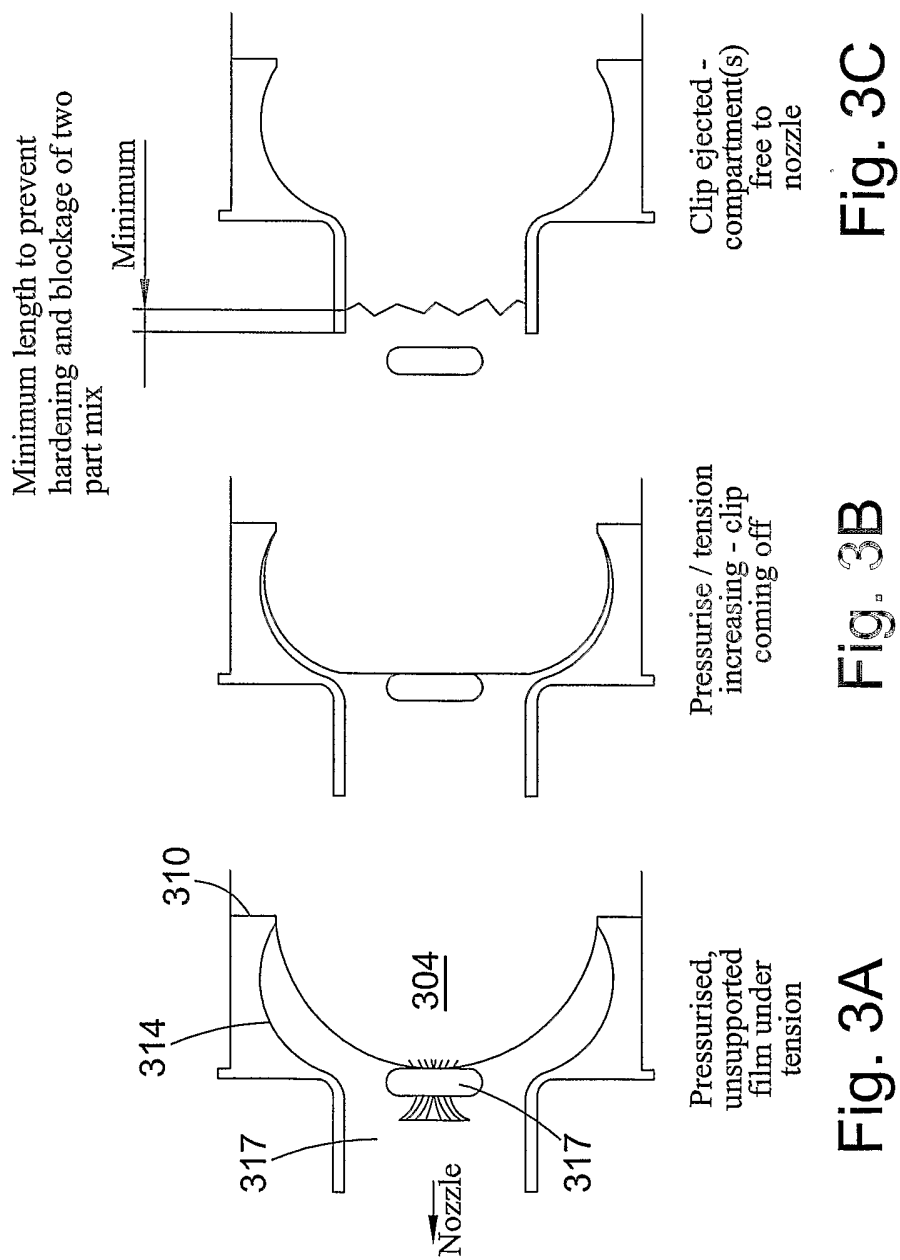

Fig.2E



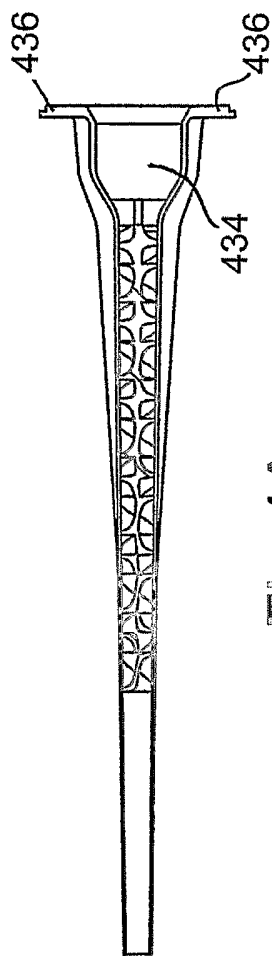

Fig. 4A

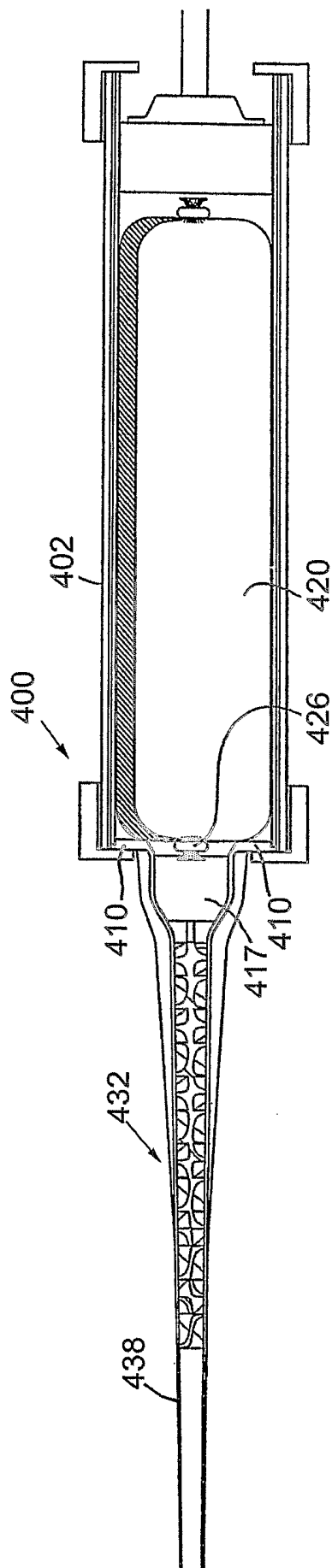

Fig. 4B

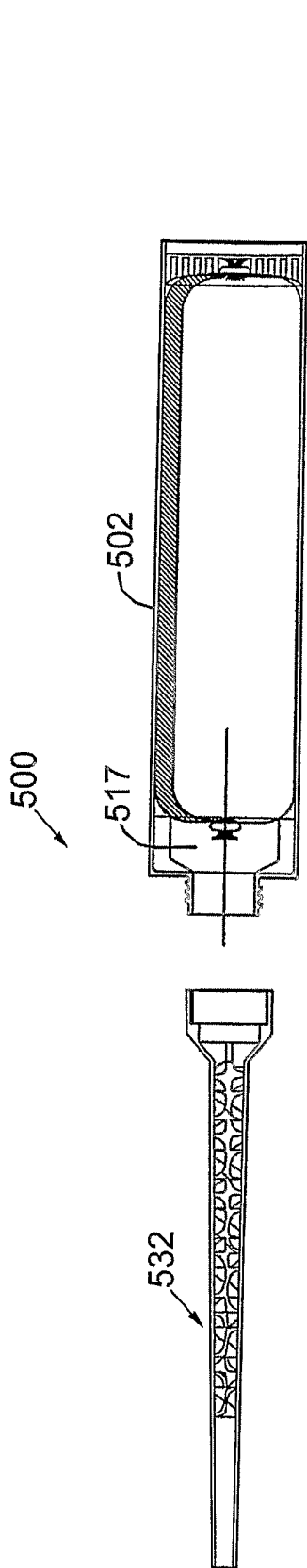

Fig. 5A

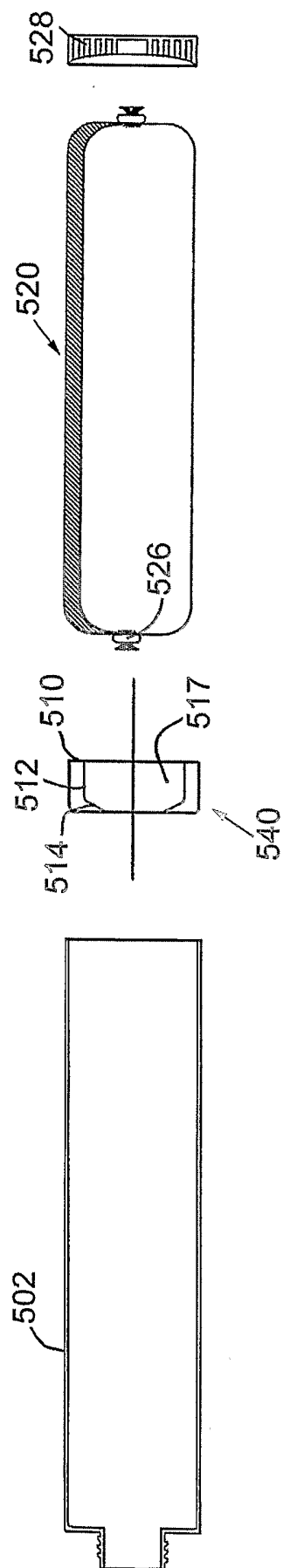

Fig. 5B

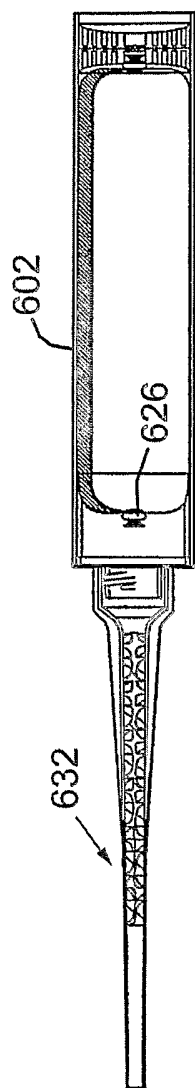

Fig. 6A

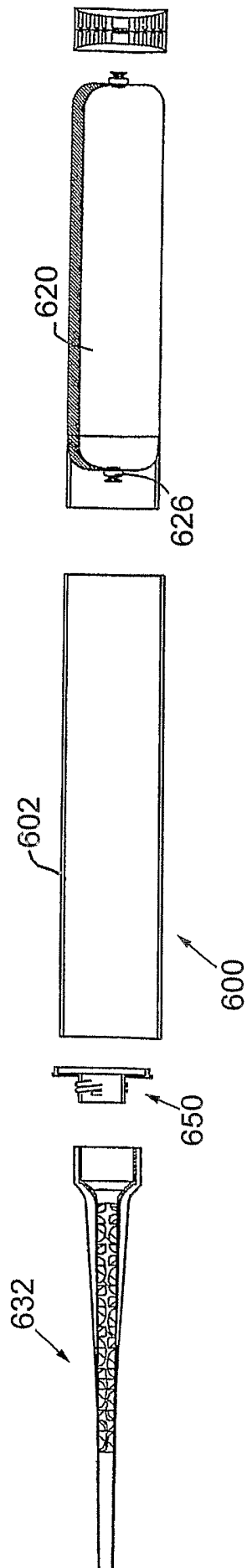

Fig. 6B

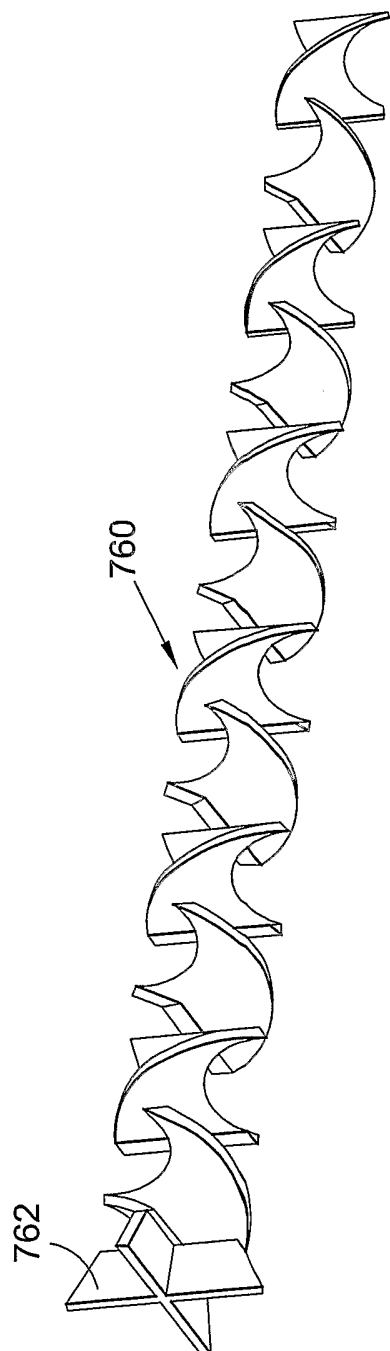

Fig. 7A

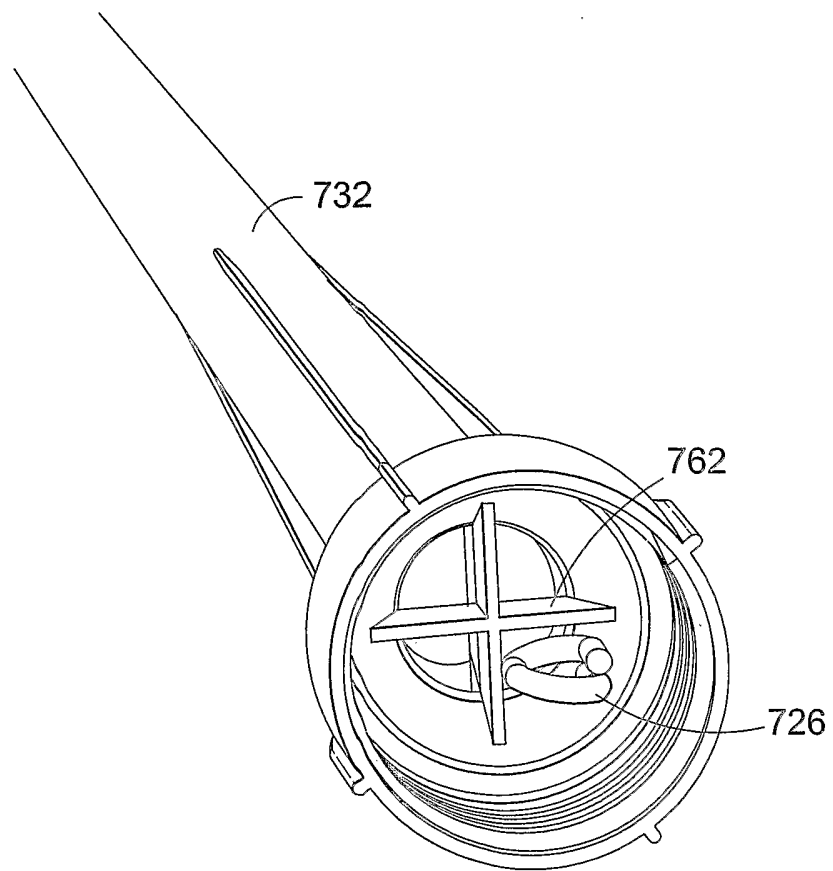

Fig. 7B

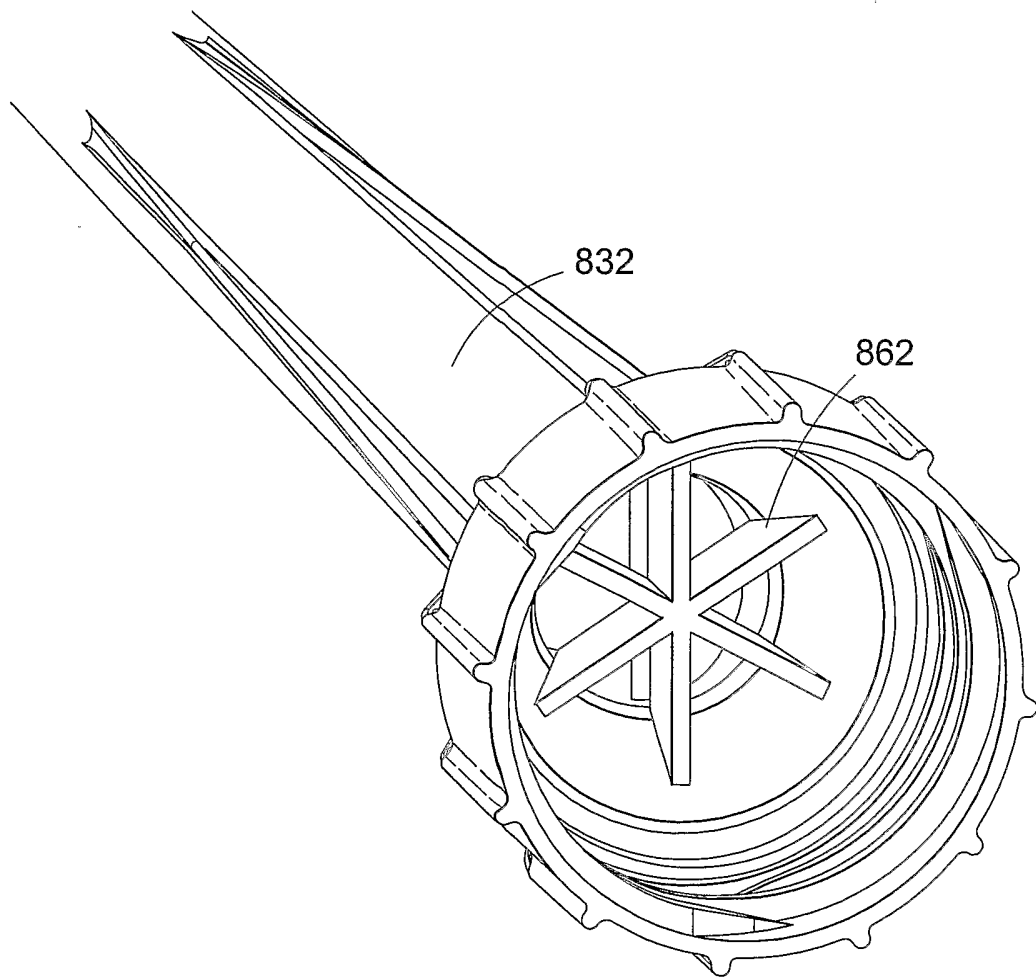

Fig.8A

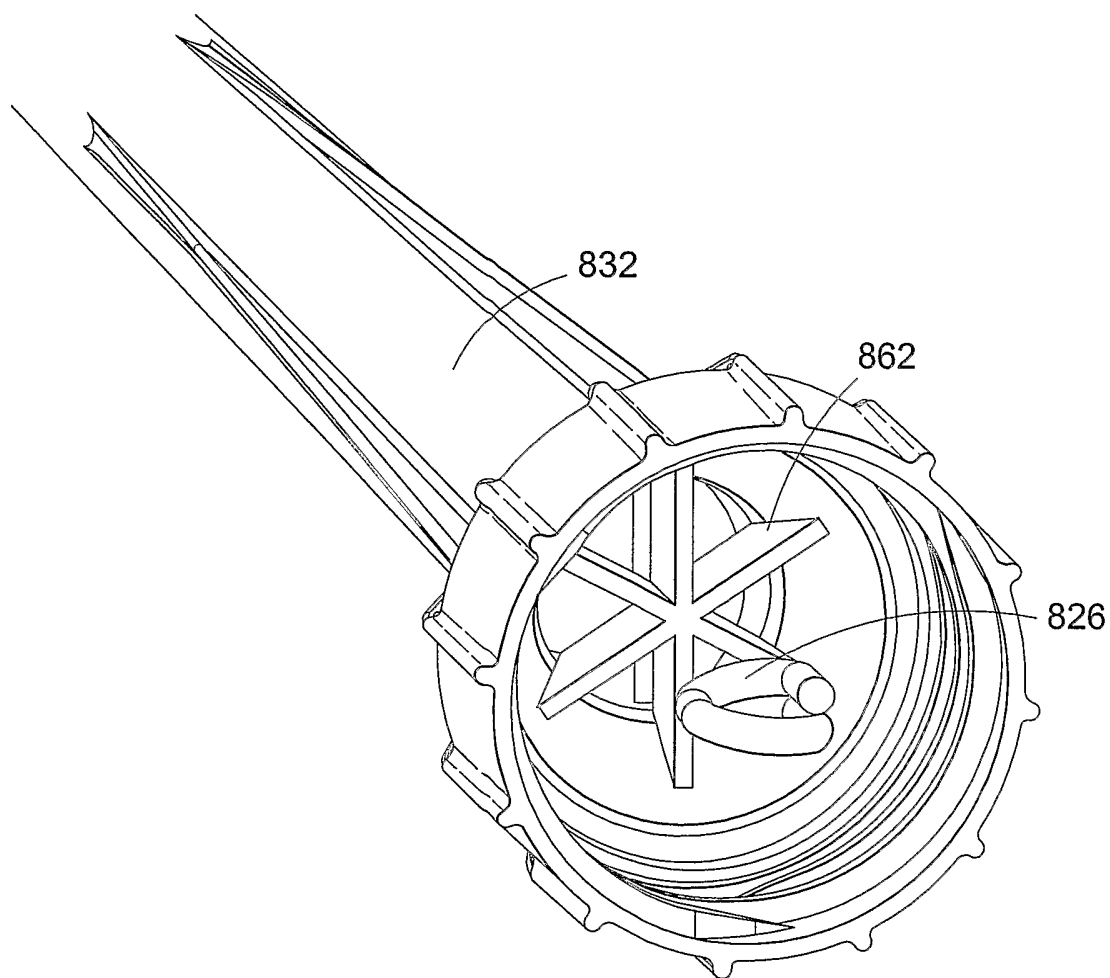

Fig.8B

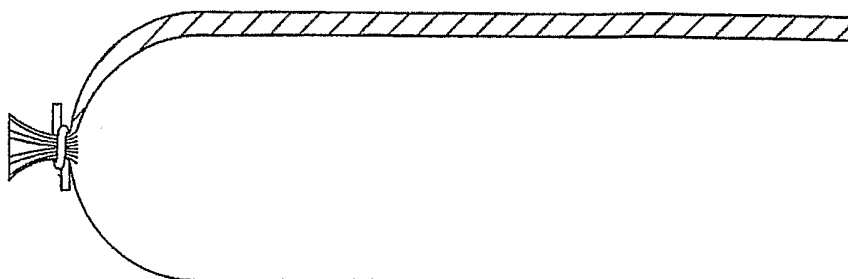

Fig.9A

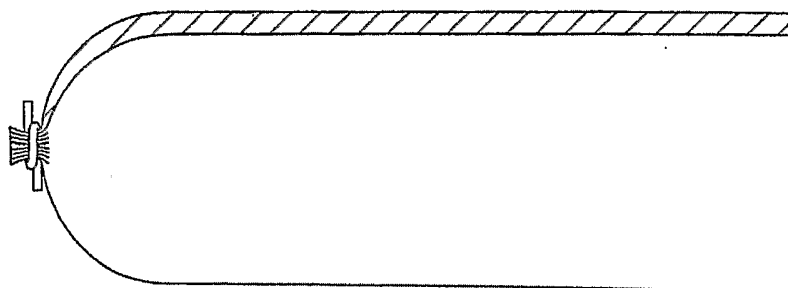

Fig.9B

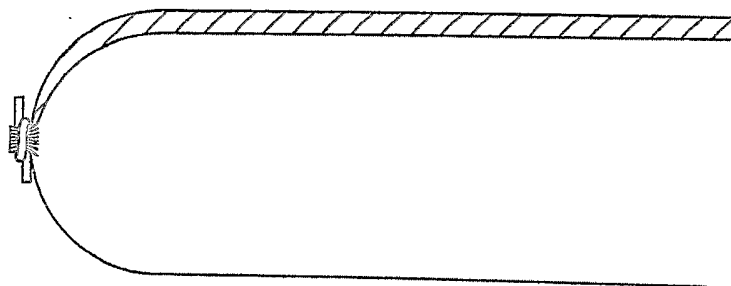

Fig.9C

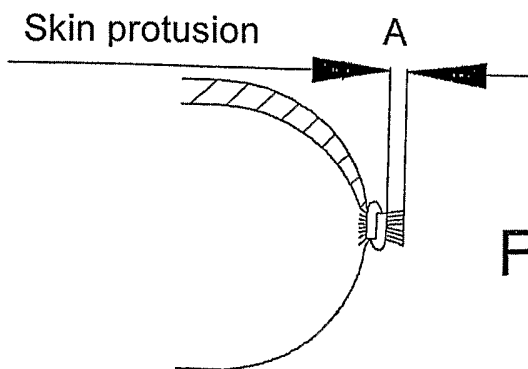

Fig.10

# INTERNATIONAL SEARCH REPORT

Application No  
PCT/GB2004/000850

<b>A. CLASSIFICATION OF SUBJECT MATTER</b> IPC 7 B05C17/005 B65D77/18 B65D83/00		
According to International Patent Classification (IPC) or to both national classification and IPC		
<b>B. FIELDS SEARCHED</b> Minimum documentation searched (classification system followed by classification symbols) IPC 7 B05C B65D		
Documentation searched other than minimum documentation to the extent that such documents are included in the fields searched		
Electronic data base consulted during the international search (name of data base and, where practical, search terms used) EPO-Internal		
<b>C. DOCUMENTS CONSIDERED TO BE RELEVANT</b>		
Category °	Citation of document, with indication, where appropriate, of the relevant passages	Relevant to claim No.
X A  X A  X	DE 296 06 463 U (THERA GES FUER PATENTE) 7 August 1997 (1997-08-07) the whole document ----- US 6 048 201 A (ZWINGENBERGER ARTHUR) 11 April 2000 (2000-04-11) column 5, line 30 - column 6, line 9 column 7, line 45 - line 52; figures 4,5,7 ----- US 5 304 396 A (LUND WILLIAM J) 19 April 1994 (1994-04-19) column 4, line 18 - line 29; figures 2,3 ----- -/--	1-13, 15-25 14  1-5,7-25  6  1-5, 7-13, 16-25
<input checked="" type="checkbox"/> Further documents are listed in the continuation of box C. <span style="margin-left: 200px;"><input checked="" type="checkbox"/> Patent family members are listed in annex.</span>		
° Special categories of cited documents :		
*A* document defining the general state of the art which is not considered to be of particular relevance *E* earlier document but published on or after the international filing date *L* document which may throw doubts on priority claim(s) or which is cited to establish the publication date of another citation or other special reason (as specified) *O* document referring to an oral disclosure, use, exhibition or other means *P* document published prior to the international filing date but later than the priority date claimed	*T* later document published after the international filing date or priority date and not in conflict with the application but cited to understand the principle or theory underlying the invention *X* document of particular relevance; the claimed invention cannot be considered novel or cannot be considered to involve an inventive step when the document is taken alone *Y* document of particular relevance; the claimed invention cannot be considered to involve an inventive step when the document is combined with one or more other such documents, such combination being obvious to a person skilled in the art. *&* document member of the same patent family	
Date of the actual completion of the international search  <p style="text-align: center;">1 June 2004</p>	Date of mailing of the international search report  <p style="text-align: center;">14/06/2004</p>	
Name and mailing address of the ISA European Patent Office, P.B. 5818 Patentlaan 2 NL - 2280 HV Rijswijk Tel. (+31-70) 340-2040, Tx. 31 651 epo nl, Fax: (+31-70) 340-3016	Authorized officer  <p style="text-align: center;">Jelercic, D</p>	

## INTERNATIONAL SEARCH REPORT

Application No  
PCT/GB2004/000850

C.(Continuation) DOCUMENTS CONSIDERED TO BE RELEVANT		
Category °	Citation of document, with indication, where appropriate, of the relevant passages	Relevant to claim No.
X	<p>GB 2 019 952 A (ANDERSON S R) 7 November 1979 (1979-11-07) page 4, line 127 - page 5, line 26; figure 6</p> <p>-----</p>	1,4,12, 16,18,20
A	<p>EP 0 747 114 A (CHAN KWAN HO) 11 December 1996 (1996-12-11)</p> <p>column 5, line 58 - column 6, line 15 column 7, line 58 - column 8, line 18 column 9, line 42 - column 10, line 7; figures 1,4</p> <p>-----</p>	1,4,5,7, 9,12,13, 16-20
A	<p>US 4 981 241 A (KELLER WILHELM A) 1 January 1991 (1991-01-01)</p> <p>column 3, line 64 - column 4, line 12; figures 1,3,5</p> <p>-----</p>	1,4,5,7, 9,12,13, 16-20
A	<p>US 5 033 650 A (HARKINS BERNARD F ET AL) 23 July 1991 (1991-07-23)</p> <p>column 3, line 21 - line 41 column 4, line 55 - line 65; figures 3,6</p> <p>-----</p>	1,4,5,7, 9,12,13, 16-20

## INTERNATIONAL SEARCH REPORT

 Application No  
 PCT/GB2004/000850

Patent document cited in search report		Publication date	Patent family member(s)	Publication date
DE 29606463	U	07-08-1997	DE 29606463 U1	07-08-1997
US 6048201	A	11-04-2000	CA 2247801 A1	15-04-1999
			EP 0910995 A2	28-04-1999
			JP 11216398 A	10-08-1999
US 5304396	A	19-04-1994	NONE	
GB 2019952	A	07-11-1979	CA 1122927 A1	04-05-1982
			DE 2918121 A1	15-11-1979
			FR 2424856 A1	30-11-1979
			JP 1481383 C	10-02-1989
			JP 54152596 A	30-11-1979
			JP 63030229 B	16-06-1988
			US 4366919 A	04-01-1983
EP 0747114	A	11-12-1996	US 6409972 B1	25-06-2002
			CA 2168274 A1	07-12-1996
			CN 1138001 A	18-12-1996
			DE 69623181 D1	02-10-2002
			EP 0747114 A1	11-12-1996
			US 6302574 B1	16-10-2001
US 4981241	A	01-01-1991	DE 3873628 D1	17-09-1992
			EP 0294672 A1	14-12-1988
			JP 1037377 A	08-02-1989
			JP 1885749 C	22-11-1994
			JP 6010019 B	09-02-1994
US 5033650	A	23-07-1991	US 4753536 A	28-06-1988
			US 4995540 A	26-02-1991