

W. HOEY.  
HOISTING MECHANISM.

No. 526,488.

Patented Sept. 25, 1894.

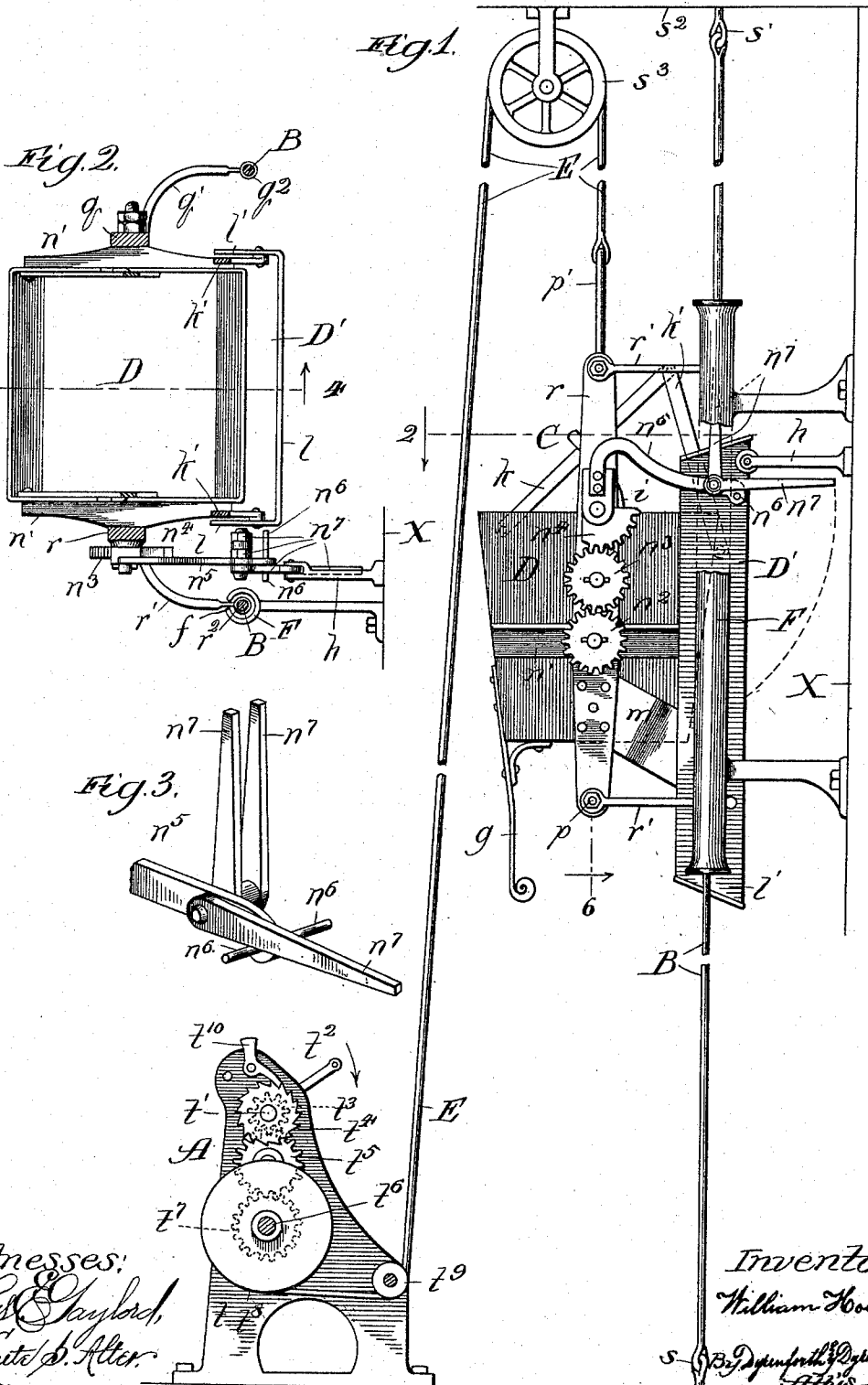

Witnesses:  
*Ed. S. Clark,*  
*Lute S. Allen.*

Inventor:  
*William Hoey,*

*S. B. Dyer, Atty.*

W. HOEY.  
HOISTING MECHANISM.

No. 526,488.

Patented Sept. 25, 1894.

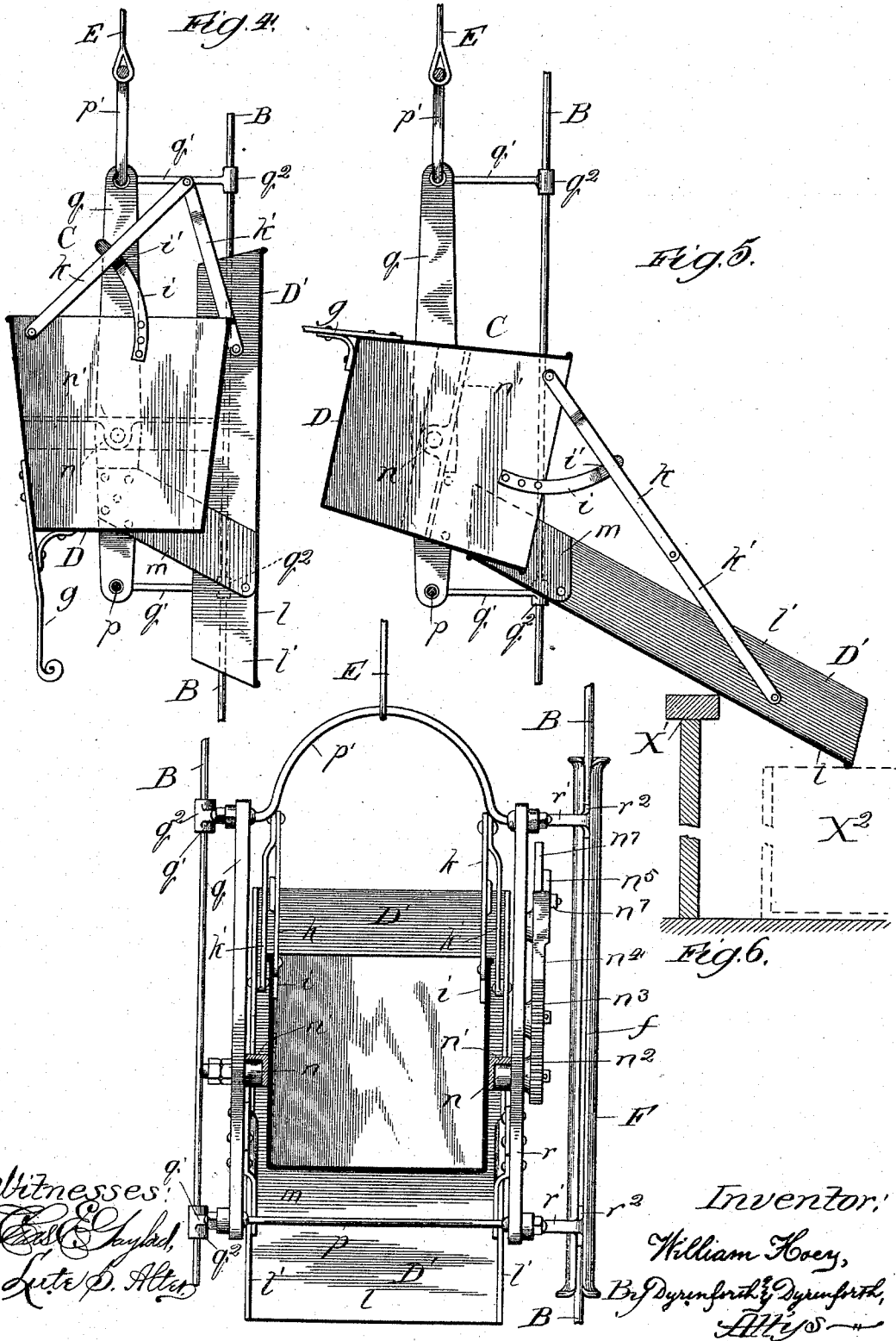

# UNITED STATES PATENT OFFICE.

WILLIAM HOEY, OF GRAND RAPIDS, MICHIGAN.

## HOISTING MECHANISM.

SPECIFICATION forming part of Letters Patent No. 526,488, dated September 25, 1894.

Application filed January 6, 1894. Serial No. 495,887. (No model.)

*To all whom it may concern:*

Be it known that I, WILLIAM HOEY, a citizen of the United States, residing at Grand Rapids, in the county of Kent and State of Michigan, have invented a new and useful Improvement in Hoisting Mechanism, of which the following is a specification.

My invention relates to improved hoisting mechanism for use, more especially, at apartment houses to elevate and deliver coal or other articles to the upper stories; and my object is to provide simple and durable improved hoisting mechanism for the purpose, which may be operated from the ground, or filling position, to carry up the articles and discharge them at the desired story.

In the drawings—Figure 1 is a broken diagrammatic view of my improvements in operation; Fig. 2, a section taken on line 2 of Fig. 1, and viewed in the direction of the arrows; Fig. 3, an enlarged broken perspective view of a detail of bucket upsetting mechanism; Fig. 4, a section taken on line 4 of Fig. 2, showing a bucket and chute thereon in upright and folded position; Fig. 5, a view the same as Fig. 4, showing the bucket and chute in upset and unfolded position; and Fig. 6, a section taken on line 6 of Fig. 1, and viewed in the direction of the arrow.

Anchored to the ground is a windlass A, which may be constructed with side frames *l*, in which are journaled an operating shaft *t'* having a crank *t''*, and carrying a pinion *t'''* and ratchet wheel *t''''*; an idle pinion *t''''''* engaging the pinion *t'''*; a shaft *t''''''* carrying a pinion *t''''''''*, engaging the idle pinion *t''''''*, and a cable winding drum *t''''''''''*; a shaft carrying a cable-guide sheave *t''''''''''''*; and a pivoted pawl *t''''''''''''''* to engage the ratchet-wheel *t''''''*; all the parts being disposed with relation to each other as shown in Fig. 1.

B B are vertically disposed and parallel rods or cables, affording a guide, which extends close to the side of the house, the rods or cables being secured at their lower ends to suitable stationary fasteners *s*, and secured at their upper ends to suitable fasteners *s'* on an overhead support *s''*, and drawn tightly between the fastenings, to extend taut.

It is a common practice in building apartment houses to provide a veranda at each story, on the rear side of the house, the ve-

randas being supported at their outer corners by uprights or pillars, between which extend guard-railings. The verandas thus constructed are often provided with boxes or bins for containing coal, kindling and the like.

My improved hoisting mechanism, constructed as shown and hereinafter described, is particularly adapted for use in connection with apartment houses of the class mentioned, the windlass being anchored at any suitable place in the yard, and the guide-cables B, caused to extend beyond and close to the outer side of the verandas.

C is a carrier-frame comprising side-bars *r* *q*, tied together and held in rigid relation at their lower ends by means of a cross-rod *p* and at their upper ends by means of a bail *p'*. At the upper and lower ends of the side-bars *r* and *q* are arms *r'* *q'*, respectively, provided at their free ends with hollow tubular heads *r''* *q''*, which fit loosely around and slide upon the cables B.

Mounted upon trunnions *n* journaled in the side-bars, is an upsetting-bucket D. The trunnions *n* are secured to angle-iron braces *n'* on the sides of the bucket, and one of the trunnions extends beyond the side-bar *r* and carries a pinion *n''*. Journaled upon the side-bar *r*, is an idle-pinion *n'''*, above and engaging the pinion *n''*, and a segmental gear *n''''*, above and engaging the pinion *n''*. Secured upon the segment *n''''* is an arm *n''''''*, provided at its free end with a stop or pin *n''''''''*. Pivoted upon the arm *n''''''*, near its free end, are parallel fingers *n''''''''* separated from each other to extend some distance apart. The fingers may be swung from an upright or retracted position, to the position of bearing against the stop *n''''''''*, and are held with sufficient friction at their pivots to remain in either adjusted position, shown in Fig. 3.

On each side-bar is an inclined strip or support *m*, and pivoted at opposite sides to the said strips is an extensible and retractible chute D', formed with a base-plate *l* and side plates *l'*. At its lower end the chute extends below the bucket D, and at its upper end-portion it is connected to the bucket by means of levers, each consisting of two pivotally connected links *k* *k'*. Each link *k* is pivoted at its end to the side of the bucket, near the top of the latter, and each link *k'* is

pivoted to one of the sides  $l'$  of the chute. On each side of the bucket is an arm  $i$ , bent to afford a stop  $i'$  to engage the respectively adjacent link  $k$ , as hereinafter described.

5 E is a cable, or other flexible medium, secured at one end to the drum  $t^8$ , extending thence under the sheave  $t^9$ , and over a pulley  $s^3$ , suspended from the overhead support  $s^2$ , to the bail  $p'$  on the bucket, to which it is secured at its opposite end.

10 The frame C with the bucket and chute, carried thereby, may be raised and lowered upon the guides B, by turning the crank  $t^2$  to wind up or pay out the cable E, and may be held at any elevation on the guides by causing the pawl  $t^{10}$  to engage the ratchet-wheel  $t^4$ .

20 Supported at each story of the house, is a stop-projection  $h$  extending into the path of one of the fingers  $n^7$ , the stop-projections at the different stories being respectively in the paths of different fingers, and out of the path of the other fingers.

25 In the case of an apartment building constructed with verandas, as described, the stop-projections  $h$  may be secured to the pillar or upright X, at one side.

30 The bucket D is weighted at its base to extend normally upright, with the chute folded, as shown for example in Fig. 1, and, if desired, weighted legs  $g$  may be provided on the bucket to extend down to the plane of the lower end of the chute, when folded, whereby when the bucket is lowered to the ground it may stand upon the chute and legs.

35 In operation, to deliver coal, for example, to a certain story of a house, the finger  $n^7$  which registers with the stop at that story is swung down to the stop  $n^6$ , the other fingers being raised. The frame C is lowered to the filling position, and after the bucket has been filled, it is raised by means of the windlass. In passing the stop projection  $h$  at the proper story, the extended finger  $n^7$  will be engaged by the stop-projection and swung with the arm  $n^5$  downward, to rotate the segment  $n^4$ , idle-pinion  $n^3$ , and pinion  $n^2$  and cause the bucket to upset. While the bucket turns on its bearings to upset, the stops  $i'$  will tend to recede from the links  $k$  and permit the chute to swing on its pivot until the bucket and chute extend as shown in Fig. 5. When the bucket is upset all its contents will run out upon the chute, and the latter may thus be caused to direct the coal, or other articles over a veranda railing  $X'$  to a bin  $X^2$ . As the frame C is lowered the bucket will assume an upright position, and in doing so the stops  $i'$  will engage the links  $k$  and fold the chute.

55 Supported adjacent to the stops  $h$  are stationary hollow guide-tubes F, through which the cable B on that side extends. The tubes are large enough to permit the heads  $r^2$  on the arms  $r'$  to pass through, and they are made flaring at their upper and lower ends

so that the heads may readily enter them. The tubes are provided with longitudinal slots, slightly narrower than the diameter of the cable, in order that the latter may not become displaced, but wide enough to permit the arms  $r'$ , adjacent to the heads  $r^2$ , to slide through without obstruction. The tubes F guide the carrier-frame, to insure engagement of the respective fingers  $n^7$  with the adjacent stop  $h$ ; and while the bucket and chute are being upset and righted again, they operate to steady the frame.

80 Constructed as described, my improved hoist affords a particularly desirable and comparatively inexpensive labor-saving mechanism, and while I prefer to construct it throughout as shown and described, it may be modified in the matter of details of construction without departing from the spirit of my invention as defined by the claims.

85 What I claim as new, and desire to secure by Letters Patent, is—

1. In a hoisting apparatus, the combination of a carrier frame, an upsetting bucket pivotally mounted on the said frame, a guide for the frame, bucket upsetting gear and an operating lever therefor on the frame, driving mechanism for moving the frame on its guide between the bucket filling and dumping positions, and a stop projection supported at the said dumping position in the path of the said operating lever, whereby in the movement of the frame to the dumping position, the stop projection engages the said operating lever and moves the said gear to upset the bucket, substantially as and for the purpose set forth.

2. In a hoisting apparatus, the combination of a carrier-frame, a guide for the frame, bucket upsetting gear and an operating lever therefor on the frame, a pivotally mounted extensible and retractible chute on the frame connected with the bucket, driving mechanism for moving the frame on its guide between the bucket filling and dumping positions, and a stop-projection supported at the said dumping position in the path of the said operating lever, whereby in the movement of the frame to the dumping position the stop-projection engages and turns the operating lever to move the gear, to upset the bucket and extend the chute, substantially as and for the purpose set forth.

3. In a hoisting apparatus, the combination of a carrier-frame, a bucket mounted upon trunnions in said frame, a bucket upsetting lever on the frame geared to a bucket-trunnion, extensible and retractible fingers on the said lever, a guide for the frame, driving-mechanism for moving the frame on the said guide, and stop-projections  $h$  supported at different points along the guide to project into the paths of the said fingers, substantially as and for the purpose set forth.

4. In a hoisting apparatus, the combination of a carrier-frame, an upsetting bucket mounted on trunnions in said frame, a bucket

upsetting lever on the frame geared to a bucket trunnion, guides B B, arms on the frame engaging and moving on the said guides, driving mechanism for moving the frame on the guides between the bucket filling and dumping positions, a frame steadying guide F at the dumping position and a stop-projection at the said dumping position in the path of said operating lever, substantially as and for the purpose set forth.

5. In a hoisting apparatus, the combination of a carrier-frame C, a normally upright upsetting bucket D mounted on trunnions in the frame, a chute D' pivotally mounted on the frame below the bucket trunnions, a lever connection between the bucket and chute comprising pivotally connected links  $k$   $k'$ , a stop-projection  $i$  on the bucket operating to engage the links  $k$  and fold the chute as the bucket is righted and recede from the link as the bucket is upset to permit the chute to extend, a guide for the frame, driving-mechanism for moving the frame on its guide between the bucket-filling and a bucket-dumping position, and means for upsetting the bucket

at the said dumping position, substantially as and for the purpose set forth.

6. In a hoisting apparatus, the combination of a carrier-frame C, guides B, driving-mechanism for moving the frame on the said guides between the bucket-filling and dumping positions, a frame steadying guide F at the said dumping position, a normally upright upsetting bucket D mounted upon trunnions in the said frame, a bucket upsetting lever on the frame geared to a bucket trunnion, a stop-projection  $h$  in the path of the said lever at the dumping position, an extensible and retractible chute D' pivoted at its lower end-portion to the frame below the bucket trunnions, and a folding lever between the chute and bucket operating to extend the chute as the bucket is upset, and retract the chute as the bucket is righted, substantially as and for the purpose set forth.

WILLIAM HOEY.

In presence of—

M. J. FROST,

W. N. WILLIAMS.