



- (51) International Patent Classification:
A61B 17/12 (2006.01)
- (21) International Application Number:
PCT/US2012/041285
- (22) International Filing Date:
7 June 2012 (07.06.2012)
- (25) Filing Language: English
- (26) Publication Language: English
- (30) Priority Data:
61/494,845 8 June 2011 (08.06.2011) US
- (71) Applicant (for all designated States except US): **SEN-TREHEART, INC.** [US/US]; 300 Saginaw Drive, Redwood City, CA 94063 (US).
- (72) Inventors; and
- (75) Inventors/Applicants (for US only): **FUNG, Gregory, W.** [US/US]; 301 San Miguel Avenue, San Mateo, CA 94403 (US). **HELMUTH, Ryan, Douglas** [US/US]; 19831 Robin Way, Saratoga, CA 95070 (US). **ESCANO, Arnold, M.** [US/US]; 2095 Denise Drive, Santa Clara, CA 95050 (US). **SEIBER, Russell, A.** [US/US]; 108 Monaco Drive, Redwood City, CA 94065 (US). **CLARK, Robert, L.** [US/US]; 3505 Hackamore Drive, Hayward, CA 94541 (US).

(74) Agents: **BELUSKO, Vincent, J.** et al.; Morrison & Foerster LLP, 755 Page Mill Road, Palo Alto, CA 94304-1018 (US).

(81) Designated States (unless otherwise indicated, for every kind of national protection available): AE, AG, AL, AM, AO, AT, AU, AZ, BA, BB, BG, BH, BR, BW, BY, BZ, CA, CH, CL, CN, CO, CR, CU, CZ, DE, DK, DM, DO, DZ, EC, EE, EG, ES, FI, GB, GD, GE, GH, GM, GT, HN, HR, HU, ID, IL, IN, IS, JP, KE, KG, KM, KN, KP, KR, KZ, LA, LC, LK, LR, LS, LT, LU, LY, MA, MD, ME, MG, MK, MN, MW, MX, MY, MZ, NA, NG, NI, NO, NZ, OM, PE, PG, PH, PL, PT, QA, RO, RS, RU, RW, SC, SD, SE, SG, SK, SL, SM, ST, SV, SY, TH, TJ, TM, TN, TR, TT, TZ, UA, UG, US, UZ, VC, VN, ZA, ZM, ZW.

(84) Designated States (unless otherwise indicated, for every kind of regional protection available): ARIPO (BW, GH, GM, KE, LR, LS, MW, MZ, NA, RW, SD, SL, SZ, TZ, UG, ZM, ZW), Eurasian (AM, AZ, BY, KG, KZ, RU, TJ, TM), European (AL, AT, BE, BG, CH, CY, CZ, DE, DK, EE, ES, FI, FR, GB, GR, HR, HU, IE, IS, IT, LT, LU, LV, MC, MK, MT, NL, NO, PL, PT, RO, RS, SE, SI, SK, SM, TR), OAPI (BF, BJ, CF, CG, CI, CM, GA, GN, GQ, GW, ML, MR, NE, SN, TD, TG).

Published:

— with international search report (Art. 21(3))

(54) Title: TISSUE LIGATION DEVICES AND TENSIONING DEVICES THEREFOR

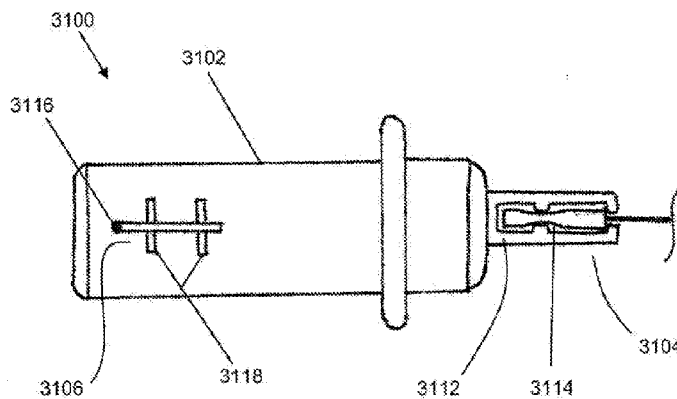

FIG. 31A

(57) Abstract: Described here are closure devices and methods for ligating tissue, such as the left atrial appendage, and tensioning devices and mechanism for actuating these devices. The tensioning mechanisms and devices may allow a user to apply one or more predetermined forces to a suture or other portion of the closure devices. The closure devices may comprise a suture loop releasably attached to a snare loop assembly, and a tensioning mechanism or device may be configured to tighten the suture loop and/or release the suture loop from the snare loop assembly

WO 2012/170652 A1

TISSUE LIGATION DEVICES AND TENSIONING DEVICES THEREFOR**CROSS-REFERENCE TO RELATED APPLICATIONS**

[0001] This application claims priority to U.S. Provisional Application Serial No. 61/494,845, filed on June 8, 2011, which is hereby incorporated by reference in its entirety.

FIELD

[0002] This invention relates generally to devices and methods for ligating tissue, such as the left atrial appendage, using surgically, minimally invasive or intravascular approaches, and to tensioning devices for actuating these devices.

BACKGROUND

[0003] Atrial fibrillation is a common problem that afflicts millions of patients. Atrial fibrillation often results in the formation of a thrombus, or clot, in the appendage of the left atrium. This presents a problem, inasmuch as the thrombus can dislodge and embolize to distant organs, which may result in adverse events such as a stroke. For this reason, most patients with atrial fibrillation are treated with one or more blood thinners to help prevent the formation of a thrombus. Blood thinners, however, can present health risks of their own, especially in the elderly. These risks, such as bleeding, often require a user to make significant lifestyle changes.

[0004] Several methods have been developed to address the potential problem of thrombus formation in the left atrial appendage. One such method includes suturing the left atrial appendage along the base or ostial neck where it joins the atrial chamber. In this way, blood flow into the atrial appendage is cut off, eliminating the risk of thrombus formation therein. This is typically done through open-heart surgery, which limits the availability of the procedure to those who are at a particularly high risk, or who are otherwise undergoing an open-heart procedure. In addition, open-heart surgery requires general anesthesia and has a number of well-known risks, making it less desirable.

[0005] Other methods have also been investigated. These methods include methods of stapling the base of the appendage and methods of filling the appendage with a space occupying or occluding member. Stapling is not preferred given the fragility of the appendage and its tendency to rupture, while occlusion devices may not effectively prevent all blood flow into the appendage.

[0006] Additional devices and methods for closing the left atrial appendage or other suitable tissues would therefore be desirable. In particular, devices and methods for closing the left atrial appendage using minimally invasive, intravascular, or a combination of these techniques, would be desirable in order to avoid the need for opening the chest. Of course, additional devices for use in open surgical procedures are desirable as well, especially when those devices offer additional advantages over standard devices.

BRIEF SUMMARY

[0007] Described here are closure devices for closing one or more tissues, and mechanisms for controlling these devices. Generally, the closure devices described here comprise a snare loop assembly, wherein the snare loop assembly comprises a snare and a suture loop, an elongate body, and a mechanism for controlling the snare loop assembly which may be mounted on a handle. In some variations the snare loop assembly may comprise a retention member that may releasably couple the suture loop and the snare. In other variations the devices comprise one or more force-reducing suture locks to help prevent the suture loop from inadvertently disengaging from the snare loop assembly. Additionally, the closure devices may comprise one or more tensioning devices for tensioning or otherwise tightening the suture loop.

[0008] In some variations, the tensioning device may comprise a force gauge. In some variations, the tensioning device may further comprise a handle portion, a suture attachment mechanism, and a force indicator. Suture attachment mechanism may be one or more structures capable of coupling, permanently or reversibly, to a portion of a suture loop (e.g., a tail of the suture). In some variations, the suture attachment mechanism may be configured to attach to a suture fob that is in engagement with a portion of the suture loop. In some variations, the suture attachment mechanism may be attached to the force gauge, such that tension applied to the suture by the tensioning device may be measured by the force gauge. In variations that include a force indicator, the force indicator may give an indication of the tension measured by the force gauge. In some variations, the force indicator may comprise a digital display, which may display the force measured by the force gauge. In other variations, the force indicator may comprise one or more lights, which may turn on (or off) when the tension measured by the force gauge reaches one or more predetermined tension levels. In other variations, the force indicator may comprise a moveable marker which may move along a scale as a function of the tension measured by the force gauge. In some variations, the scale may comprise one or more marks which may represent one or more predetermined tension values.

[0009] In other variations, the tensioning device may comprise one or more clutches. In some variations, the tensioning device may comprise a base, a rotation knob, a spooling member, a first clutch, and a second clutch. In some variations, the base of the tensioning member may be attached to a handle of a closure member. In some variations, the first and second clutch may frictionally engage the spooling member. In some variations, rotation of the rotation knob may rotate the first clutch, and the frictional engagement between the first clutch and the spooling member may cause the spooling member to rotate relative to the base. In some of these variations, the suture may be attached to the spooling member, such that rotation of the spooling member causes the suture to wrap around the spooling member. In some variations, the rotation knob comprises a switch and an engagement rod, and wherein the switch is moveable between a first position in which the engagement rod may rotate relative to the second clutch, and a second position in which the engagement rod engages a second clutch and is rotatably connected to the second clutch. In some of these variations, when the switch is in the first position, rotation of rotation knob may cause spooling member to rotate around the base until the tension in the suture reaches a first predetermined force. Once the tension reaches the first predetermined force, the first clutch may begin to slip relative to the spooling member such that the spooling member is no longer rotated. In some variations, the switch may be placed in the second position to engage the second clutch, and rotation of rotation knob may cause spooling member to rotate around the base until the tension in the suture reaches a second predetermined force. Once the tension reaches the second predetermined force, the first and second clutches may begin to slip relative to the spooling member such that the spooling member is no longer rotated.

[0010] In other variations the tensioning device may comprise one or more constant force springs. In some of these variations, the tensioning device may comprise a housing; a first extension member slidable relative to housing; a first constant force spring attached to the housing and the first extension member and a suture attachment mechanism for coupling the tensioning device to a portion of a suture loop. In some of these variations, the tensioning device may comprise a second extension member and a second constant force spring, wherein the second constant force spring may be attached to the housing and the second extension member. In some of these variations, the first extension member may be releasably couplable to the second extension member.

[0011] In other variations, a closure device may comprise a tensioning mechanism comprising a rotation knob, an indicator body, and a spring member rotatably connecting the rotation knob and the indicator body. In some of these variations, rotation of the rotation knob may tighten a

suture loop, the relative rotational positioning between the rotation knob and the indicator body may indicate an amount of force applied to a portion of the suture loop (e.g., a tail of the loop). In some variations, the tensioning mechanism may further comprise an axle, wherein the indicator body and axle are fixedly connected and wherein the indicator body and axle are rotatably coupled to a handle of the closure device. In some of these variations, the tensioning mechanism may further comprise a spool, wherein rotation of the axle rotates the spool. In these variations, rotation of the spool may tighten the suture loop. In some variations, the indicator body may comprise at least one marking, the rotation knob may comprise at least one marking, and the relative positioning between the at least one marking of the indicator body and the at least one marking of the rotation knob may indicate an amount of force applied to the suture loop.

[0012] Also described here are methods for closing one or more tissues. For example, in some variations, a method may comprise introducing a closure device into a body, wherein the closure device comprises a snare loop assembly having an opened configuration and a closed configuration and comprising a suture loop releasably coupled to the snare loop assembly, advancing the snare loop assembly to ensnare the target tissue, closing the snare loop assembly around the target tissue; applying a first predetermined tension to the suture loop to release the suture loop from the snare loop assembly, and applying a second predetermined tension to the suture loop to tighten the suture loop around the target tissue. In some variations, the target tissue may comprise the left atrial appendage. In some variations, the methods may comprise opening the snare loop assembly to the open configuration after releasing the suture loop from the snare loop assembly. Additionally or alternatively, the method may further comprise re-tightening the suture loop after a first time period following applying the second predetermined tension to the suture loop. In some of these variations, the first time period may be at least thirty seconds. In other variations, the first time period may be at least two minutes. Additionally or alternatively, in some variations re-tightening the suture loop may comprise applying a third predetermined tension to the suture loop. The third predetermined tension may be greater than or less than the second predetermined tension. In other methods, re-tightening the suture loop may comprise applying the second predetermined tension to the suture loop. In some variations, applying the first predetermined tension to the suture loop may comprise applying the first predetermined tension to the suture loop using a first tensioning device. In some of these variations, applying the second predetermined tension to the suture loop may comprise applying the second predetermined tension to the suture loop using the first tensioning device. In others

of these variations, applying the second predetermined tension to the suture loop may comprise applying the second predetermined tension to the suture loop using a second tensioning device. Any suitable tensioning device (or combination of tensioning device), such as those described hereinthroughout, may be used with the methods described here.

BRIEF DESCRIPTION OF THE DRAWINGS

[0013] FIG. 1 is a view of a distal end of an illustrative device having a snare loop assembly.

[0014] FIG. 2 is a view of a distal end of a snare loop assembly, including a suture hook.

[0015] FIG. 3A is a perspective view of one variation of a handle suitable for use with the devices described here. FIG. 3B is a cross-sectional bottom view of the handle shown in FIG. 3A.

[0016] FIGS. 4-9 are perspective views of variations of handles suitable for use with the devices described here.

[0017] FIGS. 10 and 11 are cross-sectional side views of portions of two variations of the closure devices described here.

[0018] FIGS. 12 and 13A-13C illustrate two variations of snare loop assemblies suitable for use with the closure devices described here.

[0019] FIG. 14 shows a perspective view of an illustrative variation of the closure devices described here.

[0020] FIG. 15 shows a cross-sectional side view of a portion of one variation of the closure devices described here comprising a pulley suture.

[0021] FIGS. 16A-16B illustrate a variation of the closure devices described here in which a snare is releasably connected to an elongate body.

[0022] FIGS. 17A-17D illustrate different illustrative variations of snare configurations.

[0023] FIGS. 18A and 18B depict a perspective view and a side view, respectively, of a variation of a snare. FIGS. 18C and 18D depict a method by which the snare of FIGS. 18A and 18B may be used to ensnare tissue.

[0024] FIGS. 19A-19G illustrate several variations of knot shielding mechanisms suitable for use with the closure devices described here.

[0025] FIGS. 20A-20C depict illustrative retention members that may be used with the devices described here.

[0026] FIG. 21 depicts an illustrative variation of an elongate body suitable for use with the devices described here.

[0027] FIGS. 22A and 22B depict a perspective view and a top view, respectively, of one variation of separation tubing suitable for use with the devices described here. FIGS. 22C and 22D depict a perspective view and a top view, respectively, of another variation of separation tubing suitable for use with the devices described here.

[0028] FIG. 23A depicts a front view of one illustrative variation of a tip portion suitable for use with the devices described here. FIGS. 23B and 23C depict cross-sectional side views of the tip portion of FIG. 23A.

[0029] FIGS. 24A and 24B depict portions of two variations of tip portions suitable for use with the devices described here.

[0030] FIGS. 25A-25C depicts a perspective view, a front view, and a cross-sectional side view, respectively of an illustrative variation of a tip portion suitable for use with the devices described here. FIG. 25D illustrates a cross-sectional side view of one variation of a closure device incorporating the tip portion illustrated in FIGS. 25A-25C.

[0031] FIGS. 26A and 26B show an illustrative variation of a closure device comprising separation tubing.

[0032] FIG. 27 depicts an illustrative variation of a closure device comprising separation tubing and a suture tube.

[0033] FIGS. 28A and 28B depict a variation of a suture tube suitable for use with the devices described here.

[0034] FIG. 29 depicts a cross-sectional side view of a suture tube suitable for use with the devices described here.

[0035] FIGS. 30A-30D depict a variation of the closure devices described here comprising a pulley suture.

[0036] FIGS. 31A and 31B depict two variations of tensioning devices suitable for use with the closure devices described here.

[0037] FIGS. 32A depicts a perspective view of a variation of a tensioning device suitable for use with the closure devices described here. FIGS. 32B and 32C depict partial cross-sectional views of the tensioning device shown in FIG. 32A.

[0038] FIGS. 33A-33G depict a variation of a tensioning device suitable for use with the closure devices described here.

[0039] FIG. 34 depicts a method of using a closure device having a suture loop to close a tissue.

[0040] FIGS. 35A-35D depict a variation of a closure device comprising a tensioning mechanism.

DETAILED DESCRIPTION

[0041] Described here are closure devices, handles and tensioning devices for actuating closure devices, and methods for closing tissues using one or more closure devices. Generally, the closure devices comprise a snare loop assembly comprising a snare and a suture loop, such as those described in U.S. Patent Application No. 12/055,213, entitled "Devices, Systems, and Methods for Closing the Left Atrial Appendage" and filed on March 5, 2008, and U.S. Patent Application No. 12/752,873, entitled "Tissue Ligation Devices and Controls Therefor" and filed on April 1, 2010, each of which is incorporated by reference herein in their entirety. The devices described here may be suitable for use with minimally invasive access to the left atrial appendage (e.g., through a small incision above, beneath or through the rib cage, through an incision in the costal cartilage or the xiphoid, through a port, through the vasculature, etc.).

[0042] Generally, the closure devices described here comprise an elongate body, and a snare loop assembly. In some variations the closure devices may further comprise a handle and/or a tensioning device. A handle or other control mechanism (e.g., a surgical master-slave robotic system) may be used to control and actuate the snare loop assembly through the elongate body, as will be explained in more detail below. The snare loop assembly, in turn, may be used to

temporarily or permanently close, tighten, ligate or other restrict tissue. To achieve this, the snare loop assembly may be changed between a delivery, or “closed,” configuration and a deployed, or “open,” configuration, and vice versa, as will be described in more detail below. Placing the snare loop assembly in a closed configuration may allow for low-profile advancement of the snare loop assembly to a target location, or may allow the snare loop assembly to close around a target tissue. Conversely, placing a snare loop assembly in an open configuration may allow the snare loop assembly to be placed around one or more target tissues, or may allow the snare loop assembly to release one or more target tissues previously closed by the snare loop assembly.

[0043] In use, a distal end of an elongate body may be advanced into the body toward a target tissue (e.g., the left atrial appendage). This advancement may be done in a minimally invasive manner. During advancement, the snare loop assembly may be in a closed configuration to help prevent the snare loop assembly from snagging or catching on tissue or other obstructions. Once the distal end of the elongate body has reached a location at or near the target tissue, the snare loop assembly may be opened to a deployed configuration. The snare loop assembly may then be advanced, moved, or otherwise manipulated to encircle at least a portion of the target tissue. The snare loop assembly may then be closed around the encircled tissue to close, ligate, or otherwise restrict the target tissue. The snare loop assembly may be re-opened, repositioned, and re-closed as necessary. In some instances, a suture loop (not shown) or other restricting device may be tightened and released from the closure device to maintain the target tissue in a closed fashion. To remove the closure device from the body, the snare loop assembly may again be opened to release the target tissue (it should be appreciated that the suture loop or other closure device may remain in place) such that the snare loop assembly and elongate body may be withdrawn. Once the target tissue is released, the snare loop assembly may be closed to facilitate low-profile withdrawal. In variations where the closure device comprises a tensioning device or mechanism, the tensioning device or mechanism may be used to release the suture loop from the snare loop assembly and/or tighten the suture loop, as will be described in more detail below.

[0044] The closure devices may contain one or more additional features, as will be described in more detail below. In some variations, the snare loop assembly comprises one or more force-reducing suture locks. These elements, as will be described in more detail below, may act to releasably or permanently connect various components of the snare loop assembly while reducing forces that are transmitted to one or more portions of the snare loop assembly. In other

variations, the closure device may comprise one or more features that helps maintain at least a portion of the suture loop inside of the elongate body when the device is in an opened and/or closed configuration. In some of these variations, the closure device may comprise a suture hook that engages a portion of the snare loop assembly. In other variations, the elongate body may comprise one or more pieces of separation tubing. This separation tubing may further comprise a suture tube attached thereto for releasably holding at least a portion of the suture loop. In still other variations, the elongate body may comprise a pulley suture that engages one or more portions of the snare loop assembly. Each of these features will be described in more detail below, and it should be appreciated that the closure devices described here may comprise any combination of these features.

[0045] FIG. 14 depicts one illustrative variation of closure device (1400). Shown there is snare loop assembly (1402), elongate body (1404), and handle (1406). As noted above, handle (1406) may be used to control and actuate the snare loop assembly (1402) through the elongate body (1404) in order to move snare loop assembly (1402) between a closed configuration (as shown in FIG. 14) and a deployed configuration (not shown), and vice versa.

SNARE LOOP ASSEMBLY

[0046] As mentioned above, the snare loop assemblies of the closure devices described here may be used to temporarily close or restrict one or more target tissues. Generally the snare loop assembly comprises a snare, a suture loop, and a retention member at least temporarily connecting the snare and the suture loop. The snare loop assembly may also comprise one or more force-reducing suture locks, as will be described in more detail below. FIG. 1 shows an illustrative variation of snare loop assembly (100) comprising snare (102), suture loop (104), and retention member (106). Snare loop assembly (100) may be at least partially disposed in elongate body (108) having tip (110). Snare loop assembly (100) is shown in FIG. 1 in an open configuration, and the portion of snare loop assembly (100) extending out of elongate body (108) may define a continuous aperture therethrough. This aperture may be defined by one or more components of the snare loop assembly (100) (e.g., the snare), and may be suitable for encircling tissue such as the left atrial appendage. Generally, the snare (102) may be used to open and close the snare loop assembly (100), as will be described in more detail below. In some instances, retention member (106) may be configured to releasably couple suture loop (104) and snare (102), and may be configured to release suture loop (104) from snare loop assembly (100) upon application of sufficient force to suture loop (104).

Snare

[0047] In variations of snare loop assemblies comprising a snare, the snare may be at least partially moveable to change a snare loop assembly between open and closed configurations. Generally, a portion of the snare may be housed in the elongate body, and another portion of the snare may extend outside of the distal end of the elongate body to at least partially define the aperture of the snare loop assembly. In some variations, one end of the snare is fixed relative to one or more portions of the closure device, while the other end may be advanced or retracted through the elongate body. Movement of the free end of snare may change the amount of the snare loop assembly that is disposed outside of elongate body, and thus change the size of the aperture defined thereby. Specifically, advancement of the snare through the elongate body may increase the size of the snare loop assembly aperture, while retraction of the snare may decrease the size of the snare loop assembly aperture to close the snare loop assembly. The free end of the snare may be manipulated in any suitable manner. In some variations, the snare may be attached directly to one or more portions of the handle, as will be described in more detail below. In other variations, a hypotube, rod, or other rigid structure may be attached to the free end of the snare. This structure may in turn be moved by the handle, which may help facilitate advancement or withdrawal of the snare through the elongate body.

[0048] In variations where one end of the snare is fixed relative to the closure device, the snare may be fixed to any suitable portion of the device. For example, in some variations one end of the snare may be fixedly held in, on, or near a tip of the elongate body. In other variations, the fixed end of the snare may be affixed in one or more lumens of the elongate body. In still other variations, the fixed end of snare may be at least temporarily attached to the device's handle. Although one end of the snare may be temporarily fixed relative to the closure device, it should be appreciated that this fixed end may be configured to be releasable and/or moveable. Configuring the fixed end of the snare to be releasable and/or movable may serve a number of useful functions. In some instances, temporary or permanent device failure may result in the moveable portion of the snare becoming stuck or caught. In these instances, it may be necessary to release the fixed end in order to allow the closure device to release ensnared tissue. In other instances, it may be desirable to move the free end in order to provide for adjustment of the snare using both ends.

[0049] When one end of the snare is configured to be temporarily fixed relative to the elongate body, the end of snare may be released from its fixed relation in any suitable manner. For

example, in some variations, an end of the snare may be temporarily held in a fixed manner by a frangible member. FIGS. 16A and 16B illustrate one variation by which an end of a snare (1600) may be releasably fixed to an elongate body (1602) by a frangible member (1604). Specifically, FIGS. 16A and 16B show a portion of elongate body (1602) having at least one lumen (1605). In this variation, a portion of lumen (1605) may be subdivided into at least first and second sub-lumens ((1606) and (1608) respectively). As shown in FIG. 16A, first sub-lumen (1606) has a first section (1610) with a first cross-sectional area, and a second section (1612) with a second cross-sectional area. The end of snare (1600) may be placed in first section (1610) of first sub-lumen (1606), and may be attached to the distal end of frangible member (1604), as shown in FIG. 16A. Frangible member (1604) may pass through second section (1612) of first sub-lumen (1606) and through lumen (1605).

[0050] The attachment of snare (1600) to frangible member (1604) may help temporarily lock the end of snare (1600) in place. The proximal end (not shown) of frangible member (1604) may be temporarily attached in a fixed manner to one or more portions of the device handle (not shown). Because the proximal end of the frangible member (1604) is held in place, the frangible member (1604) may prevent the snare from being pulled distally out of the end of the elongate body (1602). Additionally, the cross-sectional area of first section (1610) may be different from the cross-sectional area of the second section (1612) such that the end of snare (1600) is unable to pass from first section (1610) into second section (1612). In this way, the snare (1600) is prevented from moving proximally into the elongate body (1602). Additionally, in some variations, at least a portion of snare (1600) and first section (1610) may have non-circular cross sections (e.g., oval, triangle, square, polygon, or shape with irregular geometry) such that the snare (1600) housed within first section (1610) may be unable to rotate relative to first section (1610). Because the end of snare (1600) is prevented from moving proximally, distally, or rotating relative to first section (1610) of first sub-lumen (1606), the end of snare may be effectively immobilized relative to the elongate body (1602).

[0051] Frangible member (1604) may be configured such that application of a sufficient force to frangible member (1604) is sufficient to break the attachment between frangible member (1604) and snare (1600). To release snare (1600) from its fixed position, a user may pull on the proximal end of frangible member (1604) directly or indirectly (e.g., via one or more handle components). Because the snare (1600) is prevented from moving proximally into second section (1612), sufficient proximal force applied to the frangible member (1604) may act to

break the engagement between frangible member (1604) and snare (1600), thereby releasing the snare (1600) as shown in FIG. 16B.

[0052] The snares described here may be made of any suitable material or combination of materials. For example, in some variations the snare may be made from a shape-memory material, such as a shape-memory alloy (e.g., a nickel titanium alloy, etc.), or may be made from stainless steel, polyester, nylon, polyethylene, polypropylene, combinations thereof, and the like. In variations where the snare is made from the shape-memory material, the snare may be configured to take on a particular shape or configuration when the snare loop assembly is placed in an open configuration, but may still be at least partially withdrawn into the elongate body to place the snare loop assembly in a closed configuration. For example, as shown in FIG. 1 above, snare (102) may form a generally circular loop when snare loop assembly (100) is placed in an open configuration. While shown in FIG. 1 as being generally circular, snare (102) may form a loop of any given shape. FIGS. 17A-17D illustrate several additional snare configurations. In the variation shown in FIG. 17A, snare (1700) may form a teardrop-shaped loop (1702) when in a deployed configuration. In the variation shown in FIG. 17B, snare (1704) may form an oval or ellipsoid loop (1706) when in a deployed configuration. In the variation shown in FIG. 17C, snare (1708) may take on a substantially triangular loop (1709) when in a deployed configuration. Furthermore, in some variation, the snare loop may be angled relative to the elongate body. For example, FIG. 17D shows a side view of closure device (1710), in which snare (1712) exits elongate body (1714) that is at an angle (θ) relative to the elongate body's longitudinal axis (1716). This angle (θ) may be any suitable angle. For example, angle (θ) may be about 5°, about 15°, about 30°, about 45°, about 60°, about 75°, about 90°, between about 40° and about 50°, between about 35° and about 55°, between about 30° and about 60°, or the like. Angling snare (1712) relative to elongate body (1714) may aid the snare (1712) in capturing tissue, as angling may better position the snare (1712) relative to tissue as the closure device is moved in the body.

[0053] FIGS. 18A-18D illustrate yet another variation of snare (1800). In this variation, snare (1800) may form a hook-shaped loop (1802) when snare (1800) extends from elongate body (1804) in an open configuration. FIG. 18A shows a perspective view of snare (1800), while 18B shows a side view of snare (1800). Because the loop (1802) bends back over itself to form a hook shape (as highlighted in a side view in FIG. 18B), the snare (1800) may help create space between body tissues when in an open configuration. For example, when opened in the pericardial space, as shown in FIG. 18C, the snare (1800) may lift the pericardial sac (1806)

away from the heart (1808). Creating additional space within the pericardial sac may make it easier for snare (1800) to capture tissue, such as the left atrial appendage (1810), as shown in FIG. 18D.

Suture Loop

[0054] The snare loop assemblies described here may also comprise a suture loop for maintaining tissue in a closed manner. Generally, the suture loop may be releasably attached to the snare, for example, via a retention member, as will be described in more detail below. Furthermore, the suture loop may comprise a suture knot, but need not. This suture knot may be any suitable knot, including, but not limited to, a slip knot (e.g., a one-way slip knot). In some variations, as will be described in more detail below, at least a portion of the knot may be held within the tip of elongate body. In other variations, the suture knot may be temporarily held in fixed relation to the elongate body, as will be described in more detail below.

[0055] In variations where the suture loop comprises a slip knot, suture may be advanced or withdrawn through the slip knot to change the size of suture loop. In some instances where the suture knot is held within or against a tip of elongate body, the suture knot may not move while the size of suture loop is changed. This may help prevent the closure device from damaging tissue, as will be described in more detail below.

[0056] In some variations, the suture loop further comprises a unidirectional locking structure. In these variations, the unidirectional locking structure may be any structure capable of being advanced along the suture in one direction, but resisting movement in a second direction. In these variations, the locking structure may be advanced over a portion of the suture loop to help lock a suture knot in place. For example, in some variations the unidirectional locking structure may comprise a bead or mechanical structure which is placed at least partially around the suture. In these variations, the bead may comprise one or more teeth or projections that allow for the bead to be advanced along the suture in one direction, but prevents or resists movement in the opposite direction. The locking structure may be advanced via one of the closure devices described here, or may be advanced by a separate device after the suture loop has been released from the closure device.

[0057] Suture loop may be made from any suitable material useful in exclusion or closure. For example, it may be made of a biodegradable material (e.g., polylactic acid, polyglycolic

acid, polylactic-co-glycolic acid, etc.), or may be made of a non-biodegradable material (e.g., metal, steel, polyester, nylon, propylene, silk, combinations thereof and the like).

[0058] When the suture loop is tightened to close tissue, it may be possible for tissue to be pulled into the suture knot of the suture loop. If too much tissue is pulled into the suture knot, the suture knot may clog or jam in a way that prevents the suture loop from being further tightened. In some variations the suture loop may comprise one or more pledgets or tube sections to help shield a portion of the suture knot. FIGS. 19A-19G illustrate several variations of suture loops comprising knot-shielding elements. In FIG. 19A, two legs of suture loop (1900) are threaded through a pledget (1902). The pledget or pledgets used with the devices described herein may be made from any suitable material, such as, for example, polyurethane foam, felt, Teflon fabric, Dacron, collagen, or the like. FIG. 19B shows another variation of suture loop (1904) in which pledget (1905) is doubled over and two legs of suture loop (1904) are threaded therethrough. By increasing the thickness of pledget (1905) disposed between suture knot (1906) and tissue (not shown), the pledget (1905) may further reduce the amount of tissue that is pulled into suture knot (1906). FIG. 19C shows yet another variation of suture loop (1908) comprising pledget (1910), in which only a portion of pledget (1910) is doubled over. In this variation, one leg (1912) of suture loop (1908) may be threaded through the doubled-back portion of pledget (1910) while the other leg is threaded through the single-layered portion of pledget (1910).

[0059] FIG. 19D shows still another variation of suture loop (1914), in which one leg (1916) of suture loop (1914) and free end (1918) of suture loop (1914) are threaded through pledget (1920). FIG. 19E shows a variation of suture loop (1922) in which both legs and a free end (1924) of suture loop (1922) are all threaded through a pledget (1926). It should be appreciated that in some of these variations, one or more portions of pledget (1926) may be sized or otherwise configured to fit in one or more portions, lumens or recesses of the elongate body. FIG. 19F shows a variation of suture loop (1928) in which suture knot (1930) is at least partially shielded by tubing (1932). In this variation, the legs of suture loop (1928) may pass through the ends of tubing (1932), while suture knot (1930) may exit out of an aperture (1934) in the side of the tubing (1932). FIG. 19G shows another variation of suture loop (1936) in which the suture knot (not shown) is shielded by tubing (1938). In this variation, legs of suture loop (1936) may exit out of slots (1940) in the sides of tubing (1938), while the free end of suture loop (1936) may exit out of one end of the tubing (1938).

Retention Member

[0060] FIGS. 20A-20C depict illustrative retention members that may be used with the devices described herein. FIG. 20A shows an end view of a retention member (2014) having first and second lumens (2016, 2018) for retaining a closure element and a suture loop therein. In this variation, the second lumen (2018) has a slit or other opening (2020) along its length, for allowing the suture to pass therethrough when it is ready to be deployed. Of course, it should be understood that the first and second lumens may be positioned or oriented in any suitable way with respect to each other, and similarly, the slit or other opening on the second lumen may be positioned or oriented in any suitable fashion with respect to the first lumen (e.g., it may be approximately 180°, approximately 150°, approximately 120°, approximately 90°, approximately 60°, approximately 30°, or the like, from the first lumen (2016)). FIG. 20B provides an illustration of a retention member having a first lumen (2022), a second lumen (2024), and a slit (2026). In this variation, the slit (2026) is positioned closer to the first lumen (2022) than the slit of FIG. 20A. The width or spacing of the slit opening may be selected as desired or appropriate. Similarly, the slit need not extend or be continuous along the entire length of the retention member. In some variations, the slits may have prongs or arms along its length to help capture and retain the suture therein. In other variations, the slits may be covered at spaced apart locations therealong with a biodegradable polymer, temporarily used to tack or hold down the suture. Of course, in still other variations, the retention member does not comprise a slit, and instead comprises some other type of retention mechanism, such as the prongs or tacks described just above. In yet other variations, there are no slits or openings in the retention member and the suture loop is released upon removing or withdrawing the retention member and closing the device.

[0061] FIG. 20C provides another variation of a retention member. In this variation, the retention member has a first lumen (2028), second lumen (2030), and a separation region (2032). The separation region may be constructed in any suitable fashion. For example, the separation region may comprise a perforated region adapted to perforate and release the suture with the application of force. Alternatively, the separation region may be a thin-walled or other type of weakened region that may be configured to break and release the suture. It should be understood that the retention member may have any suitable geometry or shape, and may be made from any suitable material. Similarly, the lumens need not be full circles or have a circular cross-sectional geometry. When these or other types of retention members are used, the suture loop may be torn

out, pulled through, or otherwise released from the retention member after it has been properly positioned and tightened as desirable.

ELONGATE BODY

[0062] As mentioned briefly above, the elongate body of the closure devices described here may connect the distal end of the snare loop assembly and the handle or actuating mechanism while still allowing for control of the snare loop assembly through the elongate body. Specifically, at least a portion of some of the snare loop assembly components may be housed within elongate body, and may be connected to the handle through the elongate body. In some variations, at least a portion of the elongate body may be flexible, which may help facilitate navigation of the elongate body in and through tissue.

[0063] FIG. 21 shows one illustrative variation of an elongate body suitable for use with the closure devices described here. Shown there is elongate body (2100) attached to handle portion (2102). Elongate body (2100) may comprise tip portion (2103), curve (2104), first lumen (2106), second lumen (2108), and third lumen (2110). While shown in FIG. 21 as having a single curve (2104), elongate body (2100) may have no curves or may have multiple curves in different portions of the elongate body (2100). Furthermore, in some variations the closure device may comprise one or more mechanisms that may act or function to change the shape of the elongate body (2100). In instances where the elongate body (2100) comprises one or more curves (2104), a tube, mandrel or other straightening mechanism (not shown) may be used to temporarily straighten the elongate body. For example, a rigid tube or mandrel may be placed in one or more lumens of elongate body (2100), which may temporarily straighten any curved sections. Straightening may occur during delivery (e.g., when used in conjunction with a left atrial appendage ligation procedure, before the pericardial space is reached), and the straightening mechanism may be withdrawn at any point to allow elongate body (2100) to return to its original configuration. The straightening mechanism may be made of any suitable material (e.g., a rigid plastic, stainless steel, a combination thereof, etc.).

[0064] In other variations, one or more pre-curved tubes or mandrels may be inserted into elongate body (2100) to create one or more curved sections. In still other variations, one or more pull wires may be disposed in, on, or around elongate body (2100) and may cause elongate body (2100) to flex or bend when one or more of the pull wires is pulled, pushed or otherwise manipulated. It should be further understood that any of the devices described here may be

configured for steerability, or may be configured for robotic use (e.g., configured for use with one or more robotic or otherwise automated devices).

Lumens

[0065] The elongate bodies described here may have any suitable number of lumens. It should be appreciated that when the term “lumen” is used herein, it may be used to describe any bore or passageway extending through a length of the elongate body or other portion of the closure device. It should be appreciated that a lumen need not be entirely enclosed (i.e., the lumen may comprise one or more slots, slits, gaps or other openings along some or all of the length of the lumen). Elongate body may comprise one, two, three, four, or five or more lumens. Some or all of the lumens may extend entirely through the elongate body (i.e., from the proximal end of the elongate body to the distal end of the elongate body). Other lumens may pass through only a portion of the elongate body (e.g., from one end to an intermediate point along the elongate body, or between two intermediate points along the elongate body). For example, in the variation shown in FIG. 21, third lumen (2110) passes from the proximal end of the elongate body (2100) to an intermediate point along the length of the elongate body (2100). In this variation, one or more guidewires, visualization devices, or working devices (not shown) may be passed through third lumen (2110).

[0066] The various components of the snare loop assembly may be housed within any lumen or lumens of the elongate body. For example, in some variations, all components of the snare loop assembly may be housed in a single lumen. In other variations, different portions of the snare loop assembly may be at least partially housed in different lumens. For example, in some variations, the elongate body may comprise at least two lumens. In these variations, the free end of suture loop may pass to the handle portion through a first lumen, while the free end of the snare may pass to the handle portion through a second lumen. In variations where the suture loop has excess suture housed within the elongate body, as described in more detail below, this excess suture may be housed in any suitable lumen. For example, in some variations, the excess suture may be held in the same lumen as the free end of the suture loop, in the same lumen as the free end of the snare, or in an altogether different lumen.

[0067] In some instances, one or more of the lumens of the elongate body may be at least partially divided into one or more sub-lumens. Specifically, a lumen may be split into two or more sub-lumens along a portion of the length of that lumen. In some of these variations, a

piece of separation tubing may be used to divide a lumen into two or more sub-lumens. FIGS. 22A-22D illustrate several variations of separation tubing suitable for use with the closure devices described here. Specifically, FIGS. 22A and 22B show a perspective view and a top view, respectively, of one variation of separation tubing (2200). In this variation, separation tubing (2200) may comprise first (2202) and second (2204) lumens extending therethrough. When placed inside of a lumen of the elongate body (not shown), the first (2202) and second (2204) lumens of separation tubing (2200) may act as sub-lumens within the lumen of the elongate body. In this way, the separation tubing (2200) may allow for a lumen to be a single passageway along one length of the elongate body and two or more separate passageways along another length of the elongate body.

[0068] It should be appreciated that although shown in FIGS. 22A and 22B as having two lumens ((2202) and (2204)), separation tubing (2200) may include any suitable number of lumens (e.g., one, two, three, or four or more). In this way, a lumen of the elongate body may be subdivided into any suitable number of sub-lumens along the length of the separation tubing. It should be noted that in some variations, the separation tubing may only have a single lumen passing therethrough. In these variations, the separation tubing may not divide a lumen into multiple sub-lumens, but instead may alter the size and/or shape of the lumen along a portion thereof. It should also be appreciated that some or all of the lumens of the separation tubing (2200) may only pass through a portion of the separation tubing.

[0069] In other variations, a piece of separation tubing may include one or more grooves or channels. These grooves or channels may form a fully-enclosed sub-lumen when placed inside of a lumen of an elongate body. For example, FIGS. 22C and 22D illustrate one such variation of separation tubing (2206). Specifically, FIG. 22C shows a perspective view of separation tubing (2206), which comprises lumen (2208) and channel (2210) along an outer surface of separation tubing (2206). When separation tubing (2206) is placed inside of a lumen (2211) of an elongate body (2212), as shown in a top view in FIG. 22D, channel (2210) may form an enclosed lumen which may be defined in part by the separation tubing (2206) and in part by the lumen wall. It should be appreciated that the separation tubing described here may comprise any suitable number and combination of channels and/or lumens.

[0070] In some variations it may be desirable to configure the separation tubing to allow one or more components of the snare loop assembly to be released therethrough. For example, in some instances a portion of the snare loop may be threaded through two or more lumens/channels of a

section of separation tubing, as will be described in more detail below. In order to release the suture loop from the device, it may be necessary to remove any excess suture from separation tubing without undoing or breaking the suture loop. Thus, in some variations, the separation tubing may comprise one or more separation regions (not shown) between two or more lumens, channels, or combinations thereof. The separation regions may be constructed in any suitable manner, such as those described above with respect to the retention members. For example, in some variations the separation region may comprise a perforated region adapted to perforate and allow suture to pull therethrough as the suture loop is tightened. Alternatively, in some variations the separation region may be a thin-walled or other type of weakened region that may be configured to tear or otherwise break upon the application of force from a suture or other device component.

Tips

[0071] The elongate body generally comprises a tip portion at the distal end thereof. In some variations, the tip of the elongate body may be formed separately from the elongate body, and may be attached to the body during assembly of the device. In other variations the tip portion may be formed integrally with the elongate body as a unitary device. The tip portion may serve a number of useful functions for closure device. In some instances, the tip may be configured to be atraumatic, which may act to reduce the risk of damaging tissue as the proximal end of the elongate body is moved within the body. In other instances, the tip may allow certain portions of the snare to pass through elongate body while holding other portions in place relative to elongate body, as will be described in more detail below.

[0072] The tip portion may have the same number of lumens as the elongate body, but need not. Indeed, in some variations, the tip portion may divide one or more lumens of the elongate body into two or more sub-lumens. In some of these variations, the tip portion may house at least one portion of a piece of separation tubing. In other variations, the tip portion may alter the size or shape of one or more lumens of the elongate body.

[0073] FIGS. 23A-23C show the distal end of one illustrative variation of closure device (2300). Specifically, FIG. 23A shows a front view of tip (2302) of elongate body (2304). As can be seen there, tip (2302) may comprise first sub-lumen (2305), second sub-lumen (2306), and third sub-lumen (2308). FIG. 23B shows a cross-sectional side view of elongate body (2304) and tip (2302). As shown there, first (2305) and second (2306) sub-lumens may exit into

a first lumen (2310) of elongate body, while third sub-lumen may exit into a second lumen (2312).

[0074] In some variations, one sub-lumen may be configured to at least partially house a suture knot of the suture loop. For example, second sub-lumen (2306) shown in FIG. 23B may comprise a knot-receiving recess (2316) with a first cross-sectional area, and a second section (2318) with a second cross-sectional area. A suture knot (2320) of a suture loop (2330) may be placed in knot-receiving recess (2316) of second sub-lumen (2306), as shown in FIG. 23C. A free end of suture loop (2330) may pass through second section (2318) into first lumen (2310) of elongate body (2304). Additionally, the cross-sectional area of knot-receiving recess section (2316) may be different (e.g., smaller and/or differently shaped) from the cross-sectional area of the second section (2318) such that the suture knot (2320) is unable to pass from knot-receiving recess section (2316) into second section (2318). In this way, the suture knot (2320) may be prevented from moving proximally into the elongate body (2304). Additionally, because suture knot (2320) may be housed at least partially in the knot-receiving recess (2316) of second sub-lumen (2306), suture knot may be prevented from pulling into third sub-lumen (2308) when excess suture is pulled into elongate body (2304), as will be described in more detail below.

[0075] FIG. 23C also illustrates how other components of a snare loop assembly (2324) may be disposed relative to tip (2302). As shown there, snare loop assembly (2324) may comprise snare (2326), suture loop (2330), and retention member (2328). Retention member (2328) may releasably connect a portion of snare (2326) and suture loop (2330). A free end of suture loop (2330) may pass through second sub-lumen (2306) and first lumen (2310) to a handle portion (not shown), while an amount of excess suture (2330) may be housed within third-sub lumen (2308) of tip and second lumen (2312) of elongate body. At least a portion of this excess suture (2330) may be held within the elongate body by one or more suture management features (not shown) described below. Additionally, one end of snare may be fixed, temporarily or permanently, at least partially within first sub-lumen (2305), while a free end of snare (2326) may be moved at least partially through third sub-lumen (2308) of tip and second lumen (2312) of elongate to open and close the snare loop assembly (2324).

[0076] In variations where the tip of an elongate body comprises a knot-receiving recess, it may be desirable to eject or move the suture knot from the recess during or prior to tightening of the suture loop. Moving a suture knot out of the recess may improve the ability of the suture loop to tighten around tissue by improving knot placement relative to tissue. A suture knot may

be displaced from the recess in any suitable manner. For example, FIGS. 24A and 24B illustrate two suitable variations by which a suture knot may be advanced from a knot-receiving recess. In a first variation, closure device (2400) may comprise a balloon (2402) or other expandable structure disposed in a knot-receiving recess (2406), as illustrated in FIG. 24A. Suture knot (2408) of suture loop (2410) may be at least partially housed in knot-receiving recess (2406) when balloon is collapsed. When balloon (2402) is expanded, it may displace at least a portion of suture knot (2408) from the knot-receiving recess (2406). In another variation, closure device (2412) may comprise a pusher (2414) at least partially disposed in a knot-receiving recess (2416), as shown in FIG. 24B. In this variation, pusher (2414) may be advanced within knot-receiving recess (2416) to push at least a portion of suture knot (2418), and in some instances the entire suture knot (2418), from the knot-receiving recess (2416).

[0077] In other variations of the closure devices described here, the tip portion may comprise a distal recess. FIGS. 25A-25D illustrate one such variation of tip (2500). FIG. 25A-25C show a perspective view, a front view, and a cross-sectional side view of tip (2500). Shown there is proximal recess (2502) for receiving a distal end of the elongate body (not shown), distal recess (2504), first sub-lumen (2506), second sub-lumen (2508), and third sub-lumen (2510). While shown in FIGS. 25A-25C as being formed separately from the elongate body, it should be appreciated that the tip may be formed integrally with the elongate body.

[0078] FIG. 25D illustrates a cross-sectional side view of one instance of how tip (2500) may be incorporated into a closure device (2512). Shown there is tip (2500) attached to elongate body (2514). As shown there, elongate body (2514) may comprise a first lumen (2516) and a second lumen (2518), and may be placed within the proximal recess (2502) of tip (2500). First (2506) and second (2508) sub-lumens may exit into first lumen (2516), while third sub-lumen may exit into second lumen (2518).

[0079] Closure device (2512) may further comprise separation tubing (2520) that may be disposed partially in third sub-lumen (2510) of tip (2500) and second lumen (2518) of elongate body (2514), and may divide the lumen into sub-lumens (2522) and (2524). Also shown in FIG. 25D is snare loop assembly (2526) comprising snare (2528), suture loop (2530), and retention member (2532). One end (2534) of snare (2528) may be fixedly attached to tip (2500) via first sub-lumen (2506) or may be attached in lumen (2516) through sub-lumen (2506), while a free end of the snare may be advanced or withdrawn through sub-lumen (2524) of separation tubing (2520). Similarly, a free end (2536) of suture loop (2530) may pass through second sub-lumen

(2508) of tip (2500), while a portion of excess suture of suture loop (2530) may be housed in sub-lumens (2522) and (2524) of separation tubing (2520).

[0080] Suture knot (2538) may be housed in distal recess (2504). Additionally, second sub-lumen (2508) of tip (2500) and sub-lumen (2522) of separation tubing (2520) may be sized such that suture knot (2538) is unable to pass into either sub-lumen, thereby preventing suture knot (2538) from being pulled or pushed into the elongate body (2514). Additionally, by placing the ends of the suture knots against the entrances to these sub-lumens, the suture loop (2530) may be tightened around tissue while minimizing the amount of tissue that may be pulled into suture knot (2538) as the suture loop (2530) is tightened.

EXCESS-SUTURE MANAGEMENT

[0081] In operation of the closure devices, it may be desirable to be able to open and close a snare loop assembly without prematurely releasing the suture loop from the snare assembly. Because the size of the continuous aperture defined by the snare loop assembly changes as the snare loop assembly is opened and closed, it may be necessary for the size of the suture loop to change in order to accommodate this change in aperture size and to prevent the suture from being prematurely released from the snare loop assembly. In some variations, opening the snare loop assembly may pull suture through a slip knot to increase the size of the suture loop. This may, however, provide sufficient force to the suture loop to cause the suture to break or sever. To help prevent this undesirable outcome, the suture loop may be sized such that the suture loop is as large as or larger than the size of the aperture defined by the snare loop assembly when the snare loop assembly is in an open configuration. Thus, when the snare loop assembly is opened to a deployed configuration, the suture loop can assume a similar size without needing to advance additional suture through the suture knot. Pre-sizing the suture loop to such a size, however, may result in extra slack in the suture loop when the snare loop assembly is in a closed configuration. To help prevent the excess suture from getting entangled with or caught on anatomical structures, instruments, or other obstructions, some or all of the slack in the suture loop may be held inside of the elongate body when the snare loop assembly is opened and/or closed.

[0082] As such, the closure devices described here may comprise one or more excess-suture management features, which may be used in any suitable manner. In some instances, the feature may be configured to apply a force to the excess suture when the device is an open and/or a

closed configuration. This force may act to pull the excess suture into the elongate body or may temporarily prevent excess suture from exiting the elongate body. Additionally, this force may act to prevent the excess suture from knotting or bunching up, which may potentially affect device performance. The following is a discussion of a number of different potential suture management features suitable for use for the closure devices described here. It should be appreciated that the closure devices described here may comprise any combination of these suture management features.

Suture Hooks

[0083] In some variations, a suture hook may be used to hold the excess suture within the elongate body. FIG. 2 shows one such variation of a snare loop assembly (200) having suture hook (202). Also shown there is snare (204), suture loop (206) having suture knot (208), and retention member (210). As illustrated in FIG. 2, suture hook (202) may hold excess suture from suture loop (206) within an elongate body (not shown). In variations in which the elongate body has multiple lumens, suture hook (202) may hold excess suture in any suitable lumen.

[0084] In some variations the proximal end of the suture hook may be able to move relative to the elongate body when snare is advanced from or withdrawn through or within the elongate body. FIG. 10 shows a cross-sectional side view of a portion of closure device (1000) comprising elongate body (1002) with lumen (1004) disposed therethrough, and connected to interconnect (1006) of a handle (not shown). It should be appreciated that, although shown in FIG. 10 as having only one lumen (1004) disposed therethrough, elongate body (1002) may have any number and configuration of lumens as described above. Also shown in FIG. 10 is a portion of snare (1008) attached to hypotube (1009) and suture hook (1010) engaging a portion of suture loop (1012). As described above, snare (1008) may be advanced or withdrawn through or within elongate body (1002) to open or close a snare loop assembly (not shown).

[0085] When snare (1008) is advanced and snare loop assembly is opened, suture loop (1012) may pull suture hook (1010) toward the distal end of the elongate body (1002) to release some of the excess suture from the elongate body (1002) or to allow some of the excess suture to advance within the elongate body (1002). In some variations, suture hook (1010) comprises a spring (1014). Spring (1014) may stretch when suture hook (1010) moves toward the distal end of the elongate body (1002). Conversely, closing the snare loop assembly may reduce the force applied to suture hook (1010) by suture loop (1012), which may allow the return force of the

spring (1014) to pull suture hook (1010) proximally. This, in turn, may pull any excess suture back into or through a portion of elongate body (1002). Because excess suture is released from elongate body (1002) when the snare loop assembly is opened and withdrawn into elongate body (1002) when snare loop assembly is closed, the suture loop (1012) may be maintained at the same size as the snare loop assembly. Additionally, because the excess suture is doubled back into the elongate body when held by suture hook (1010), suture hook (1010) need only to be configured to move half as much as snare (1008) in order to maintain the suture loop (1012) at the same size as snare loop assembly.

[0086] It should be appreciated that although shown in FIG. 10 as having one end attached to suture hook (1010) and the other end attached to interconnect (1006) (which will be described in more detail below), spring (1014) may be attached to any suitable portion or portions of the closure device (1000). In some variations, the spring may be attached to one or more elements of the handle, as will be described in more detail below. In other variations, the spring may be attached to one or more portion of the elongate body (1002). In still other variations, suture hook (1010) does not comprise a spring at all. In some of these variations, at least a portion of the suture hook (1010) may be capable of stretching or otherwise deforming to allow excess suture to be pulled out of elongate body (1002). For example, suture hook (1010) may comprise an elastic material or combination of materials that are capable of both stretching and returning to an unstretched state. In these instances, as snare loop assembly opens, the elastic material or materials may stretch to allow excess suture to be pulled out of or through a portion of elongate body (1002). When snare loop assembly is closed, the suture hook (1010) may return to its unstretched state, and may thereby pull the excess suture back into or through a portion of the elongate body (1002).

[0087] In variations where excess suture from suture loop (1012) is held within the elongate body by suture hook (1010), an additional step may be required to release suture loop (1012) from snare loop assembly. Once snare loop assembly is advanced over a target tissue and closed over the tissue, there may be excess suture from suture loop (1012) held in the elongate body by suture hook (1010). Before suture loop (1012) can be released from the snare loop assembly, this slack may first need to be removed. To achieve this, the excess suture may be pulled through a suture knot (not shown) to reduce the size of suture loop (1012). In some variations, suture hook (1010) may be configured to deform once sufficient force is applied thereto. Furthermore, in some variations suture hook (1010) comprises a stop (1016) that prevents suture hook (1010) from moving distally beyond a certain point. Thus, as suture is withdrawn through

suture knot and the size of suture loop (1012) decreases, suture loop (1012) places an increasing force on suture hook (1010). Suture hook (1010) may move toward the distal end the elongate body (1002) until stop (1016) engages interconnect (1006). It should be noted that stop (1016) may engage any suitable structure in closure device (1000). When stop (1016) engages interconnect (1006), suture hook (1010) is held in place and eventually the force applied by suture loop (1012) may cause the end of suture hook (1010) to deform and release the remaining excess suture.

[0088] After suture loop (1012) has been released from suture hook (1010) and the excess suture has been removed from suture loop (1012), any additional suture that is pulled through suture knot may begin to release suture loop (1012) from the snare loop assembly. If the snare loop assembly is closed around tissue before releasing suture loop (1012), any excess suture may be held within the elongate body (1002). Thus, any excess suture removed from the suture loop (1012) is housed within the elongate body (1002). Because this suture is housed within the elongate body (1002), it will not rub against or otherwise make contact with tissue disposed outside of the elongate body (1002). Additionally, as the suture loop (1012) is released from the snare loop assembly, the suture is released directly into contact with the tissue. Thus, a user may both remove excess suture from the suture loop (1012) and release the suture loop (1012) from the snare loop assembly without rubbing or sliding against the tissue. Because tissue may be damaged when suture slides or rubs against tissue, the closure devices described here may help minimize damage caused to tissue in this way. Once the suture loop (1012) is completely separated from the snare loop assembly, it may be tightened to ligate the target tissue.

[0089] As shown in FIG. 10, snare (1008) and suture hook (1010) may be disposed in the same lumen (1004) of elongate body (1002), but need not be. In variations where the snare (1008) is disposed in the same lumen (1004) as suture hook (1010), there may be a risk of the snare (1008) becoming entangled with the suture hook (1010). Additionally, because the suture hook (1010) need only move half as much as snare (1008) when opening and closing the snare loop assembly, the snare (1008) may rub against spring (1014), which may in turn cause spring (1014) to rub against the inner wall of lumen (1004). This friction may impede the actuation of the closure device (1000), and thus increase the force a user must provide to actuate the device.

[0090] In some variations, the closure device may be configured to help prevent the suture hook from tangling with the snare. FIG. 11 shows one such variation of a middle portion of closure device (1100). Shown there is elongate body (1102) attached to interconnect (1104),

hypotube (1106), snare (1108), spring (1110), suture hook (1112), sleeve (1114), and suture loop (1116). The free end of snare (1108) may be attached to hypotube (1106), as described above. Additionally, suture hook (1112) may be attached to hypotube (1106) via spring (1110). Spring (1110) may additionally be disposed around snare (1108), which may help prevent spring (1110) from tangling with snare (1108). Additionally, this may reduce the amount of space taken up by snare (1108) and spring (1110), which may, in turn, allow snare and spring to be placed within a smaller lumen without adding to the amount of rubbing that occurs between the spring and the inner wall of lumen.

[0091] Sleeve (1114) may also act to help prevent tangling between suture hook (1112) and snare (1108). Sleeve (1114) may have two or more lumens. Suture hook (1112) may pass through one lumen, while snare (1108) may pass through a separate lumen. In some variations, sleeve (1114) may be attached to snare (1108). Sleeve (1114) may be attached in any suitable manner (e.g., bonding, welding, mechanical attachment, etc.). In these variations, sleeve (1114) may act as a stop to help release suture loop (1116) from suture hook (1112). As excess suture is removed from suture loop (1116), as described above, spring (1110) may stretch until it comes into contact with sleeve (1114). Once in contact with sleeve, spring (1110) may be held in place while the force exerted on suture hook (1112) by suture loop (1116) may cause suture hook (1112) to deform, and may thereby release suture loop (1116) from suture hook (1112).

Separation Tubing

[0092] In some instances it may be desirable to maintain excess suture within the elongate body without the need for a suture hook. Under certain circumstances, as a portion of the elongate body is advanced into or through the body, one or more portions of the elongate body may bend or flex to allow the snare loop assembly to reach a target location. Bending or flexing the elongate body, however, may impede movement of the suture hook or spring, which may potentially impede the snare hook's ability to maintain excess suture loop within the elongate body. Thus, it may be desirable to have a suture maintenance feature that is located in a distal portion of the elongate body.

[0093] As such, in some variations of the closure devices described here, one or more pieces of separation tubing may be used to help maintain excess suture within the elongate body, and may thereby limit the exposure or release of excess suture out of the elongate body. FIGS. 26A and 26B show cross-sectional side views one such variation of a closure device (2600). Shown

there is lumen (2602) with separation tubing (2604) disposed therein. Separation tubing (2604) may divide lumen (2602) into a first sub-lumen (2606) and a second sub-lumen (2608). Closure device (2600) may comprise a snare loop assembly (2610), which may comprise snare (2612), suture loop (2614), and retention member (2616). As shown in FIGS. 26A and 26B, suture from suture loop (2614) may pass through first sub-lumen (2606) into lumen (2602), where it may be connected to snare (2612) via retention member (2616). Snare (2612) may be advanced or withdrawn through second sub-lumen (2608) to open or close the snare loop assembly, respectively. When snare loop assembly (2610) is in a closed configuration, as shown in FIG. 26A, excess suture from suture loop (2614) may be held in snare lumen (2602) and first sub-lumen (2606). When snare is advanced to open the snare loop assembly, some of the suture held within the snare lumen may be advanced into the second sub-lumen (2608) to allow the snare loop assembly to open, as shown in FIG. 26B. The presence of separation tubing, however, may prevent the excess suture from being pushed or pulled out of the tip of the closure device.

[0094] When separation tubing is employed to maintain excess suture within elongate body, it may be necessary for the separation tubing to comprise one or more separation regions to release the excess suture from the elongate body. These separation regions, as described in more detail above, may allow suture to pass therethrough during release of the suture loop. Specifically, as excess suture is removed from the suture loop (i.e., as suture is pulled through the suture knot to tighten the suture loop), the suture may be pulled through the separation regions, allowing the excess suture to span the space between the sub-lumens of the separation tubing.

[0095] It should be appreciated that any suitable piece of separation tubing as described in more detail above may be used to maintain excess suture within the elongate body. It should also be appreciated that separation tubing may be used in conjunction with a suture hook, as described above, or one or more additional excess-suture management features. For example, in some instances separation tubing may be used in conjunction with one or more suture tubes. Generally, a suture tube has a first end that may be connected to the separation tubing, a second end that may be connected to a portion of the snare loop assembly, and may temporarily hold excess suture therein. The suture tube may be made from any suitable material (e.g., Pebax, Tecothane, nylon, or the like), and may comprise one or more separation regions which may allow the excess suture to be removed from the suture tube.

[0096] FIG. 27 shows a partial cutaway view of one such variation of a closure device (2702) comprising elongate body (2701), separation tubing (2704) and a suture tube (2705). Shown

there is separation tubing (2704), which divides lumen (2700) into first sub-lumen (2706) and second sub-lumen (2708). Also shown there is snare loop assembly comprising snare (2712), suture loop (2714), and retention member (2716) at least temporarily connecting snare (2712) and suture loop (2714). As shown in FIG. 27, suture tube (2705) may releasably house a portion of suture loop (2714). One end of suture tube (2705) may be attached to the separation tubing (2704), and the other end may be attached to a portion of the snare loop assembly (e.g., attached to snare (2712) or retention member (2716)). By virtue of this attachment, one end of the suture tube (2705) may be fixed relative to the closure device (2702) while the other end may move with snare (2712) and closure element (2716) as the snare loop assembly is moved between a closed configuration and an open configuration.

[0097] When placed in lumen (2700), suture tube (2705) may double back upon itself at bend (2718). In this way, the portion of suture loop (2714) temporarily housed in suture tube (2705) may be held in the doubled-back suture tube (2705), which may help prevent the excess suture held within lumen (2700) from bunching. The position of bend (2718) may move as the snare loop assembly is changed between opened and closed configurations. Additionally, in some instances the suture tube (2705) may have a tendency to return to an unbent shape, which may also give the suture tube (2705) tendency to twist and kink at points other than bend (2718). As such, suture tube may comprise one or more features that may help reduce twisting or kinking. For example, in some variations, tube comprises a plurality of cut or slits that may act as relief areas. FIGS. 28A and 28B show one such variation of suture tube (2800). FIG. 28A shows suture tube (2800) comprising v-shaped cuts (2802) along one side thereof. Each v-grooved cut (2802) reduces the rigidity of suture tube (2800) along that side, and may make the suture tube (2800) more likely to bend or flex at that cut (2802). Thus, when suture tube (2800) is placed within a lumen (2804), as shown in FIG. 28B, and doubles back at bend (2806), some of the v-shaped cuts (2802) may be essentially closed. As such, the v-shaped cuts (2802) may reduce the straightening force of the suture tube (2800), and may thereby alter the tendency of the suture tube (2800) to kink or twist. While shown in FIGS. 28A and 28B as being v-shaped, the cuts may be any suitable shape (e.g. semi-circular, semi-oval, etc.).

[0098] In other variations, the suture tube may comprise one or more strengthening members that may affect the rigidity of one or more portions of the suture tube. FIG. 29 illustrates a cross-sectional view of one such variation of suture tube (2900). Shown there is suture tube (2900), comprising suture lumen (2902), two strengthening members (2904), and separation region (2906). The strengthening members (2904) provide extra rigidity to a portion of the

suture tube (2900). As such, when suture tube (2900) is doubled-over for placement in a snare lumen, the side of suture tube (2900) containing the strengthening member (2904) will have more resistance to bending, which may allow suture tube (2900) to better resist twisting and kinking. Additionally, strengthening members (2904) may increase the column strength of the suture tube (2900), such that the tube may be more easily moved as the snare is advanced or retracted. Strengthening members may be any suitable structures, such as, for example a wire made from a nickel titanium alloy, steel, a polymer, or the like. While shown in FIG. 29 as having two strengthening members (2904), it should be appreciated that the suture tube may comprise any suitable number of strengthening members (e.g., one, two, or three or more)

Pulley Suture

[0099] In still other variations, the snare loop assembly may comprise a second suture, a pulley suture, that may engage a portion of the suture loop to help hold excess suture. Generally, one end of the pulley suture may be fixedly attached to a portion of the closure device (e.g., the handle or the elongate body) while the other end may be temporarily or permanently attached to the snare loop assembly. In some variations, the body of the pulley suture may be looped around or doubled back over a portion of suture loop to help hold a portion of the suture loop in the elongate body. FIGS. 30A-30D depict one variation of closure device (3000) comprising a pulley suture (3002) that may be used to hold a portion of a suture loop (3010) within a lumen (3004) of an elongate body (3006). Shown in FIG. 30A is snare loop assembly (3008) comprising suture loop (3010), snare (3012), retention member (3014), first suture lock (3016), second suture lock (3018), first separation tubing (3020), and second separation tubing (3022). While shown in FIG. 30A as having first (3020) and second (3022) separation tubing segments, closure device (3000) may comprise any number of separation tubing segments (e.g., zero, one, two, or three or more). Additionally, for clarity's sake first (3020) and second (3022) separation tubing segments are not shown in FIGS. 30B and 30C.

[0100] As mentioned above, one end (not shown) of pulley suture (3002) may be fixedly attached to a portion of the handle (e.g., a suture fob, as will be described in more detail below) while the other end may be temporarily attached to snare (3012) via second suture lock (3018) (suture locks will be described in more detail below). Pulley suture (3002) may also be doubled-back over a portion of suture loop (3010) between knot (3024) and second suture lock (3018), as shown in FIGS. 30A-30C. This engagement may allow excess suture to be advanced through elongate body (3006) when snare (3008) is advanced (as shown in FIG. 30B), while pulling

excess suture distally into elongate body when snare (3008) is retracted (as shown in FIG. 30C). Because both suture loop (3010) and pulley suture (3002) are each temporarily attached to snare (3008) (by virtue of first (3016) and second (3018) suture locks, respectively), the sutures may be moved the same distance when snare (3008) is moved. This movement may also advance or retract the point of overlap between the two sutures when the snare is advanced or retracted, respectively.

[0101] In order to release the suture loop (3010) from the closure device (3000), it may be necessary to terminate the engagement between the pulley suture (3002) and suture loop (3010). This engagement may be terminated in any manner. In some variations the pulley suture may be released from suture lock and removed from the elongate body by pulling on one end of the pulley suture (3002). Indeed, pulley suture (3002) may be configured to pull out of or otherwise separate from the second suture lock (3018) upon application of a certain force to the pulley suture. As shown in FIGS. 30A-30C, pulley suture (3002) may double back as it enters second suture lock (3018). This may help release pulley suture (3002) from second suture lock (3018) as the change in direction may increase the shear force applied by the pulley suture (3002) to the second suture lock (3018). Additionally, first suture lock (3016) may be configured to release suture loop (3010) when a certain force is applied to the suture loop. To help prevent premature release of the suture loop (3010) from retention member (3014), the closure device (3000) may be configured such that the release force for the second suture lock (3018) is less than the release force for the first suture lock (3016), but need not be.

[0102] In order to release pulley suture (3002) from snare (3008), one end of pulley suture (3002) may be attached to one or more portions of the device's handle. For example, FIG. 30D shows one variation of a portion of handle (3024) of closure device (3000). As shown there, an end of pulley suture (3002) and an end of suture loop (3010) may be attached to suture fob (3026). While shown in FIG. 30D as attached to the same suture fob, it should be appreciated that pulley suture (3002) and suture loop (3010) need not be attached to the same handle component. In variations where the pulley suture (3002) and the suture loop (3010) are attached to the same handle component, such as the variation shown in FIG. 30D, the suture loop (3010) may comprise slack/excess suture inside of the handle (3024). Thus, when suture fob (3026) is pulled away from handle (3024), the pulley suture (3002) may be placed under tension before the suture loop (3010) is placed under tension. In this way, as the suture fob (3026) is pulled, the closure device (3000) may be configured to release the pulley suture (3002) from second snare lock (3018) prior to tightening and releasing the suture loop (3010).

[0103] FIG. 15 shows another variation of closure device (1502) comprising a pulley suture (1504). In this variation, pulley suture (1504) may be releasably connected to suture loop (1506) via deformable link (1508). One end of pulley suture (1504) may be attached to snare (1510) via first suture lock (1512), while the other end of the pulley suture (1504) may be fixedly attached to any suitable portion of the device (e.g., one or more portions of the handle or the elongate body). As in the other variations described above, pulley suture (1504) may be advanced or withdrawn with snare (1510) to help hold a portion of the suture loop (1506) inside of elongate body (1514).

[0104] To release the engagement between pulley suture (1504) and the suture loop (1506), the suture loop (1506) may be pulled away from the pulley suture (1504). This may be done in any suitable manner, such as, for example, tightening the suture loop (1506) or pulling one end of pulley suture (1504) relative to the suture loop (1506). As the suture loop (1506) and pulley suture (1504) are pulled away from each other, the two sutures may apply one or more forces to the deformable link (1508). These forces may cause the deformable link (1508) to deform, which may release the engagement between the suture loop (1506) and pulley suture (1504).

FORCE REDUCTION

[0105] In some instances, when a suture hook or other suture maintenance feature pulls and holds excess suture in an elongate body, it may exert one or more forces on the suture loop. This force applied to the suture loop may, in some instances, cause the suture loop to prematurely disengage from the snare loop assembly. This is illustrated in FIG. 12. Shown there is the distal end of closure device (1200) comprising snare loop assembly (1202) and suture hook (1204). Snare loop assembly comprises suture loop (1206) with suture knot (1208) and releasably coupled to snare (1210) via retention member (1212). When suture loop (1206) is pulled into an elongate body (not shown) by suture hook (1204), suture hook (1204) may place one or more tensile forces (1214) on the suture of suture loop (1206). These tensile forces may be translated into inwardly directed forces (1216) in the portion of suture loop (1206) disposed within snare loop assembly (1202). These inwardly directed forces (1216) may cause suture loop (1206) to disengage the suture loop (1206) from the retention member (1212), thereby releasing suture loop (1206) from snare loop assembly (1202) prematurely.

[0106] In order to prevent this problem, the snare loop assembly may comprise one or more suture locks. FIGS. 13A-13C illustrate one such variation of a closure device (1300). FIG. 13A

shows a cross-sectional side view of closure device (1300) comprising snare loop assembly (1302), suture hook (1304), and suture lock (1306). Snare loop assembly (1302) may comprise suture loop (1308) with suture knot (1310) and coupled to snare (1312) via retention member (1314). FIG. 13B shows a front view of suture lock (1306). Shown there is suture lock (1306) comprising first lumen (1316), second lumen (1318), and slit (1320). Generally, at least a portion of snare (1312) may pass through first lumen (1316), while at least a portion of suture loop (1308) may pass through second lumen (1318). In some variations, force-reducing element (1306) may be attached to snare (1312) via first lumen (1316).

[0107] Generally, second lumen (1318) of force-reducing element (1306) may be configured to compress at least a portion of suture loop (1308). Because suture generally comprises a braided material disposed around a strength member, portions of a suture may be compressed without significantly affecting its strength. Second lumen (1318) may have a cross-sectional area that is smaller than the cross-sectional area of the suture. Thus, a portion of suture loop (1308) may be advanced through or otherwise placed in the second lumen (1318), and the narrow cross-sectional area of second lumen (1318) may act to compress the portion of suture loop (1308) disposed within second lumen, as shown in FIG. 13C. The compressed portion of suture loop (1308) may cause the suture loop (1308) to resist being pulled or pushed through force-reducing element (1306). More specifically, the uncompressed portions of suture loop (1308) may abut against the outer surface of the force-reducing element, and this abutment may resist movement of suture through the second lumen (1318).

[0108] Compression of a portion of suture loop (1308) may help prevent suture loop (1308) from prematurely releasing from snare loop assembly (1302). As described above with respect to FIG. 12, tensile forces placed on a suture loop may be translated into one or more forces that may cause a suture loop to disengage from a snare loop assembly. A force-reducing suture lock (1306) may help reduce or eliminate the forces applied to the portion of suture loop held by snare loop assembly (1302). More specifically, the compression of the portion of suture loop (1308) disposed within second lumen (1318) may prevent or reduce the transmission of the tensile force through force-reducing element (1306). As noted above, the compression of suture loop (1308) may cause the suture loop (1308) to resist movement through force-reducing element (1306). Thus, when suture hook (1304) applies a tensile force to suture loop (1308), as described above, this tensile force may attempt to pull suture through force-reducing suture lock (1306), but any such movement is resisted by the compression caused by force-reducing element (1306). As a result, some or all of the tensile force is, in effect, dissipated by trying to pull

suture through force-reducing suture lock. This, in turn, may reduce or completely remove any force experienced by the suture on the other side of force-reducing element. Thus, force-reducing suture lock (1306) may reduce or remove the forces that may cause the suture loop (1308) to prematurely release from the snare loop assembly (1302).

[0109] Force-reducing suture lock (1306) may comprise one or more slits (1320) or other openings. These slits may allow suture loop (1308) to pass therethrough when it is ready to be deployed. These slits may have any suitable configuration, such as those described in U.S. Patent Application No. 12/055,213. Generally, once suture loop (1308) is tightened to remove excess suture from suture loop (1308), the suture loop (1308) may be tightened further, which may cause a portion of the suture loop (1308) to pass through the slit or other opening. As suture passes through the slit, suture loop (1308) may be released from force-reducing suture lock (1306).

[0110] In some variations, a force-reducing suture lock may be made from one or more pieces of shrink tubing. In these variations, a portion of the snare and the suture loop may be threaded through one or more lumens of the shrink tubing. One or more stimuli (e.g., heat) may be applied to the shrink tubing, which may cause the shrink tubing to get smaller. This reduction in size may act to hold and connect suture loop and snare.

HANDLES

[0111] Handles or proximal controls that are capable of facilitating removal of excess suture from a suture loop and releases of suture loop from snare loop assembly are provided. Handles having one or more ergonomic features or configurations to help facilitate and improve the use thereof are also described herein. FIGS. 3A and 3B show a perspective view and a cross-sectional side view, respectively, of one suitable variation of handle (300). FIG. 3A shows a perspective view of handle (300) attached to elongate body (302). Also shown there is strain relief portion (304), snare lock (306), snare control (308), suture fob (310), and guidewire introducer (312). FIG. 3B shows a cross-sectional bottom view of handle (300). Also shown there is interconnect (314), locking collar (316), suture (318) and snare (320). Generally, suture (318) may be attached to suture fob (310), which may be pulled away from the handle. Pulling suture fob (310) may tighten the suture loop (not shown), and this tightening may pull excess slack from the suture loop. Once any excess slack has been removed from the suture loop, a user may continue to tighten the suture loop to release the suture loop from the snare loop

assembly (not shown). Similarly, snare (320) may be attached to snare control (308), which may in turn be used to control a snare and/or a snare loop assembly. As snare control (308) is moved proximally or distally relative to handle (300), a portion of snare (320) may be moved proximally or distally through elongate body (302). This, in turn, may cause a snare loop assembly to move between an open and a closed configuration, as described in more detail above.

[0112] While shown in FIG. 3B as having a locking collar (316), handle (300) need not. In variations that include a locking collar (316), locking collar (316) may be attached to elongate body (302) and held by handle (300) to help prevent elongate body (304) from being disengaged from handle (300). Similarly, while shown in FIGS. 3A and 3B as having a strain relief portion (304), handle (300) need not. In variations that include a strain relief portion (304), the strain relief portion (304) may stretch, compress, or otherwise deform to help reduce the strain placed on elongate body (304) by handle (300). This deformation may or may not be reversible. Generally, the strain relief portion (304) may be attached to both handle (300) and elongate body (304). When a force pushes, pulls, or twists elongate body (304) relative to handle (300), the strain relief portion (304) may resist this movement and thus a portion of the force may cause the strain relief portion to stretch, compress, or otherwise deform as mentioned above. The deformation of the strain relief portion (304) may act to reduce the relative movement between elongate body (304) and handle (300), which may help minimize the likelihood of the elongate body (304) disengaging from handle (300). Strain relief portion (304) may have any suitable size, shape, or configuration.

[0113] Additionally, while shown in FIG. 3B as having an interconnect (314), handle (300) need not. In variations that include an interconnect (314), interconnect (314) may be attached to elongate body (304), and may align the various lumens of elongate body (304) within handle (300). For example, in variations where handle (300) comprises a guidewire introducer (312), interconnect (314) may align guidewire introducer (312) with a working lumen (not shown) in elongate body (304). Interconnect (314) may align any number of device components with any number of lumens in elongate body (304).

[0114] While handle (300) is shown in FIGS. 3A and 3B to have a guidewire introducer (312), it may have any number of introducers or guides for introducing devices, fluids, or other components into elongate body (304). Indeed, handle (300) may have a guide to introduce one or more working devices such as a tissue grasper, a tissue ablator, cutting tool, visualization

device, a combination thereof, or the like, into a lumen in elongate body (304). In other variations, handle (300) may include an introducer to provide flushing, drug delivery, vacuum, or the like through a lumen in elongate body (304).

[0115] Furthermore, while shown in FIG. 3A as having a snare lock (306), handle (300) need not. In variations that include a snare lock (306), snare lock (306) may be used to prevent snare control (308) from being moved relative to handle (300). Thus, in order to manipulate a snare loop assembly (not shown) a user must first depress snare lock (306) to release snare control (308). Once snare control (308) is released, a user may push snare control distally or pull snare control proximally to open or close the snare loop assembly. When a user stops depressing snare lock (306), snare control (308), and with it the snare loop assembly, may again be locked in place. In other variations, handle (300) may have one or more features to prevent snare control (308) from being accidentally actuated. In some of these variations, snare control (308) may be configured such that it cannot slide relative to the handle unless a user first depresses the snare control itself. In other variations, the snare control (308) comprises a button or other control that must first be manipulated before the snare control (308) may be actuated. In still other variations, the snare control (308) may be freely actuated, but may be locked into place by depressing either a button, other control, or the snare control (308) itself.

[0116] Once the snare loop assembly is properly closed, suture fob (310) may be detached from the handle to tighten the suture loop (not shown). As suture fob (310) is pulled away from handle (300), suture fob (310) may pull suture through a suture knot (knot shown) to tighten the suture loop. As the suture loop is tightened, any excess suture held in the elongate body may be removed from the suture loop. Once this slack has been removed, the user may continue to pull suture fob (310) to disengage the suture loop from the snare loop assembly. Once disengaged from the snare loop assembly, the suture loop may be further tightened to ligate the enclosed tissue. The direct connection of suture fob (310) to suture (318) may provide tactile feedback to the operator to indicate the various stages of a closing procedure. More specifically, a user may experience different resistances when pulling suture fob (310) that may correspond to different stages of suture loop tightening. For example, a user may experience a given resistance when removing excess suture (318) from the suture loop. In variations where the closure device comprises a suture hook (not shown), the resistance may change when the suture (318) is released from the suture hook. Additionally, the resistance may change once all of the excess suture has been removed from the suture loop, once the suture loop starts being released from

the snare loop assembly, and once the suture loop is completely released from the snare loop assembly.

[0117] Additionally, in some variations it may be desirable to ensure that a user may only apply a given force to the suture loop. If a suture loop is tightened too much, it may damage the ensnared tissue. As such, in some variations a suture fob (310) may be configured to break away from suture (318) upon application of a predetermined force (for example, between about 8 lbs and about 10 lbs) to suture fob (310). In this way, the device may be configured such that a user may tighten a suture loop using a suture fob (310) without damaging the ensnared tissue, as the suture fob (310) may be configured to separate from the suture prior to damaging tissue.

[0118] Suture (318) may additionally include one or more visual markers (e.g., a colored coating) to indicate when the excess suture (318) has been removed from the suture loop. For example, a portion of suture (318) may have a colored marker located a certain distance from suture fob (310). The distance between the colored marker and the suture fob (310) may correspond to the amount of excess suture in the suture loop when the snare loop assembly is closed. A user may then pull suture (318) out of handle (300) using suture fob (310). When the colored marker becomes visible outside of handle (300) (or through a window in handle (300)), a user may know that the excess suture has been removed. Because the amount of excess suture may be dependent on the size of the loop formed by snare loop assembly, and because the size of the loop formed by snare loop assembly may be changed by snare control (308), in some instances the one or more visual markers on the suture (318) may correspond to one or more visual markers on snare control (308).

[0119] Additionally, suture (318) may be connected to suture fob (310) in any suitable manner. In some variations, such as that shown in FIG. 3B, one end of suture (318) may be connected directly to suture fob (310). In some of these variations, suture (318) may pass through a channel in suture fob (310), and may be knotted such that the resulting knot engages suture fob (310). In others of these variations, suture (318) may be clipped, grasped, or otherwise attached to suture fob (310). In other variations, suture fob (310) may comprise a pulley (not shown) that engages suture (318). In these variations, the end of suture (318) may be attached to another structure in handle (300), such as interconnect (314), and the pulley may slidably engage the suture (318). Because the suture is doubled-back over the pulley, a user may need to pull a suture fob (310) a shorter distance to achieve the same amount of tightening. For example, when a user withdraws a suture fob one inch, the pulley may also be withdrawn one

inch. During this withdrawal, the pulley may pull more suture (318) into handle (300). For each inch that pulley moves, about two inches of suture are pulled into handle (one inch for each portion of suture (318) on either side of the pulley), and thus a user need only move suture fob (310) half the distance to achieve the same level of tightening.

[0120] In some instances, it may be desirable to remove at least a portion of the excess suture without having to first disengage the suture fob. For example, FIG. 4 shows a perspective view of one variation of handle (400) attached to elongate body (402). Shown there is strain relief portion (404), suture fob (406), guidewire introducer (408), snare control (410), and suture fob control (412). Generally, snare control (410) may attach to a snare (not shown) to control a snare loop assembly (not shown), as described above. In some variations, snare control (410) may be configured to lock in place when not being actuated. In these instances, the snare control (410) may be unlocked in any number of ways, such as by depressing snare control (410) or by depressing a snare lock (not shown). In some of these variations, when snare control (410) or snare lock is no longer being depressed, snare control (410) is again locked into place.

[0121] In the variation shown in FIG. 4, suture fob (406) may be moved into and out of handle (400) by suture fob control (412). Suture fob (406) may be attached to a suture (not shown) in any manner as described above. Generally, the closure device is initially configured such that the suture fob control (412) is positioned near the distal end of handle (400), and suture fob (406) is entirely contained within handle (400). Suture fob control (412) may have one or more locking features like those described with respect to the snare control (410) above. Once the snare loop assembly has been closed around a target tissue using snare control (410), suture fob control (412) may be pulled proximally to the position shown in FIG. 4, to remove excess suture from the suture loop. Because movement of suture loop handle (412) is limited by the length of the track in which it sits, the length of this track may determine the amount of suture that may be removed from the suture loop. In other variations, the handle (400) may comprise one or more features (e.g., stops) that limit the amount that suture fob control (412) may move. Thus the amount of suture pulled by suture fob control (412) may be dependent on the track in which suture fob control (412) is disposed, as well as the manner in which the suture is attached to the suture fob (406). As such, handle (400) may be configured to remove a predetermined amount of excess suture from the suture loop (not shown) when suture fob control (412) is actuated. Once suture fob control (412) has been moved to the position shown in FIG. 4, suture fob (406) may project out of the end of handle (400) and may be disengaged from handle (400). Once disengaged, the suture fob (406) may be pulled to remove any remaining excess suture from the

suture loop, and then may be pulled to remove the suture loop from the snare loop assembly. Once the suture loop has been released from the snare loop assembly, the suture fob (406) may be used to further tighten the suture loop and ligate tissue.

[0122] In some variations, a suture fob control has one or more features to help facilitate actuation of the suture fob control. FIG. 5 shows one such variation of a handle (500). Shown there is handle (500) with snare control (502), suture fob (504), and suture fob controls (506) with extensions (508). Snare control (502) and suture fob controls (506) may work in any suitable manner as described above. Extensions (508) may be any suitable structure or protrusion attached to, formed in, or formed upon one or more suture fob controls (506) that provide a surface that can be grasped, gripped, or otherwise contacted by a user to facilitate actuation of the suture fob controls (506). Extensions may have any suitable size, shape, configuration, and orientation. For example, in the variation shown in FIG. 5, extensions (508) are configured to allow a user to hold and actuate the handle (500) in a “syringe-like” fashion.

[0123] In other variations, a handle may have one or more alternative mechanisms to help remove excess suture from a suture loop. FIG. 6 shows one such variation of handle (600) comprising snare control (602), suture fob (604), and squeeze grip (606). To remove excess suture from a suture loop, a user may repeatedly compress squeeze grip (606). When a user compresses squeeze grip (606), squeeze grip (606) may pull suture from suture loop into handle (600). In some of these variations, compressing squeeze grip (606) may rotate a suture reel (not shown), which may collect suture as it rotates. Once a sufficient amount of suture has been removed from the suture loop, suture fob (604) may be disengaged to release suture loop from the snare loop assembly, as described above.

[0124] FIG. 7 illustrates another variation of handle (700). Shown there is handle (700) comprising snare control (702), suture fob (704), and suture knob (706). In these variations, suture knob (706) may be rotated to remove excess suture from a suture loop. In some of these variations, suture knob (706) may rotate a suture reel, which collects suture as it rotates. In other variations, rotating suture knob (706) may move suture fob (704) into and out of handle (700), as described above in relation to FIG. 4. Suture knob (706) may have one or more visual indicators to indicate how much suture has been removed from suture loop. For example, specific distance markings may be placed on one or more surfaces of suture knob (706). Handle (700) may have one or more reference markers (not shown). The distance markings on suture knob (706) may be configured such that each distance marking on suture knob (706), when aligned with the

reference marker on handle (700), may correspond to the amount of suture that has been removed from the suture loop. For example, before the suture knob has been turned, a distance marking of “0” on suture knob (706) may be aligned with the reference marker, and may indicate that no suture has been removed from the suture loop. When the suture knob has been rotated a half-rotation, a distance marking of “3” on the suture knob (706) may be aligned with the reference marker on handle (700), and may indicate that 3 centimeters of suture has been removed from the suture loop. The specific distance markings on the suture knob (706) may depend on how much suture is removed from a suture loop as the suture knob (706) is rotated.

[0125] In other variations, a user may not be able to rotate suture knob (706) beyond a certain point. This feature may prevent a user from over-tightening the suture loop or unintentionally releasing the suture loop from the snare loop assembly. In some of these variations, the amount that suture knob (706) is able to rotate may correspond to the amount of excess suture in the suture loop. Generally, by only allowing a user to rotate a suture knob (706) a given distance, a user may know that they have removed a predetermined amount of suture from the suture loop. Depending on the configuration of handle (700), a user knows that all excess suture has removed from the suture loop, and the suture loop is ready to be released from the snare loop assembly. The suture fob (704) may then be released from the handle, and used to release suture loop from the snare loop assembly. Suture fob (704) may be released from handle (700) in any suitable way. In some variations, one or more buttons, knobs, or other controls may be actuated to release suture knob (704) from handle (700). By only allowing a user to rotate a suture knob (706) a given amount, the steps of tightening the suture loop and releasing the suture loop may be divided into two discrete steps, and thus a user does not to release the suture loop immediately after removing excess suture therefrom. This gives a user the ability to remove excess suture from the suture loop, and then to release the suture loop at his or her leisure. This in turn may provide an additional level of freedom to the user, who may want to attend to other matters between tightening the suture and releasing it from the snare loop assembly.

[0126] In some variations, a suture knob may be disengaged from the handle to act as a suture fob. FIG. 8 depicts one such variation of handle (800) comprising snare control (802) and suture knob (804). Suture knob (804) may have any suitable configuration, as described in U.S. Patent Application No. 12/055,213. Generally, suture knob (804) may be rotated to remove excess suture from a suture loop. In some variations, suture knob may only be rotated a certain amount, as described above. This may correspond to the amount of excess suture that is disposed in the suture loop. In some variations, one or more visual indicators, such as those described above,

may inform a user how much suture has been removed from the suture loop. In some variations, the suture knob (804) may be configured to only require a certain amount of force by a user in order to rotate suture knob (804). In other variations, the force required to rotate the suture knob (804) may be determined by the resistance provided by the suture loop, and thus may provide a user with tactile feedback while rotating the knob.

[0127] Once the suture knob (804) has been rotated to remove excess suture from the suture loop, the suture knob may be disengaged from handle (800) to act as a suture fob, as described above. In some variations, suture knob (804) may automatically disengage from handle (800) once suture knob (804) has been rotated a certain amount. In some of these variations, suture knob (804) may comprise threading (not shown) that may engage handle (800). When suture knob (804) is rotated a certain amount, it may become “unscrewed” and release suture knob (804) from handle (800). In other variations, suture knob (804) may automatically disengage from handle (800) when the suture loop is subjected to a predetermined force. In some of these variations, as the suture loop is tightened, it may pull one or more switches, levers, or other controls that disengages suture knob (804) from handle (800). In still other variations, the handle (800) may comprise one or more buttons, knobs, or levers that may be activated to release the suture knob (804) from the handle (800). Additionally, while shown in FIG. 8 to have a square suture knob (804), suture knob (804) may be of any suitable size or shape (e.g., square, rectangle, circle, oval, triangle, etc.).

[0128] Also provided here are ergonomically-improved handles. In some variations, the handle bodies may be shaped to contour to one or more portions of a user’s hand. In other variations, the handles described here may have widths greater than their heights. These variations may have any suitable height to width ratios, including, but not limited to about 1:1.5, about 1:2, about 1:2.5, about 1:3, or the like. When a user places one of these handles down on a surface, he or she may be more likely to place it on the wider base as opposed to one of the narrower sides. This may be beneficial in preventing device complications, such as rotation of the snare loop assembly, elongate body, or handle during a procedure, which may either damage the target tissue or interfere with the functioning of the closure device. If a user is less likely to place a handle on one of its narrower sides when setting the handle on a tray or another surface, then he or she may be less likely to overly rotate the handle during a procedure.

[0129] In other variations, the handle may comprise one or more protrusions that may help ensure the device is laid down with a particular orientation. FIG. 9 shows one such variation of

handle (900) comprising snare control (902), suture knob (904), suture knob release (906), and protrusions (908). Protrusions (908) may act to help ensure that handle (900) is only placed with a particular side down. While shown as having four separate protrusions (908), handle (900) may have any suitable number of protrusions (908), and each protrusion may have any suitable size and shape.

TENSIONING DEVICES

[0130] When the closure devices described above are used to place and tighten a suture loop around a tissue, it may be desirable to manage the tension applied to the suture as the suture loop is tightened. Accordingly, the closure devices described here may comprise one or more tensioning devices or mechanisms for manage the tension applied to a portion of the suture loop (e.g., a tail of the suture loop) of the closure device. In some instances, it may be desirable to limit the maximum tension that is applied to a suture loop at different times during tightening. For example, if a sufficiently large tension is applied to the suture loop, the suture loop may cut through, shear off, or otherwise damage the ensnared tissue, and/or may break or damage one or more components of the closure device. In some variations, the closure devices described may be configured to limit the tension that is applied to a suture loop during tightening of the suture loop. For example, in variations where the suture is attached to a suture fob (such as suture fob (310) shown in FIG. 3A), the suture fob may be configured to break away from a suture upon application of a predetermined force to the suture fob (for example, between about 8 lbs and about 10 lbs) to limit the tension applied to the suture.

[0131] In other instances, it may be desirable to facilitate the application of at least a minimum tension to a suture during tightening of a suture loop. For example, when the closure devices described here are used to close the left atrial appendage, it may be desirable to maximize closure of the left atrial appendage, which may reduce the possibility of blood or other materials passing into or out of the left atrial appendage through the ostium of the left atrial appendage. Accordingly tightening the suture loop by applying at least a minimum predetermined tension to the suture may help improve closure of the left atrial appendage, as will be described in more detail below. In some variations, the closure device may comprise one or more tensioning devices that may facilitate application of at least a predetermined minimum tension to a suture during tightening. Additionally, application of another predetermined tension to a suture may cause a suture loop to release from the snare loop assembly, as will be described in more detail below. By allowing a user to apply one or more predetermined tensions, the tensioning devices

may help to reduce user variability between different procedures, which may help to improve repeatability of tensioning across multiple procedures.

[0132] In yet other instances, the tensioning devices may be configured to facilitate the application of at least a minimum predetermined tension to a suture loop without exceeding a maximum predetermined tension. Additionally or alternatively, a tensioning device may be configured to facilitate the application of multiple predetermined tensions (or ranges of tensions). For example, in some variations (as will be described in more detail below), a tensioning device may have a first configuration in which the tensioning device facilitates the application of a first predetermined tension to a suture and a second configuration in which the tensioning device facilitates the application of a second predetermined tension to the suture. It may be desirable to enable a user to apply a first predetermined tension to the suture at a first point in time, and a second predetermined tension to the suture at a second point in time, as will be described in more detail below. Examples of illustrative tensioning devices will be described in more detail below.

[0133] In some variations, a tensioning device may comprise a force gauge, and may be used to provide a force measurement or other force indication to a user during tensioning of a suture loop. For example, FIGS. 31A and 31B show two variations of tensioning devices that each comprise a force gauge. FIG. 31A shows a side view of a first variation of tensioning device (3100), comprising a handle portion (3102), a suture attachment mechanism (3104), and a force indicator (3106). Generally, the suture attachment mechanism (3104) may grip, hold, or otherwise attach to a suture (3108) of a closure device (not shown), as will be described in more detail below. A user may then pull handle portion (3102) away from the closure device to apply a tensile force to the suture (3108). The suture attachment mechanism (3104) may be attached to a force gauge (not shown) housed within handle portion (3102), which may measure or otherwise provide an indication of the tension applied to suture (3108) via force indicator (3106).

[0134] As mentioned above, suture attachment mechanism (3104) may be any structure capable of gripping, holding, or otherwise attaching to suture (3108) (e.g., the tail of a suture loop). This connection may be temporary, or permanent. In some variations, the suture attachment mechanism (3104) may comprise one or more clips, clamps, or other mechanical holding structure for holding suture (3108). In other variations, the suture (3108) may be wound around one or tied to one or more portions of the suture attachment mechanism (3104). In

variations where the suture (3108) is attached to a suture fob (e.g., such as suture fob (3110) shown in FIG. 31A), the suture attachment mechanism (3104) may be configured to grip, hold, or otherwise attach to the suture fob (3110). For example, in the variation of tensioning device (3100) shown in FIG. 31A, suture attachment mechanism (3104) comprises a projection (3112) having an aperture (3114) extending at least partially therethrough. Aperture (3114) may be sized and shaped such that suture fob (3110) may be placed within aperture (3114) to temporarily engage and hold suture fob (3110) relative to suture attachment mechanism (3104). As a user pulls tensioning device (3100) away from closure device, the engagement between the suture fob (3110) and the suture attachment mechanism (3104) may pull the suture attachment mechanism (3104) away from handle portion (3102), which may apply a force to the force gauge.

[0135] Suture attachment mechanism (3104) may be attached to any suitable force gauge. For example, in some variations tensioning device (3100) may comprise a spring force gauge. In other variations, the force gauge may comprise one or more deflection beams, piezoelectric crystal, force-sensing resistors, combinations thereof, or the like. When a force is applied to the force gauge, as described immediately above, the force indicator (3106) may provide a measure or an indication of the tension being applied to suture (3108). The force indicator (3106) may be any mechanism suitable for providing an indication of the tension applied to suture (3108). For example, in the variation of tensioning device (3100) shown in FIG. 31A, the force indicator (3106) may comprise a moveable marker (3116) and a scale having indicator marks (3118). As tensioning device (3100) applies tension to suture (3108), marker (3116) may be configured to move along the scale to give a representation or measurement of the tension currently being applied to the suture (3108). Indicator marks (3118) may provide numerical values of the tension being applied and/or may provide levels to which a user should pull to achieve a desired level of tension. For example, in some variations, the force indicator (3106) may comprise a first mark and a second mark. In some variations, the first mark may be located such that in order to release the suture loop from the snare loop assembly, a user may pull on tensioning device (3100) until the movable marker (3116) reaches the first mark, thereby applying a first predetermined tension. Additionally or alternatively, the second mark may be located to facilitate application of a second predetermined force to the suture during tightening of the suture loop. Specifically, the user may pull on the tensioning device (3100) until the movable marker (3116) reaches the second mark, thereby applying the second predetermined tension. In other variations, such as shown in FIG. 31B, a tensioning device (3120) may comprise a force

indicator (3122) which comprises a digital display (3124). The remaining elements shown in FIG. 31B are the same as the variation of tensioning device (3100) shown in FIG. 31A, and are labeled as such. In still other variations, a force indicator may comprise one or more lights, which may be activated when the tension measured by tensioning device reaches a one predetermined levels, or when the tension supplied falls within a certain range.

[0136] FIGS. 32A-32C illustrate another variation of a tensioning device (3200). Specifically, FIGS. 32A-32C show a perspective view and two partial cross-sectional views, respectively, of tensioning device (3200), comprising a rotation knob (3202) with switch (3203), first clutch (3204), second clutch (3206), spooling member (3208), and base (3210). Base (3210) of tensioning device (3200) may be attached to or otherwise be formed as a part of a handle (not shown) of a closure device (not shown), such as one or more of the closure devices described in more detail above, and an end of suture (3212) may be attached to one more portions of spooling member (3208). Rotation knob (3202) may be rotated to rotate spooling member (3208) relative to base (3210), which may cause suture (3212) to wrap around spooling member (3208). As shown in FIGS. 32A-32C, spooling member (3208) may comprise a recessed portion (3214) in which the suture (3212) is wrapped. Tensioning device (3200) may be moved between a first configuration, in which tensioning device (3200) is configured to facilitate the application of a first predetermined tension to suture (3212), and a second configuration, in which the tensioning device (3200) is configured to facilitate the application a second predetermined tension to suture (3212). Additionally, tension device (3200) may limit the maximum tension applied to suture (3212), as will be described in more detail below.

[0137] As shown in FIGS. 32B and 32C, base (3210) may comprise a shaft (3216). Second clutch (3206) may be rotatably attached to shaft (3216), such that second clutch (3206) may freely rotate around shaft (3216). In some variations, the connection between the second clutch (3206) and shaft (3216) may also be configured such that the second clutch (3206) does not move axially relative to the shaft (3213), but need not be. Each of first (3204) and second (3206) clutches frictionally engages spooling member (3208) via clutch plates (3218), such that rotation of the first (3204) and/or second (3206) clutches may rotate the spooling member (3208), and vice versa.

[0138] In some variations, switch (3203) of rotation knob (3202) may be attached to an engagement rod (3220). Engagement rod (3220) may be configured to rotate relative to base (3210) as rotation knob (3202) is rotated. Switch (3203) may be moved between a first position,

as shown in FIG. 32B, and a second position, as shown in FIG. 32C, to move tensioning device (3200) between a first configuration and a second configuration. Moving switch (3203) from the first position to the second position may advance engagement rod (3220) into engagement with the second clutch (3206). Specifically, one or more grooves (3222) on the engagement rod (3220) may engage with one or more projections (3224) of the second clutch (3206) such that rotation of the engagement rod (3220) is translated to the second clutch (3206), as will be described in more detail below. Moving the switch (3203) back to the first position may disengage the engagement rod (3220) and the second clutch (3206), which may allow the engagement rod (3220) to rotate relative to the second clutch (3206).

[0139] As shown in FIGS. 32A-32C, rotation knob (3202) is directly attached to first clutch (3204), such that rotation of rotation knob (3202) relative to base (3210) also rotates the first clutch relative to base (3210). When tensioning device (3200) is in a first configuration (e.g., switch (3203) is in the position shown in FIG. 32B and engagement rod (3220) is disengaged from the second clutch (3206)), rotation of the rotation knob (3202) and first clutch (3210) relative to base (3210) may also rotate spooling member (3208) by virtue of the frictional engagement between the clutch plates (3218) of the first clutch (3210) and the spooling member (3208). As spooling member (3208) is rotated, suture (3212) may be wrapped around spooling member (3208). Additionally, the frictional engagement between spooling member (3208) and the second clutch (3206) may cause the second clutch (3206) to rotate around shaft (3216). As the suture (3212) is wrapped around the spooling member (3208), the tensioning device (3200) may increase the tension applied to suture (3212), which may act to resist rotation of the spooling member (3208). Eventually, this rotational resistance may overcome the frictional forces between the first clutch (3204) and the spooling member (3208), causing the clutch plates (3218) of the first clutch (3204) to slip relative to spooling member (3208). The first clutch (3204) may be configured such that clutch plates (3218) of first clutch (3204) begin slipping when a first predetermined tension (e.g., about 6 pounds) is applied to suture (3212). Additionally, because rotation of the rotation knob (3202) may no longer wrap suture (3212) around spooling member (3208) (due to the slipping between first clutch (3204) and spooling member (3208)), the tensioning device (3200) may be prevented from increasing the tension beyond the first predetermined tension while the tensioning device (3200) is in the first configuration.

[0140] When tensioning device (3200) is in its second configuration, as shown in FIG. 32C, engagement rod (3220) may engage second clutch (3206) such that rotation of rotation knob

(3202) rotates both first (3204) and second (3206) clutches relative to base (3210). As rotation knob (3202) is rotated, the frictional engagement between the spooling member (3208) and clutch plates (3218) of first (3204) and second (3206) clutches may cause the spooling member (3208) to rotate. This rotation may wind suture (3212) around spooling member (3208) until the tension in suture (3212) overcomes the frictional forces provided by both the first (3204) and second (3206) clutches, at which point the clutch plates (3218) may slip relative to spooling member (3208). The tensioning device (3200) may be configured such that slipping between the first (3204) and second (3206) clutches and spooling member (3208) occurs at a second predetermined suture tension (e.g., about 10 pounds) when the device is in the second configuration. Further rotation of rotation knob (3202) may not increase tension in the suture (3212) (due to slipping between the first (3204) and second (3206) clutches and the spooling member (3208)), which may prevent the tensioning device (3200) from increasing the tension beyond the second predetermined tension while the tensioning device (3200) is in the second configuration.

[0141] The tensioning device (3200) may be moved between first and second configurations to selectively manage the tension applied to suture (3212). For example, in some variations, a user may place the tensioning device (3200) in a first configuration, and may rotate the rotation knob (3202) until the tension in suture (3212) reaches a first predetermined tension (e.g., about 6 pounds), causing the rotation knob (3202) and first clutch (3204) to begin slipping relative to spooling member (3208), which may prevent additional tensioning. Once this tension has been achieved, the tensioning device (3200) may be moved to the second configuration, and the rotation knob (3202) may again rotated until suture (3212) reaches a second predetermined tension (e.g., about 10 pounds), again causing rotation knob (3202) (and first (3204) and second (3206) clutches) to begin slipping relative to spooling member, which may prevent additional tensioning.

[0142] FIGS. 33A-33G illustrate yet another variation of a tensioning device (3300) that may be used to tighten a suture loop. Specifically, FIGS. 33A and 33B show a perspective view and cross-sectional side view, respectively, of tensioning device (3300). As shown there, tensioning device (3300) may comprise a housing (3302) having handle portion (3304) and track (3306), first extension member (3308), second extension member (3310), first constant force spring (3312), second constant force spring (3314), and suture attachment mechanism (3316). Generally, each of the first (3308) and second (3310) extension members may be at least partially held within housing (3302), and may slide relative to housing (3302), as will be

described in more detail below. First extension member (3308), second extension member (3310) and/or housing (3302) may additionally comprise one or more stops (not shown) or other features that may prevent first extension member (3308) and/or second extension member (3310) from disengaging from the housing (3302) as they slide outward from housing (3302).

[0143] First (3312) and second (3314) constant force springs each may comprise a rolled ribbon of a material (e.g., stainless steel) which may exert a predetermined force when the ribbon as the ribbon is uncoiled and coiled. Specifically, first constant force spring (3312) may be configured to provide a first predetermined force (x1) (e.g., about 3 pounds, about 4 pounds, about 5 pounds, about 6 pounds, about 7 pounds, or the like) as the first constant force spring (3312) is coiled and/or uncoiled, and second constant force spring (3314) may provide a second predetermined force (x2) (e.g., about 3 pounds, about 4 pounds, about 5 pounds, about 6 pounds, about 7 pounds, or the like) as the second constant force spring (3314) is coiled and/or uncoiled. The force (x1) provided by the first constant force spring (3312) may be the same as, or may be different from, the force (x2) provided by the second constant force spring (3314). For example, in some variations, the first constant force spring (3312) may be configured to provide a force (x1) of about 6 pounds, while the second constant force spring (3314) may be configured to provide a force (x2) of about 4 pounds. A first end of the first constant force spring (3312) may be attached to the first extension member (3308), while a second end of the first constant force spring (3312) may be attached to the housing (3302) (e.g., via a first anchor post (3318), or the like). Similarly, a first end of the second constant force spring (3314) may be attached to the second extension member (3310), while a second end of the second constant force spring (3314) may be attached to the housing (3302) (e.g., via a second anchor post (3320), or the like). As shown in FIGS. 33A-33G, suture attachment mechanism (3316) may be attached to, or otherwise extend from, first extension member (3308), but it should be appreciated that in some variations the suture attachment mechanism may be attached to the second extension member. In still other variations, each of suture first and second extension members may comprise a suture attachment mechanism.

[0144] Tensioning device (3300) may facilitate tightening of a suture loop (not shown). In use, tensioning device (3300) may grip, hold, or otherwise attach to a suture (3322) via suture attachment mechanism (3316). Suture attachment mechanism (3316) may be any structure capable of gripping, holding, or otherwise attaching to a suture (or to a suture fob, in variations where a portion of the suture is attached to a suture fob), such as one or more of the suture attachment mechanisms described in more detail above. For example, in the variation of

tensioning device (3300) shown in FIGS. 33A-33G, suture attachment mechanism (3316) comprises a projection (3324) with an aperture (3326) for receiving and holding suture fob (3328).

[0145] Once suture attachment mechanism (3316) has engaged suture (3322) (e.g., via a suture fob), the tensioning device (3300) may be configured to apply either a first predetermined tension or a second predetermined tension to suture (3322). To apply the first predetermined tension, the tensioning device (3300) may be placed in a first configuration, as shown in FIG. 33A, and a user may grip housing (3302) (e.g., via handle portion (3304)) and pull tensioning device (3300) away from the closure device (not shown) to apply tension to suture (3322). This tension may also act to pull first extension member (3308) away from housing (3302). First constant force spring (3312), by virtue of its attachment to first extension member (3308), may resist this movement of first extension member (3308) until the tension is approximately equal to the predetermined force (x1) provided by the first constant force spring (3312). When the tension in suture (3322) reaches this force (x1), first constant force spring (3312) may begin to uncoil, and first extension member (3308) may slide at least partially out from housing (3302), as shown in a perspective view and a cross-sectional side view in FIGS. 33C and 33D, respectively. Accordingly, to allow tensioning device (3300) to apply the first predetermined tension (which may be approximately the same as force (x1) provided by first constant force spring (3312)), a user may pull tensioning device (3300) until the first extension member (3308) begins to slide out of housing (3302). For example, in variations where first constant force spring (3312) is configured to supply a force of about 6 lbs, the tension applied by tensioning device (3300) during movement of the first extension member (3308) may be about 6 lbs. Additionally, because first constant force spring (3312) continues to apply the predetermined force (x1) as first extension member (3308) moves relative to housing (3302), the tensioning device (3300) may maintain the first predetermined tension in suture (3322) and in some instances may prevent the user from exceeding the predetermined tension.

[0146] To configure the tensioning device (3300) to apply a second pre-set tension to suture (3322), first extension member (3308) and second extension member (3310) may temporarily be connected to place the tensioning device (3300) in a second configuration. For example, as shown in FIG. 33E, a pin (3338) or other locking structure may be inserted through track (3306) of housing (3302) and may be placed at least partially through an aperture (3330) of second extension member (3310) and aperture (3332) of first extension member (3308) such that pin (3338) couples first (3308) and second (3310) extension members to hold the extension

members relative to each other. To apply the second predetermined tension, a user may grip housing (3302) (e.g., via handle portion (3304)) and pull tensioning device (3300) away from the closure device (not shown) to apply tension to suture (3322). This tension may also act to pull first (3308) and second (3310) extension members away from housing (3302) (because pin (3338) couples the first (3308) and second (3310) extension members, the extension members may move together as a single unit). In this instance, both first constant force spring (3312) (by virtue of its attachment to first extension member (3308)) and second constant force spring (by virtue of its attachment to second extension member (3310)), may resist this movement of first (3308) and second (3310) extension members until the tension in suture (3322) reaches the sum of the forces (x1) and (x2) provided by first (3312) and second (3314) constant force springs. When the tension in suture (3322) reaches this force ((x1)+(x2)), first (3312) and second (3314) constant force springs may begin to uncoil, and first (3308) and second (3310) extension members may slide at least partially out from housing (3302), as shown in a perspective view and a cross-sectional side view in FIGS. 33F and 33G, respectively. As first (3308) and second (3310) extension members slide from housing (3302), pin (3338) may slide within track (3306). Accordingly, to allow tensioning device (3300) to apply the first predetermined tension (which may be approximately equal to the sum of forces (x1) and (x2) provided by first (3312) and second (3314) constant force springs), a user may pull tensioning device (3300) until the first (3308) and second (3310) extension members start being pulled out of housing (3302). For example, in variations where first constant force spring (3312) is configured to supply a force of about 6 lbs and the second constant force spring (3314) is configured to supply a force of about 4 lbs, the tension applied by tensioning device (3300) during movement of the first (3308) and second (3310) extension member may be about 10 lbs. Additionally, because first (3312) and second (3314) constant force springs continue to apply the first and second predetermined forces ((x1) and (x2)) as first (3308) and second (3310) extension members move relative to housing (3302), the tensioning device (3300) may maintain the first predetermined tension in suture (3322) and in some instances may prevent the user from exceeding the predetermined tension.

[0147] While each of the extension members are shown in FIGS. 33A-33G as being connected to a single constant force spring, it should be appreciated that each of the extension members may be connected to any suitable number of constant force springs (e.g., one, two, or three or more constant force springs). Additionally, while shown in FIGS. 33A-33G as having two extension members, it should be appreciated that tensioning device (3300) may comprise any suitable number of extension members (e.g., one, two, or three or more). For example, in

some variations, a tensioning device may comprise a single extension member. In some of these variations, the extension member may be configured to extend from the housing when a predetermined tension is applied to a suture. In others of these variations, the extension member may be selectively connected to multiple constant force springs such that the tensioning device may supply one of a plurality of predetermined tensions to a suture. For example, the extension member may be configured to switch from attachment to a first constant force spring (or a first plurality of constant force springs), which may allow the tensioning device to apply a first predetermined tension (e.g., about 6 pounds) to the suture, to attachment to a second constant force spring (or second plurality of second constant force springs) to allow the tensioning device to apply a second predetermined tension (e.g., about 10 pounds) to the suture.

[0148] FIGS. 35A-35D depict a variation of a closure device (3500) comprising a tensioning mechanism (3502). As shown in a perspective view FIG. 35A, the closure device (3500) may comprise a handle (3504), an elongate body (3506), and a snare loop assembly (3508). The closure device handle (3504), elongate body (3506), and snare loop assembly (3508) may include any combination of handles, elongate bodies, and snare loop assemblies or features thereof, as described above. In some variations, the snare loop assembly (3508) may comprise a snare and a suture loop releasably connected via a retention member, and the snare may be used to open and close the snare loop assembly (3508) via a snare control (3510), as described in more detail above. The snare control (3510) may be any knob, slider, lever, button, or the like.

[0149] The handle (3504) of the closure device (3500) may comprise a tensioning mechanism (3502). As shown in FIG. 35A and in an exploded view in FIG. 35B (with a bottom portion of the handle (3504) removed), the tensioning mechanism (3502) may comprise a rotation knob (3512), an axle (3514) attached to an indicator body (3516), and a spring member (3518) connecting the rotation knob (3512) and the axle (3514). Axle (3514) may be rotatably connected to the handle (3504) such that rotation of the axle (3514) in a first direction (as indicated by arrow (3546)) applies tension to a suture (3520). For example, the tensioning mechanism (3502) may comprise a spool (3522) which may be rotated as the axle (3514) is rotated. The axle (3514) may rotate the spool (3522) in any suitable manner. In some variations the axle (3514) may be fixedly attached to the spool (3522) such that the axle (3514) and spool (3522) rotate together. In other variations (such as the variation shown in FIGS. 35A-35D), the axle (3514) may be connected to a first miter gear (3524) and the spool (3522) may be connected to a second miter gear (3526) which engages the first miter gear (3524). Rotation of the axle (3514) may rotate the first miter gear (3524), which may rotate the second miter gear (3526) and

the spool (3522). Rotation of the spool (3522) in a first direction may collect suture (3520) onto the spool, which may tension the suture (3520) and tighten a suture loop (not shown) of the snare loop assembly (3508). Rotation of the spool (3522) in a second direction may release suture (3520) from the spool (3522), and may reduce tension on the suture (3520). The rotation knob (3512) may be used to rotate the axle (3514) and apply tension to the suture (3520), as will be described in more detail below. The connection between the axle (3514) and the indicator body (3516) may be such that the axle (3514) and indicator body (3516) may rotate together. In some variations, the axle (3514) and indicator body (3516) may be formed as multiple components and joined together, or may be formed as a single component.

[0150] In some variations, the axle (3514) may be configured to rotate in only one direction relative to the handle (3504). For example, in some variations, the axle (3514) may comprise a ratchet mechanism (3528) and the handle (3504) may comprise a pawl (3530), such that pawl (3530) allows rotation of the ratchet mechanism (3528) (and thus the axle (3514)) in a first direction, but prevents rotation of the ratchet mechanism (3528) in the opposite direction. In some of these variations, the pawl (3530) may be moveable or otherwise disengaged from the ratchet mechanism (3528) to allow rotation of the ratchet mechanism (3528) in either direction. For example, in the variation shown in FIGS. 35A-35D, the handle (3504) may comprise a button (3532) which may temporarily disengage the pawl (3530) from the ratchet mechanism (3528), thereby allowing rotation of the axle (3514) in a second direction. The pawl (3530) may be disengaged by any suitable mechanism (e.g., a button, a slider, a lever, or the like), and may be disengaged when it is desirable to release tension that has been applied to the suture (3520).

[0151] When the snare loop assembly (3508) comprises a suture loop releasably attached to one or more components of the snare loop assembly (3508) (e.g., a snare), the tensioning mechanism (3502) may be configured to release the suture loop and to tighten the suture around tissue captured by the snare loop assembly (3508). Specifically, when the snare loop assembly (3508) captures and is closed around a target tissue, the rotation knob (3512) may be rotated to tighten the suture loop (e.g., to reduce the diameter of the suture loop). Rotation of the rotation knob (3512) may be at least partially translated to the axle (3514) and the indicator body (3516) via the spring member (3518). For example, the spring member (3518) may comprise a torsional spring (3534) with a first leg (3536) attached to the rotation knob (3512) and a second leg (3538) attached to the axle (3514) and/or the indicator body (3516). Rotation of the rotation knob (3512) may apply a force to the first leg (3536), and this force may be translated to the second leg (3538) which may result in rotation of the axle (3514) and indicator body (3516). In

variations where the suture loop comprises excess suture (e.g., within the elongate body (3506)), rotation of the rotation knob (3512) may cause this excess suture to be removed from the suture loop (e.g., through a suture knot). In some of these variations, the spring force of the spring member (3518) may be stiff enough such that the spring member (3518) does not twist during this initial tightening (i.e., before the suture loop is released from the snare loop assembly), and thus the rotation knob (3512) does not rotate relative to the axle (3514) and indicator body (3516). The rotation knob (3512) can be used to rotate the axle (3514) and indicator (3516), as shown in FIG. 35C, which may in turn rotate the spool (3522) to tighten the suture loop until the suture loop is released from the snare loop assembly (e.g., the suture loop is pulled through a portion of a retention member).

[0152] After the suture loop has been released from the snare loop assembly, continued rotation of the rotation knob (3512) may further tighten the suture around the captured tissue. As the suture loop is tightened around tissue, rotation of the rotation knob (3512) increases the tension on the suture (3520). This increased tension may resist further rotation of the axle (3514) and indicator body (3516). Eventually, the increased tension may overcome the spring force of the spring member, the spring member (3518) will begin to twist such that the first leg (3536) may rotate toward the second leg (3538) and the rotation knob (3512) rotates relative to the indicator body (3516). The indicator body (3516) may comprise a first set of markings (3540) and the rotation handle (3512) may comprise a second set of markings (3542), such that the relative positioning between markings (3540) on the indicator body (3516) and the markings (3542) on the rotation handle (3512) is indicative of the force being applied to the suture (3520). For example, in some variations, one or more of the markings may provide numerical values of the tension being applied to the suture and/or may provide levels to which a user should pull to achieve a desired level of tension. In some variations, the rotation knob (3512) may be rotated until the relative positioning between the markings (3540) and (3542) indicates that a desired final tightening force has been applied to the suture (3520). When the force applied to the suture (3520) is at or below a first predetermined level (e.g., less than or equal to about 6 lbs, less than or equal to about 5 lbs, or the like), the markings on the rotation handle and the indicator body may be aligned in a first configuration (for example, in the variation of the closure device (3500) described above in relation to FIGS. 35A-35D, the markings (3542) of the rotation handle (3512) may be aligned with the thinnest portion of the ramped markings of the indicator body (3516) as depicted in FIG. 35C). When the force applied to the suture (3520) reaches a second predetermined level (e.g., about 9 lbs, about 10 lbs, or the like), the markings may be aligned in

a second configuration (for example, in the variation of the closure device (3500) described above in relation to FIGS. 35A-35D, the markings (3542) of the rotation handle (3512) may be aligned with the thickest portion of the ramped markings of the indicator body (3516) as depicted in FIG. 35D). It should be appreciated that the markings of the indicator body and the rotation handle may be aligned in any number of different configurations to represent respective force levels applied to the suture (3520) by the tensioning mechanism (3502).

[0153] In some variations, the handle (3504) may further comprise a stop (3544) which may resist or otherwise prevent unintentional rotation of the indicator body (3516) and axle (3514). The stop (3544) may include a first position in which the stop (3544) engages the indicator body (3516) and/or axle (3514) to prevent these elements from rotating relative to handle (3504). When a user wishes to tighten the suture loop, the stop (3544) may be moved to a second position in which the stop (3544) does not engage the indicator body (3516)/axle (3514), thereby allowing rotation of the tensioning mechanism (3502). Additionally, while the closure mechanism (3502) described above with respect to FIGS. 35A-35D is shown as being integrated with the handle (3504), it should be appreciated that the closure mechanism may be a separate device from the closure device (3500) and may engage and tighten a suture loop of the closure device (3500).

METHODS

[0154] Methods for closing the left atrial appendage are also described here. It should be appreciated that any of the devices described above may be used in conjunction with one or more of the methods described here or those described in U.S. Patent Application No. 12/055,213. Generally, methods described here comprise accessing the left atrial appendage. Once access has been achieved, a closure device (such as those described above) may be advanced to the left atrial appendage. In some variations, the closure devices may be advanced and positioned with the help of one or more guide devices and/or one or more stabilizing/positioning devices (e.g., an expandable member or the like). The closure device may be used to ensnare and close the left atrial appendage. A suture loop or other closure element may be tightened and released from the closure device to hold the left atrial appendage in closed configuration. Once or more tensioning devices may be utilized to tighten and/or release the suture loop. The closure device may be withdrawn, and a portion of the suture may be severed. These steps will be described in more detail below.

[0155] As mentioned above, some variations of the methods described here may comprise gaining access to the left atrial appendage. In some variations, the methods for closing the left atrial appendage include accessing the left atrial appendage from both the inside of the heart and the outside of the heart. To access the inside of the heart, the vasculature is typically used. For example, access may be obtained via one or several of the various veins or arteries (jugular, femoral, carotid, etc.). In some variations, the heart is accessed on the inside via the common femoral vein (e.g., the left common femoral vein) using a standard Seldinger technique with a needle. An introducer wire may then be advanced through the needle, followed by an introducer sheath. The introducer wire may then be removed. In some variations, a guiding catheter sheath may be placed as an alternative to an introducer sheath or the initial sheath may be replaced with a guiding catheter sheath.

[0156] Using fluoroscopy, an angiogram performed through the sheath, a catheter placed through the sheath, a guiding catheter sheath, or any combination thereof, may be performed to observe anatomical characteristics and considerations of the access route for the purpose of transseptal access into the left atrium (e.g., tortuosity, clots, devices, such as vena cava filters, etc.). Fluoroscopy, ultrasound, intracardiac echocardiography, extracardiac echocardiography, transesophageal echocardiography, or combinations thereof, may be used to help visualize transseptal access to the left atrium, and access to the left atrium may be obtained using standard transseptal access techniques.

[0157] For access to the heart from the outside, a subthoracic access point may be used. The access point is typically identified based on patient anatomical characteristics. In some variations, the access point may be any suitable location (e.g., intercostal access via a sternotomy, thoracostomy, or thoracotomy, right of the xiphoid process and pointed towards the patient's left shoulder, or in the costal cartilage or xiphoid process itself). Once the access point has been determined, a needle (e.g., a 17G Tuohy needle) may be advanced using standard pericardiocentesis techniques under fluoroscopic guidance. After access to the pericardium has been obtained, a guidewire may be advanced through the needle under fluoroscopic visualization within the pericardial sac. The needle may then be removed. Access to the pericardial space has thus been obtained.

[0158] In other variations, the left atrial appendage may be closed off using the systems and devices described here without performing both access procedures as described above. For example, in some variations the methods comprise advancing a first guide having a proximal end

and a distal end into the left atrial appendage, through the left atrial appendage, and out of the left atrial appendage, such that one of the proximal or distal ends is within the vasculature, and one of the proximal or distal ends is within the subthoracic space.

[0159] By virtue of gaining access to the left atrial appendage, one or more guides having alignment members may be advanced to the left atrial appendage. These guides may be any suitable guide, such as those described in U.S. Patent Application No. 12/055,213. For example, first and second guides having alignment members may be used to guide the procedure. The alignment member may be any suitable alignment member (e.g., interconnecting elements, one or more vacuum members, radiopaque or echogenic markers, members that are configured to produce an audible response, magnets, etc.). In some variations, the alignment members are magnets located at the distal ends of the guides. The magnets may be made from or comprise any suitable magnetic material, e.g., a rare earth magnet, such as neodymium-iron-boron, cobalt-samarium, or other powerful fixed magnet elements. These guides may be used for guiding additional tools and/or devices to the left atrial appendage.

[0160] For example, in some variations, a first guide may be advanced into the left atrial appendage, while the second guide may be advanced into the pericardial space adjacent to the left atrial appendage. Either of these guides may be advanced under any of a variety of visualization techniques, e.g., fluoroscopic visualization, ultrasound visualization, some combination thereof, etc. Once the first and second guide members have been advanced to the left atrial appendage, one or more positioning and/or stabilizing elements (e.g., balloons or other expandable structures) may be advanced over or in conjunction with the first guide (e.g., it may be coupled to or be part of the first guide) and into the left atrial appendage. Similarly, a closure device may be advanced over the second guide to the exterior of the left atrial appendage. It should be appreciated that the closure device may be any of the closure devices described above.

[0161] When placed in the left atrial appendage, the positioning element may be used to help position the snare loop assembly of a closure device. In some variations, an expandable structure may be inflated or otherwise expanded in or near the opening of the left atrial appendage and the snare loop assembly of the closure device may be closed around the left atrial appendage distally of the expandable structure. In these variations, the expandable structure may help position the closure device away from the Coumadin ridge. In other variations, the expandable member may be expanded inside of the left atrial appendage. In some of these variations, when the expandable member is expanded, the left atrial appendage may become

distended and its shape changed from roughly conical to roughly spherical, thus better defining the junction between the left atrial appendage and left atrium. In addition, the expandable member in its expanded state may be at a pressure much greater than that of the left atrium proper, resulting in a significant differential in tension between the left atrial appendage and the left atrium. In these variations, the expandable member may help position the closure device near the base of the left atrial appendage. In still other variations, one expandable structure may be expanded in or near the opening of the left atrial appendage while a second expandable structure may be expanded inside of the left atrial appendage. In these variations, the snare loop assembly of the closure device may be closed around the left atrial appendage between the two expandable structures, which may help ensure correct device positioning.

[0162] It should be appreciated that the expandable structure may be any suitable expandable structure. In some variations, one or more the expandable structures may be a balloon or another inflatable structure. In some of these variations, the balloon or balloons may be attached to a catheter. In some variations, the balloon or inflatable structure may be configured to be detached in an expanded state inside of the left atrial appendage. In other variations, the expandable structure may comprise an expandable mesh or cage structure. This mesh may be self-expanding or mechanically expandable, and may be made from any suitable material (e.g., platinum, nitinol, stainless steel, Dacron wool, PTFE, combinations thereof, or the like). Again, the expandable mesh or cage structure may be configured to be detached in an expanded state in the left atrial appendage, but need not be.

[0163] While the expandable member is in an expanded state, the snare loop assembly may be moved to an open configuration and may be placed around a portion of the left atrial appendage. Once placed around the left atrial appendage, the snare loop assembly may be closed around the left atrial appendage. In some variations, the snare loop assembly is placed around the left atrial appendage while the balloon is in its deflated or unexpanded state, and then the balloon is expanded after the snare loop assembly is closed. In some instances it may be desirable to confirm proper closure of the appendage prior to tightening of the suture. If closure is not adequate or otherwise not desirable, the snare loop assembly may be opened, repositioned, closed, and then confirmed once again.

[0164] Once proper closure has been affected, the suture loop may be tightened to release the suture loop from the snare loop assembly. In some variations, the snare loop assembly may then be returned to an open configuration and the suture loop may be tightened again. This may act

to help ensure that the suture loop is sufficiently tightened around the left atrial appendage. In some variations, a user may re-tighten the suture loop after waiting for a period of time. This waiting period may allow tissue to readjust and settle within suture loop, which may allow for a tighter closure of tissue. This period of time may be any suitable period of time, such as, for example, greater than about 30 seconds, greater than about a minute, or greater than about 2 minutes. After releasing the suture loop from the snare loop assembly, the closure device may be withdrawn. In some variations, it may be desirable to further tighten the suture loop after the closure device has been withdrawn. This may be accomplished with one or more additional devices (e.g., a knot pusher).

[0165] It should be appreciated that one or more of the tensioning devices described above may be utilized to manage the tension applied to the suture loop during tightening of the suture loop, which may increase repeatability of suture loop tightening by reducing user variation. For example, FIG. 34 depicts a flowchart of one method by which one or more tensioning device may be used to assist in the tightening of a suture loop to close off the left atrial appendage. While described here as being used to close the left atrial appendage, it should be appreciated that the methods described here may be used to close any suitable target tissue. As mentioned above, a snare loop assembly may be advanced and positioned around the left atrial appendage (3400), such as in one of the manners described in more detail above. Once placed around the left atrial appendage, the snare loop assembly may be closed around the left atrial appendage to close the left atrial appendage (3402). Once proper positioning of the closed snare loop assembly has been achieved (and optionally confirmed via visualization), a tensioning device may be used to release the suture loop from the snare loop assembly. Specifically, a tensioning device may be used to apply a first predetermined tension to the suture loop (3406). The tensioning device and closure device may be configured such that suture loop may be released from the snare loop assembly at or before the time the tension applied to the suture reaches the first predetermined tension. The first predetermined tension may be any suitable value. In some instances, variations resulting from manufacturing and/or delivery conditions may affect the tension required to release the suture loop from the snare loop assembly. In these instances, it may be desirable to set the first predetermined tension to a value greater than or equal to the largest release tension expected of the closure device. For example, the suture loop may be configured to release from the snare loop assembly at tensions less than or equal to about 6 pounds (e.g., between about 5 pounds and about 6 pounds, etc.). In some of these variations, the tensioning device may be configured to apply a first predetermined tension of about 6 pounds or

a first predetermined tension greater than about 6 pounds, which may allow the suture loop to be released when the first predetermined tension has been applied to the suture.

[0166] Once the suture loop has been released from the snare loop assembly, the remaining components of the snare loop assembly (e.g., a snare and/or retention member) may optionally be re-opened (3408), as mentioned immediately above, and the suture loop may be tightened around the left atrial appendage. In some variations, a tensioning device may provide a second predetermined tension to the suture loop (3410) to tighten the suture loop. Applying a second predetermined tension to the suture loop may help to improve the closure of the left atrial appendage, which may reduce the likelihood that blood or other materials (e.g., thrombi) are able to pass through the ostium of the left atrial appendage. Specifically, in some instances it may be desirable to tighten the suture loop to achieve a certain diameter (or range of diameters) of the suture loop as it closes around the left atrial appendage. Additionally or alternatively, it may be desirable to tighten the suture loop such that the suture loop provides a certain tightening force to the ensnared tissue (e.g., at least about 4 lbs, at least about 5 lbs, between about 3 pounds and about 6 pounds, etc.). The second predetermined tension may be configured such that application of the second predetermined tension (e.g., about 10 pounds, at least about 10 pounds, between about 9 pounds, between about 11 pounds, or the like) to the suture may achieve a desired diameter of the suture loop and/or provides a desired tightening force to the ensnared tissue. This, in turn, may increase the likelihood that the left atrial appendage is sufficiently closed. Additionally, repeated application of the predetermined tension across multiple procedures may allow for predictable and repeatable closure of the left atrial appendage. The tensioning device may also be configured to limit the user's ability to exceed the second predetermined tension, or to exceed an undesirable tension level.

[0167] The closure device may optionally be left in place for a specific amount of time (e.g., greater than about 30 seconds, greater than about a minute, greater than about 2 minutes, greater than about 4 minutes, or the like), to allow the ensnared tissue to reposition or otherwise settle within the suture loop, if at all (3412). The suture loop may then be re-tightened (3414). In some variations, a tensioning device may apply a third predetermined tension to the suture loop. It should be appreciated that in some variations, the third predetermined tension may be approximately equal to the second predetermined tension. In other variations, the third predetermined tension may be greater than the second predetermined tension. In still other variations, the third predetermined tension may be less than the second predetermined tension.

Optionally, the steps of leaving the closure device in place for a period of time and then re-tightening the suture loop may be repeated one or more times as necessary.

[0168] While tensioning devices are described above as applying a first predetermined tension (to release suture loop from snare loop assembly), a second predetermined tension (to tighten the suture loop) and a third predetermined tension (to re-tighten the suture loop), it should be appreciated that tensioning devices may only be used during some of the above-mentioned steps. Additionally, in some variations, the same tensioning device is used to provide multiple different predetermined tensions to the suture loop (e.g., a tension device may be used to provide a first predetermined tension at a first point in time, and then may be used to provide a second predetermined tension at a second point in time). In other variations, different tensioning devices may be used to provide different predetermined tensions (e.g., a first tensioning device may be used to provide a first predetermined tension (e.g., about 6 pounds), while a second tensioning device may be used to provide a second predetermined tension (e.g., about 10 pounds).

[0169] It should be appreciated that any of the tensioning devices described above may be used to apply the first and/or second (and/or third, if applicable) predetermined tensions to the suture loop during tightening of the suture loop. For example, in some variations a tensioning device comprising a force gauge (e.g., tensioning device (3100) described above with respect to FIG. 31A) may be used to ensure that one or more predetermined tensions are applied to the suture loop. In these variations, a user may attach the tensioning device to the suture using a suture attachment mechanism (as described in more detail below), and may apply tension to the suture using the tensioning device. For example, to release the suture loop from the snare loop assembly, the user may apply increasing tension until the force indicator of the tensioning device indicates that the first predetermined tension has been applied. Additionally or alternatively, when tightening (or re-tightening) the suture loop, the user may apply increasing tension until the force indicator indicates that the second (or third) predetermined tension has been applied.

[0170] In other instances, the variation of the tensioning device (3200) described above in relation to FIGS. 32A-32C may also be used to apply one or more predetermined tension values to the suture loop. For example, tensioning device (3200) may be configured to apply the first predetermined tension when placed in the first configuration (as shown in FIG. 32A), and to apply the second predetermined tension when placed in the second configuration (as shown in FIG. 32B). To release suture loop from the snare loop assembly, the tensioning device (3200)

may be attached to the suture and placed in the first configuration, and rotating knob (3202) may be rotated until the first predetermined tension is reached and the first clutch plate (3204) begins slipping relative to spooling member (3208). Similarly, to tighten (or re-tighten) the suture loop, the tensioning device (3200) may be placed in the second configuration, and rotating knob (3202) may again be rotated until the second predetermined tension is reached and the clutch plates (3218) of the first (3204) and second (3206) clutches begin slipping relative to spooling member (3208). Additionally, in these variations the tensioning device (3200) may limit the tension applied by the tensioning device (e.g., due to the slipping of clutch plates), which may help prevent premature tightening and/or over-tightening of the suture loop.

[0171] In other variations, the variation of tensioning device (3300) described above in relation to FIGS. 33A-33G may also be used to apply one or more predetermined tension values to the suture loop. In some of these variations, tensioning device (3300) may be configured to apply the first predetermined tension when in the first configuration (as described above in relation to FIGS. 33A-33D) and may be configured to apply the second predetermined tension when in the second configuration (as described above in relation to FIGS. 33E-33G).

Accordingly, to release the suture loop from the snare loop assembly, the tensioning device (3300) may be attached to the suture and placed in the first configuration, and tensioning device (3300) may be pulled away from the closure device (not shown) until the tension applied to the suture reaches the first predetermined tension, and the first extension member (3308) begins to slide away from housing (3302). Similarly, to tighten (or re-tighten) the suture loop, the tensioning device (3300) may be placed in the second configuration (as described in more detail above), and tensioning device (3300) may be pulled away from the closure device (not shown) until the tension applied to the suture reaches the second predetermined tension, and the first (3308) and second (3310) extension members begin to pull away from the closure device. Additionally, in these variations the tensioning device (3300) may limit the tension applied by the tensioning device (e.g., due to the set force applied by the constant force springs during movement), which may help prevent premature tightening and/or over-tightening of the suture loop.

[0172] In still other instances, a tensioning mechanism (3502) described above in relation to FIGS. 35A-35D may also be used to apply one or more predetermined tension values to the suture loop. To release the suture loop from the snare loop assembly, the rotation knob (3512) may be rotated until rotation knob (3512) begins to rotate relative to the indicator body (3516). To tighten (or re-tighten) the suture loop, the rotation knob (3512) may be further rotated until

the relative positioning between the rotation knob (3512) and the indicator body (3516) indicates that a second (or third) predetermined tension has been reached.

[0173] It should be appreciated that some or all of the guide member or positioning elements may be removed from the left atrial appendage at any suitable point or points during the methods. For example, in some variations, some or all of these devices or device components may be removed from the left atrial appendage after closing the snare loop assembly but prior to releasing the suture loop from the snare loop assembly. In other variations, some or all of these structures may be removed after releasing the suture loop from the snare loop assembly. The suture loop may be further tightened after some or all of these elements are removed. In still other variations, one or more expandable members may be detached and may remain in the left atrial appendage. In these variations, the expanded member may act to displace blood from the left atrial appendage and to help keep additional blood from entering the left atrial appendage. When the expandable member comprises a balloon or inflatable structure, the balloon may be filled with any suitable substance, such as, for example, saline or one or more hydrophilic polymers (e.g., hydroxyethyl methacrylate).

[0174] In yet other variations, one of the guide members or other elements placed inside of the left atrial appendage may be configured to release one or more materials to the closed left atrial appendage prior to removal. This material may act to create haemostasis or embolization of the closed left atrial appendage, which may prevent the ingress and egress of blood from the closed left atrial appendage. Examples of suitable materials include, but are not limited to gelatins (e.g., gel foam), liquid embolic agents (e.g. n-butyle-2-cyanoacrylate, ethidol), gelatin microspheres (e.g., polyvinyl alcohol acrylic microspheres), or pieces of thrombotic materials (e.g., platinum, stainless steel, Dacron wool, combinations thereof or the like).

[0175] In some variations, it may be desirable to lock the suture knot in place once the suture loop has been tightened around the left atrial appendage. In some variations, the suture knot may be locked using one or more unidirectional locking structures, as described in more detail above. In other variations, the knot may be locked in place with one or more bioglues or other biocompatible adhesives (e.g., cyanoacrylate). In still other variations, energy (e.g., RF energy, thermal energy, light energy, or the like) may be used to fuse the knot in place. In yet other variations, one or more portions of the suture knot may be configured to expand upon application of or exposure to one or more stimuli. For example, in some variations the suture

may comprise collagen filaments that may be exposed to moisture when the suture is severed. Once the collagen is exposed to moisture, it may expand to lock the suture knot in place.

[0176] Once the suture loop has been properly placed, the suture may be severed in any suitable fashion, and at any suitable location along its length (i.e., from immediately adjacent to the knot at the left atrial appendage to just proximal to, or just distal to, the skin surface). In some instances it may be desirable to sever the suture at the knot itself (e.g., in instances where it is desirable to release tension on the suture entirely). The suture may be severed in any suitable manner, such as for example by mechanically cutting, or by the application of energy. For example, the suture may be severed with the application of light energy, thermal energy, RF energy, electrical energy, magnetic energy, electromagnetic energy, kinetic energy, chemical energy, and combinations of any of the above.

[0177] Although the foregoing invention has, for the purposes of clarity and understanding been described in some detail by way of illustration and example, it will be apparent that certain changes and modifications may be practiced, and are intended to fall within the scope of the appended claims. Additionally, it should be appreciated that the closure devices described here may comprise any combination of device components and features described above.

CLAIMS

We claim:

1. A method of closing a target tissue comprising:
introducing a closure device into a body, wherein the closure device comprises a snare loop assembly having an opened configuration and a closed configuration and comprising a suture loop releasably coupled to the snare loop assembly;
advancing snare loop assembly to ensnare the target tissue;
closing the snare loop assembly around the target tissue;
applying a first predetermined tension to the suture loop to release the suture loop from the snare loop assembly; and
applying a second predetermined tension to the suture loop to tighten the suture loop around the target tissue.
2. The method of claim 1 wherein the target tissue is the left atrial appendage
3. The method of claim 1 further comprising opening the snare loop assembly to the open configuration after releasing the suture loop from the snare loop assembly.
4. The method of claim 1 further comprising re-tightening the suture loop after a first time period following applying the second predetermined tension to the suture loop.
5. The method of claim 4 wherein the first time period is at least thirty seconds.
6. The method of claim 4 wherein the first time period is at least two minutes.
7. The method of claim 4 wherein re-tightening the suture loop comprises applying a third predetermined tension to the suture loop.

8. The method of claim 4 wherein re-tightening the suture loop comprises applying the second predetermined tension to the suture loop.
9. The method of claim 1 wherein the second predetermined tension is greater than the first predetermined tension.
10. The method of claim 1 wherein the first predetermined tension is greater than the second predetermined tension.
11. The method of claim 1 wherein the first predetermined tension is at least about 6 pounds.
12. The method of claim 1 wherein the second predetermined tension is at least about 10 pounds.
13. The method of claim 1 wherein applying the first predetermined tension to the suture loop comprises applying the first predetermined tension to the suture loop using a first tensioning device.
14. The method of claim 13 wherein applying the second predetermined tension to the suture loop comprises applying the second predetermined tension to the suture loop using the first tensioning device.
15. The method of claim 13 wherein applying the second predetermined tension to the suture loop comprises applying the second predetermined tension to the suture loop using a second tensioning device.
16. The method of claim 13 wherein the tensioning device comprises a suture attachment mechanism for coupling the tensioning device to a portion of the suture loop, a force gauge, and a force indicator.
17. The method of claim 13 wherein the tensioning device comprises a rotation knob, a spooling member, a first clutch, and a second clutch.

18. The method of claim 13 wherein the tensioning device comprises a housing, a first extension member, and a first constant force spring attached to the housing and the first extension member.
19. A device for closing a tissue comprising:
 - a closure device comprising a snare loop assembly having a suture loop releasably coupled to the snare loop assembly; and
 - a tensioning device, wherein the tensioning device comprises a suture attachment mechanism for coupling the tensioning device to a portion of the suture loop, a force gauge, and a force indicator.
20. The device of claim 19 wherein a tail of the suture loop is connected to a suture fob, and the suture attachment mechanism comprises an aperture sized and shaped to receive and hold the suture fob.
21. The device of claim 19 wherein the force indicator comprises a digital display.
22. A device for closing a tissue comprising:
 - a closure device comprising a snare loop assembly and a handle, wherein the snare loop assembly comprises suture loop releasably coupled to the snare loop assembly; and
 - a tensioning device, wherein the tensioning device comprises a base, a rotation knob, a spooling member, a first clutch, and a second clutch.
23. The device of claim 22 wherein the base of the tensioning device is attached to the handle of the closure device.
24. The device of claim 22 wherein the rotation knob comprises a switch and an engagement rod, and wherein the switch is moveable between a first position in which the engagement rod may rotate relative to the second clutch, and second position in

which the engagement rod engages second clutch is rotatably connected to the second clutch.

25. The device of claim 22 wherein a portion of the suture loop is coupled to the spooling member.

26. A system for closing a tissue comprising:

a closure device comprising a snare loop assembly having a suture loop releasably coupled to the snare loop assembly; and

a tensioning device, wherein the tensioning device comprises a housing; a first extension member slidable relative to housing; a first constant force spring attached to the housing and the first extension member and a suture attachment mechanism for coupling the tensioning device to a portion of the suture loop.

27. The device of claim 26 further comprising a second extension member and a second constant force spring, wherein the second constant force spring is attached to the housing and the second extension member.

28. The device of claim 27 wherein the first extension member is releasably couplable to the second extension member.

29. A device for closing a tissue comprising:

a closure device comprising a handle and a snare loop assembly having a suture loop releasably coupled to the snare loop assembly; and

a tensioning mechanism, wherein the tensioning mechanism comprises a rotation knob, an indicator body, and a spring member rotatably connecting the rotation knob and the indicator body, wherein rotation of the rotation knob tightens the suture loop, and wherein rotation of the rotation knob relative to the indicator body indicates an amount of force applied to the suture loop.

30. The device of claim 29 further comprising an axle, wherein the indicator body and axle are fixedly connected and wherein the indicator body and axle are rotatably coupled to the handle.
31. The device of claim 30 further comprising a spool, wherein rotation of the axle rotates the spool.
32. The device of claim 29 wherein the indicator body comprises at least one marking, the rotation knob comprises at least one marking, and the relative positioning between the at least one marking of the indicator body and the at least one marking of the rotation knob indicate an amount of force applied to the suture loop.

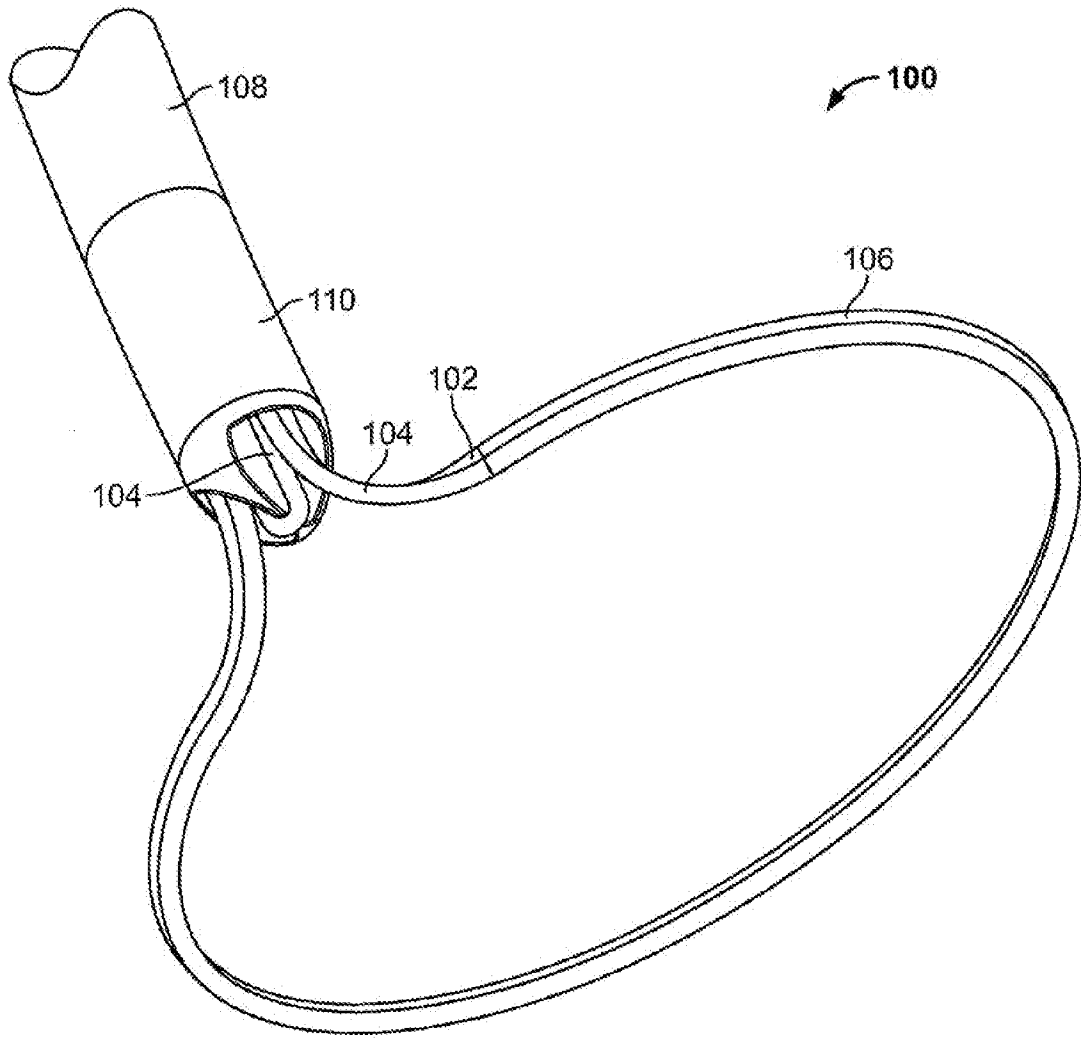

FIG. 1

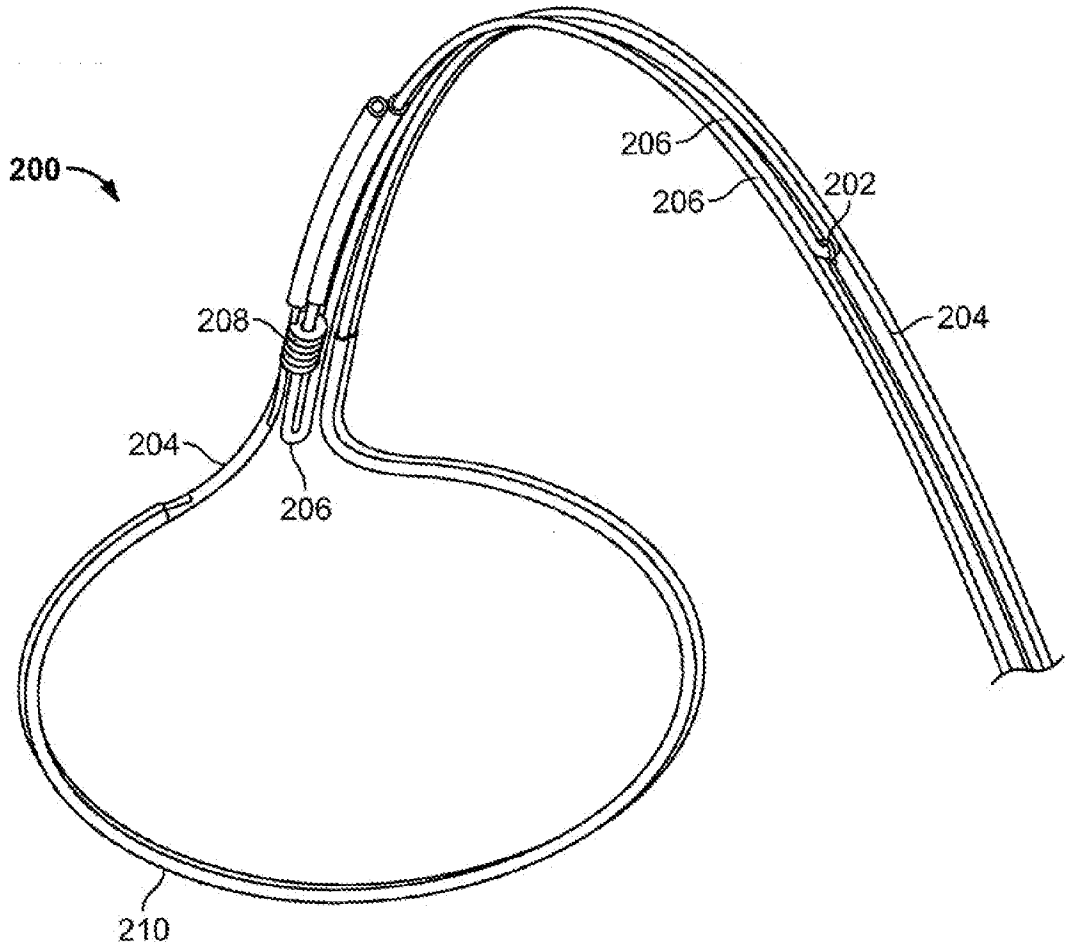
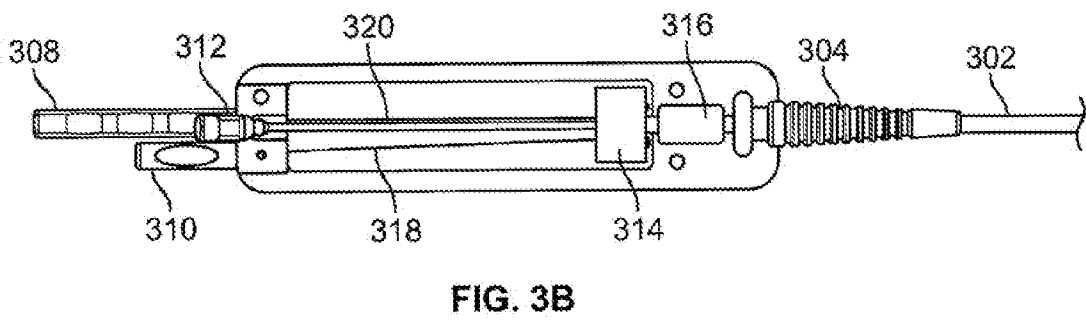
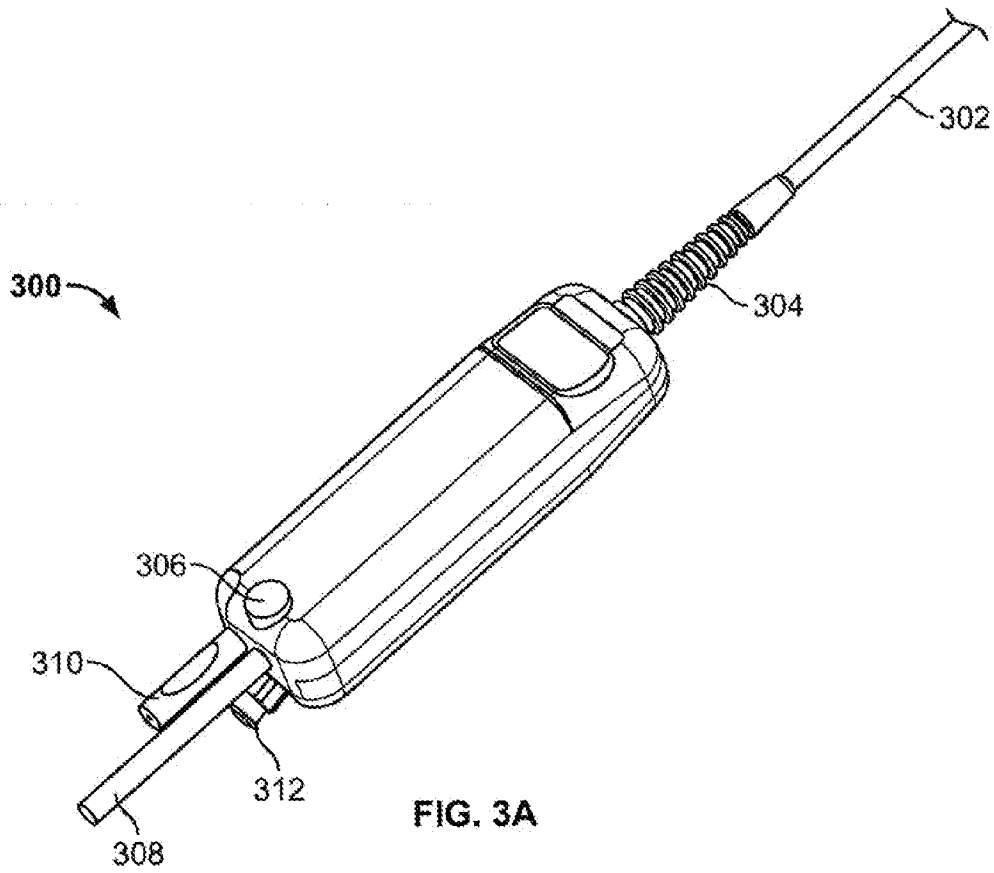

FIG. 2



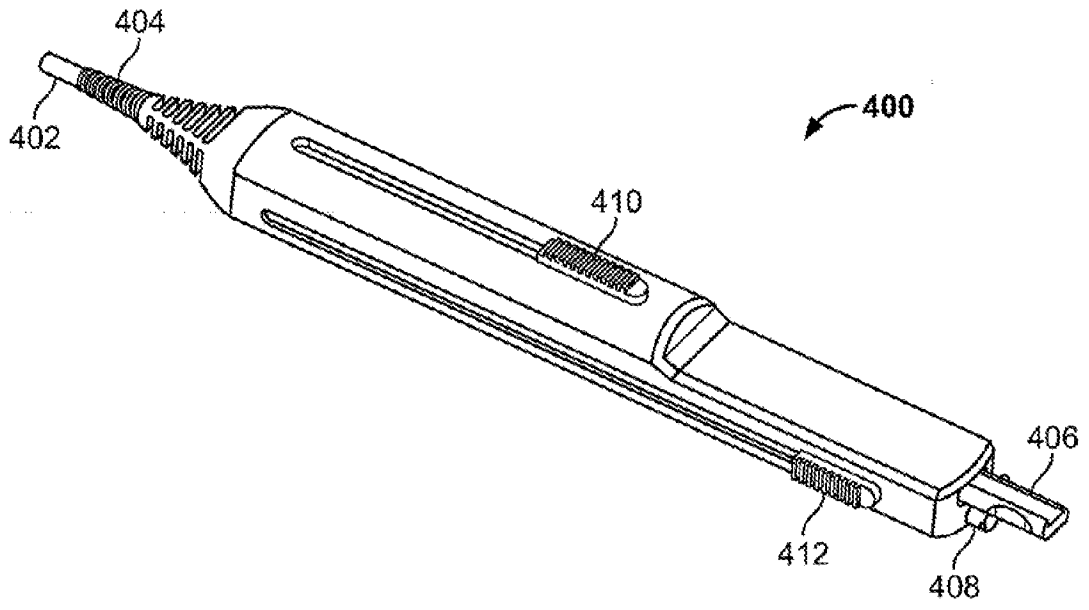

FIG. 4

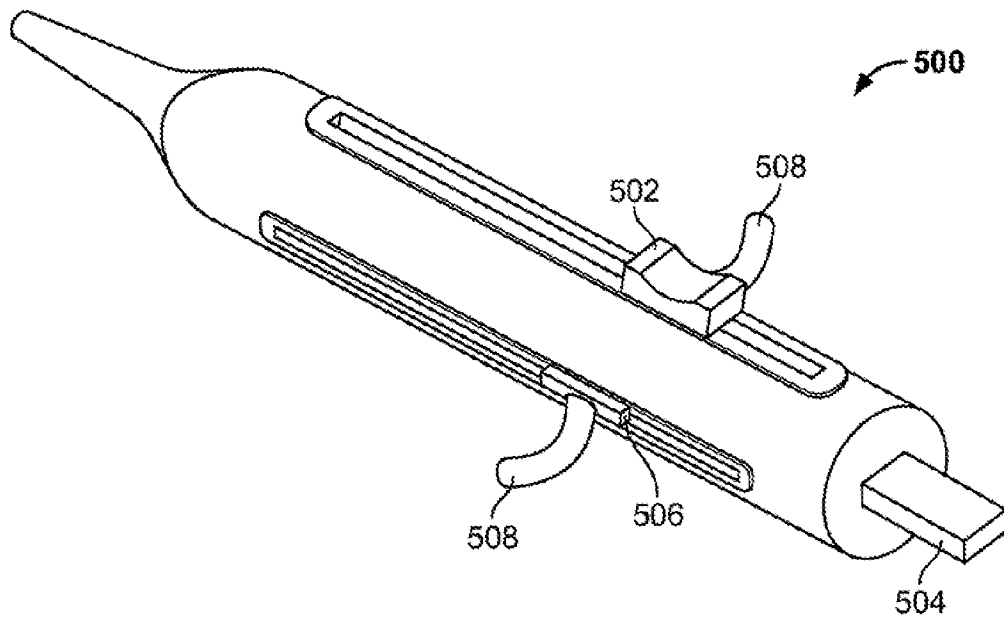

FIG. 5

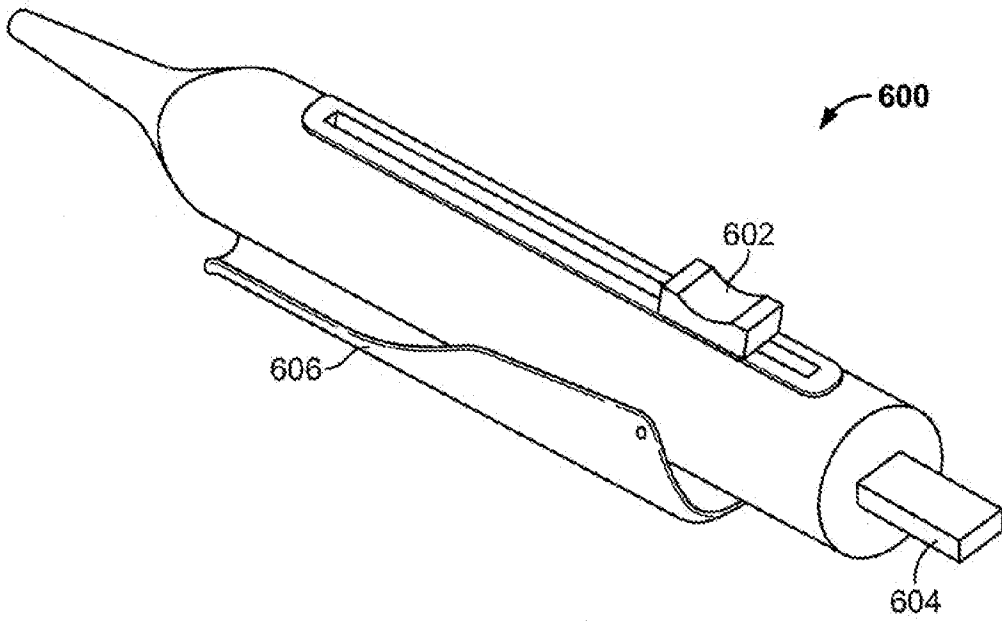

FIG. 6

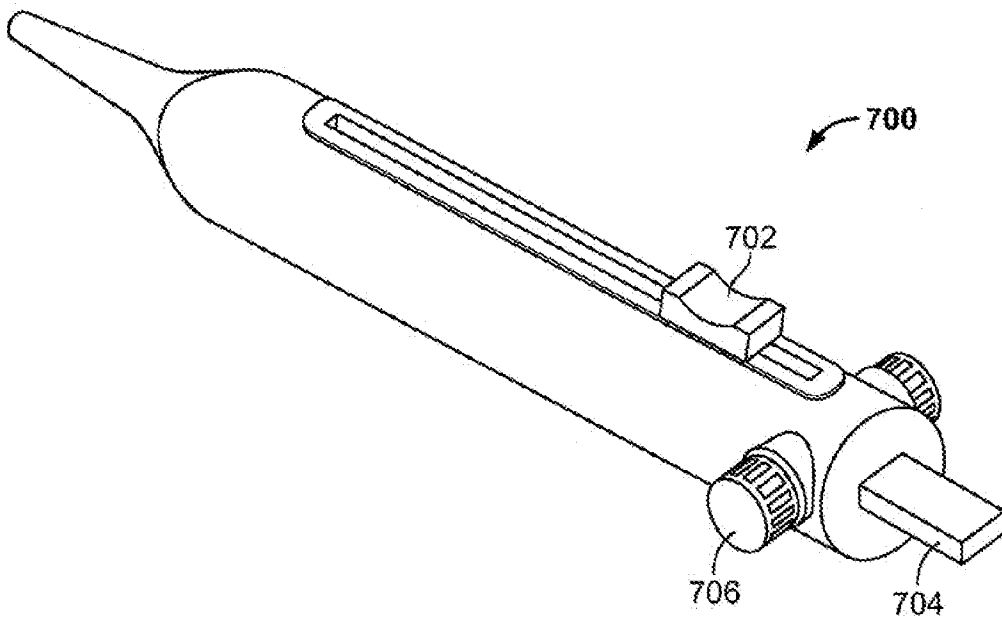

FIG. 7

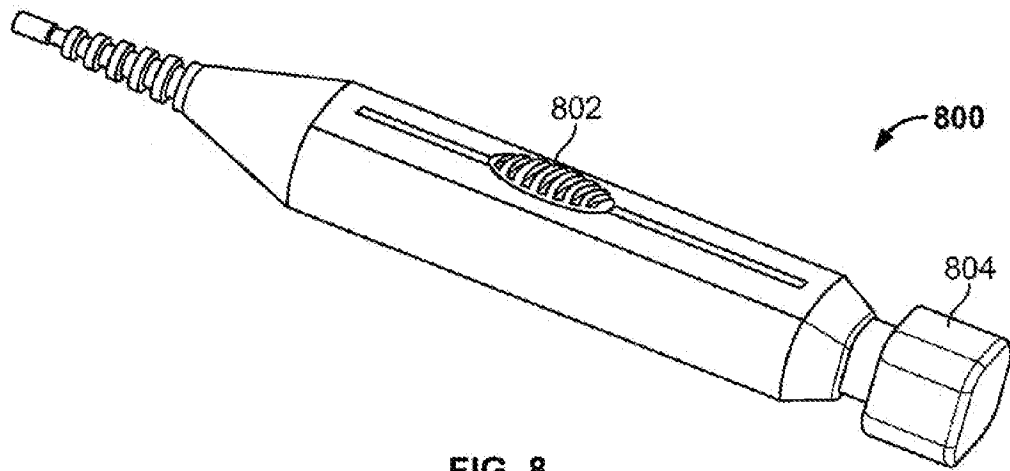

FIG. 8

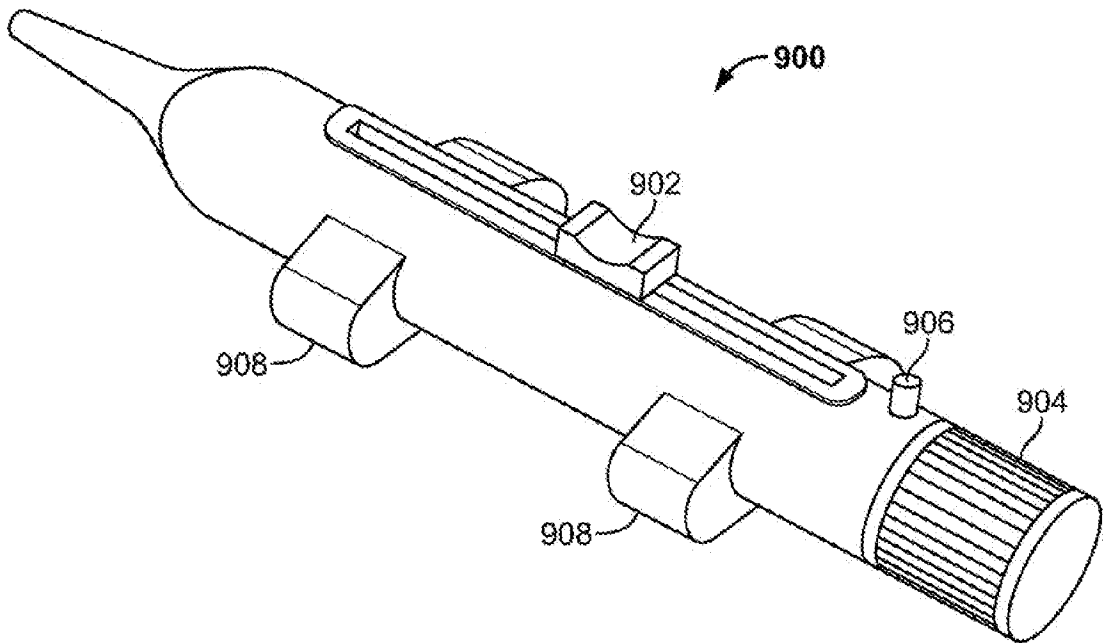

FIG. 9

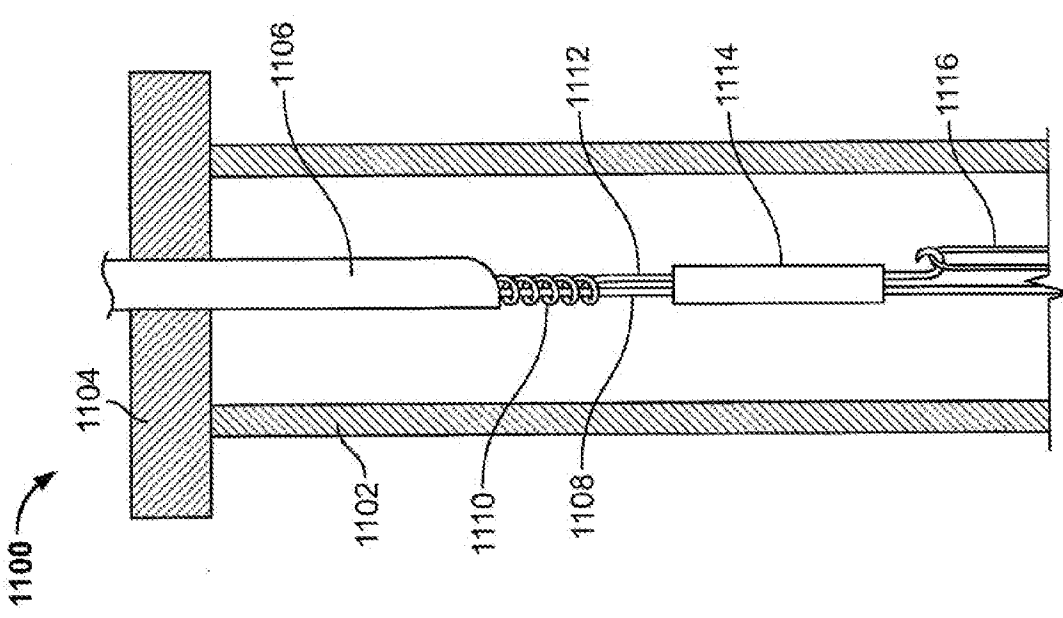

FIG. 11

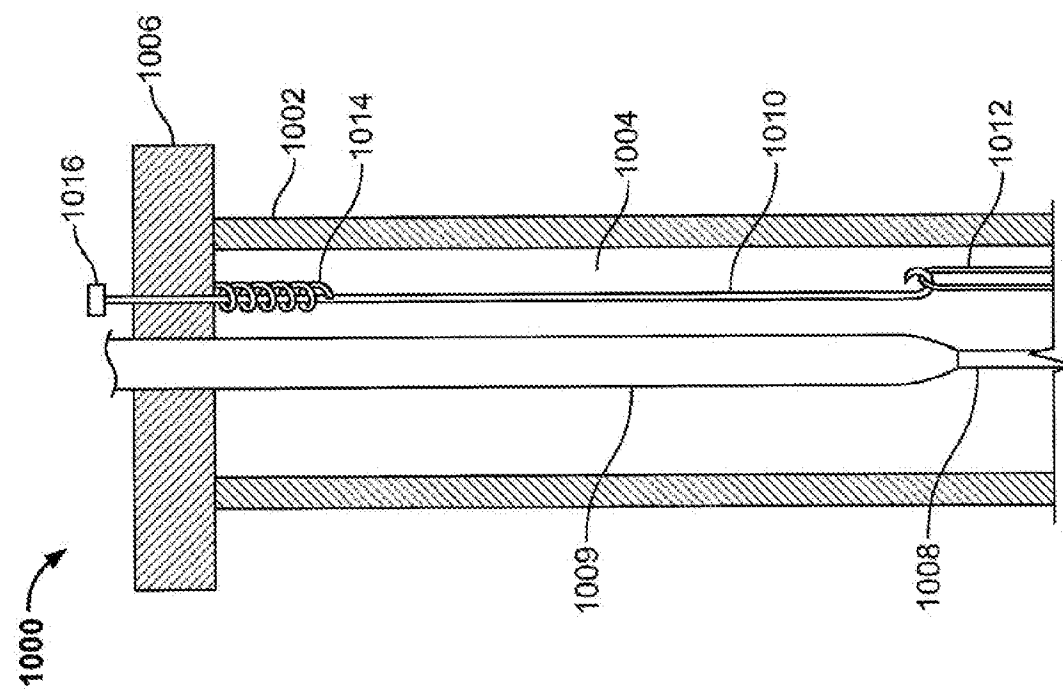

FIG. 10

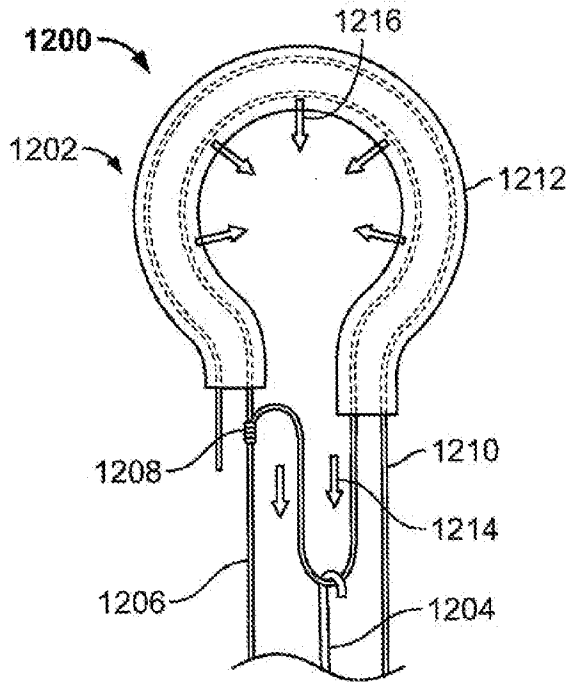

FIG. 12

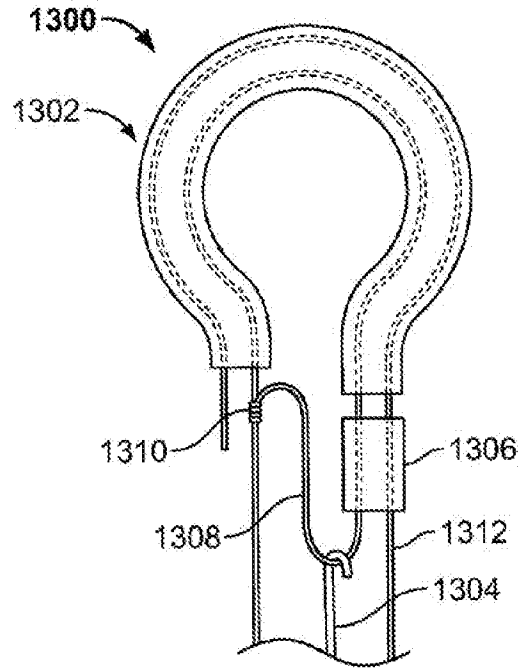

FIG. 13A

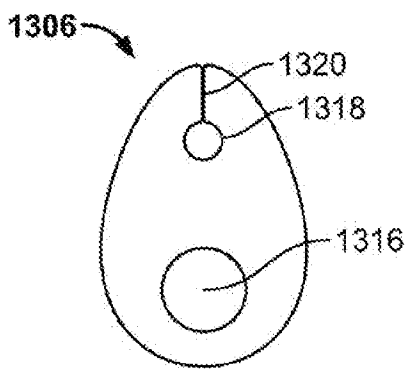

FIG. 13B

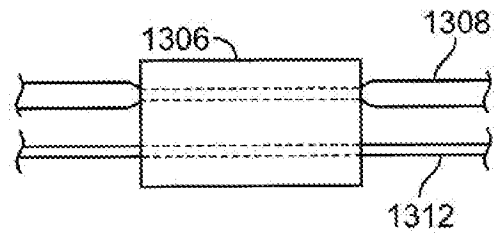

FIG. 13C

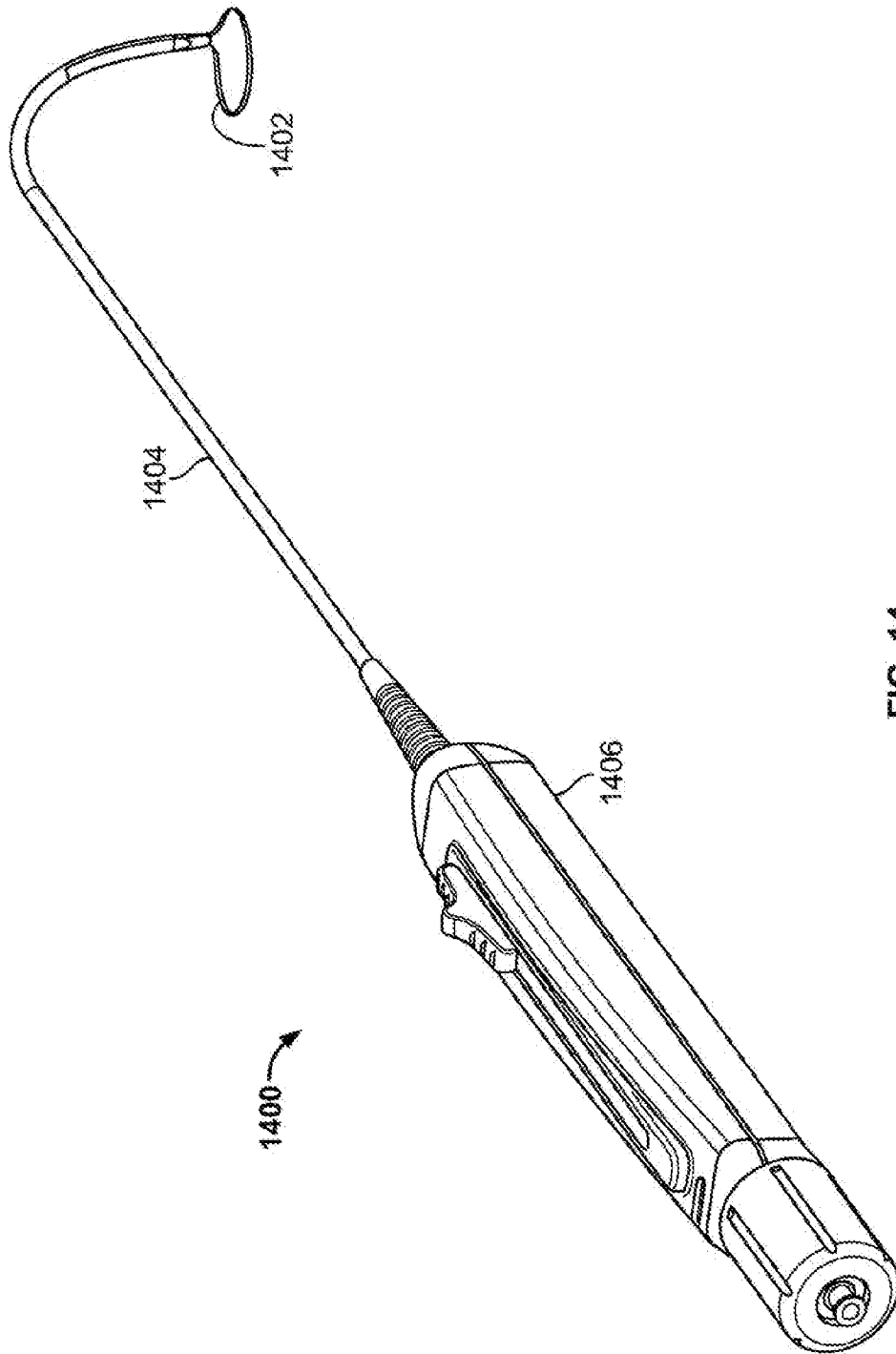

FIG. 14

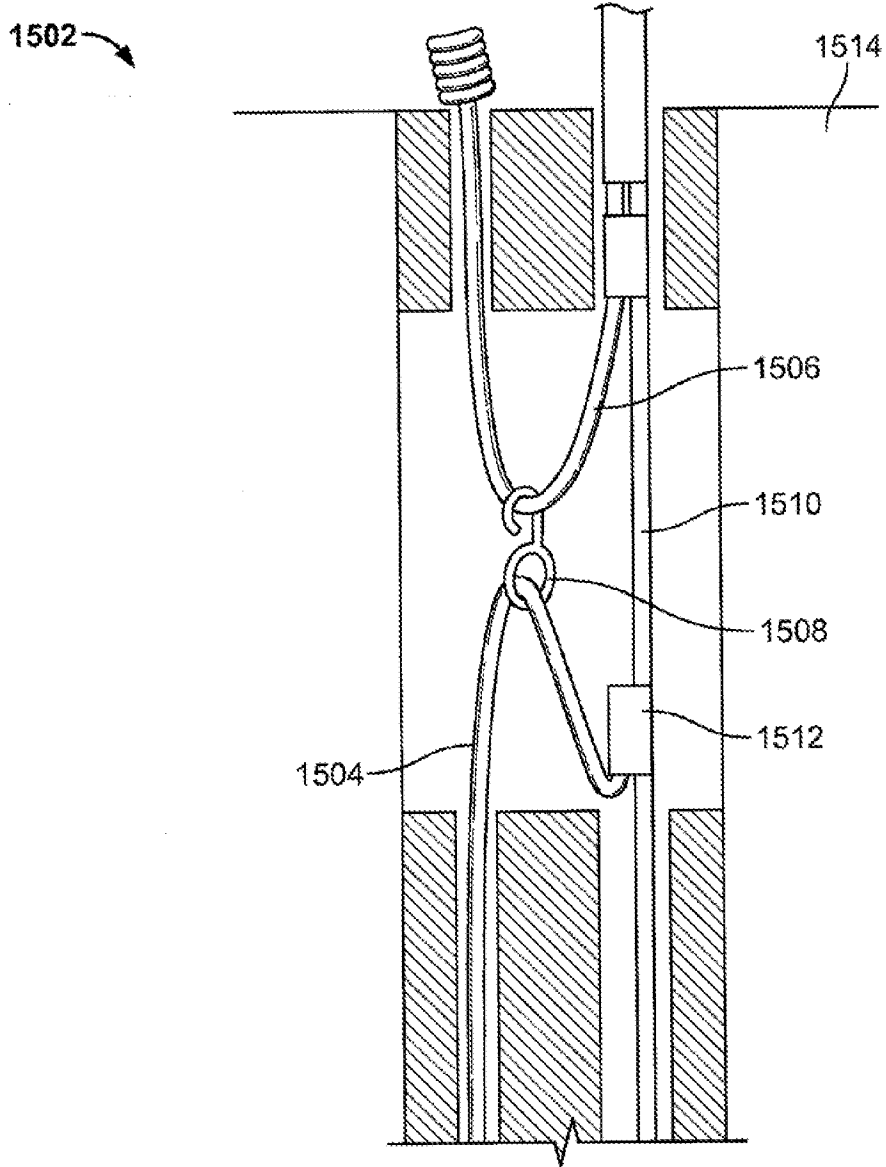

FIG. 15

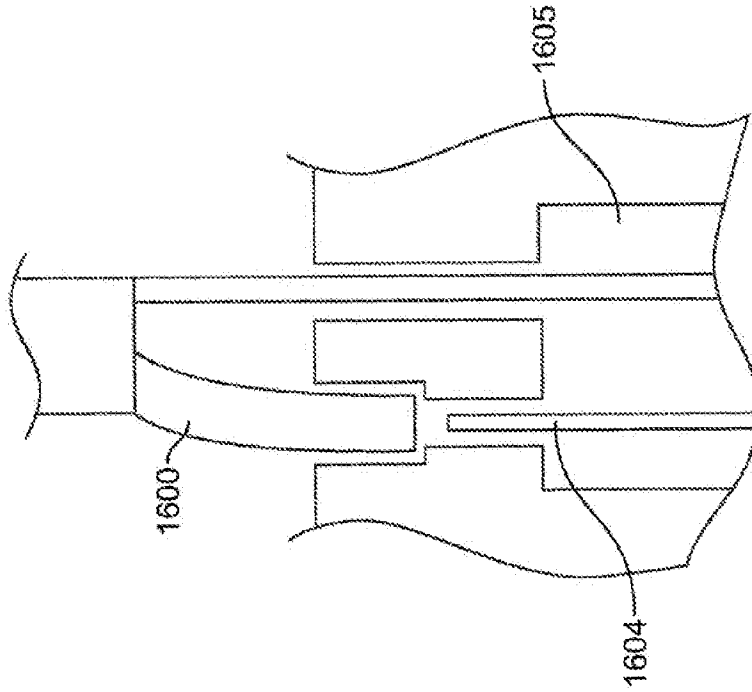

FIG. 16B

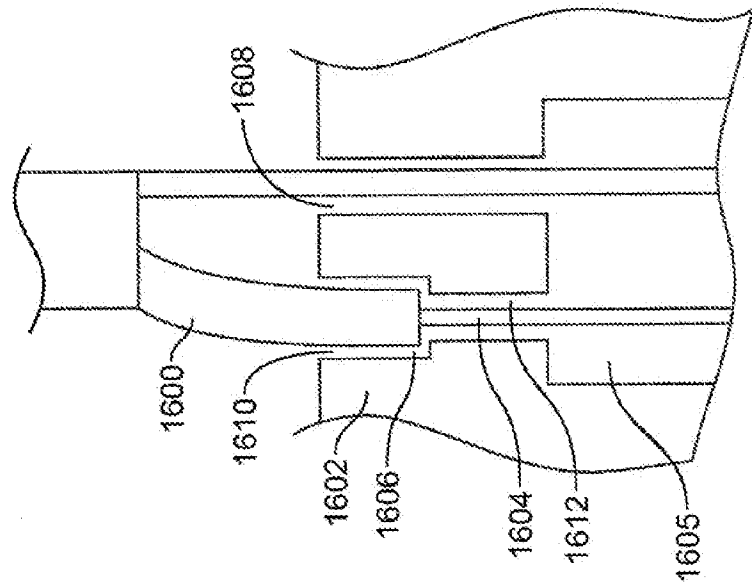

FIG. 16A

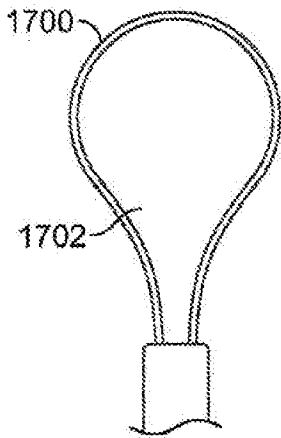

FIG. 17A

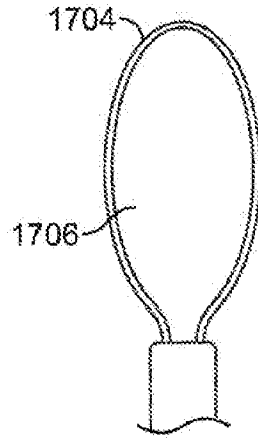

FIG. 17B

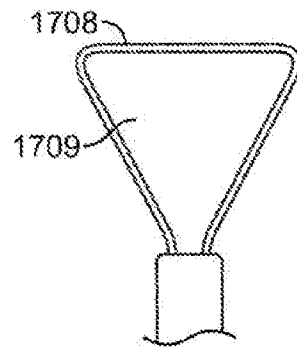

FIG. 17C

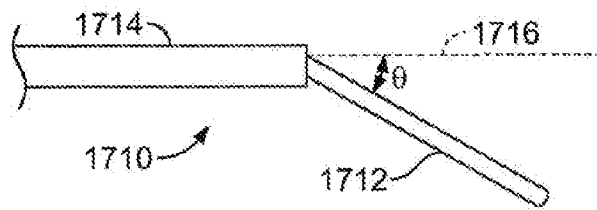

FIG. 17D

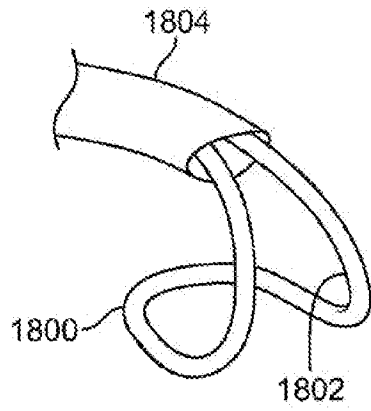

FIG. 18A

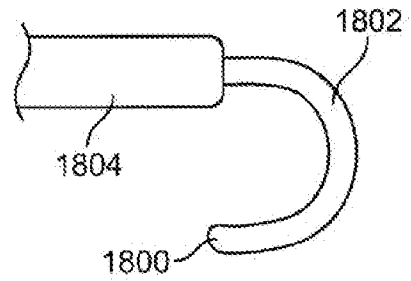

FIG. 18B

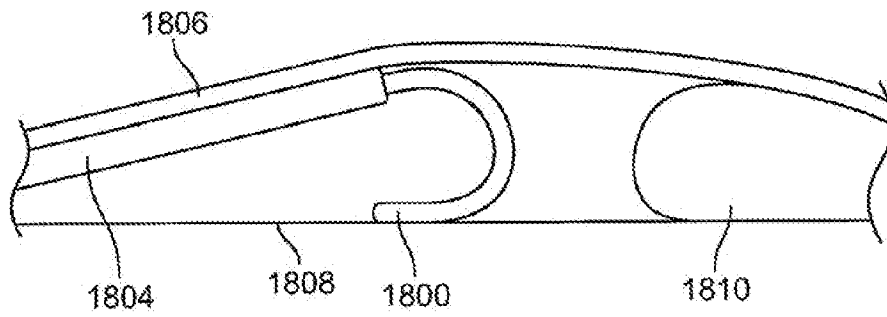

FIG. 18C

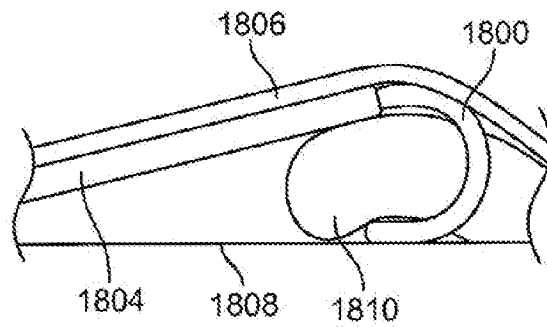

FIG. 18D

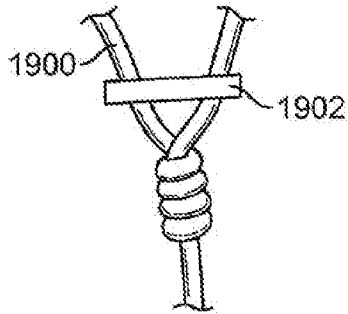

FIG. 19A

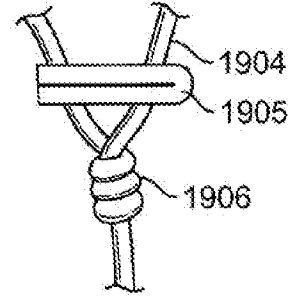

FIG. 19B

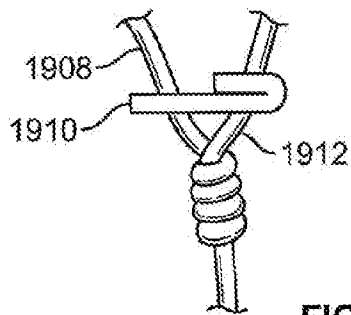

FIG. 19C

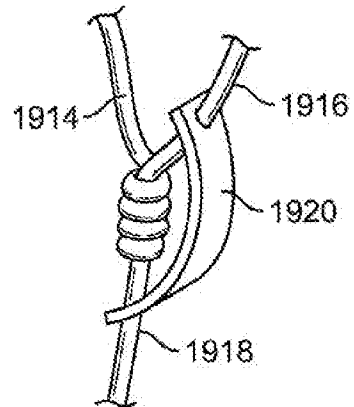

FIG. 19D

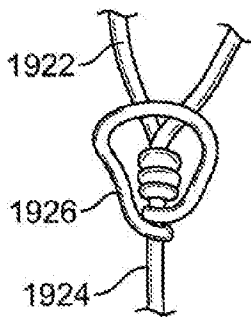

FIG. 19E

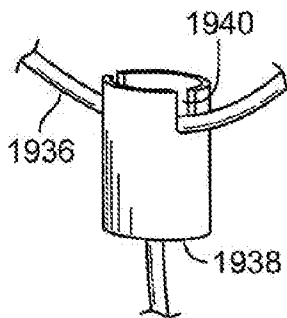

FIG. 19G

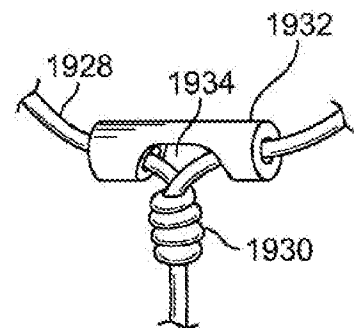
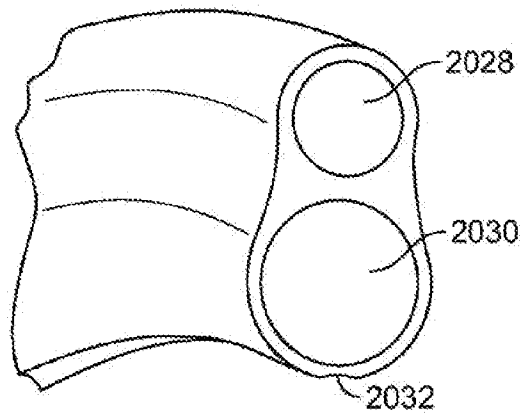
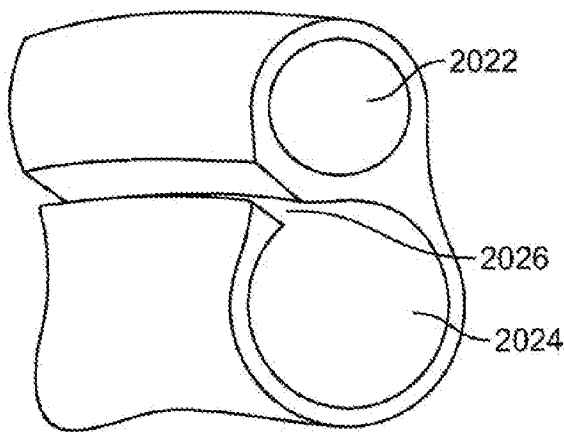
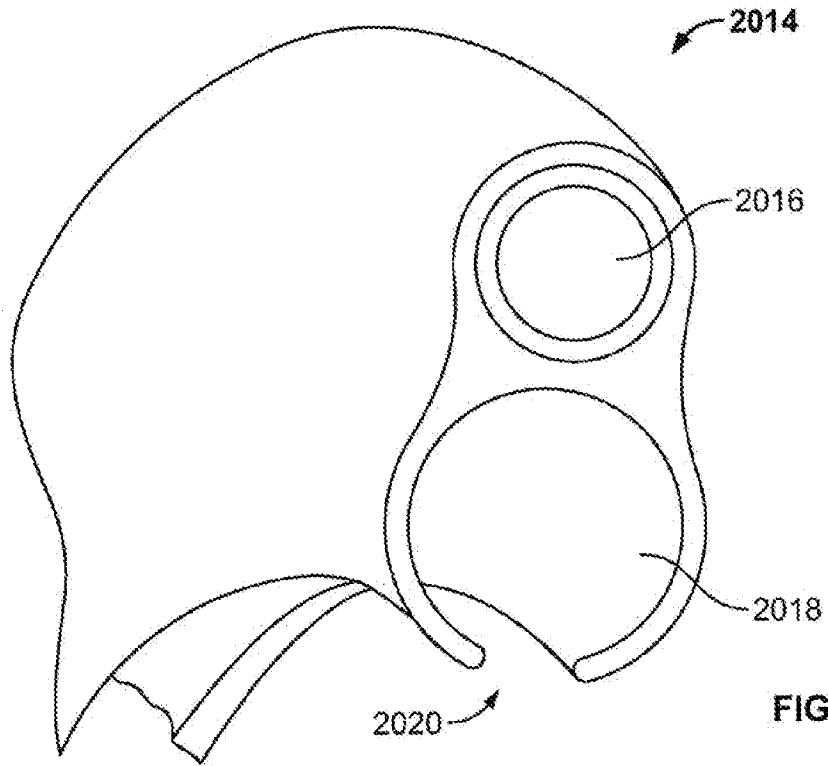

FIG. 19F



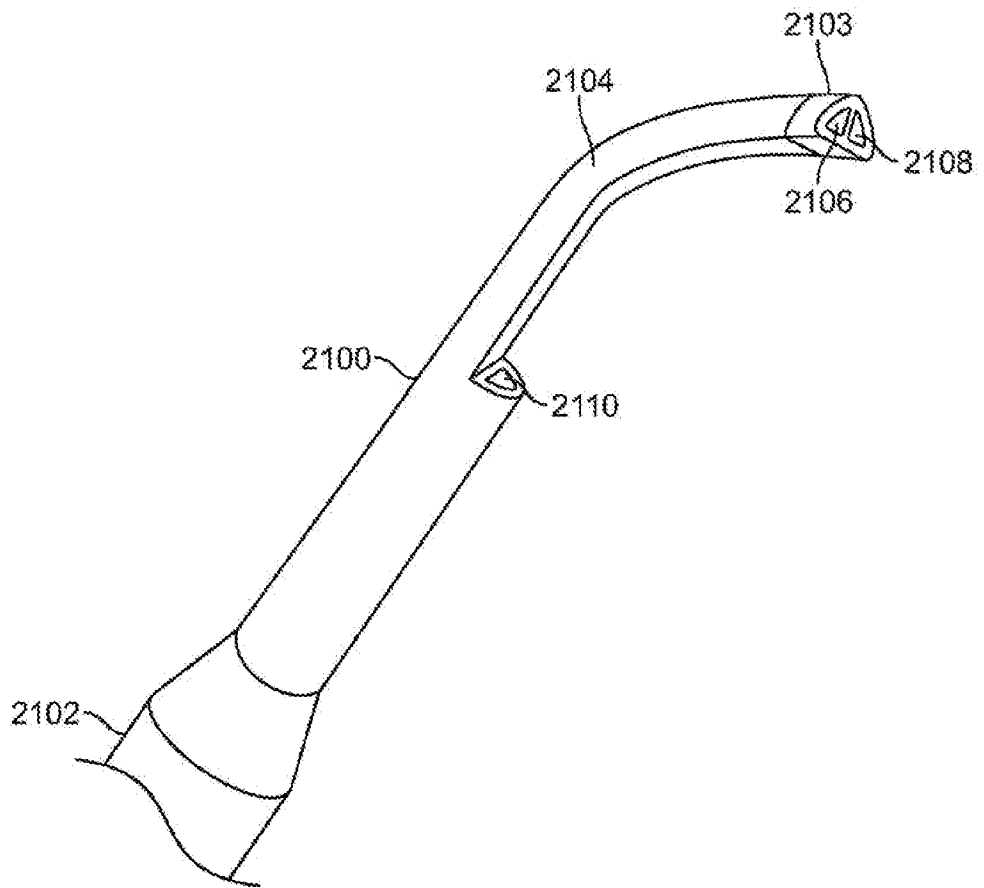

FIG. 21

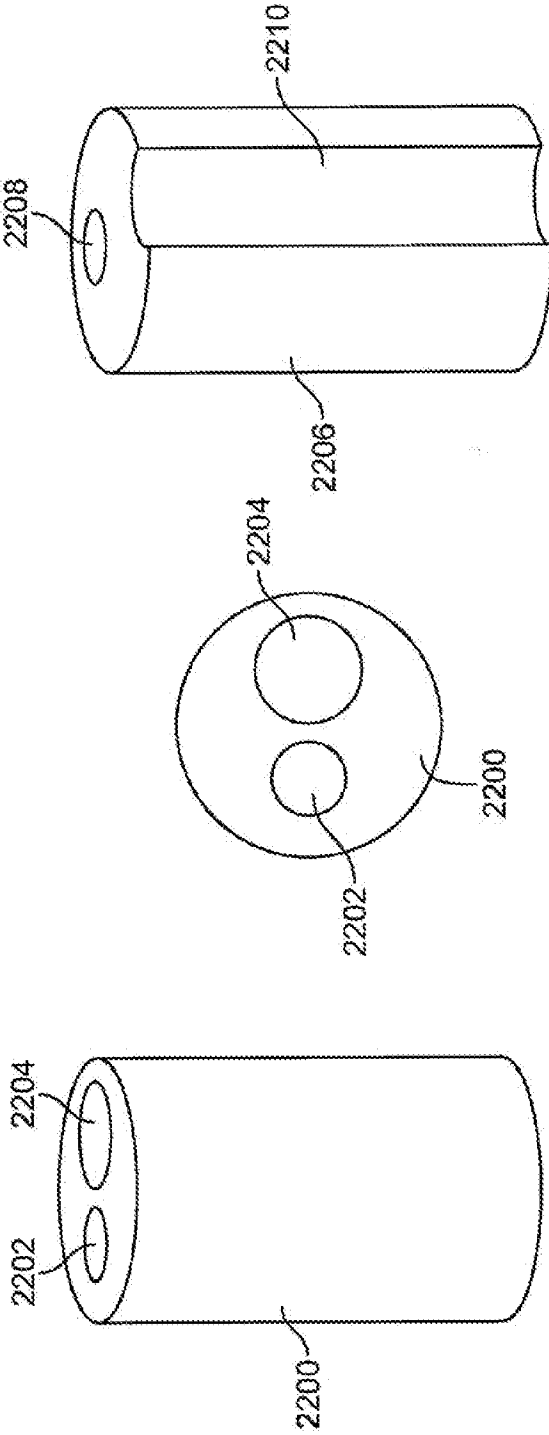

FIG. 22C

FIG. 22B

FIG. 22A

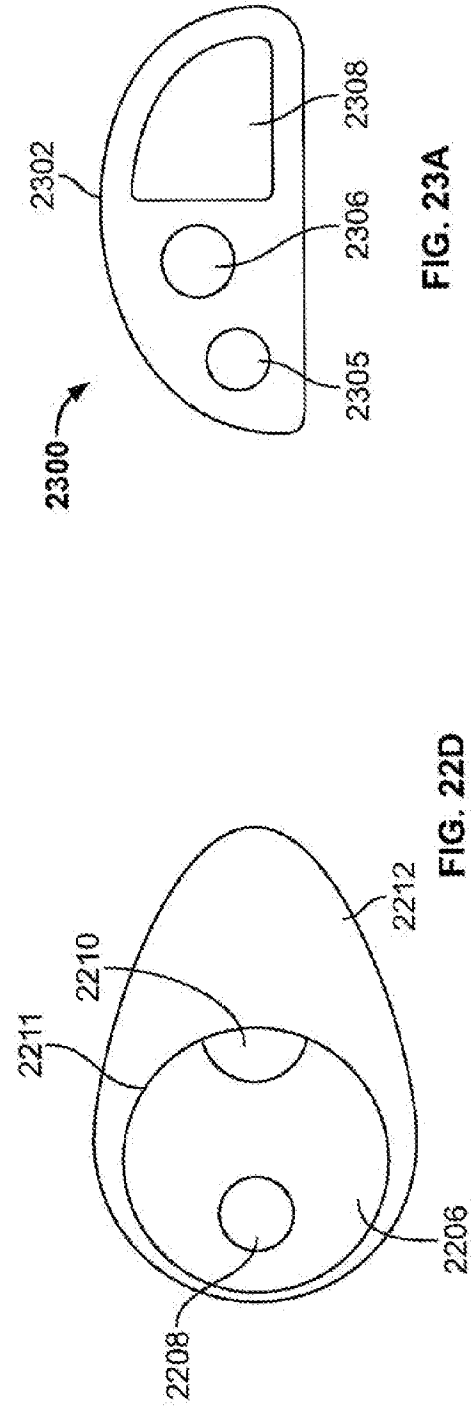

FIG. 23A

FIG. 22D

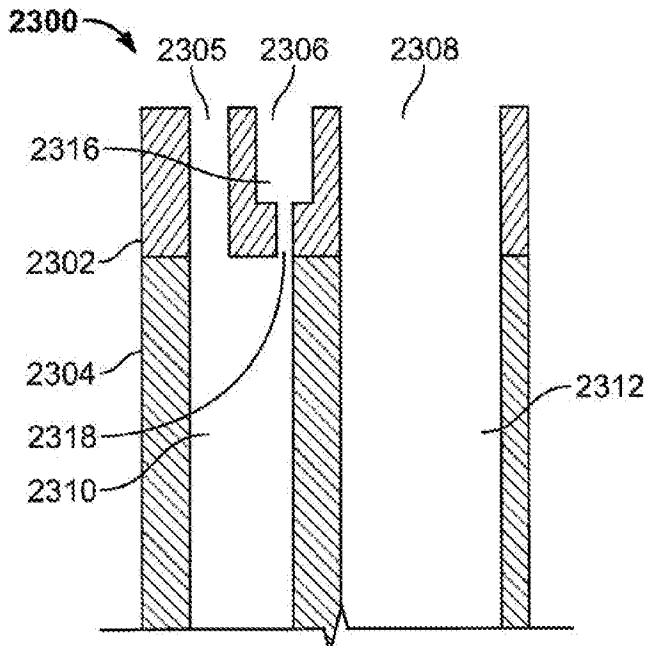

FIG. 23B

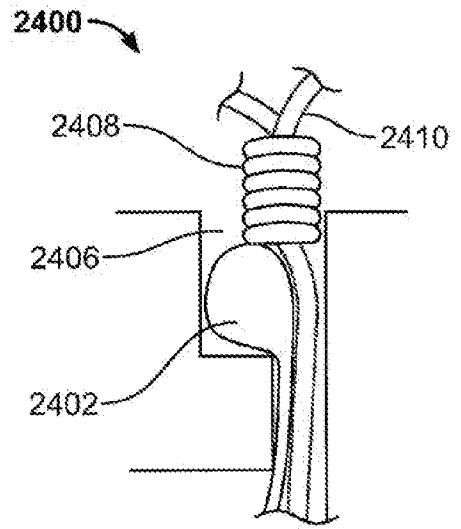

FIG. 24A

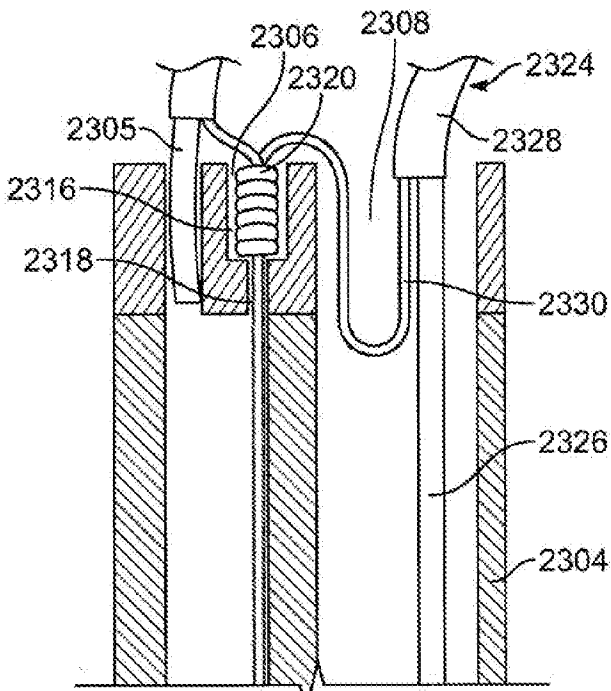

FIG. 23C

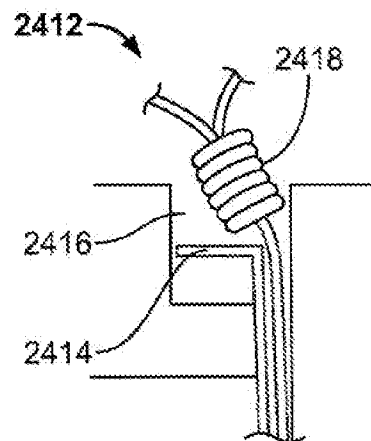

FIG. 24B

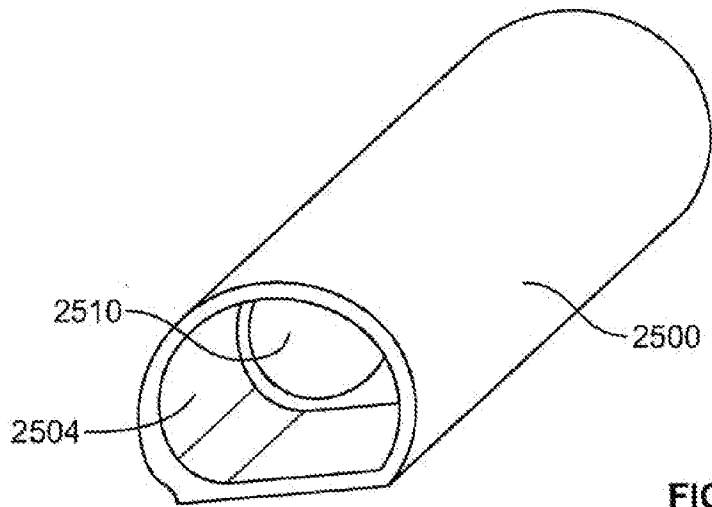

FIG. 25A

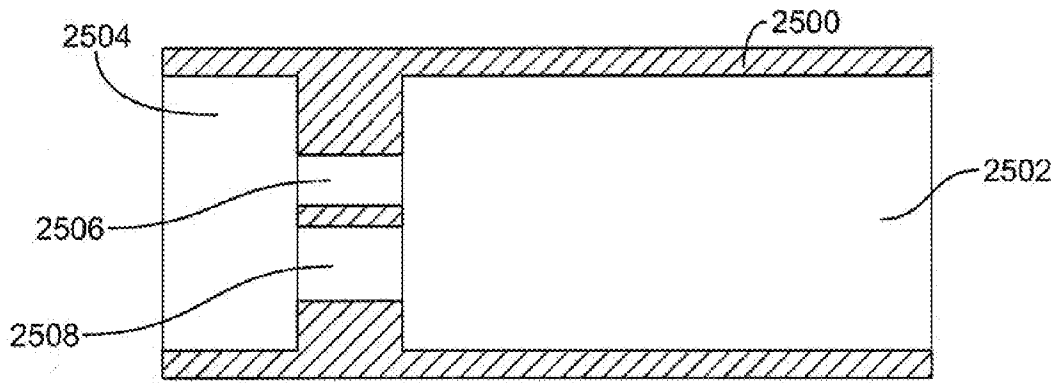

FIG. 25B

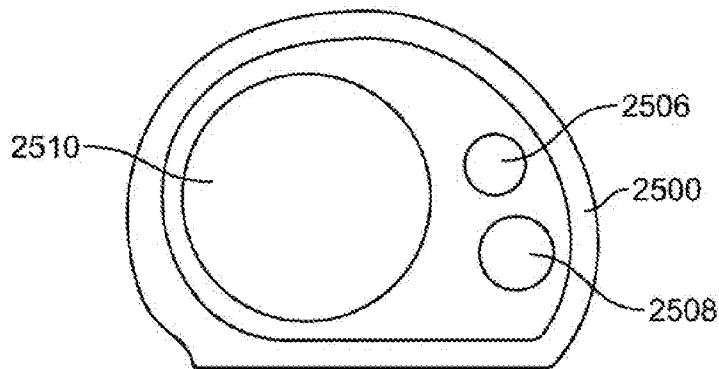

FIG. 25C

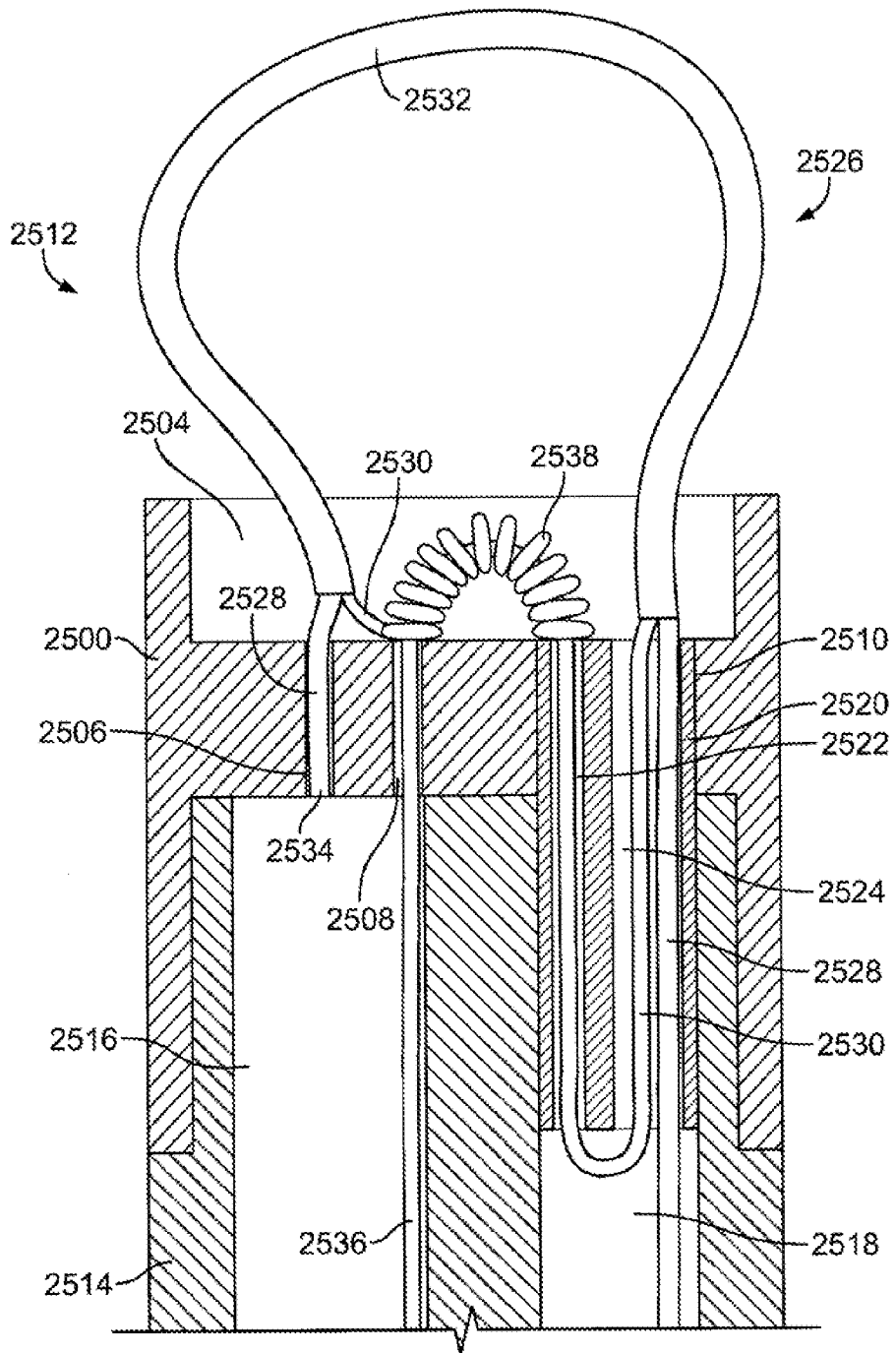

FIG. 25D

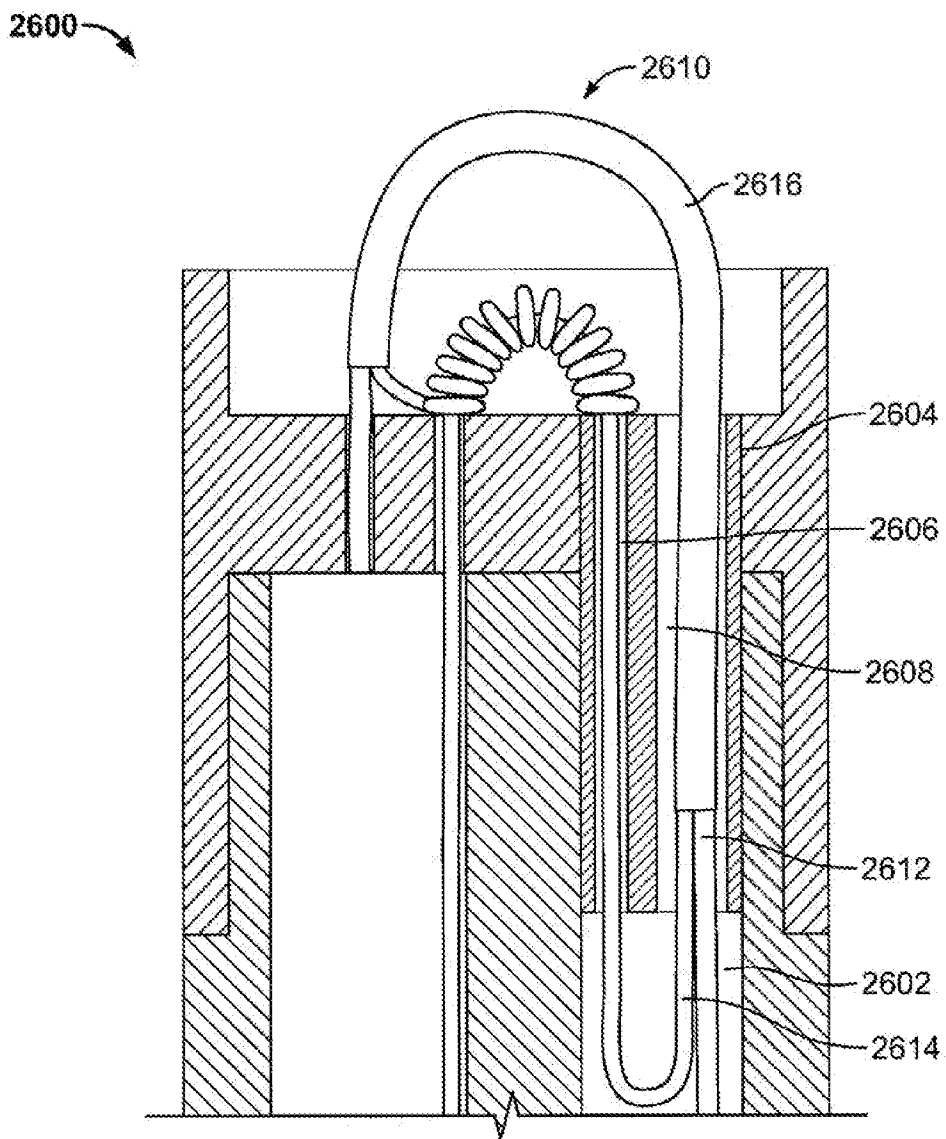

FIG. 26A

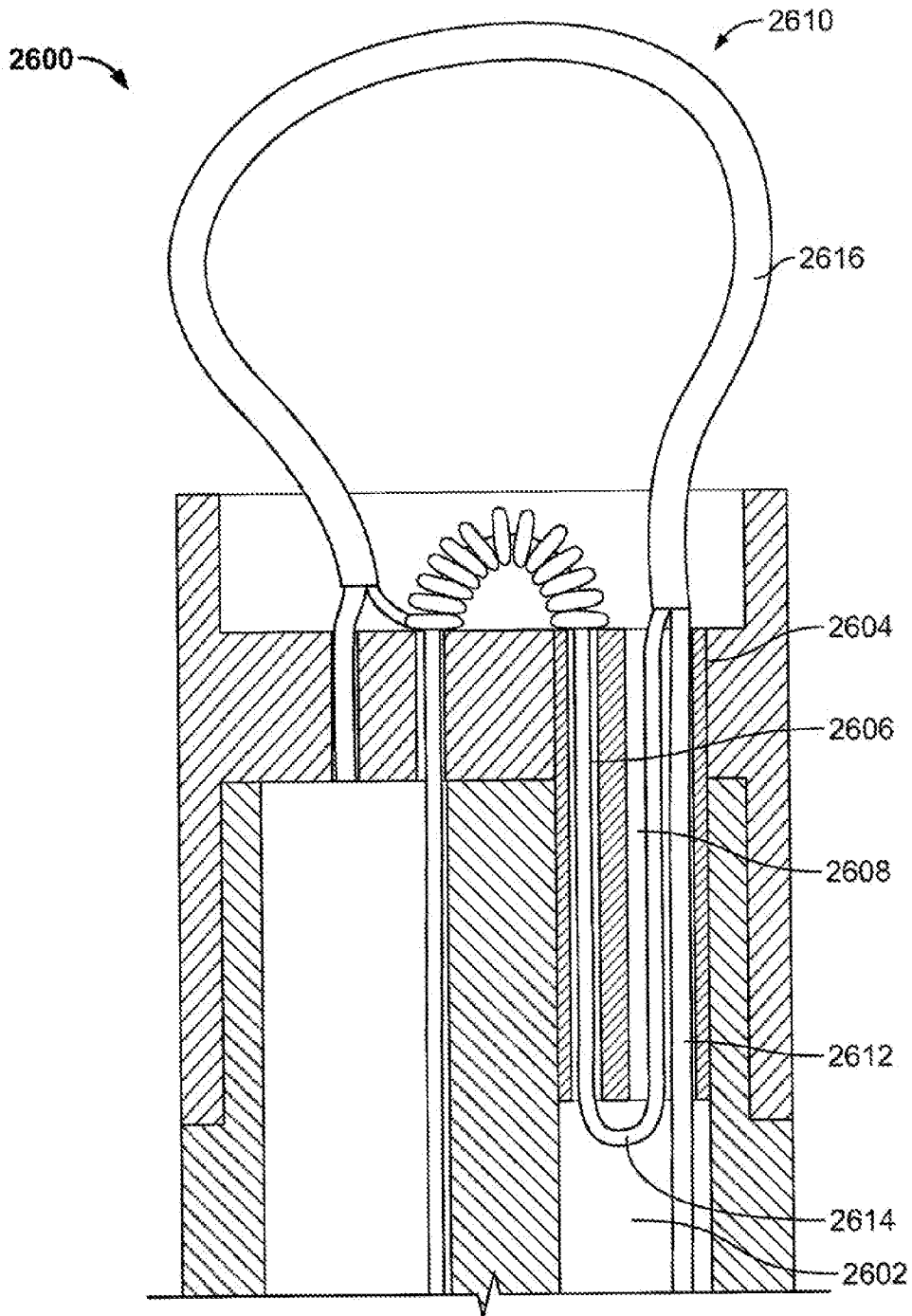
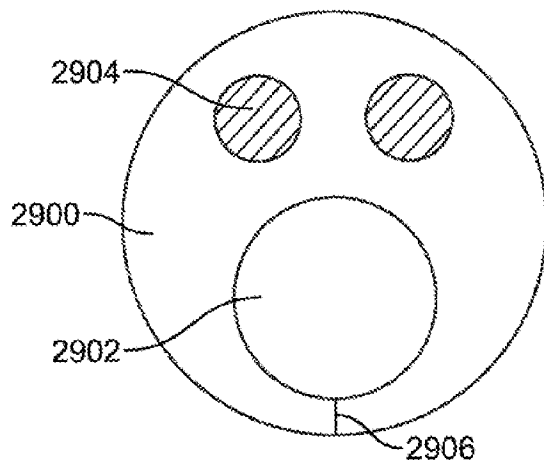
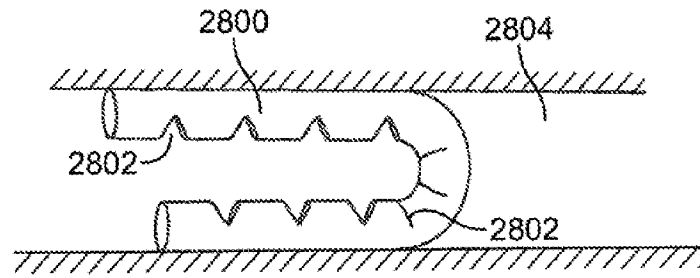
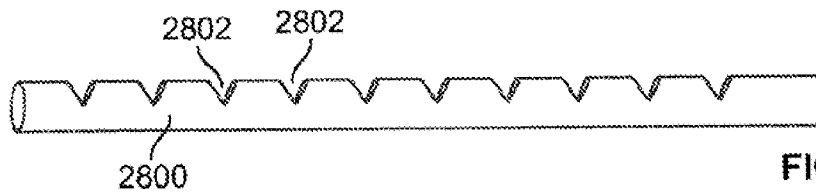
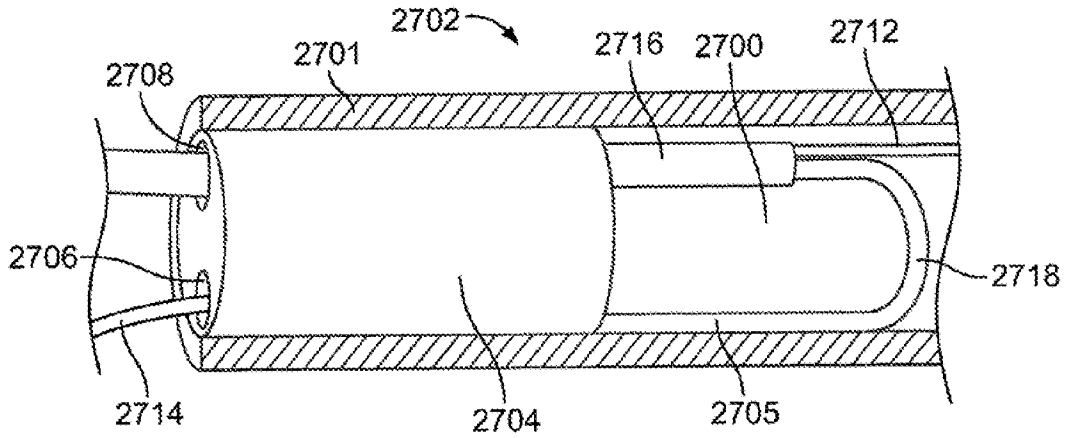

FIG. 26B



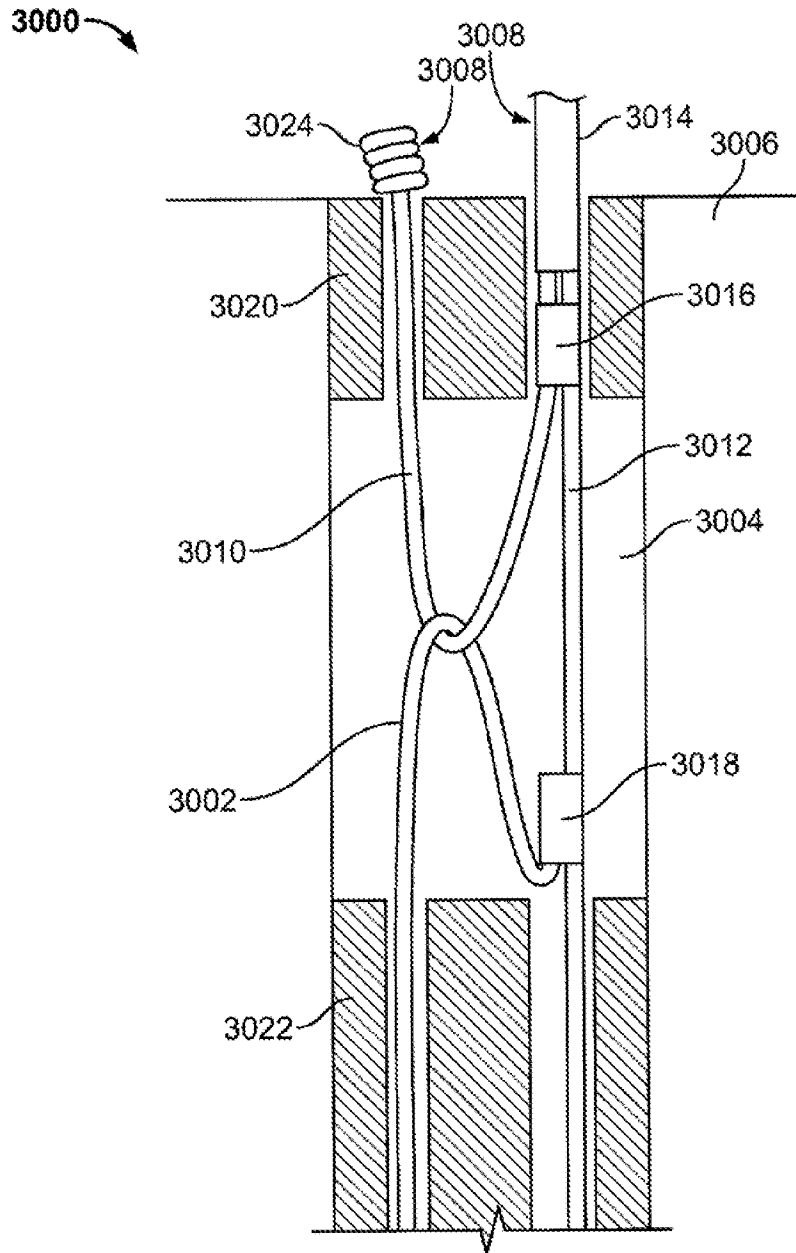

FIG. 30A

3000 ↘

3000 ↘

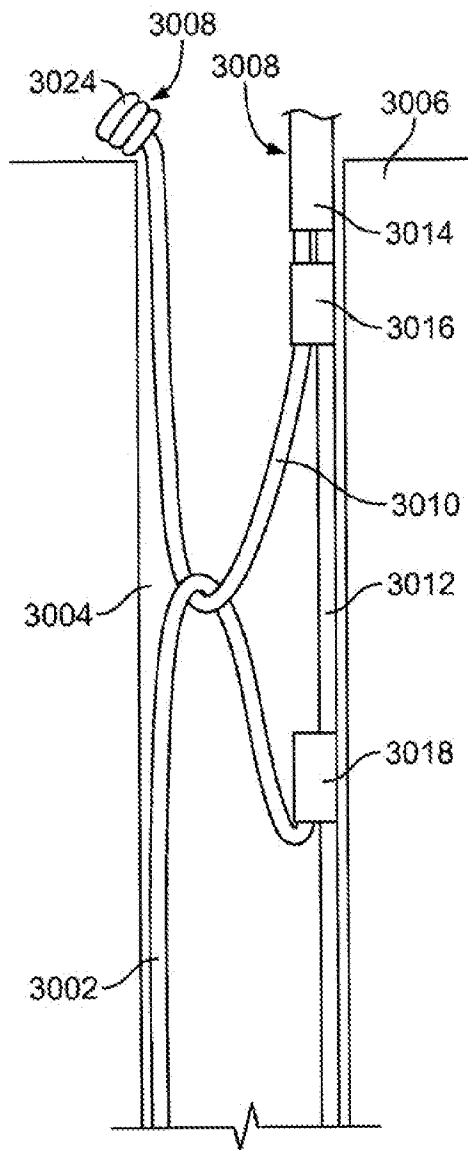

FIG. 30B

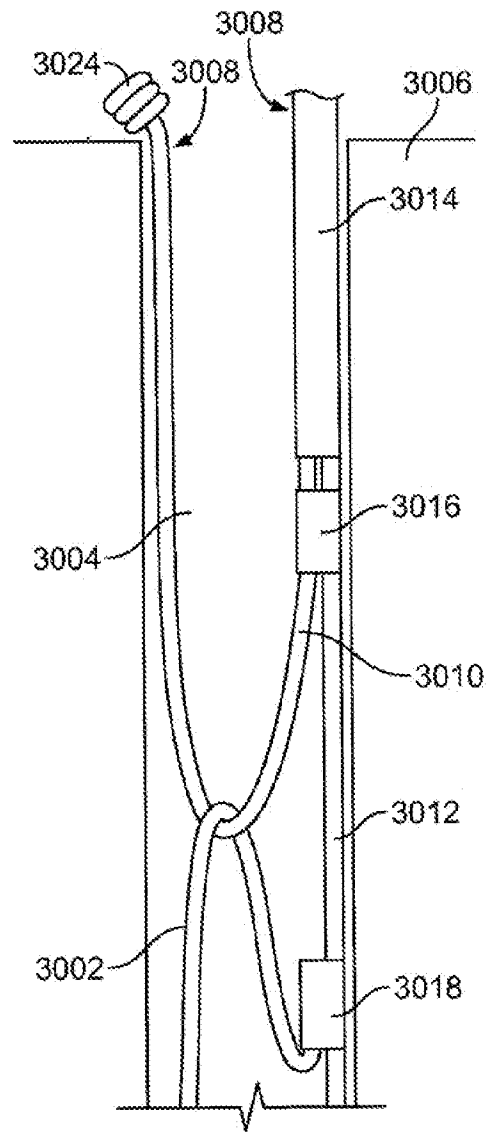

FIG. 30C

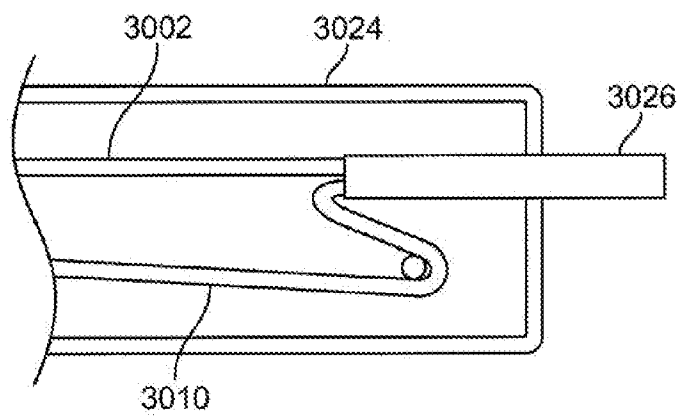

FIG. 30D

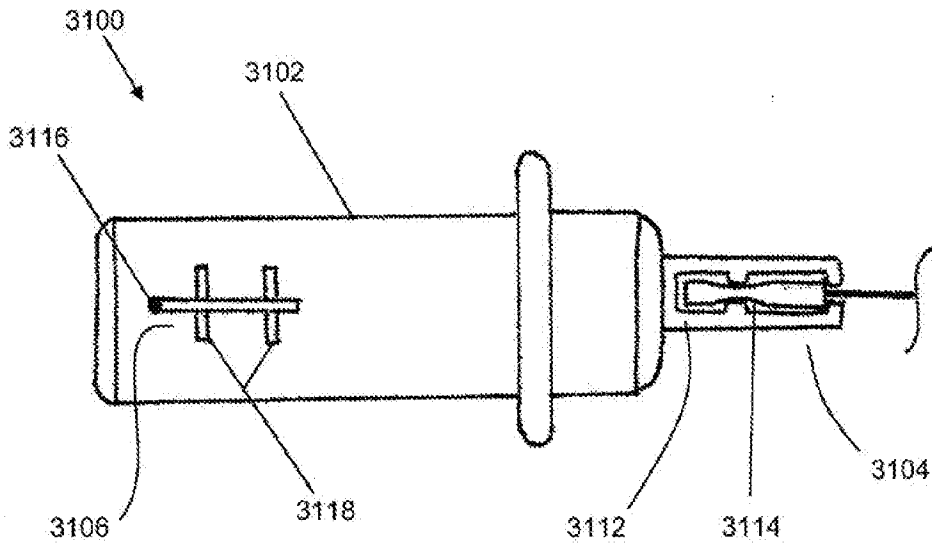

FIG. 31A

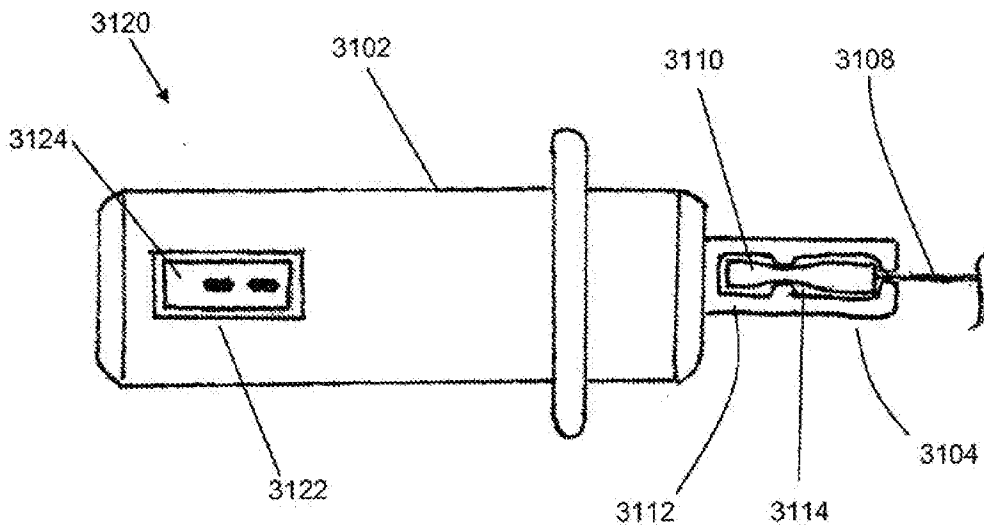

FIG. 31B

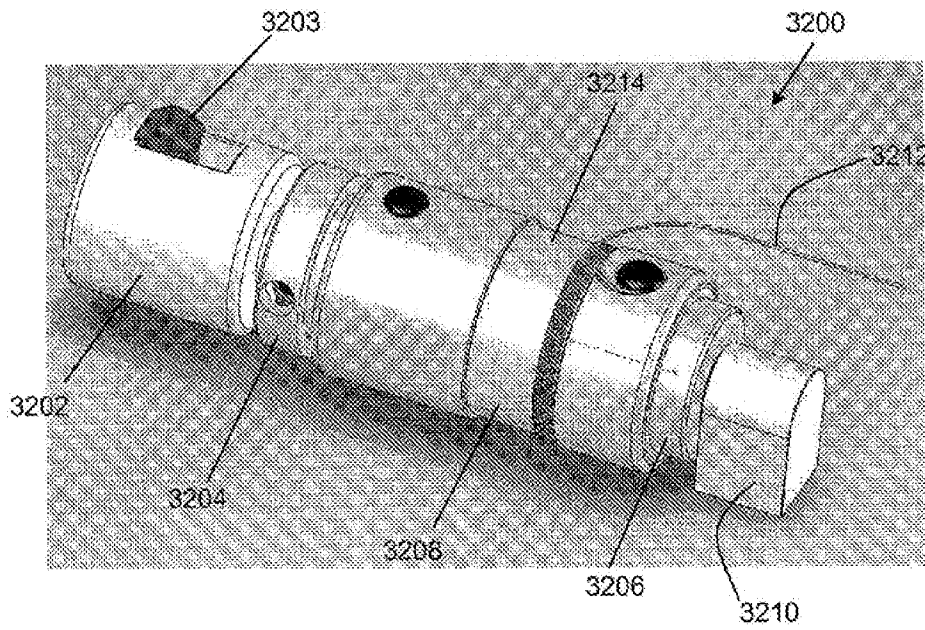

FIG. 32A

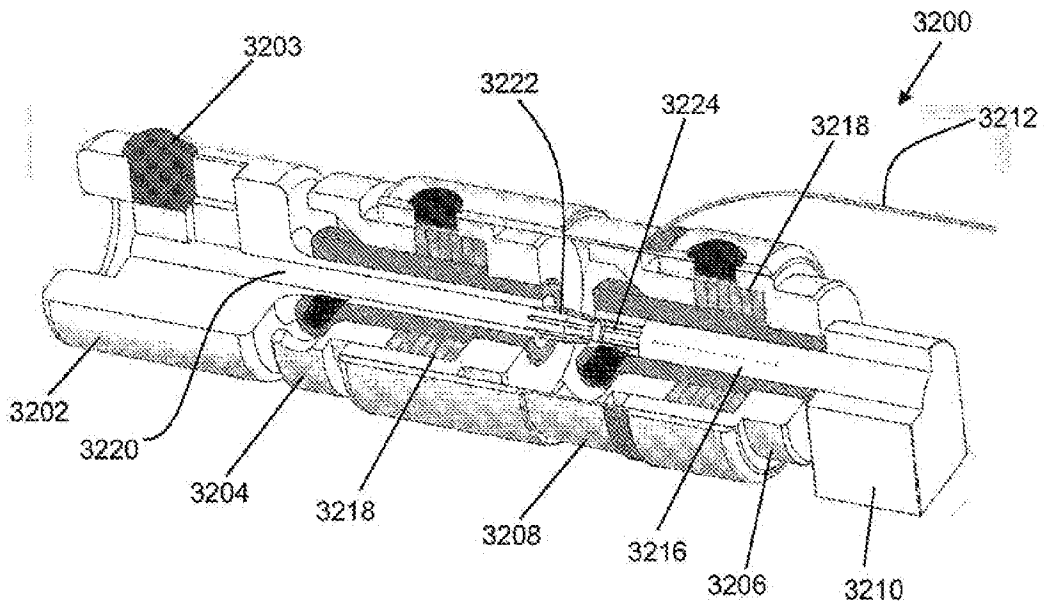

FIG. 32B

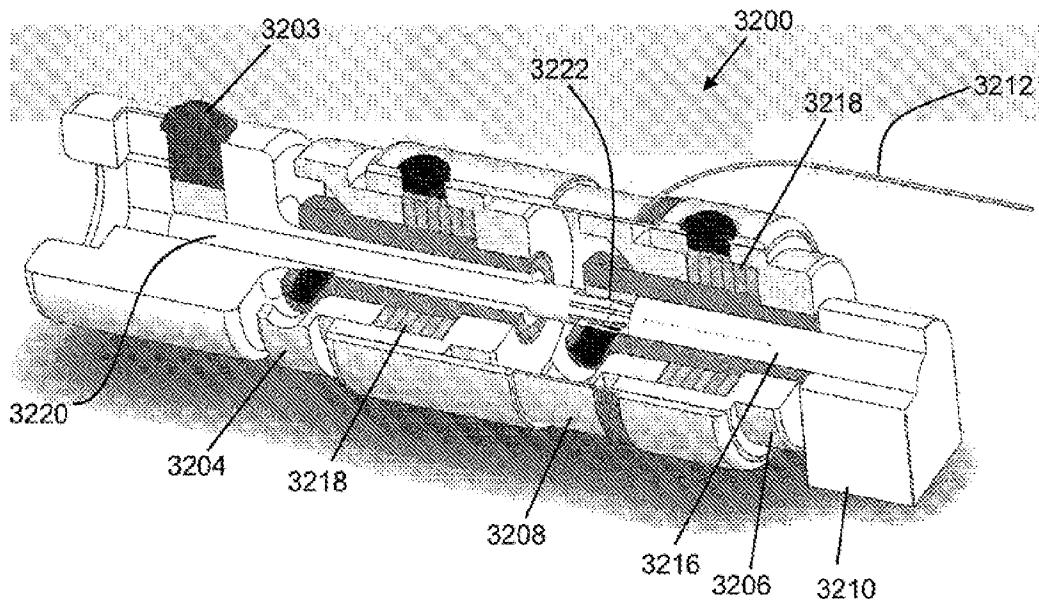

FIG. 32C

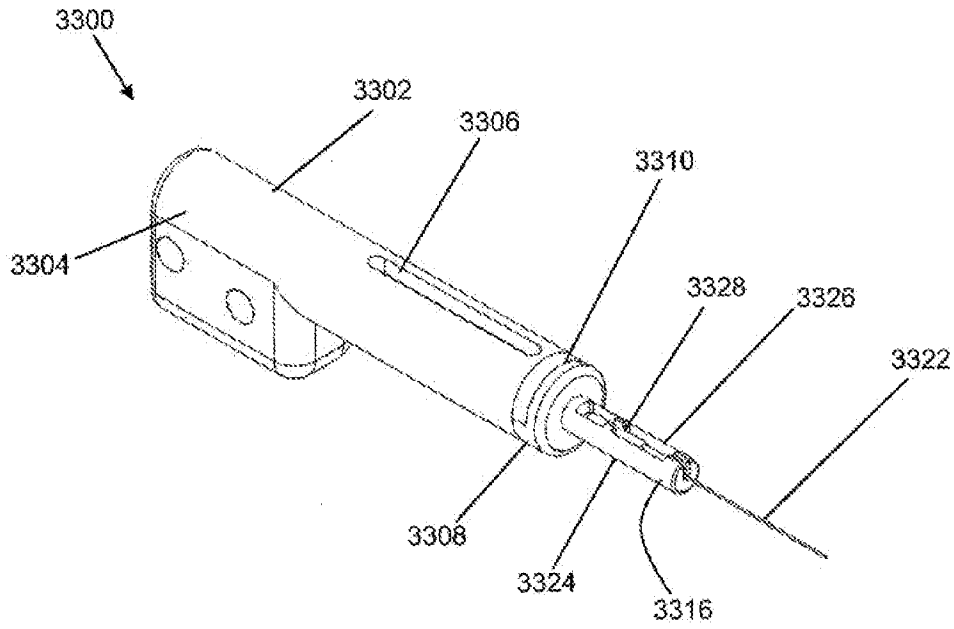

FIG. 33A

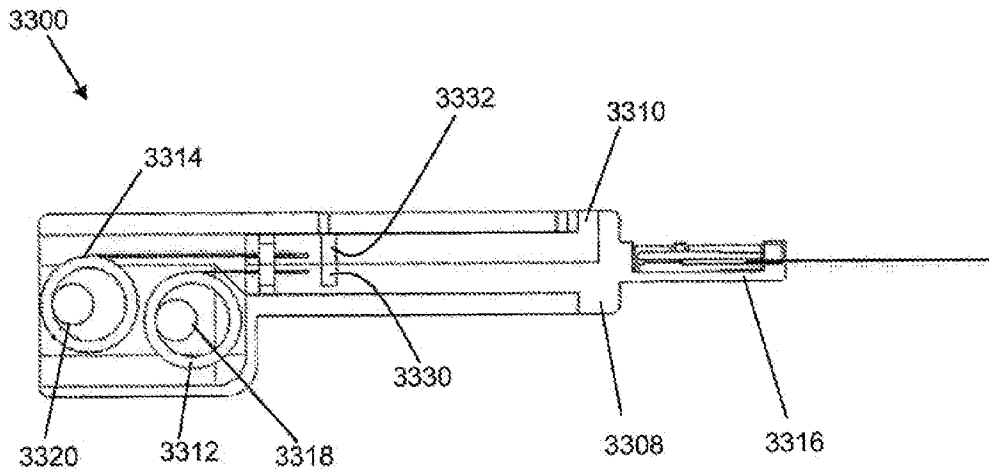

FIG. 33B

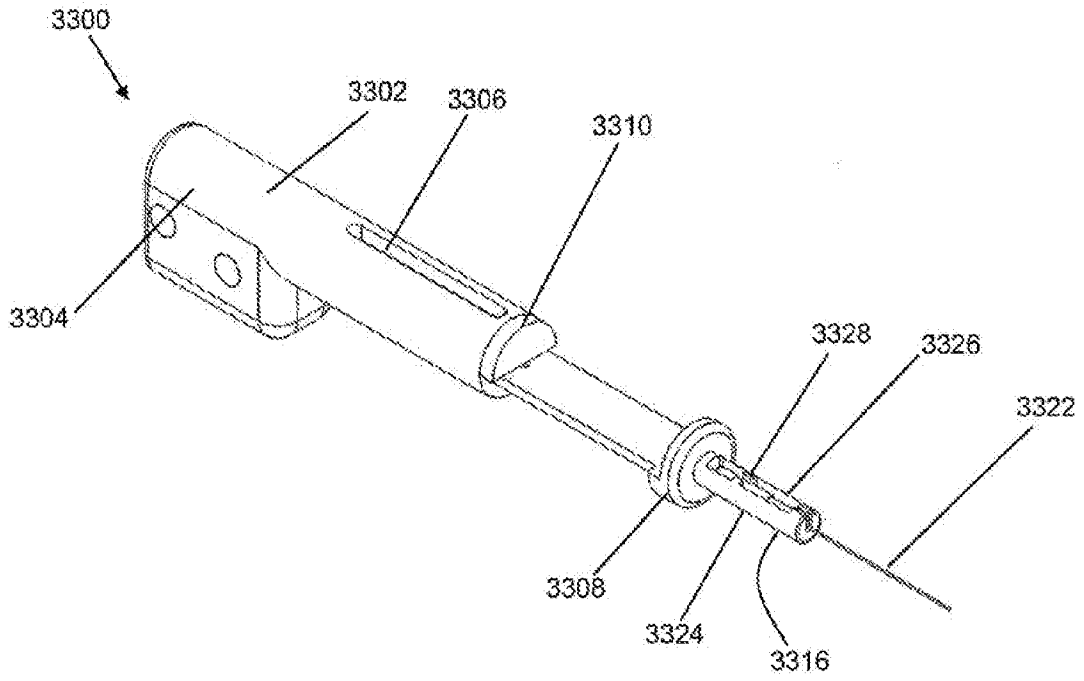

FIG. 33C

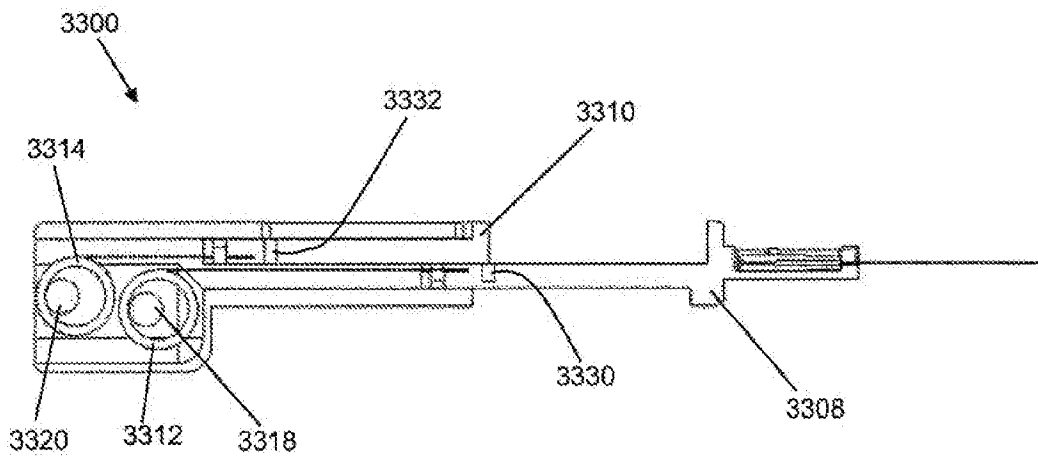

FIG. 33D

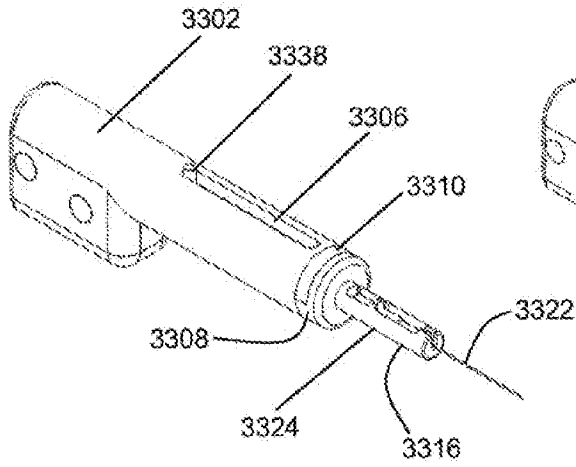

FIG. 33E

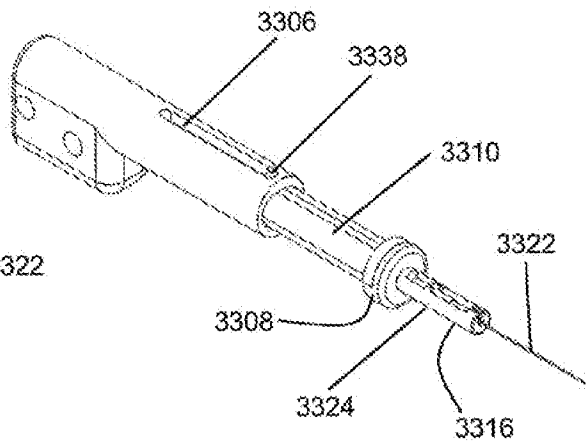

FIG. 33F

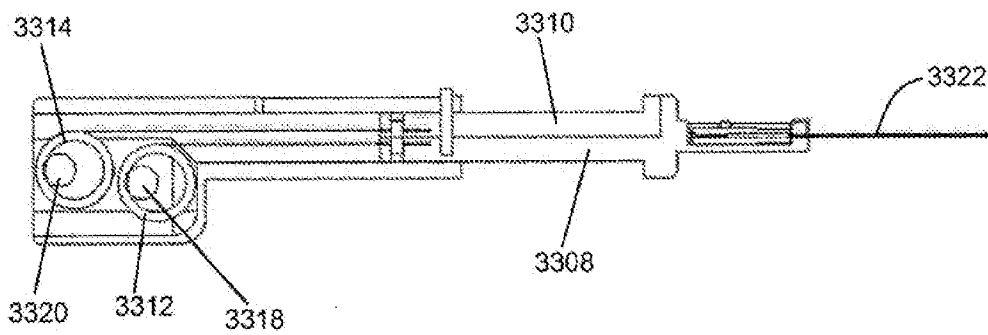

FIG. 33G

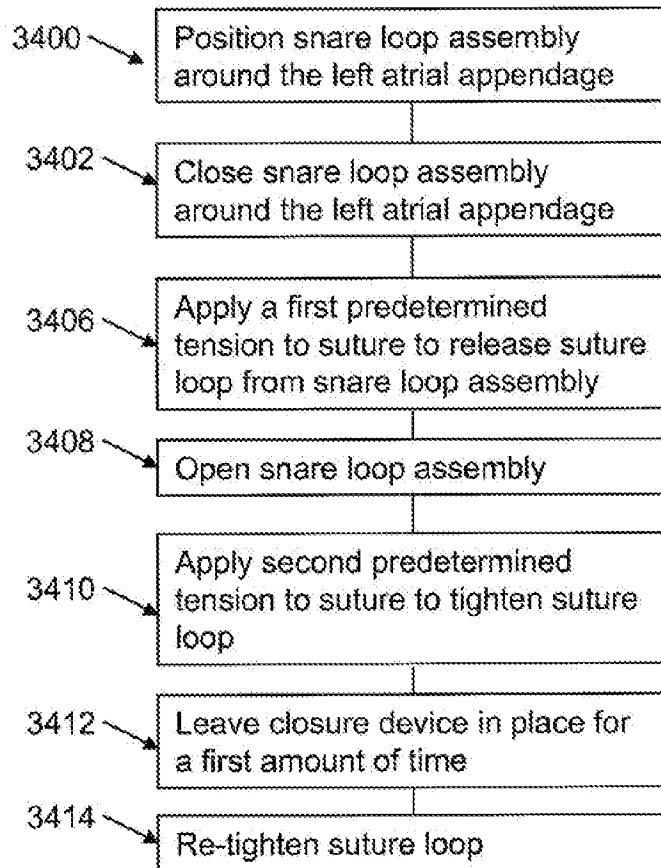

FIG. 34

34/36

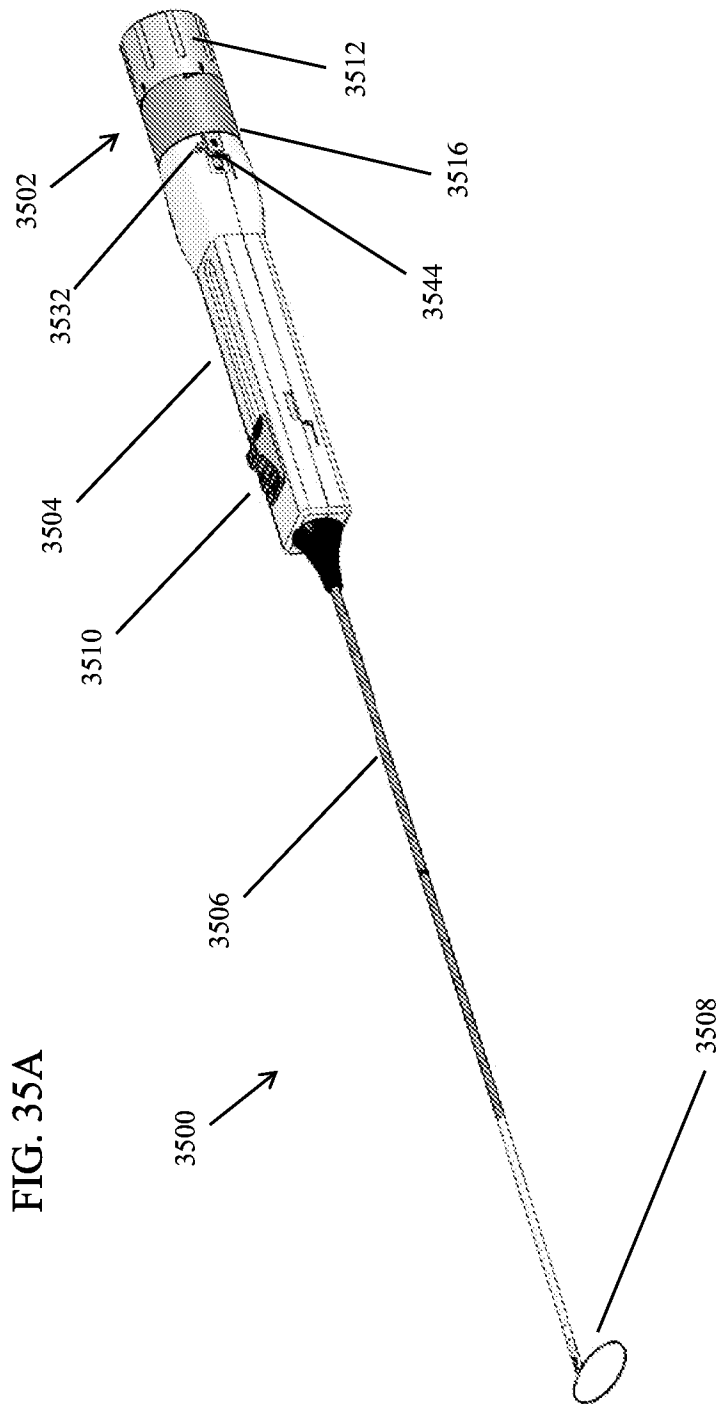
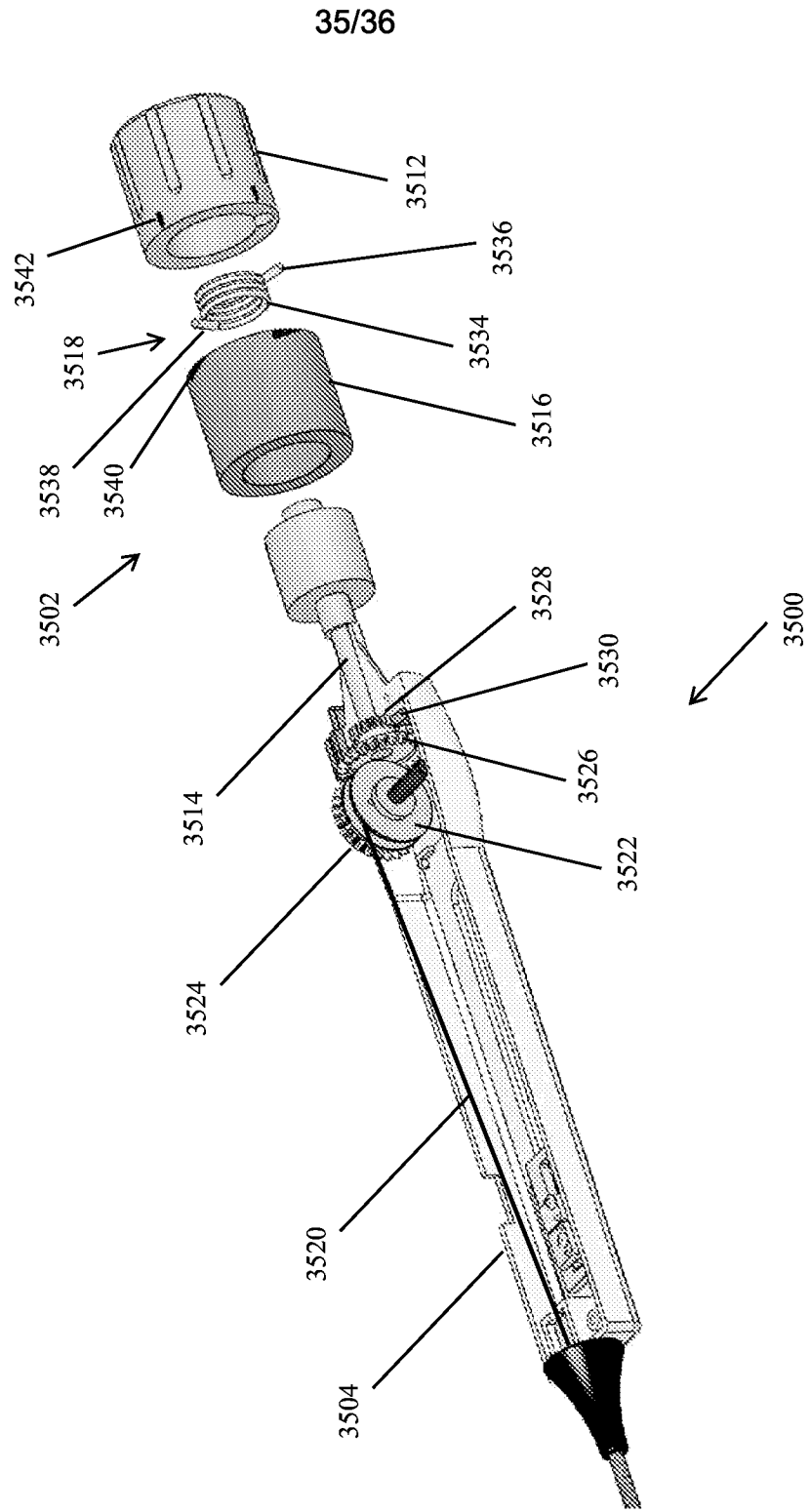
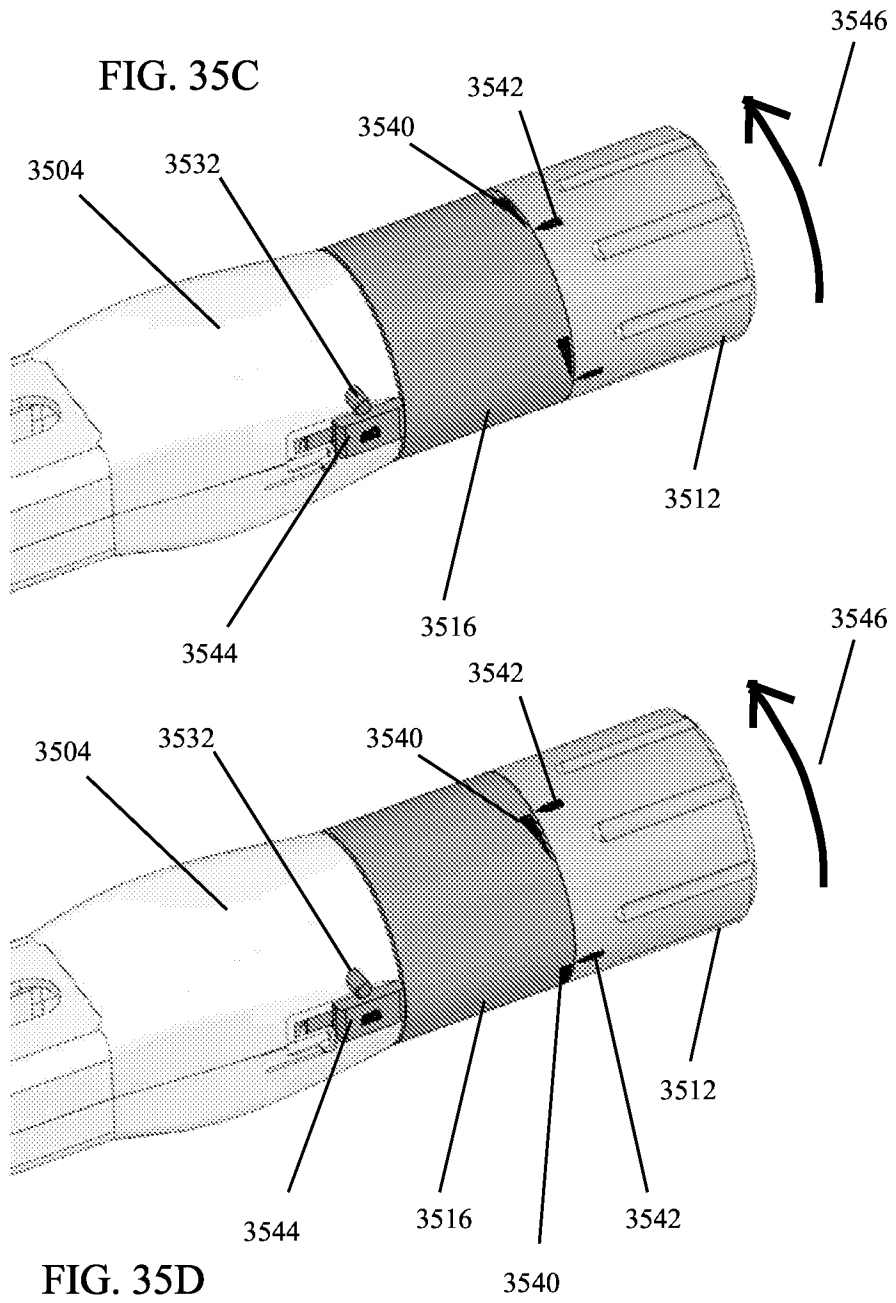

FIG. 35A

FIG. 35B





INTERNATIONAL SEARCH REPORT

International application No.

PCT/US 12/41285

A. CLASSIFICATION OF SUBJECT MATTER

IPC(8) - A61B 17/12 (2012.01)
USPC - 606/144

According to International Patent Classification (IPC) or to both national classification and IPC

B. FIELDS SEARCHED

Minimum documentation searched (classification system followed by classification symbols)
IPC(8) - A61B 17/12 (2012.01)
USPC - 606/144

Documentation searched other than minimum documentation to the extent that such documents are included in the fields searched
IPC(8) - A61B 17/12 (2012.01)
USPC - 606/139, 144, 146, 148, 151, 157, 158

Electronic data base consulted during the international search (name of data base and, where practicable, search terms used)
PubWEST (PGPB, USPT, EPAB, JPAB); Google (Patents, Scholar, Web)
Search Terms: Snare, loop, tissue, suture, tension, pull, release, separate, first, second, open, pressure, force, tighten, re-tighten, second, device, couple, attach, secure, force, gauge, indicator, digital, display, knob, spool, clutch, housing, spring, extension, fob, left,

C. DOCUMENTS CONSIDERED TO BE RELEVANT

Category*	Citation of document, with indication, where appropriate, of the relevant passages	Relevant to claim No.
X ----- Y	US 2011/0087247 A1 (FUNG et al.) 14 April 2011 (14.04.2011) Fig. 1, 3A-3B, 7-11; Para [0037]-[0039], [0041], [0081], [0085]-[0086], [0095]-[0097], [0106], [0111]-[0112], [0119]-[0122], [0124], [0126], [0136]	1-15 ----- 16-32
Y	US 2010/0191253 A1 (OOSTMAN et al.) 29 July 2010 (29.07.2010) Para [0045]-[0046]	16, 19-21, 29-32
Y	US 2004/0068267 A1 (HARVIE et al.) 08 April 2004 (08.04.2004) Fig. 3B; Para [0089]-[0092]	17, 22-25
Y	US 2010/0331820 A1 (GIUSEPPE et al.) 30 December 2010 (30.12.2010) Fig.2A; Para [0019]-[0027]	18, 26-28
A	US 5,398,911 A (HOLSTER) 21 March 1995 (21.03.1995) Fig. 1-2; col 3, ln 4-18, col 4, ln 56 to col 5, ln 11	17, 22-25
A	US 2011/0060350 A1 (POWERS et al.) 10 March 2011 (10.03.2011) Fig. 3, 5-9; Para [0034]-[0036], [0040]-[0042]	27-28

Further documents are listed in the continuation of Box C.

* Special categories of cited documents:

- "A" document defining the general state of the art which is not considered to be of particular relevance
- "E" earlier application or patent but published on or after the international filing date
- "L" document which may throw doubts on priority claim(s) or which is cited to establish the publication date of another citation or other special reason (as specified)
- "O" document referring to an oral disclosure, use, exhibition or other means
- "P" document published prior to the international filing date but later than the priority date claimed

- "T" later document published after the international filing date or priority date and not in conflict with the application but cited to understand the principle or theory underlying the invention
- "X" document of particular relevance; the claimed invention cannot be considered novel or cannot be considered to involve an inventive step when the document is taken alone
- "Y" document of particular relevance; the claimed invention cannot be considered to involve an inventive step when the document is combined with one or more other such documents, such combination being obvious to a person skilled in the art
- "&" document member of the same patent family

Date of the actual completion of the international search
17 August 2012 (17.08.2012)

Date of mailing of the international search report
14 SEP 2012.

Name and mailing address of the ISA/US
Mail Stop PCT, Attn: ISA/US, Commissioner for Patents
P.O. Box 1450, Alexandria, Virginia 22313-1450
Facsimile No. 571-273-3201

Authorized officer:
Lee W. Young
PCT Helpdesk: 571-272-4300
PCT OSP: 571-272-7774