

1,027,590.

Patented May 28, 1912.

Fig. 1.

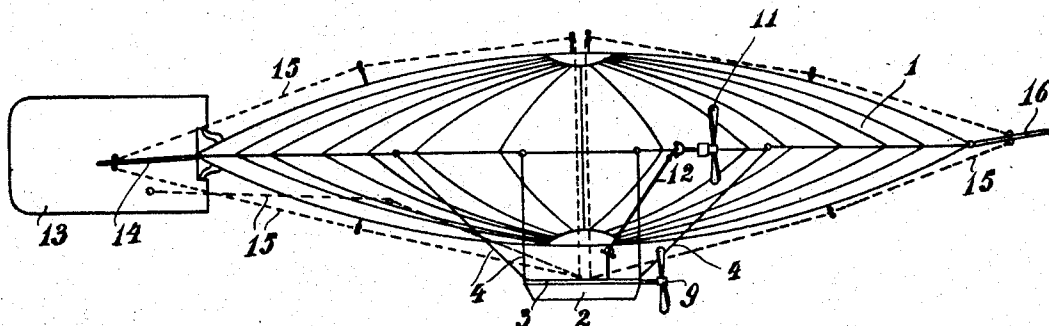
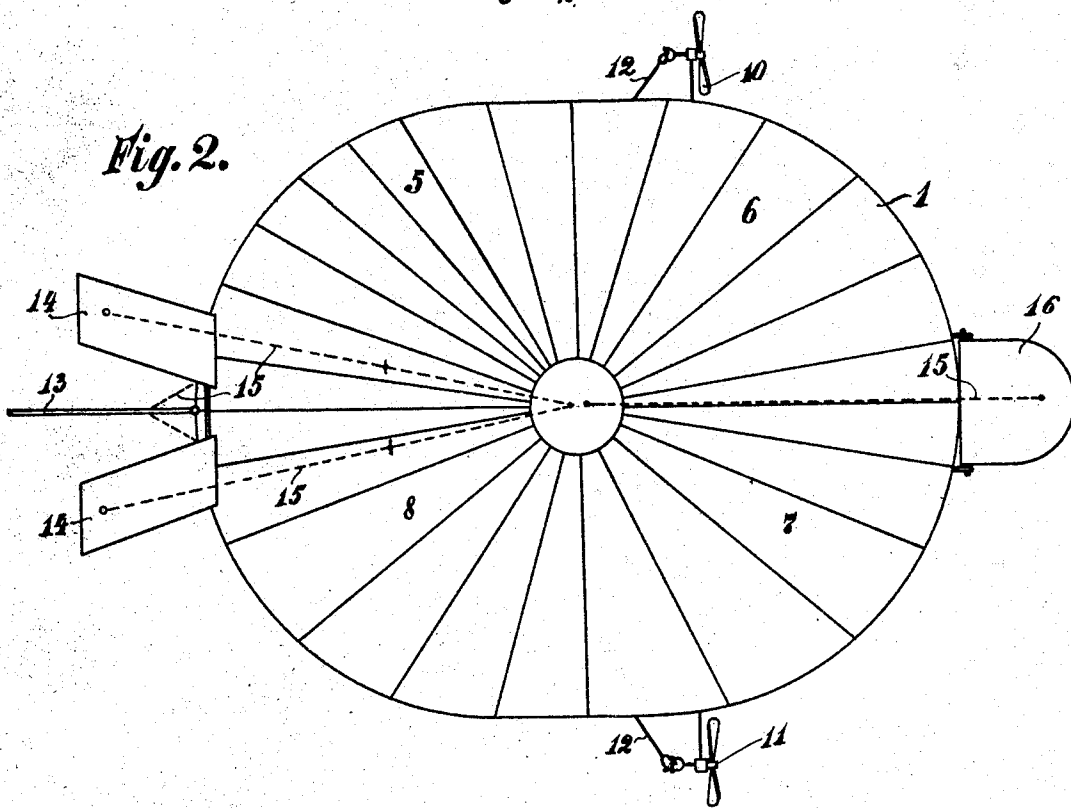

Fig. 2.



Witnesses  
 E. Schallinger  
 C. Rehm

Inventor  
 Ernst Bucher  
 by J. Singer  
 Atty

# UNITED STATES PATENT OFFICE.

ERNST BUCHER, OF HEIDELBERG, GERMANY.

DIRIGIBLE AIRSHIP.

1,027,590.

Specification of Letters Patent.

Patented May 28, 1912.

Application filed June 3, 1910. Serial No. 564,810.

*To all whom it may concern:*

Be it known that I, ERNST BUCHER, optician, a subject of the King of Wurttemberg, residing at 1 Neue Schloss strasse, Heidelberg, Grand Dukedom of Baden, Germany, have invented a new and useful Improved Dirigible Airship, of which the following is a specification.

This invention relates to a dirigible airship, especially suitable for sporting purposes, the novelty of which consists in the combination of the peculiarities of airships and kites due to its special lens-shape, and therefore combines the advantages obtaining in both these devices. These advantages consist firstly in the lens-shape of the balloon body so that it has a great supporting capacity, and therefore acts also as an aeroplane during fast travel. Further the lens-shape of the balloon body permits it to cut the air in all directions whereby side steering is considerably facilitated; side currents of air can be easily overcome, the vehicle has the capacity of turning around on its own axis and on account of its round form it requires the smallest space for landing as compared with any other dirigible airship.

Another advantage connected with this new airship is the arrangement of additional screws at the side of the balloon body, as well as the screw on the car, such additional screws being adapted to be worked in either a horizontal or vertical position to permit, respectively the horizontal propulsion of the vehicle, or the steering the latter up or down.

In order that this invention may be the better understood, I will now proceed to describe the same with reference to the accompanying drawing and show by way of example diagrammatically how this new airship may be constructed.

Figure 1 is a side view of the airship and Fig. 2 is a plan view of the same.

As shown in the drawing, the rigid skeleton 1 of the airship has the form of a lens with flattened or cut-off sides. From this rigid frame is suspended another frame 3 constructed according to the shape of the car and to which said car is attached. The frame 3 is connected by rigid stays 4 to the framework of the airship so that the car is only a very small distance from the body of the balloon. The rigid frame 1 is provided in its interior with four flat gas chambers

5, 6, 7 and 8 which keep the load of the vehicle afloat, so that the screws have only to effect the propulsion, or respectively the raising and lowering of the airship. At the front of the frame 2 is provided a horizontal screw 9 which in known manner serves for the propulsion of the airship. On each of the flattened sides of the airship there is arranged another screw 10, 11 respectively, in such a manner that the same may be placed horizontally as well as vertically. These screws are driven by flexible axles, cardan couplings or the like 12 and may be used for propulsion of the vehicle as also for raising, lowering and side steering it. Otherwise the steering of the balloon is effected in known manner by vertical and horizontal planes 13 and 14 respectively, provided at the rear end, which are operated from the car through wires 15. In order to assist the rear elevating rudder, the horizontal plane 16 is arranged at the front end of the balloon and is also operated by wires.

The charge of the balloon is calculated so that its lifting force equals the weight of the vehicle, or slightly exceeds the same to provide for subsequent losses of gas. If it is now desired that the balloon should rise, the side screws are first placed vertically so that they act as lifting screws and raise the car in a more or less rising path according to the rate of revolution of the car screw and the adjustment of the elevating rudders. When the desired height has been attained, the side screws are disengaged and after corresponding adjustment of the elevating rudders they are put into a horizontal plane in which they assist in horizontal propulsion. For side steering which is easily effected the usual vertical planes at the rear end are generally used, but this operation may be supported by the single running of one of the side screws.

It will be obvious that airships according to the present invention are not designed for the carrying of great loads, but are especially useful for sporting purposes and for short journeys, for which purpose it may suitably be constructed to carry about four persons.

I claim:

An airship comprising in combination, a lens-shaped balloon plane terminating in a sharp outer edge extending completely

around the balloon plane, propulsion devices  
alined with and at the side edges of said  
plane, a vertically movable steering plane  
on a line with the front edge of said balloon  
5 plane, a horizontally movable steering rudder  
at the rear of said balloon plane, and  
vertically movable steering planes at the

rear of and on a line with the edge of said  
balloon plane, said planes being on opposite  
sides of said rear steering plane.

ERNST BUCHER.

Witnesses:

ERNEST L. IVES,  
W. W. J. CUNROT.