

Jan. 8, 1929.

1,698,703

H. F. GAU

HEATING PAD

Filed Dec. 13, 1926

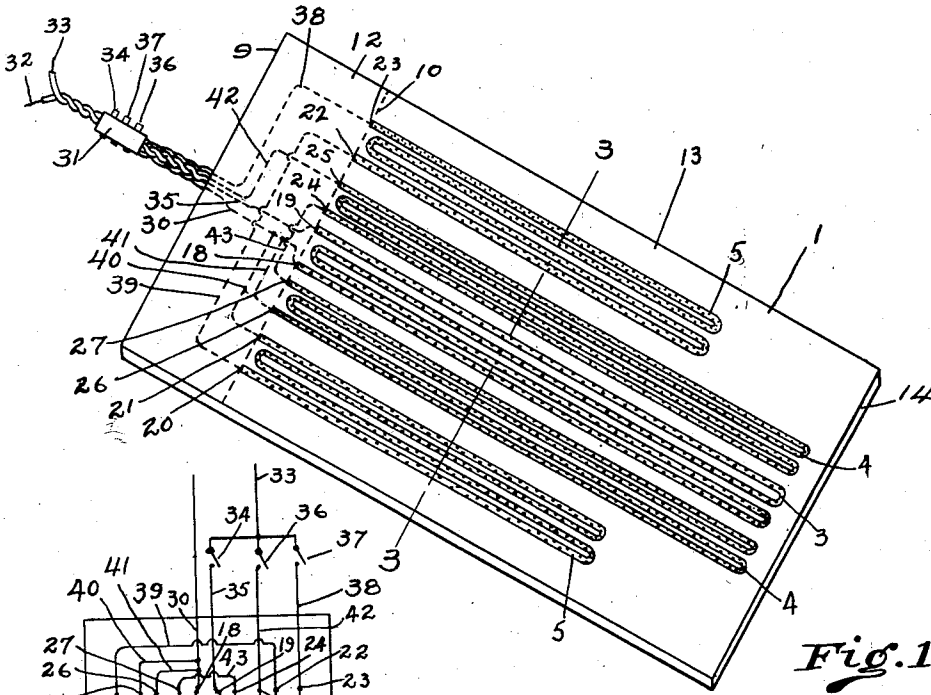

Fig. 1.

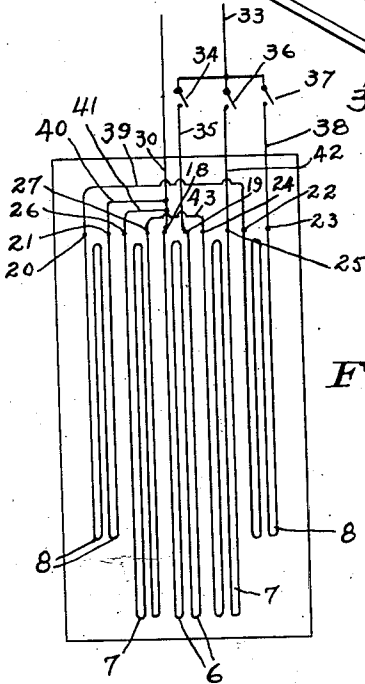

Fig. 2.

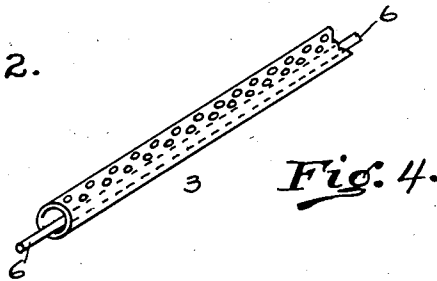

Fig. 4.

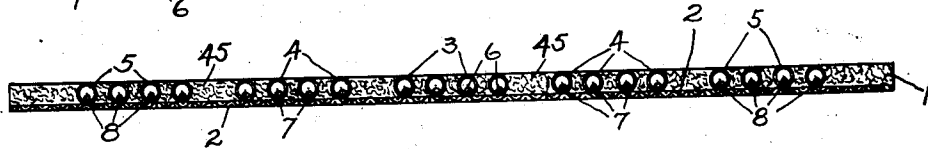

Fig. 3.

Inventor
Henry F. Gau
By John W. Grehli
Attorney

UNITED STATES PATENT OFFICE.

HENRY F. GAU, OF CINCINNATI, OHIO.

HEATING PAD.

Application filed December 13, 1926. Serial No. 154,472.

This invention relates to heating pads, particularly such heating pads as are used for heating beds of the sick or those deficient in natural heat, or for general use.

5 The invention presents an arrangement of parts which overcomes many disadvantages of other heating pads and adds greatly to the efficiency of the heating combination as well as increasing the comfort of the user.

10 It is my purpose in this invention to provide direct heat to the body, there being no covering or coating directly on the heating element itself, the heating element sending its heat rays directly to the body supplying thereby a more energizing heat.

15 Means are also provided to direct the heat upward and to prevent downward radiation, and thereby use to the greatest extent, the heat energy produced. Means are also provided to supply this heat in a particular zone of the bed as may be found most desirable as well as necessary and efficient.

20 Means are also provided whereby the various zones of heat may be made effective, either singly or together, the zone of heat being under control of the user in such a manner that either of the several zones may be made effective, or all may be made effective, and any single zone or all may be discontinued or cut off, as found necessary.

30 In the drawing:

Fig. 1, is a perspective view of the warming pad showing three heating zones,

35 Fig. 2, is a diagrammatic view of the wiring arrangement,

Fig. 3, is a section on line 3-3 of Fig. 1, and

40 Fig. 4, is a perspective view of a portion of one of the heating tubes and the heating element therein.

The pad 1 is made up of a base 2 upon which are mounted, in any suitable manner, the several sets of heating tubes marked 3, 4, and 5, and within which are the heating elements or wires 6, 7 and 8.

45 The pad may be divided into two parts, the part 12 which extends from the end marked 9 to the dotted line 10 and is covered by the pillow, and the part 13 which extends from the line 10 to the end marked 14, upon which the body rests.

50 The base 2 may be of any suitable heat-insulating material, such as asbestos cloth, or kindred material, and upon this base 2, and between the line 10 and the end 14, I provide the perforated heating tubes 6, 7, and 8,

secured to the base 2 in any suitable manner, and arranged into groups for the purpose of distributing the heat properly. The heating tubes 3, 4, and 5 are made of bakelite or 60 kindred non-conducting material, being sufficiently rigid to prevent collapsing under the weight of the body and at the same time flexible enough to yield somewhat to conform to the body, and inside these tubes I provide 65 heating elements 6, 7, and 8 usually in the form of wire.

The central group of these tubes marked 3 extends from the line 10 to a point near the foot and consists of a plurality of perforated 70 tubes 3, Fig. 4, through which a heating element 6 passes, being continuous from the point 18 through the several rows of tubes to the point 19.

75 The two side groups 5, 5, extend from the line 10 about two-thirds of the distance to the end 14, and each consists of a plurality of perforated tubes through which pass the heating elements 8, 8, being continuous 80 through the several tubes from point 20 to point 21, and from point 22 to point 23, these side groups 5, 5, being adapted to act together.

85 On each side of the group 3 and between this group and the side groups 5, 5, I place intermediate groups 4, 4, extending from line 10 to a point near the foot 14, these groups like groups 3 and 5 are made up of a series of tubes perforated on their upper side and having heating elements 7, 7, which pass 90 entirely through the tubes being continuous through one section 4, from point 24 to point 25 and through the other section 4, from point 26 to point 27.

95 Electric current from a suitable source is supplied through a multiple switch 31 from the wires 32 and 33, and a lead wire 30 from the switch 31 connects the wire 32 to the heating element 6 at the point 18, a lead wire 35 connects the switch 34 of the multiple switch 100 31, to the heating elements 6 at the point 19, the switch 34 being adapted to form electrical connection between the lead wire 35 and the supply wire 33 thereby closing the circuit of the heating element 6 to make it operative. 105

A lead wire 38 from the switch 37 is connected to one part of the heating element 8 at 23, the cross connecting wire 39 connecting this part at 22 is also connected to the other part of the heating element 8 at 20, and a lead 110 wire 40 connects the free end of the heating element 8 at 21 to the lead wire 30, and there-

by to the supply wire 32, the switch 37 being adapted to close the circuit through the heating elements 8, to thereby render them operative.

5 A lead wire 42 connects the switch 36 with one section of the heating element 7 at point 25, and a cross connecting wire 43 connected to this part of the heating element 7 at point 24, is connected to the other part of the heating element 7 at 27, the free end of the heating element 7 being connected at 26 to a lead wire 41, which in turn is connected to lead wire 30, and thereby to supply wire 32.

10 The switch 36 is adapted to connect the lead wire 42 with the supply wire 33 thereby closing the electrical circuit through heating elements 7 and rendering them operative.

15 The lead wires 30, 35, 38, 42, 40 and 41, being properly insulated are partially embedded in that portion of the pad between the line 10 and the end 9, while the lead wires 40 and 41, together with the cross connecting wires 39 and 43, being properly insulated are entirely embedded in that portion of the pad, 20 between the line 10 and the end 9.

25 Between the tubes of the several sections, and on that portion of the pad which is not traversed by the tubes, I provide a filler 45 of asbestos, wool, felt, or equivalent material which is secured to the base 2 in any suitable 30 manner.

In operation I place the pad on a bed, with the end 9 to the head and the end 14 to the foot thereof, the pillow occupying the space 35 between line 10 and end 9, the sleeper resting upon the pad 1, and one or more of the switches 34, 36, 37 closed, whereby sufficient heat will be supplied through the tubes to provide comfort and protect the sleeper 40 against being chilled, making very light cover sufficient and thereby adding greatly to the rest of the sleeper.

45 It will be understood that I have explained one system of tubes, wiring and switches, and any other system may be used, as there are many wiring and switch systems known in the art. The groups of tubing may be dis-

tributed on the pad in any form and location, or one unit system may be used by me; and various areas thereof be heated as may be 50 needed for the specific purpose for which the pad is used.

I claim as part of my invention, any modifications or changes which can be made, in my heating pad, which will fall within the 55 scope of this specification and claims.

What I claim as new and my invention and desire to secure by Letters Patent is:

1. A heating pad comprising a base, a tube of insulating material resting on the base, 60 capable of flexing longitudinally, and having sufficient rigidity to prevent collapsing of the same, and an electric heating element arranged in the tube, the tube being perforated along one side to permit the radiation of heat 65 through the wall of the same, the remainder of the tube being imperforate.

2. A heating pad comprising a flexible sheet of insulating material forming a base, a 70 substantially rigid tube of insulating material secured to the base and extending back and forth over the base to provide a tortuous chamber, said tube having unobstructed perforations on its upper side, and the remainder 75 of the tube being imperforate, a layer of insulating material arranged on the base and of a thickness equal to the diameter of the tube, said filling material being arranged on opposite sides of the tube, and an electric heating element arranged in said chamber. 80

3. A heating pad comprising a sheet-like structure, a number of tubes of insulating material arranged on the upper side of said structure and each extending back and forth 85 over a portion of the structure, said tubes being perforated, a separate electric heating element for each of said tubes, and means for furnishing current to any one of said heating elements independently of the other elements.

In testimony whereof, I affix my signature 90 at Cincinnati, Ohio, this 30th day of November, 1926.

HENRY F. GAU.