



US007559805B1

(12) **United States Patent**
Yi et al.

(10) **Patent No.:** **US 7,559,805 B1**
(45) **Date of Patent:** **Jul. 14, 2009**

(54) **ELECTRICAL CONNECTOR WITH POWER CONTACTS**

(75) Inventors: **Chong Yi**, Mechanicsburg, PA (US);
Kuan-Yu Chen, Harrisburg, PA (US);
Pei Tsao, Fullerton, CA (US)

(73) Assignee: **Hon Hai Precision Ind. Co., Ltd.**,
Taipei Hsien (TW)

(*) Notice: Subject to any disclaimer, the term of this patent is extended or adjusted under 35 U.S.C. 154(b) by 0 days.

(21) Appl. No.: **12/215,088**

(22) Filed: **Jun. 24, 2008**

(51) **Int. Cl.**
H01R 24/00 (2006.01)

(52) **U.S. Cl.** **439/660**

(58) **Field of Classification Search** 439/660,
439/607, 541.5, 680

See application file for complete search history.

(56) **References Cited**

U.S. PATENT DOCUMENTS

- 6,062,892 A * 5/2000 Meng et al. 439/357
- 6,334,793 B1 1/2002 Amoni et al.
- 7,354,282 B2 * 4/2008 Margulis et al. 439/79
- 2006/0014431 A1 * 1/2006 Shuey et al. 439/607
- 2007/0049115 A1 3/2007 Igarashi et al.

* cited by examiner

Primary Examiner—Phuong K Dinh

(74) *Attorney, Agent, or Firm*—Wei Te Chung

(57) **ABSTRACT**

An electrical connector includes an electrical receptacle and an electrical plug for mating with the electrical receptacle. The electrical receptacle includes a first port, a second port communicating with the first port. The second port can accommodate a standard B-type USB 2.0 plug. The first and the second ports can be combined to receive the electrical plug for high-speed signal transmission. The second port comprises a plurality of power contacts for voltage transmission.

11 Claims, 16 Drawing Sheets

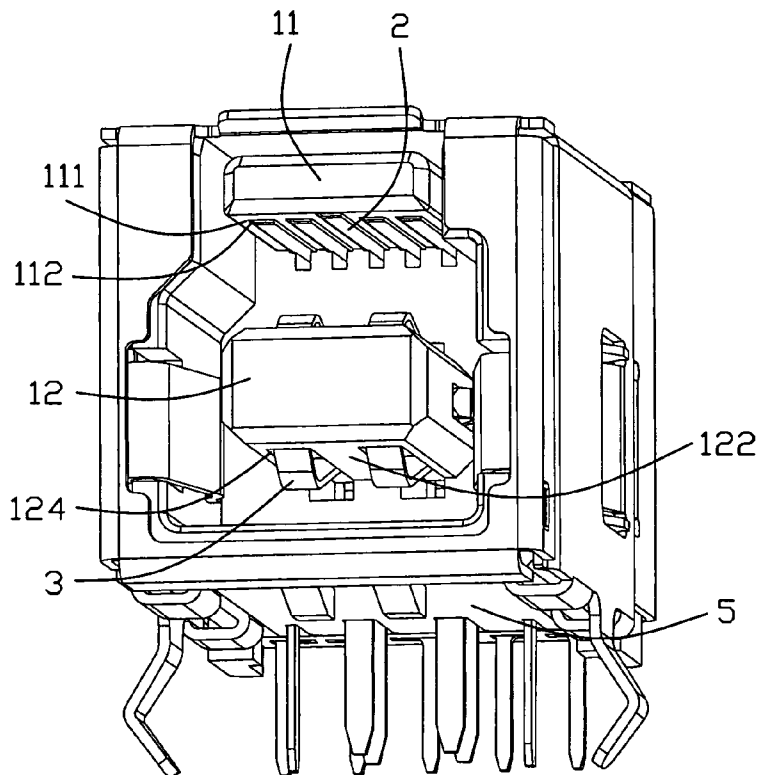

100

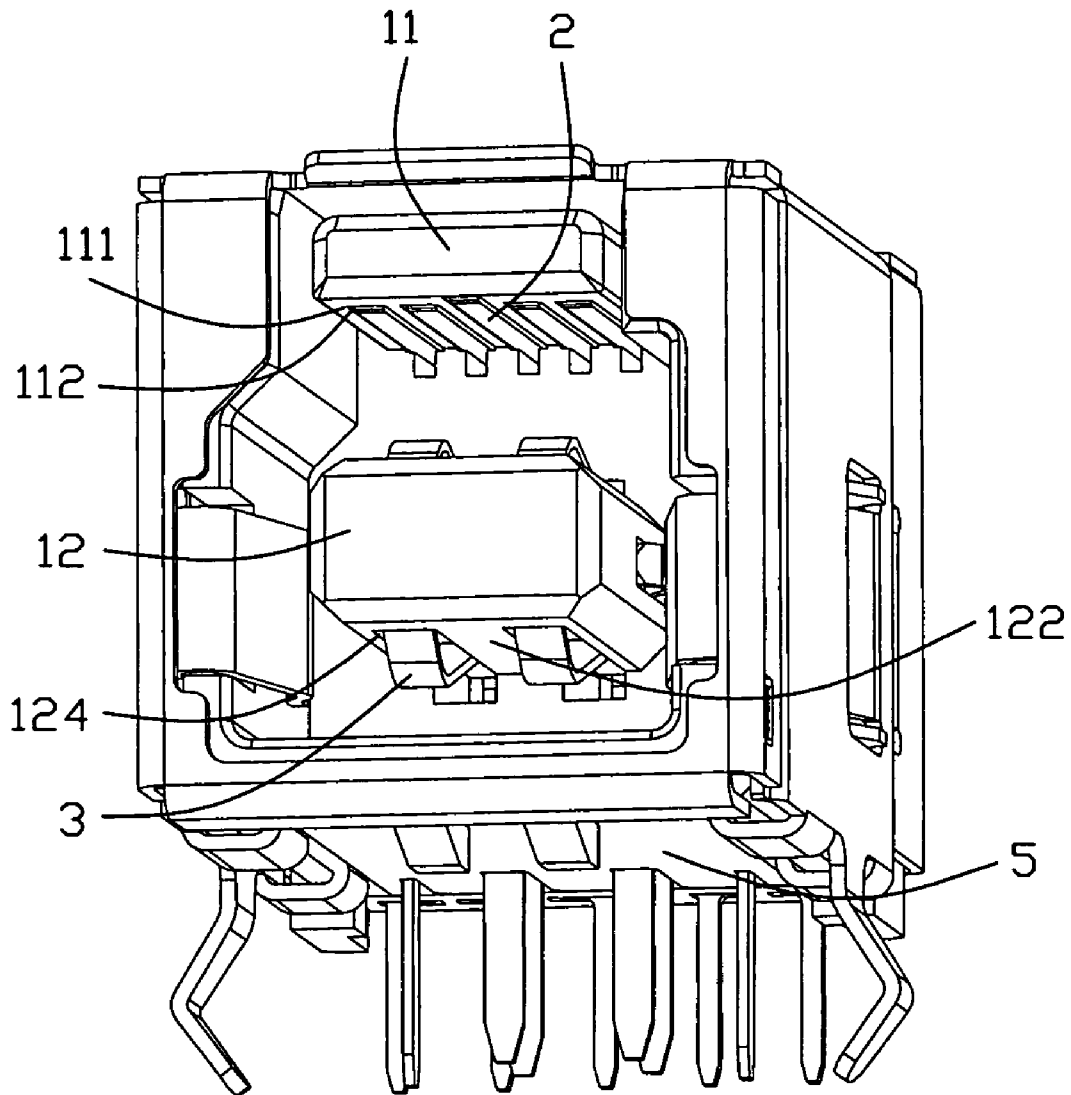

FIG. 1

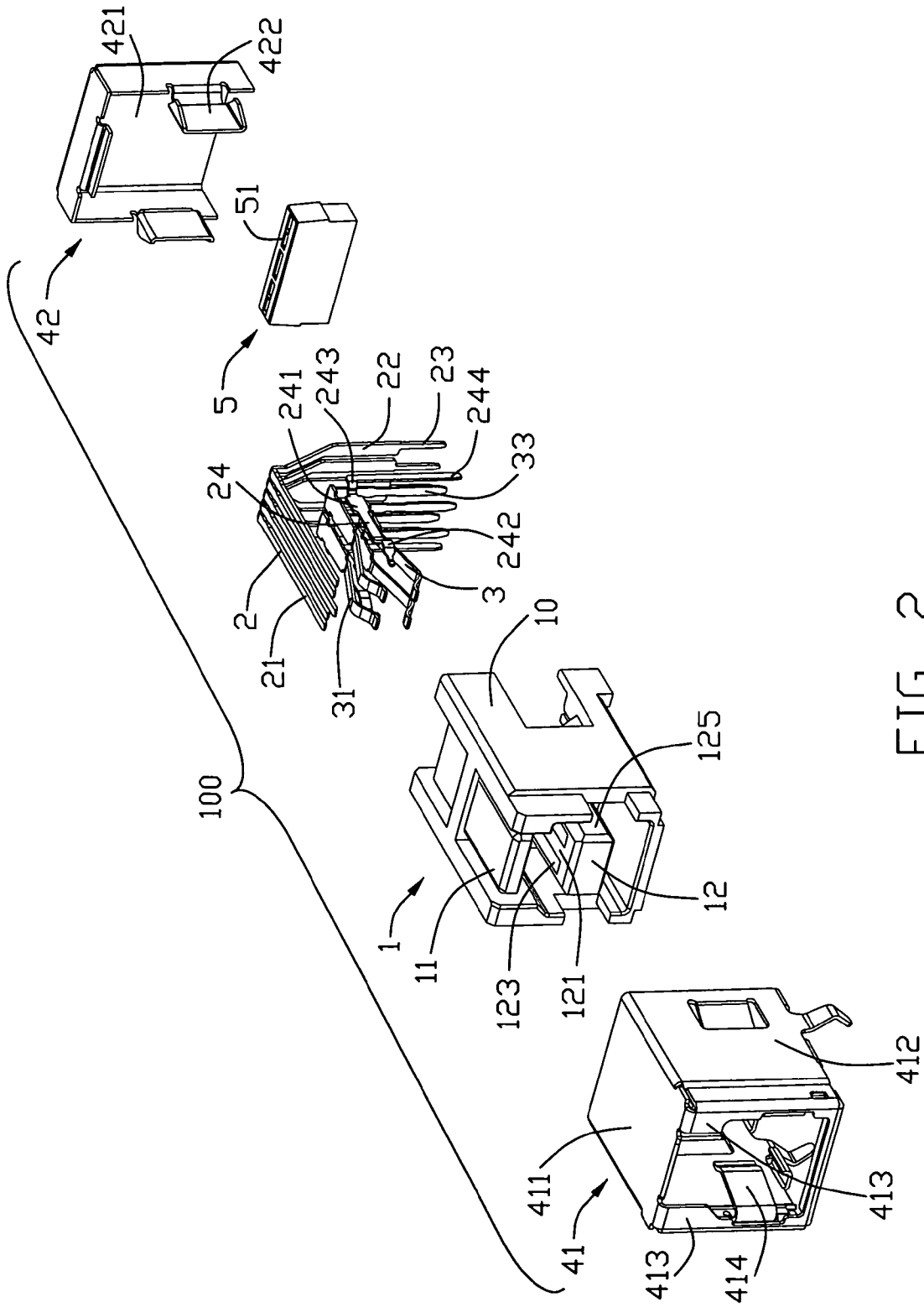

FIG. 2

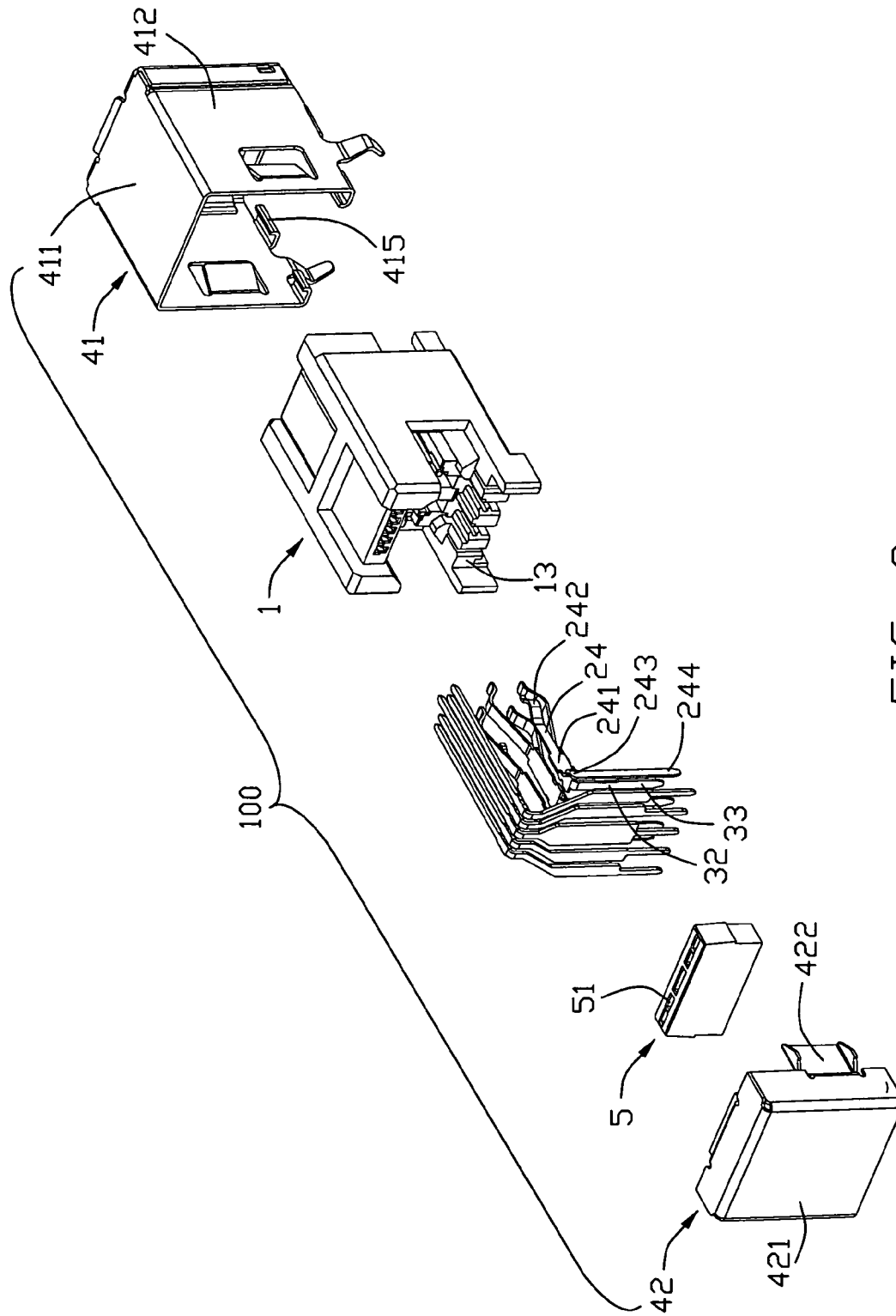

FIG. 3

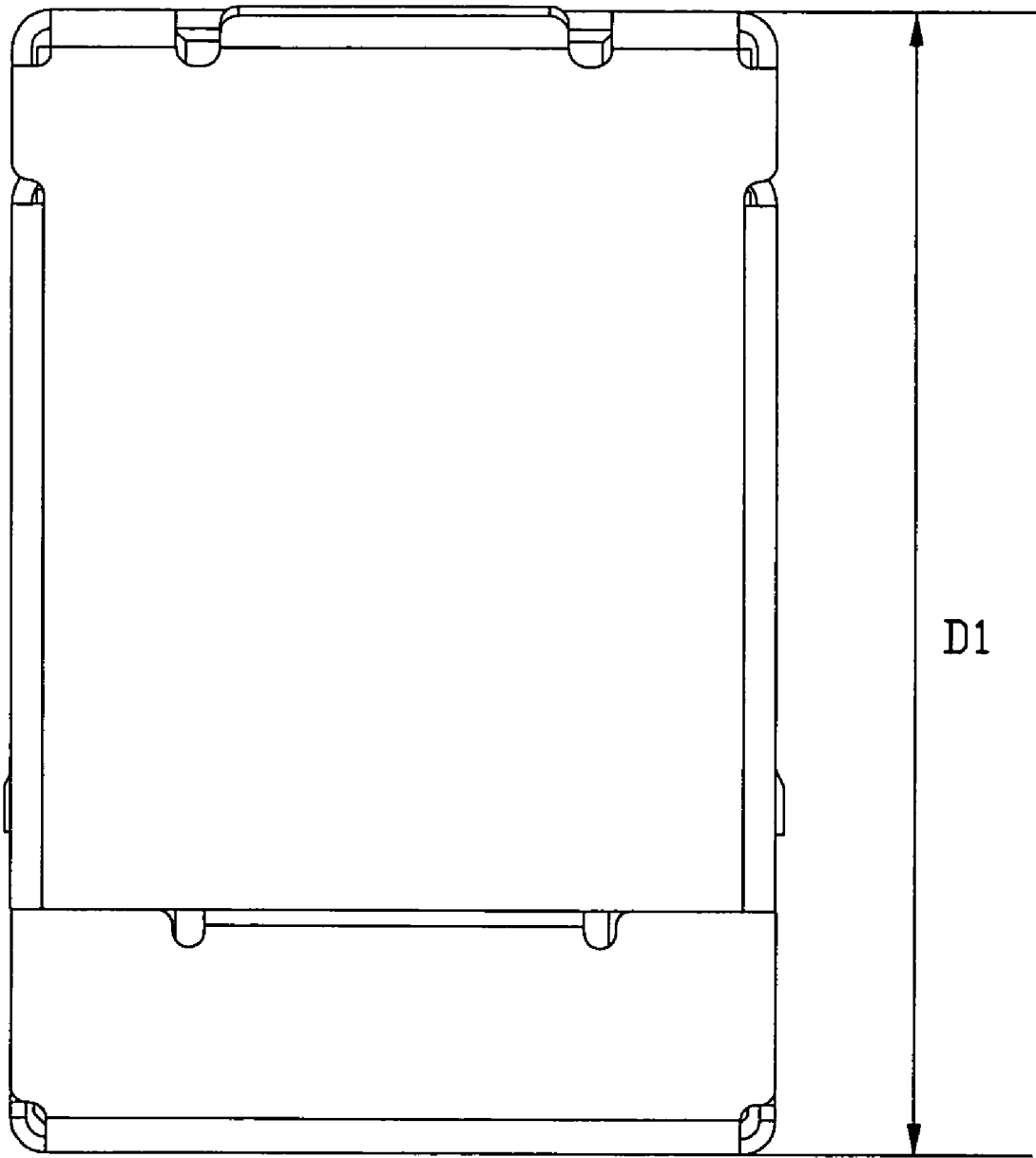

FIG. 5

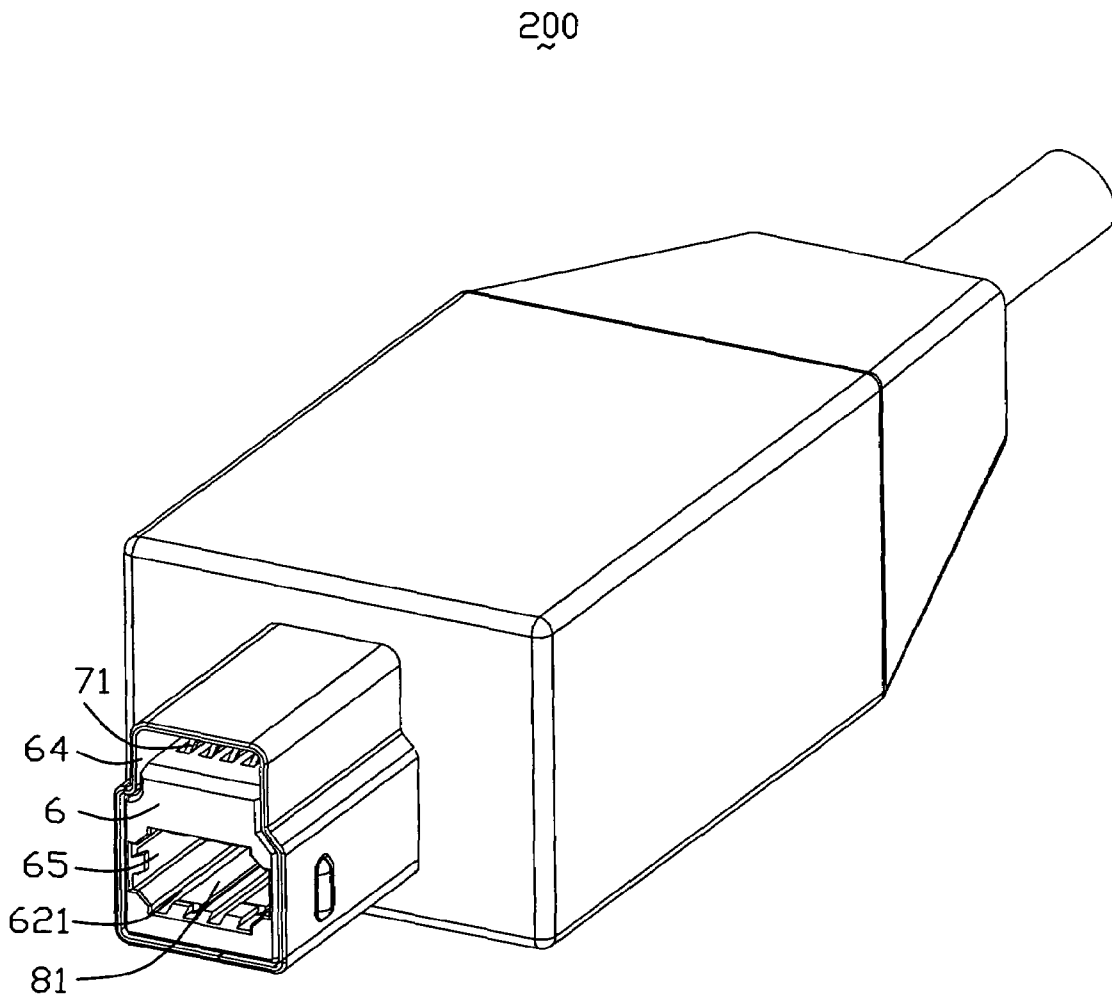

FIG. 6

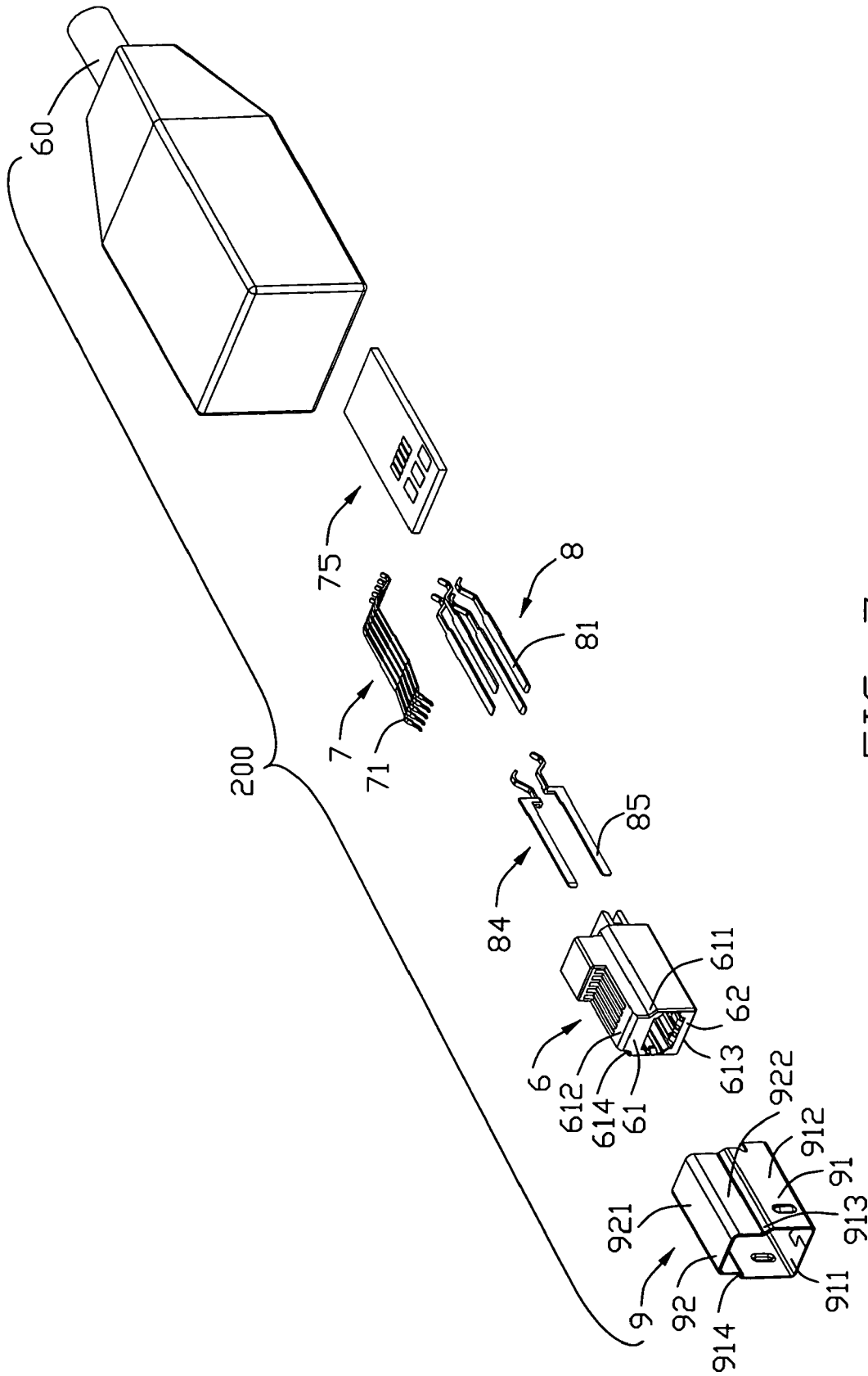

FIG. 7

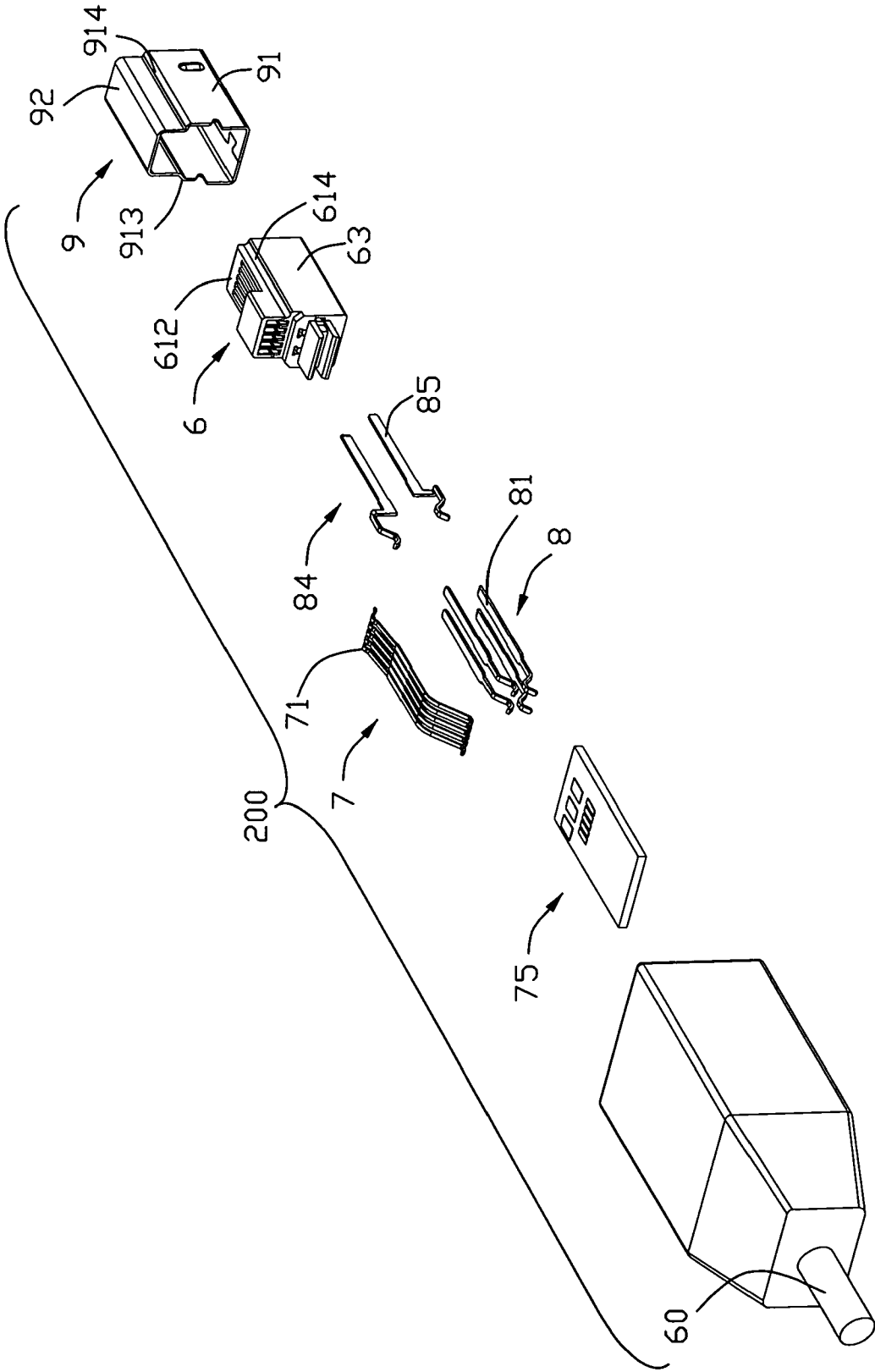

FIG. 8

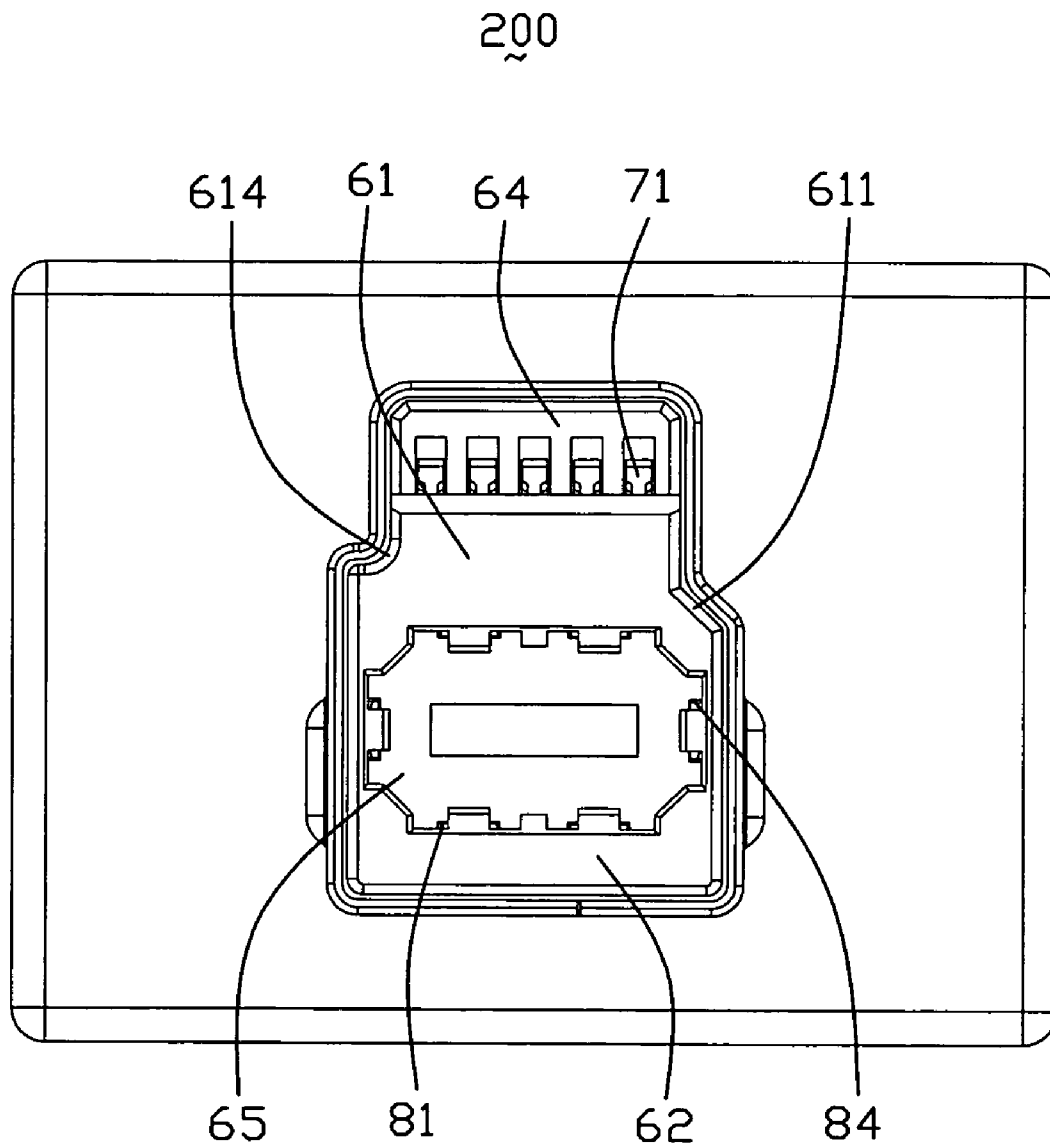

FIG. 9

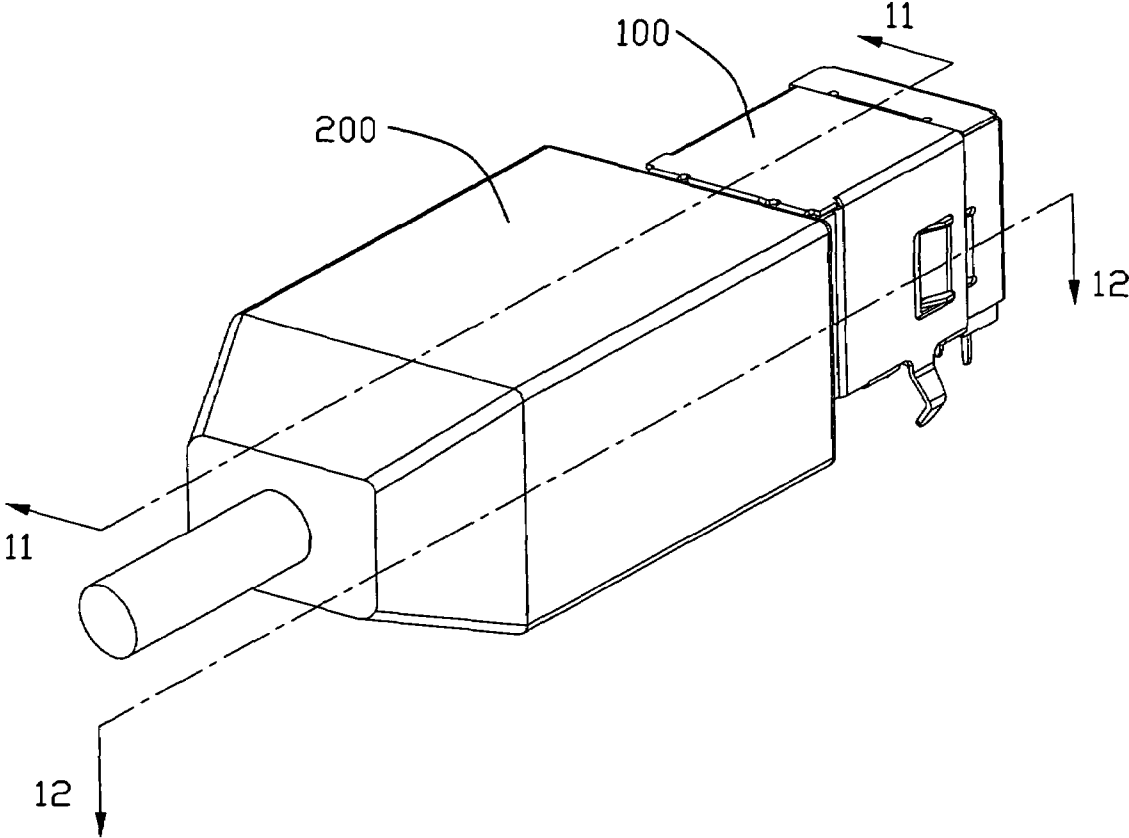

FIG. 10

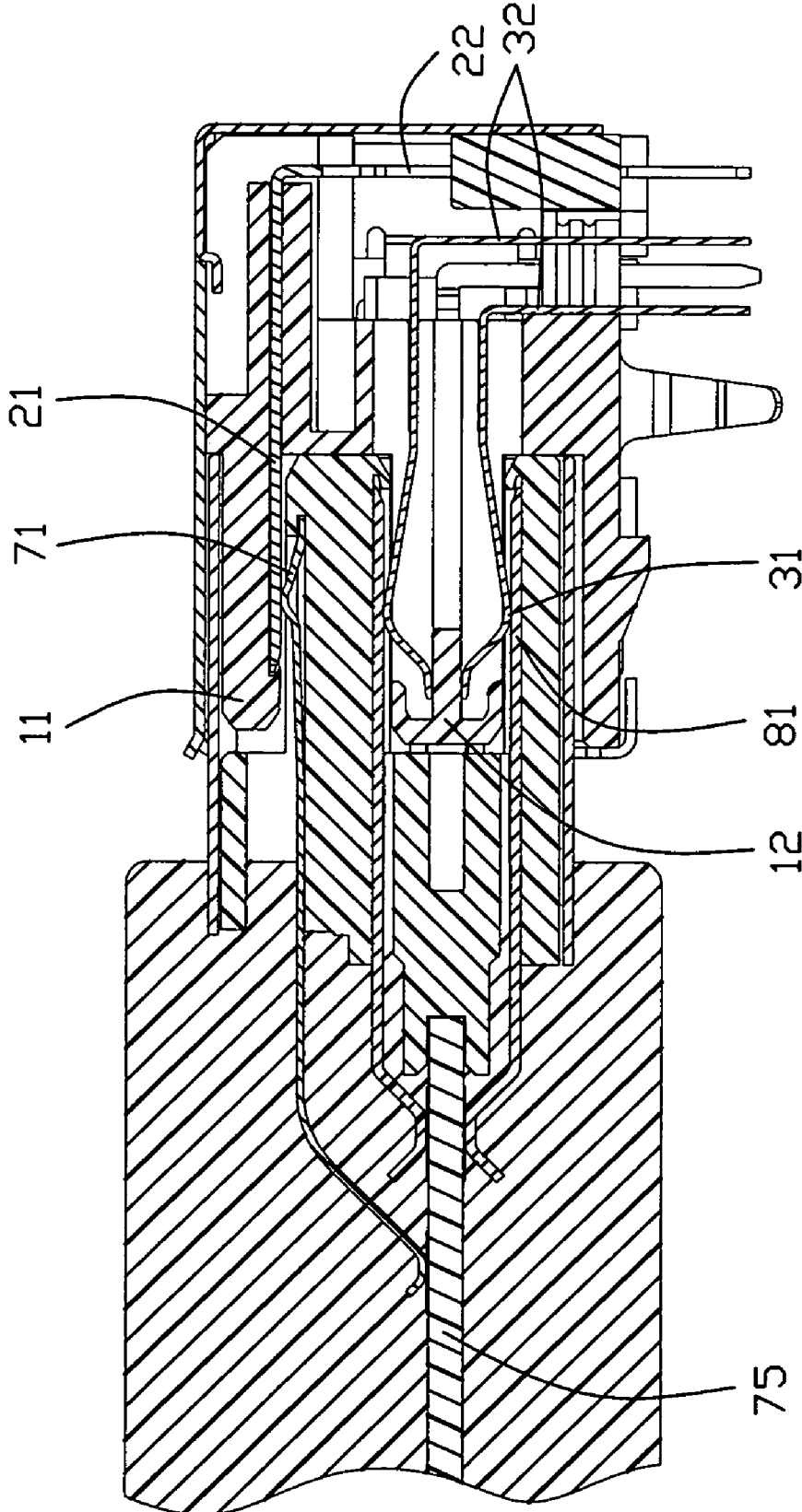

FIG. 11

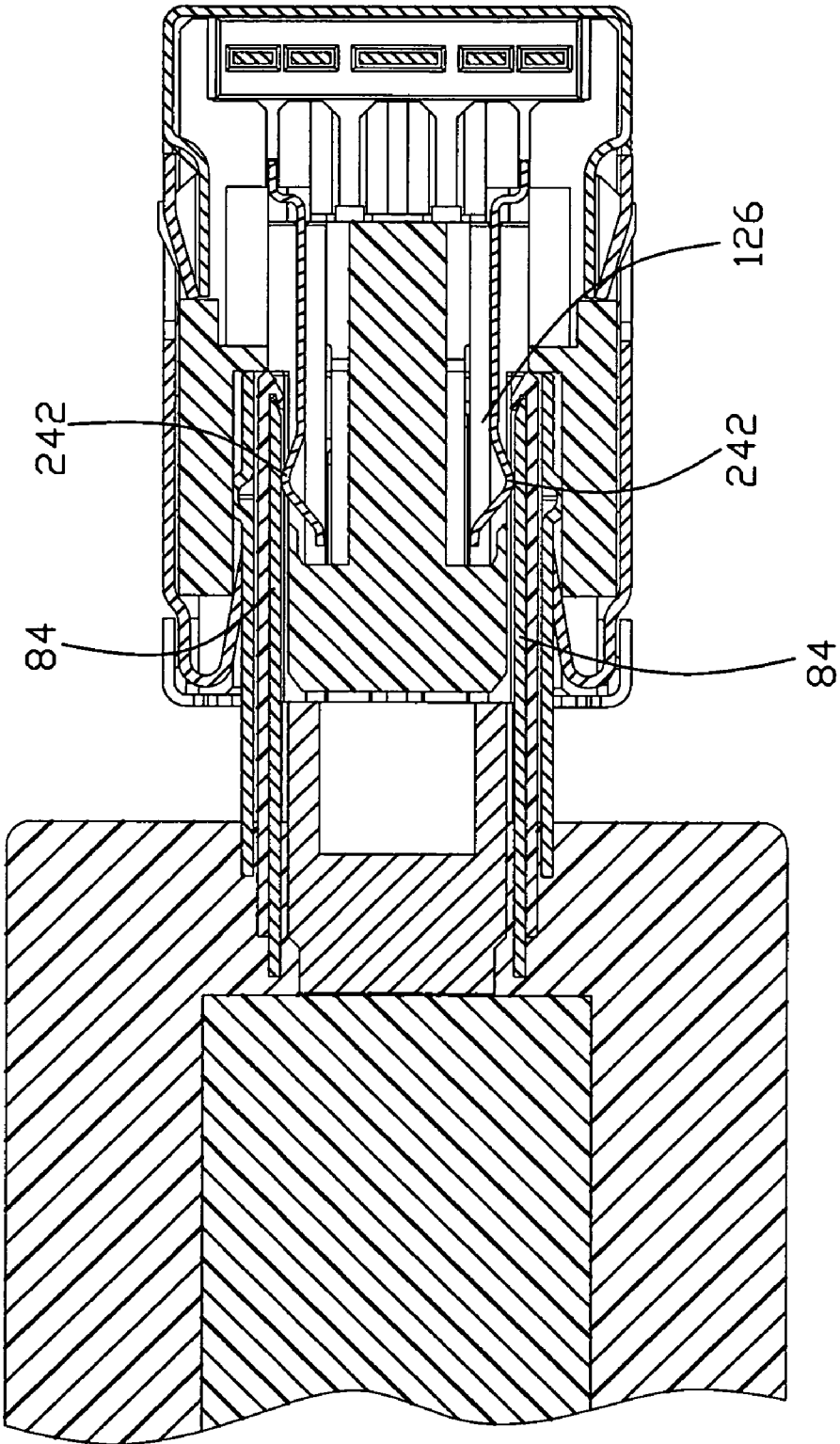

FIG. 12

300

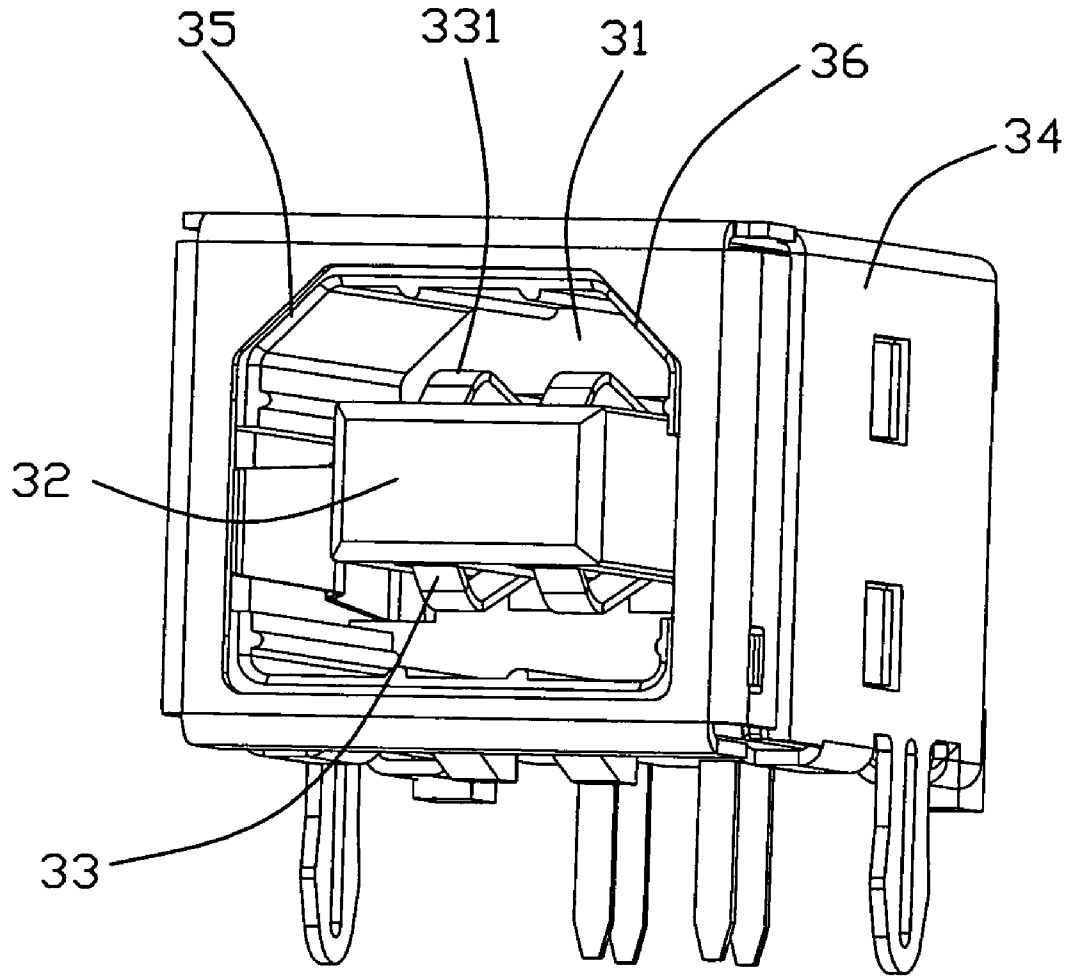

FIG. 13
(PRIOR ART)

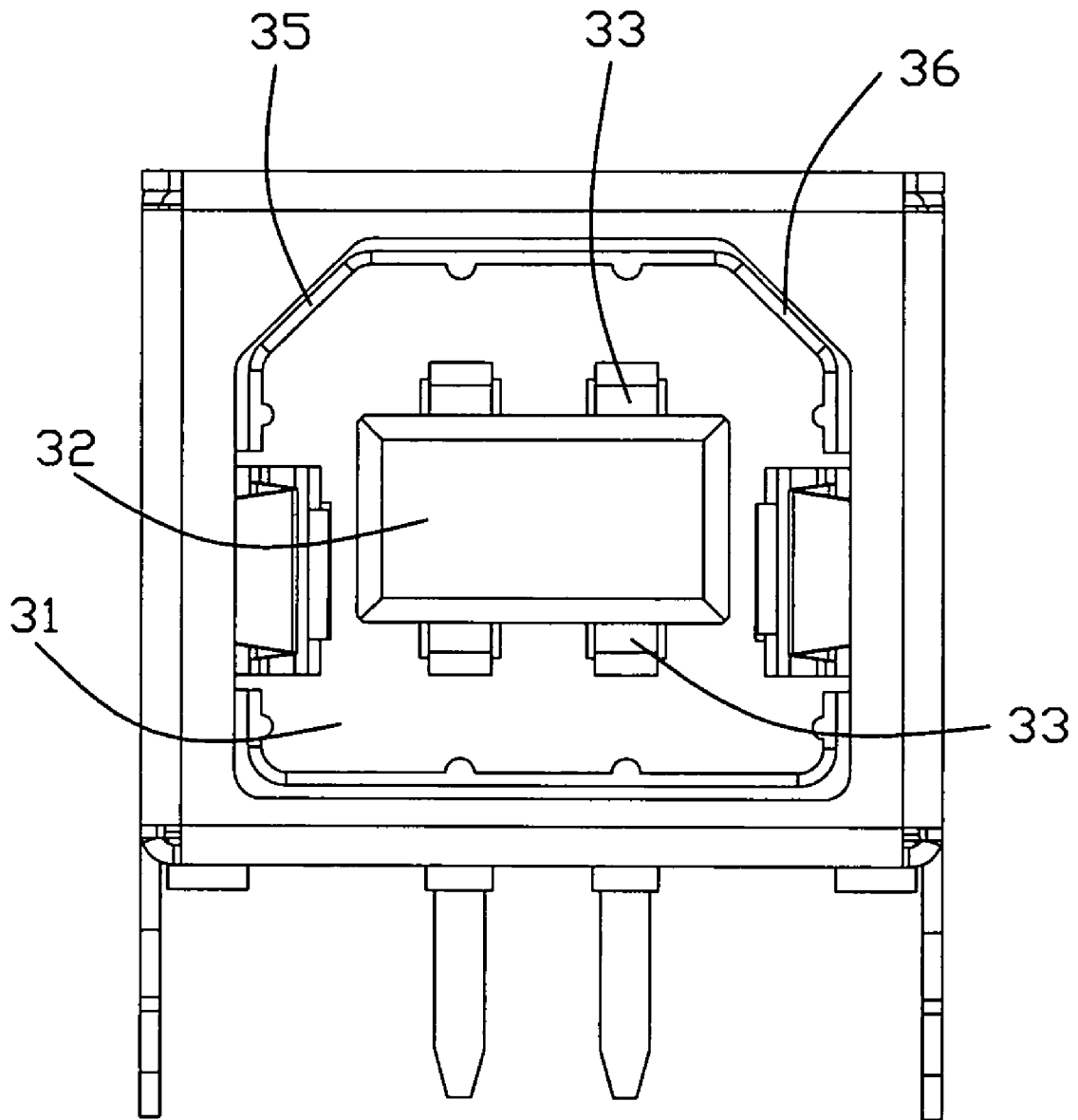

FIG. 14
(PRIOR ART)

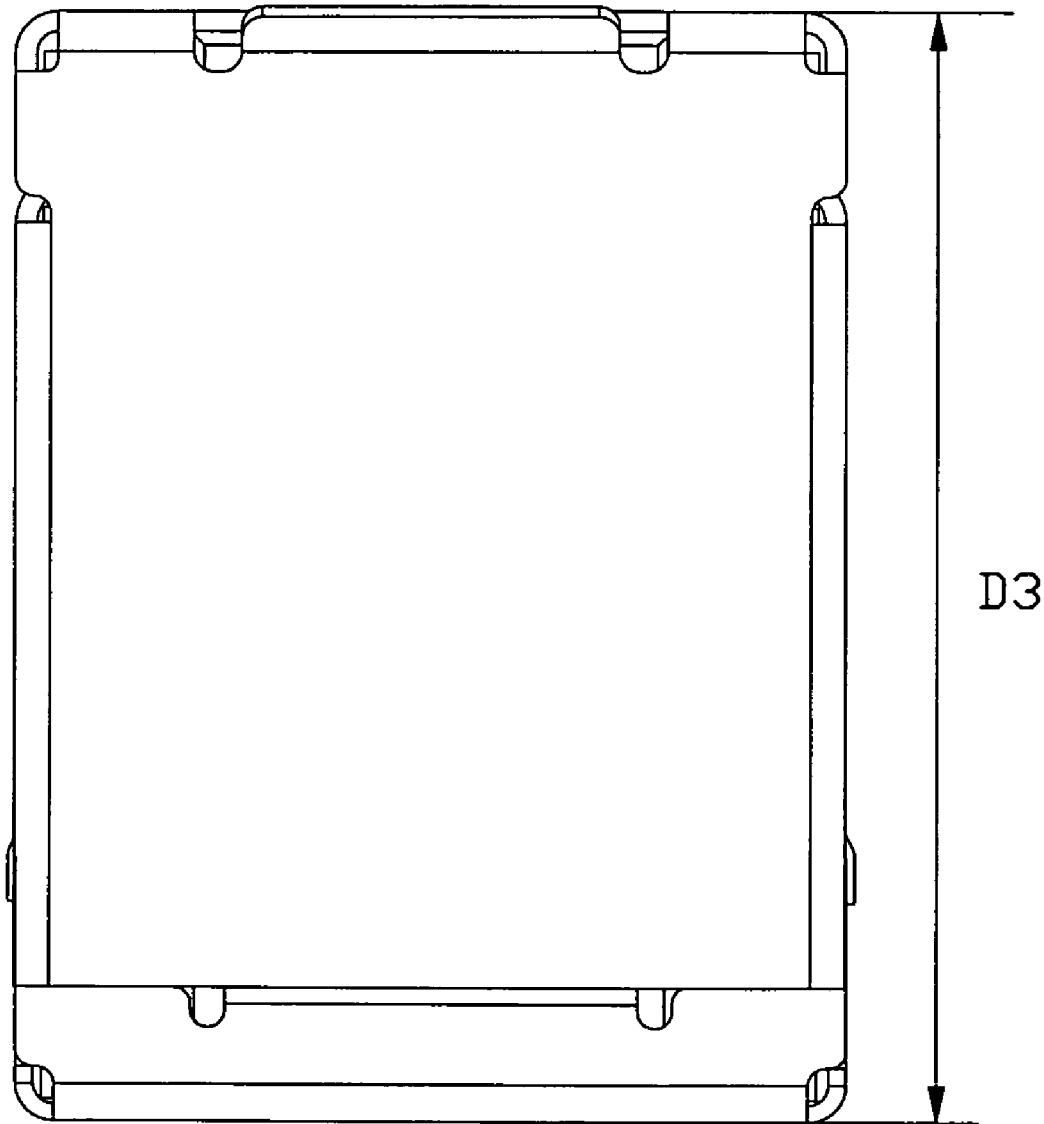

FIG. 15
(PRIOR ART)

400

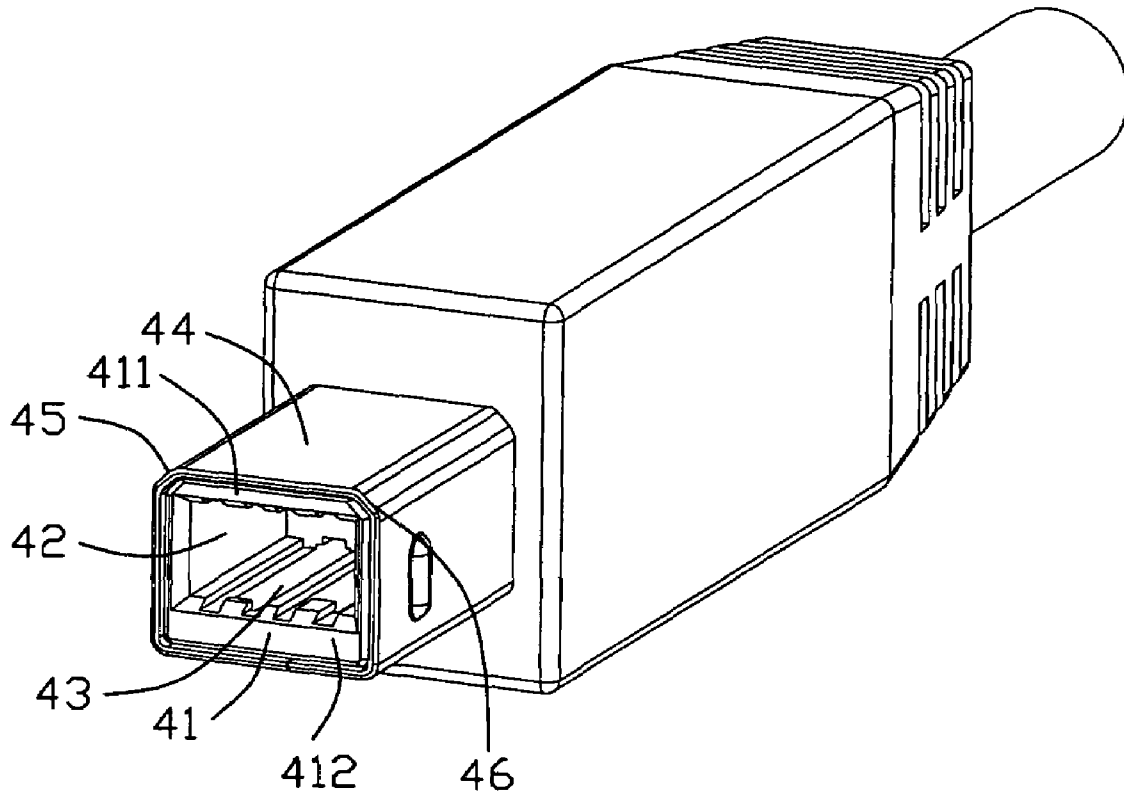

FIG. 16
(PRIOR ART)

ELECTRICAL CONNECTOR WITH POWER CONTACTS

BACKGROUND OF THE INVENTION

1. Field of the Invention

The present invention relates to electrical connectors, more particularly to electrical connectors with power contacts for mating with corresponding connectors.

2. Description of Related Art

Personal computers (PC) are used in a variety of ways for providing input and output. Universal Serial Bus (USB) is a serial bus standard to the PC architecture with a focus on computer telephony interface, consumer and productivity applications. The design of USB is standardized by the USB Implementers Forum (USB-IF), an industry standard body incorporating leading companies from the computer and electronic industries. USB can connect peripherals such as mouse devices, keyboards, PDAs, gamepads and joysticks, scanners, digital cameras, printers, external storage, networking components, etc. For many devices such as scanners and digital cameras, USB has become the standard connection method.

As of 2006, the USB specification was at version 2.0 (with revisions). The USB 2.0 specification was released in April 2000 and was standardized by the USB-IF at the end of 2001. Previous notable releases of the specification were 0.9, 1.0, and 1.1. Equipment conforming to any version of the standard will also work with devices designed to any previous specification (known as: backward compatibility).

USB supports three data rates: 1) A Low Speed rate of up to 1.5 Mbit/s (187.5 KB/s) that is mostly used for Human Interface Devices (HID) such as keyboards, mice, and joysticks; 2) A Full Speed rate of up to 12 Mbit/s (1.5 MB/s); (Full Speed was the fastest rate before the USB 2.0 specification and many devices fall back to Full Speed. Full Speed devices divide the USB bandwidth between them in a first-come first-served basis and it is not uncommon to run out of bandwidth with several isochronous devices. All USB Hubs support Full Speed); 3) A Hi-Speed rate of up to 480 Mbit/s (60 MB/s). Though Hi-Speed devices are commonly referred to as "USB 2.0" and advertised as "up to 480 Mbit/s", not all USB 2.0 devices are Hi-Speed. Hi-Speed devices typically only operate at half of the full theoretical (60 MB/s) data throughput rate. Most Hi-Speed USB devices typically operate at much slower speeds, often about 3 MB/s overall, sometimes up to 10-20 MB/s. A data transmission rate at 20 MB/s is sufficient for some but not all applications. However, under a circumstance transmitting an audio or video file, which is always up to hundreds MB, even to 1 or 2 GB, currently transmission rate of USB is not sufficient.

FIGS. 13 to 16 show existing USB 2.0 connectors. In FIGS. 13 to 15, this USB connector is a standard B-type USB 2.0 receptacle 300. The USB 2.0 receptacle 300 commonly is an integral part of a host or PC. The USB 2.0 receptacle 300 includes a plug-receiving cavity 31, a receptacle tongue plate portion 32 extending into the cavity 31, a plurality of contacts 33 supported by the receptacle tongue plate portion 32, and a metal shield 34 shielding the cavity 31. The tongue plate portion 32 defines a plurality of passageways (not labeled) for receiving the contacts 33. The contacts 33 are located at opposite sides of the tongue plate portion 32. Each contact 33 includes a convex shaped contact section 331 protruding into the cavity 31 for mating with corresponding plug. The USB 2.0 receptacle 300 further has a pair of beveled portions 35, 36 respectively formed on the upper left corner and the upper right corner of the cavity 31 as best shown in FIG. 14.

FIG. 16 shows a standard B-type USB 2.0 plug 400 for mating with the standard USB 2.0 receptacle 300. The USB 2.0 plug 400 includes a plug insulator 41 defining an opening 42, a plurality of contacts 43 retained in the plug insulator 41, and a metal shell 44 enclosing the plug insulator 41. The plug insulator 41 includes an upper wall 411 and a lower wall 412 with the opening 42 formed therebetween. The contacts 43 are plate-shaped and non-elastic in order to be retained on inner surfaces of the upper and lower walls 411, 412, respectively. The USB 2.0 plug 400 further includes a pair of slant portions 45, 46 located on top lateral sides thereof for mating with the corresponding beveled portions 35, 36 of the USB 2.0 receptacle 300 in order to guide correct insertion of the USB 2.0 plug 400.

Usually, the USB receptacle is mounted on a PCB of a host device such as a personal computer, and the USB plug is connected to a peripheral device such as a mouse for mating with the USB receptacle. However, with some peripheral devices connected by a standard B-type USB connector, it is desired to transmit signals to and from another device directly, without passing through the host device. Under this condition, because one of the peripheral devices must function as a host device, it is necessary to be able to transmit a voltage between relevant peripheral devices to activate the host function.

As discussed above, with limited data transmission speed of the USB 2.0 connectors, there is a need to design electrical connectors with additional mating ports for high-speed signal transmission, and with improved power contacts for voltage transmission.

BRIEF SUMMARY OF THE INVENTION

An electrical connector includes an electrical receptacle and an electrical plug for mating with the electrical receptacle. The electrical receptacle includes a first receiving cavity, a second receiving cavity communicating with the first receiving cavity, a first tongue portion extending into the first receiving cavity and a second tongue portion extending into the second receiving cavity. A plurality of first contacts are disposed on a mounting surface of the first tongue portion. A plurality of second contacts are disposed on opposite first and second surfaces of the second tongue portion and protrude into the second receiving cavity. A plurality of power contacts are located on lateral sides of the second tongue portion and extend into the second receiving cavity. The first and the second tongue portions are parallel to each other among which the second tongue portion is much thicker than the first tongue portion.

An electrical plug includes a first opening, a second opening and a metal shield shielding the first and the second openings. A plurality of first plug contacts protrude into the first opening. A plurality of second plug contacts are exposed to the second opening. A plurality of plug power contacts are disposed on lateral sides of the second opening. The first and the second openings are separated by a separate plate in condition that the first and the second plug contacts are disposed on opposite first and second sides of the separate plate, respectively.

The foregoing has outlined rather broadly the features and technical advantages of the present invention in order that the detailed description of the invention that follows may be better understood. Additional features and advantages of the

invention will be described hereinafter which form the subject of the claims of the invention.

BRIEF DESCRIPTION OF THE DRAWINGS

For a more complete understanding of the present invention, and the advantages thereof, reference is now made to the following descriptions taken in conjunction with the accompanying drawings, in which:

FIG. 1 is a perspective view of an electrical receptacle according to a preferred embodiment of the present invention;

FIG. 2 is an exploded perspective view of the electrical receptacle;

FIG. 3 is another exploded perspective view of the electrical receptacle, but taken from another aspect;

FIG. 4 is a front view of the electrical receptacle shown in FIG. 1;

FIG. 5 is a top view of the electrical receptacle shown in FIG. 1;

FIG. 6 is a perspective view of an electrical plug which can be inserted into the electrical receptacle;

FIG. 7 is an exploded perspective view of the electrical plug;

FIG. 8 is another exploded perspective view of the electrical plug, while taken from another aspect;

FIG. 9 is a front view of the electrical plug shown in FIG. 6;

FIG. 10 is a perspective view of the electrical plug and receptacle, showing a state that the electrical plug is fully inserted into the electrical receptacle;

FIG. 11 is a cross-sectional view of the electrical plug and receptacle taken along line 11-11 of FIG. 10, showing contacts mating with each other;

FIG. 12 is a cross-sectional view of the electrical plug and receptacle taken along line 12-12 of FIG. 10, showing power contacts mating with each other;

FIG. 13 is a perspective schematic view of a standard B-type USB 2.0 receptacle;

FIG. 14 is a front view of the standard B-type USB 2.0 receptacle shown in FIG. 13;

FIG. 15 is a top view of the standard B-type USB 2.0 receptacle shown in FIG. 13; and

FIG. 16 is a perspective view of a standard B-type USB 2.0 plug.

DETAILED DESCRIPTION OF THE PREFERRED EMBODIMENT

In the following description, numerous specific details are set forth to provide a thorough understanding of the present invention. However, it will be obvious to those skilled in the art that the present invention may be practiced without such specific details. In other instances, well-known circuits have been shown in block diagram form in order not to obscure the present invention in unnecessary detail. For the most part, details concerning timing considerations and the like have been omitted inasmuch as such details are not necessary to obtain a complete understanding of the present invention and are within the skills of persons of ordinary skill in the relevant art.

Within the following description, a standard USB 2.0 connector, receptacle, plug, and signaling all refer to the USB architecture described within the Universal Serial Bus Specification, 2.0 Final Draft Revision, Copyright December, 2002, which is hereby incorporated by reference herein.

Referring to FIG. 10, an electrical connector of the preferred embodiment includes an electrical receptacle 100 and

an electrical plug 200 for mating with the electrical receptacle 100. The electrical receptacle 100 is mounted on a Printed Circuit Board (PCB, not shown) and includes an insulative housing 1, a plurality of first and second contacts 2, 3 retained in the insulative housing 1, a pair of power contacts 24 and a metal shield 4 enclosing the insulative housing 1 for EMI protection.

Referring to FIGS. 1-4, the insulative housing 1 is formed by plastic injection molding to have a base portion 10, a pair of first and second tongue portions 11, 12 extending forwardly from the base portion 10. The insulative housing 1 defines a first receiving cavity 110 with the first tongue portion 11 extending thereinto, and a second receiving cavity 120 with the second tongue portion 12 extending thereinto. The first and the second receiving cavities 110, 120 communicate with each other wherein the second receiving cavity 120 is much larger than the first receiving cavity 110. In detail, as shown in FIG. 4, the width W2 of the second receiving cavity 120 is larger than the width W1 of the first receiving cavity 110. The height H2 of the second receiving cavity is also larger than the height H1 of the first receiving cavity 110. The first receiving cavity 110 is substantially rectangular shaped. The insulative housing 1 has a chamfered portion 13 and a right angle portion 14 on its upper left corner and upper right corner, respectively. The right angle portion 14 and the chamfered portion 13 are located between the first and the second tongue portions 11, 12 along a vertical direction as shown in FIG. 9. The chamfered portion 13 and right angle portion 14 act as keys for regulating the insertion orientation of the electrical plug 200 or the standard B-type USB 2.0 plug as shown in FIG. 16. In the preferred embodiment of the present invention, the first and the second tongue portions 11, 12 are stacked in a vertical direction. The first tongue portion 11 is an upper one and the second tongue portion 12 is a lower one. The first tongue portion 11 includes a plurality of grooves 112 recessed from a mounting surface 111 thereof for receiving the first contacts 2. The second tongue portion 12 is much thicker than the first tongue portion 11 along the vertical direction as best shown in FIG. 4. The second tongue portion 12 includes opposite first and second walls 121, 122 on upper and lower sides thereof, and a pair of side walls 125 connecting the first and the second walls 121, 122. The first and the second walls 121, 122 define a pair of passageways 123, 124, respectively, for receiving the second contacts 3. The mounting surface 111 is a lower surface of the first tongue portion 11 so that the mounting surface 111 is much closer to the first wall 121 than to the second wall 122. That is to say, the mounting surface 111 directly faces the first wall 121. Each side wall 125 defines a depression 126 (as shown in FIG. 12) for receiving the power contacts 24 as shown in FIGS. 4 and 12.

The first contacts 2 of the preferred embodiment are non-elastic. Each first contact 2 comprises a plate-shaped contact portion 21, a bending portion 22 perpendicular to the contact portion 21 and a tail portion 23 on a distal end of the bending portion 22. The contact portions 21 are attached to the grooves 111 of the first tongue portion 11 so that they can be exposed to the first receiving cavity 110 for mating with the electrical plug 200. As best shown in FIG. 1, the first contacts 2 of the preferred embodiment includes a middle grounding contact and two pairs of first and second signal contacts respectively disposed on lateral sides of the grounding contact. The grounding contact attached on the mounting surface 111 of the first tongue portion 11 is longer than that of the first or the second signal contact so that the front end of the grounding contact is much closer to a free end of the first tongue portion 11. With insertion of the electrical plug 200,

5

the electrical plug **200** contacts the grounding contact first and then contacts the first and second signal contacts for better grounding protection.

The second contacts **3** of the preferred embodiment are elastic. Each second contact **3** comprises a convex shape elastic contact section **31**, a bending section **32** perpendicular to the contact section **31** and a tail section **33** on a distal end of the bending section **32**. The contact sections **31** are located on the passageways **123**, **124** of the second tongue portion **12** and extend beyond the first and the second walls **121**, **122** to protrude into the second receiving cavity **120**.

Each power contact **24** of the preferred embodiment includes a retaining portion **241**, a convex shape elastic contact section **242** extending forwardly from the retaining portion **241**, an offset portion **243** extending outwardly from the retaining portion **241** and a soldering portion **244** extending downwardly from the retaining portion **241**. The retaining portions **241** are partly retained in the corresponding depressions **126** of the second tongue portion **12**. The contact sections **242** sidewardly protrude into the second receiving cavity **120** for mating with the electrical plug **200** as best shown in FIG. **12**.

In assembly, the bending portions **22** of the first contacts **21** are located on peripheral side of the bending sections **32** of the second contacts **3** so that the depth **D1** of electrical receptacle **100** is much larger than the corresponding depth **D3** of the existing B-type USB 2.0 receptacle **300** as shown in FIGS. **5** and **15**.

The electrical receptacle **100** includes a lower port compatible to the existing standard B-type USB 2.0 plug shown in FIG. **16** and an additional upper port for transmitting high-speed signals in order to improve the transmission speed. The upper and the lower ports are simultaneously combined to receive the electrical plug **200**. It is obvious that the whole height of the electrical receptacle **100** is much larger than that of the standard B-type USB 2.0 receptacle because of the existing of the upper port.

In order to organize all the tail portions **23**, the tail sections **33** and the soldering portions **244**, the electrical receptacle **100** includes a spacer **5** attached to a rear face **13** of the insulative housing **1**. The spacer **5** defines a plurality of through holes **51** for the tail portions **23**, the tail sections **33** and the soldering portions **244** extending therethrough so that they can be easily mounted to the PCB.

The metal shield **4** includes a front metal shield **41** enclosing the insulative housing **1**, a rear metal shield **42** attached to the front metal shield **41**. The front metal shield **41** is stamped from a unitary one-piece metal sheet to have a top wall **411**, a pair of side walls **412** and a pair of front walls **413** bending inwardly from front ends of the side walls **412**. Each side wall **412** includes an engaging arm **414** extending into the second receiving cavity **120** for abutting against the electrical plug **200** or the standard B-type USB 2.0 plug **400**. Each side wall **414** further includes a plurality of supporting portions **415** abutting against the spacer **5** so that the spacer **5** can be firmly fixed to the insulative housing **1**. The rear metal shield **42** includes a rear wall **421** attached to the insulative housing **1** and a pair of arms **422** abutting against the side wall **412** of the front metal shield **41**.

The electrical plug **200** includes an insulator **6**, a plurality first and second plug contacts **7**, **8** retained in the insulator **6**,

6

a pair of plug power contacts **84**, a metal shell **9** enclosing the insulator **9**, an inner PCB **75** and a cable **60** electrically connecting with the first and the second plug contacts **7**, **8** as well as the plug power contacts **84**. The insulator **6** is frame-shaped and includes an upper separate plate **61**, a bottom portion **62** opposite to the separate plate **61** and a pair of side portions **63** connecting the separate plate **61** and the bottom portion **62**. The metal shell **9** has a lower portion **91** and an upper portion **92** narrower than the lower portion **91**. The upper portion **92** includes a top wall **921** and a pair of first side walls **922**. The lower portion **91** includes a bottom wall **911** attached to the bottom portion **62** of the insulator **6**, and a pair of second side walls **912** attached to the side portions **63** of the insulator **6**. The separate plate **61** includes a slant portion **611** and a substantial right angle portion **614** on lateral sides thereof as shown in FIG. **9**. The second side walls **912** comprise a corresponding slant section **913** and a corresponding right angle section **914** attached to the slant portion **611** and the substantial right angle portion **614** for mating with the chamfered portion **13** and right angle portion **14** of the electrical receptacle **100**. A first opening **64** is enclosed by the top wall **921**, a pair of first side walls **922** and the separate plate **61**. The insulator **6** defines a second opening **65** enclosed by the separate plate **61**, the pair of side portions **63** and the bottom portion **62**. That is to say the first and the second openings **64**, **65** are separated by the separate plate **61** which includes a first side **612** exposing to the first opening **64** and a second side **613** exposing to the second opening **65**. The second opening **65** is much bigger than the first opening both in height and width as best shown in FIG. **9**. The first plug contacts **7** are elastic and include elastic engaging sections **71** extending into the first opening **64** for abutting against the contact portions **21** of first contacts **2**. The second plug contacts **8** are attached to the second side **613** of the separate plate **61** and an inner side **621** of the bottom portion **62**, respectively. The second plug contacts **8** are non-elastic and include plate-shaped mating sections **81** exposed to the second opening **65** for abutting against the elastic contact sections **31** of the second contacts **3**. Each plug power contact **84** includes a stiff contact portion **85** for abutting against the corresponding contact section **242** of the electrical receptacle **100**. The contact portions **85** of the plug power contacts **84** are attached to inner sides of the side portions **63** and exposed to the second opening **65**. In the preferred embodiment of the present invention, the first and the second plug contacts **7**, **8** as well as the plug power contacts **84** electrically connect to the cable **60** through the inner PCB **75**.

In FIGS. **10** and **11**, a mating status of the electrical plug **200** fully insertion into the electrical receptacle **100** is shown. After the electrical plug **200** is fully inserted into the electrical receptacle **100**, all plug contacts **7**, **8** physically contact corresponding contacts **2**, **3** of the electrical receptacle **100** as clearly shown in FIG. **11**. Since the electrical receptacle **100** is compatible to the existing standard B-type USB 2.0 plug **400**, with insertion of the standard B-type USB 2.0 plug **400**, only the second contacts **3** of the electrical receptacle **100** abut against the contacts **43** of the B-type USB 2.0 plug **400**.

As shown in FIG. **12**, with fully insertion of the electrical plug **200** into the electrical receptacle **100**, the contact por-

tions **85** of the plug power contacts **84** abut against the contact sections **242** of the corresponding power contacts **24** for voltage transmission.

It is to be understood, however, that even though numerous characteristics and advantages of the present invention have been set forth in the foregoing description, together with details of the structure and function of the invention, the disclosure is illustrative only, and changes may be made in detail, especially in matters of shape, size, and arrangement of parts within the principles of the invention to the full extent indicated by the broad general meaning of the terms in which the appended claims are expressed. For example, the tongue portion is extended in its length or is arranged on a reverse side thereof opposite to the supporting side with other contacts but still holding the contacts with an arrangement indicated by the broad general meaning of the terms in which the appended claims are expressed.

We claim:

1. An electrical receptacle, comprising:

a first receiving cavity with a first tongue portion extending thereinto;

a second receiving cavity communicating with the first receiving cavity with a second tongue portion extending thereinto, the first and the second tongue portions being parallel to each other while the second tongue portion being thicker than the first tongue portion;

a plurality of first contacts disposed on a mounting surface of the first tongue portion; and

a plurality of second contacts disposed on opposite first and second walls of the second tongue portion and protruding into the second receiving cavity;

wherein the second tongue portion comprises two lateral sides between the first and the second walls in condition that a plurality of power contacts are disposed on the lateral sides of the second tongue portion, wherein herein the first contacts are non-elastic and exposed to the first receiving cavity, the second contacts being elastic and comprising convex portions extending into the second receiving cavity and an insulative housing with the first and the second receiving cavities defined therein, the insulative housing comprising a chamfered portion and a right angle portion on lateral sides thereof, wherein the chamfered portion and the right angle portion are located between the first and the second tongue portions along a vertical direction.

2. The electrical receptacle as claimed in claim **1**, wherein the mounting surface is much closer to the first wall of the second tongue portion than to the second wall of the second tongue portion so that the mounting surface directly faces the first wall of the second tongue portion, the first contacts being plate-shaped and disposed on the mounting face.

3. The electrical receptacle as claimed in claim **1**, wherein the second contacts include two contacts disposed on the first wall of the second tongue portion, and two contacts disposed on the second wall of the second tongue portion.

4. The electrical receptacle as claimed in claim **1**, wherein the power contacts comprise contact sections protruding into the second receiving cavity.

5. The electrical receptacle as claimed in claim **1**, wherein the first tongue portion is located upper the second tongue portion, the mounting surface being a lower surface of the first tongue portion, the first and the second walls being opposite upper and lower walls of the second tongue portion, respectively.

6. The electrical receptacle as claimed in claim **1**, wherein the second contacts are for USB 2.0 protocol, the second receiving cavity being of corresponding shape to accommodate a standard B-type USB 2.0 plug.

7. The electrical receptacle as claimed in claim **6**, wherein the second receiving cavity is much higher than the first receiving cavity, the first and the second receiving cavities being combined to receive another electrical plug.

8. The electrical receptacle as claimed in claim **1**, wherein the electrical receptacle is much higher and deeper than that of a standard B-type USB 2.0 receptacle.

9. The electrical receptacle as claimed in claim **1**, wherein the first receiving cavity is narrower than the second receiving cavity.

10. An electrical plug, comprising:

a first opening with a plurality of first plug contacts protruding thereinto;

a second opening with a plurality of second plug contacts exposed thereto;

the first and the second openings being separated by a separate plate in condition that the first and the second plug contacts are disposed on opposite first and second sides of the separate plate, respectively; and

a pair of plug power contacts with contact portions located on opposite lateral sides of the second opening, and the contact portions being exposed to the second opening and a frame-shaped insulator having the separate plate, a bottom portion opposite to the separate plate and a pair of side portions connecting the separate plate and the bottom portion, the second opening being enclosed by the separate plate, the bottom portion and the pair of side portions, wherein the contact portions of the plug power contacts are stiff shaped, the contact portions being retained on the side portions of the insulator and a metal shell enclosing the insulator, the metal shell comprising a top wall, a pair of side walls partly abutting against the side portions of the insulator, and a bottom wall attached to the bottom portion of the insulator, the first opening being formed by the top wall, parts of the side walls and the separate plate and wherein one side wall of the metal shell comprises a right angle portion substantially on its middle portion, the other side wall of the metal shell comprising a slant portion opposite to the right angle portion.

11. An electrical connector comprising:

a first connector including a first insulative housing and defining a first mating port with a first mating tongue forwardly extending in said first mating port;

said first mating tongue defining a first horizontal mating face and a first vertical mating face adjacent to each other;

a plurality of first horizontal contacts disposed in the first housing, each of said first horizontal contacts having a first deflectable contacting section exposed upon the first horizontal mating face; and

at least a first vertical contact disposed in the first housing, said at least one first vertical contacts having a first resilient contacting section exposed upon the first vertical mating face; wherein

said first horizontal mating face define recesses each to receive the first deflectable contacting section, and said first vertical mating face defines at least one recess to receive the first resilient contacting section, wherein a first metallic shell encloses the first housing, and said first shell defines at least one resilient side wall backwardly extending from a front face of the shell into the first mating port and directly facing the corresponding

9

first vertical mating face so as to cooperate with the first resilient contacting section for sandwiching an inserted second connector therebetween, wherein said second connector defines a second insulative housing with a second mating port therein, a second horizontal mating face and a second vertical mating face being formed in the mating port and adjacent to each other, a plurality of second horizontal contacts disposed in the second housing, each of said second horizontal contacts having a second stiff contacting section exposed on the second horizontal mating face, a plurality of second vertical

10

contacts disposed in the second housing, each of said second vertical contacts having a second rigid contacting section exposed on the second vertical mating face, wherein said first connector further include another mating port communicatively stacked with the first mating port, and said another mating port is equipped with another mating tongue with a plurality of third contacts thereof each defining a stiff contacting part exposed to a mating surface of said another mating tongue and directly facing the first deflectable contacting sections.

* * * * *