

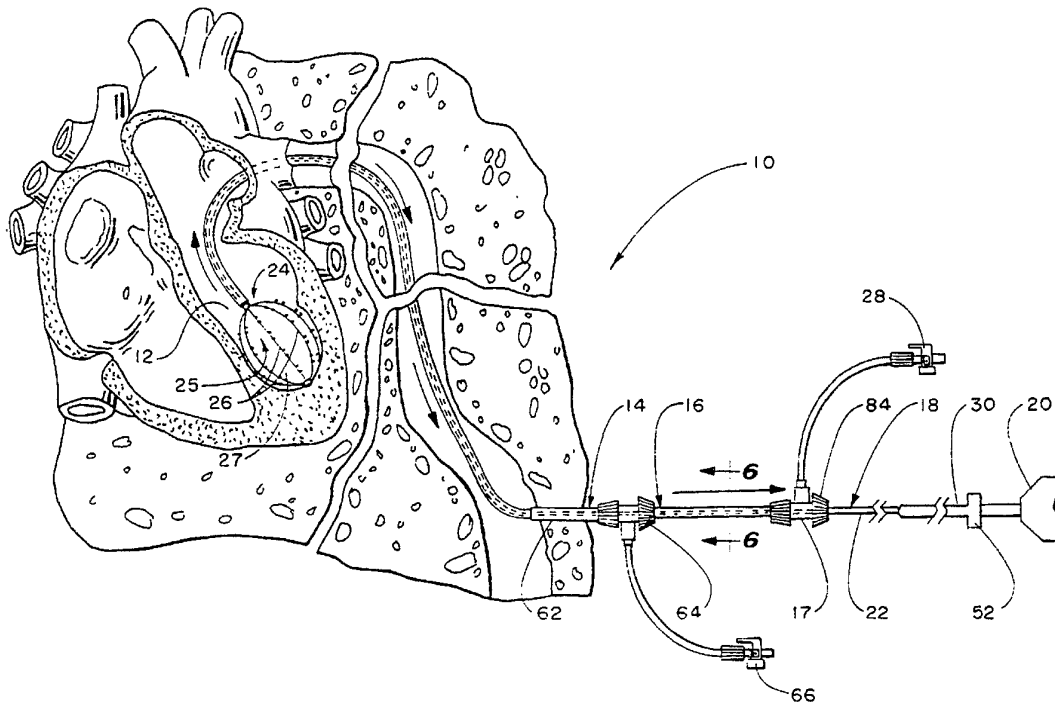

INTERNATIONAL APPLICATION PUBLISHED UNDER THE PATENT COOPERATION TREATY (PCT)

<p>(51) International Patent Classification⁵ : A61B 5/04</p>	<p>A1</p>	<p>(11) International Publication Number: WO 94/21165 (43) International Publication Date: 29 September 1994 (29.09.94)</p>
<p>(21) International Application Number: PCT/US94/02780 (22) International Filing Date: 15 March 1994 (15.03.94) (30) Priority Data: 08/033,641 16 March 1993 (16.03.93) US (71) Applicant: EP TECHNOLOGIES, INC. [US/US]; 350 Potrero Avenue, Sunnyvale, CA 94086 (US). (72) Inventors: KORDIS, Thomas, F.; 101 Weddell Drive, No. 26, Sunnyvale, CA 94086 (US). JACKSON, Jerome; 880 East Fremont Avenue, No. 322, Sunnyvale, CA 94087 (US). LASERSOHN, Jack, W.; 1405 White Rock Road, Los Gatos, CA 95030 (US). (74) Agents: HOHENFELDT, Ralph, G. et al.; 633 West Wisconsin Avenue, Milwaukee, WI 53203 (US).</p>	<p>(81) Designated States: CA, JP, European patent (AT, BE, CH, DE, DK, ES, FR, GB, GR, IE, IT, LU, MC, NL, PT, SE). Published <i>With international search report. Before the expiration of the time limit for amending the claims and to be republished in the event of the receipt of amendments.</i></p>	

(54) Title: GUIDE SHEATHS FOR CARDIAC MAPPING AND ABLATION



(57) Abstract

A steerable first catheter (14) directs the introduction of a guide sheath (16), which can otherwise be free of any onboard steering mechanism. The guide sheath (16), in turn, directs the introduction of an electrode carrying second catheter (18), which can likewise be free of any onboard steering mechanism. Use of a guide sheath positioned by a separate, dedicated steering catheter to guide a separate, dedicated steering electrode carrying catheter results in a significant reduction in the overall size of the system components.

FOR THE PURPOSES OF INFORMATION ONLY

Codes used to identify States party to the PCT on the front pages of pamphlets publishing international applications under the PCT.

AT	Austria	GB	United Kingdom	MR	Mauritania
AU	Australia	GE	Georgia	MW	Malawi
BB	Barbados	GN	Guinea	NE	Niger
BE	Belgium	GR	Greece	NL	Netherlands
BF	Burkina Faso	HU	Hungary	NO	Norway
BG	Bulgaria	IE	Ireland	NZ	New Zealand
BJ	Benin	IT	Italy	PL	Poland
BR	Brazil	JP	Japan	PT	Portugal
BY	Belarus	KE	Kenya	RO	Romania
CA	Canada	KG	Kyrgyzstan	RU	Russian Federation
CF	Central African Republic	KP	Democratic People's Republic of Korea	SD	Sudan
CG	Congo	KR	Republic of Korea	SE	Sweden
CH	Switzerland	KZ	Kazakhstan	SI	Slovenia
CI	Côte d'Ivoire	LI	Liechtenstein	SK	Slovakia
CM	Cameroon	LU	Luxembourg	SN	Senegal
CN	China	LK	Sri Lanka	TD	Chad
CS	Czechoslovakia	LV	Latvia	TG	Togo
CZ	Czech Republic	MC	Monaco	TJ	Tajikistan
DE	Germany	MD	Republic of Moldova	TT	Trinidad and Tobago
DK	Denmark	MG	Madagascar	UA	Ukraine
ES	Spain	ML	Mali	US	United States of America
FI	Finland	MN	Mongolia	UZ	Uzbekistan
FR	France			VN	Viet Nam
GA	Gabon				

Guide Sheaths for Cardiac Mapping and Ablation

Field of the Invention

5 The invention relates to systems and methods for mapping and ablating the interior regions of the heart for treatment of cardiac conditions.

Background of the Invention

10 Physicians make use of catheters today in medical procedures to gain access into interior regions of the body to ablate targeted tissue areas. It is important for the physician to be able to carefully and precisely control the position of the catheter and its emission of energy within the body
15 during tissue ablation procedures.

 The need for careful and precise control over the catheter is especially critical during procedures that ablate tissue within the heart. These procedures, called electrophysiological therapy,
20 are becoming more widespread for treating cardiac rhythm disturbances.

 During these procedures, a physician steers a catheter through a main vein or artery into the interior region of the heart that is to be treated.
25 The physician then further manipulates a steering

- 2 -

mechanism to place the electrode carried on the distal tip of the catheter into direct contact with the tissue that is to be ablated. The physician directs energy from the electrode through tissue to an indifferent electrode (in a uni-polar electrode arrangement) or to an adjacent electrode (in a bi-polar electrode arrangement) to ablate the tissue and form a lesion.

Cardiac mapping can be used before ablation to locate aberrant conductive pathways within the heart. The aberrant conductive pathways constitute peculiar and life threatening patterns, called dysrhythmias. Mapping identifies regions along these pathways, called foci, which are then ablated to treat the dysrhythmia.

There is a need for cardiac mapping and ablation systems and procedures that can be easily deployed with a minimum of manipulation and effort.

There is also a need for systems and procedures that are capable of performing cardiac mapping in tandem with cardiac ablation. Such multipurpose systems must also be easily introduced into the heart. Once deployed, such multipurpose systems also must be capable of mapping and ablating with a minimum of manipulation and effort.

Summary of the Invention

A principal objective of the invention is to provide improved systems and methodologies to carry out cardiac mapping and/or cardiac ablation procedures quickly and accurately.

One aspect of the invention provides improved catheter systems for use within the heart for endocardial mapping or ablation. The systems employ a guide sheath to facilitate advancement, deployment, and stabilization of catheter bodies

- 3 -

inside a selected heart region.

In one embodiment, the system employs separate first and second catheter bodies in association with the guide sheath.

5 In this arrangement, the first catheter body includes a mechanism for deflecting its distal end, so that it can be steered into a selected heart region. The separate second catheter body has a distal tip that carries at least one operative element that is capable of performing a diagnostic or
10 therapeutic function within the heart. In a preferred embodiment, the functional element is an electrode.

 The guide sheath has an interior bore. In
15 a first mode of use, the guide sheath bore receives the first catheter body. Following the first catheter body, the guide sheath is advanced into the selected heart region. The bore thereby presents a passage leading to the selected heart region.

20 In a second mode of use, the guide sheath bore receives the second catheter body. The bore guides the advancement of the second catheter body into the selected heart region for deployment of the functional element it carries.

25 According to this aspect of the invention, the steerable first catheter directs the introduction of the guide sheath, which can otherwise be free of any onboard steering mechanism. The guide sheath, in turn, directs the introduction of the
30 functional element carried by the second catheter, which can likewise be free of any onboard steering mechanism. Use of a sheath that is positioned by a separate, dedicated steering catheter to then guide a separate, dedicated diagnostic or therapeutic
35 catheter results in a significant reduction in

- 4 -

the overall size of the system components.

According to another aspect of the invention, the second catheter body carries on its distal end a three dimensional structure with an open interior area. In addition, this embodiment of the system employs a third catheter body. The third catheter body carries an ablating element on its distal end.

In this arrangement, the guide sheath, serves three functions.

First, the guide sheath receives the first catheter body for advancement, guided by the first catheter body, into the selected heart region.

Second, the guide sheath receives the second catheter body to guide the advancement of the second catheter body into the selected heart region with the three dimensional structure captured and collapsed within the guide sheath.

Third, the guide sheath is movable away from the distal end of the second catheter body to free the three dimensional structure from the guide sheath.

When free of the guide sheath, the interior of the three dimensional structure opens to receive the ablating element carried by the distal end of the third catheter body. The three dimension structure serves to stabilize the ablating element while being used to ablate myocardial tissue.

In this embodiment, the guide sheath can be selectively moved toward and away from the distal end of the second catheter to successively retain and deploy the three dimensional structure while within the heart region.

The invention also provides alternative configurations for three dimensional probe stabiliz-

- 5 -

ing structures.

In one alternative embodiment, the three dimensional structure comprises a single length of wire shaped to enclose an open interior area.

5 In another embodiment, the three dimensional structure comprises at least two loops that project outwardly beyond the distal tip, with one loop nested within the other loop. In this embodiment, the loops are free of connection at their distal ends and can thus flex independently of each other.

In a preferred embodiment, the three dimensional structure defines a multiple spline basket.

15 The invention also provides various methodologies for using a separate guide sheath for introducing, deploying, and stabilizing diagnostic or therapeutic probes in selected regions of the heart.

20 One method that embodies the invention slides a catheter body through the interior bore of a guide sheath. The catheter body has a distal tip that can be deflected for the purpose of steering the catheter body into the selected heart region through an access vein or artery. Once the catheter body is located within the selected heart region, the method slides the guide sheath over the catheter body through the access vein or artery and into the selected heart region. Next, the method withdraws the catheter body from the guide sheath bore.

25 According to this aspect of the invention, the method slides an electrode-carrying probe through the guide sheath bore. This advances the probe through the access vein or artery and into the selected heart region. The electrode can now be deployed within the selected heart region for the desired diagnostic or therapeutic purpose.

30

35

- 6 -

In a preferred embodiment, the guide sheath is moved relative to the probe to enclose the distal tip of the probe within the distal end of the guide sheath. In this embodiment, to deploy the electrode, the guide sheath is again moved relative to the probe, once positioned within the heart region, to uncover the distal tip of the probe.

Another aspect of the invention provides a catheter system and methodology that use a guide sheath to position an electrode-carrying catheter inside a selected heart region. According to this aspect of the invention, the guide sheath has a body made of a material having an elastic memory. The elastic memory of the guide sheath causes it to assume a predetermined curvature inside the heart region. The curvature maintains the distal end of the guide sheath in a desired general orientation with respect to endocardial tissue in the heart region.

The system also includes a catheter body having a distal end and a proximal end. The distal end of the catheter body carries at least one electrode. The interior bore of the guide sheath carries the catheter body. When so carried, the distal, electrode-carrying end of the catheter body extends beyond the distal end of the guide sheath. The distal, electrode-carrying end of the catheter body is generally oriented with endocardial tissue by the predetermined curvature of the guide sheath.

According to this aspect of the invention, a mechanism on the proximal end of the catheter body deflects the distal end of the catheter body. In this way, the user can achieve a final orientation between the electrode and endocardial tissue while the guide sheath maintains the general orientation.

This aspect of the invention uses the pre-

- 7 -

formed guide sheath to provide general steering guidance for advancing the electrode-carrying catheter body into the heart chamber. By establishing a general orientation with endocardial tissue, the sheath simplifies the task of finally aligning and positioning the electrode with respect to particular targeted site. The physician can accomplish these tasks using a few, relatively fine remote steering adjustments.

Yet another aspect of the invention provides a catheter system and methodology for deploying electrode-carrying catheter bodies within the heart employing a guide sheath. According to this aspect of the invention, the guide sheath includes a mechanism for deflecting its distal end to steer its advancement into the heart. The steerable guide sheath carries the catheter body, which is itself directed by the interior bore of the guide sheath into the heart.

In the preferred embodiments of all aspects of the invention, the guide sheath includes a hemostatic valve on its proximal end. The hemostatic valve blocks the outflow of fluid from the interior bore during the first and second modes of use.

In this embodiment, the hemostatic valve yields to receive the body of the electrode-carrying catheter into the interior bore while continuing to block the outflow of fluid from the interior bore. In this arrangement, the electrode-carrying catheter preferably includes a hemostat sheath. The hemostat sheath moves along the catheter body between a first position spaced from the distal tip and a second position enclosing the distal tip. By enclosing the distal tip, the

homostat sheath protects the electrode from damage during passage through the hemostatic valve.

In one preferred arrangement, the electrode carried by the catheter is operative for sensing electrical activity in endocardial tissue. In this arrangement, the catheter preferably carries a three dimensional array of multiple sensing electrodes.

The electrode can also be operative for emitting energy to ablate myocardial tissue.

Other features and advantages of the inventions are set forth in the following Description and Drawings, as well as in the appended Claims.

Brief Description of the Drawings

Fig. 1 is a side view, with portions fragmented and in section, of an endocardial mapping system that embodies the features of the invention, shown deployed and ready for use inside a heart chamber;

Fig. 2 is a side view of endocardial mapping system shown in Fig. 1, with portions fragmented and in section, showing the electrode-carrying basket in a collapsed condition before deployment inside the heart chamber;

Fig. 3 is an enlarged side view of the electrode-carrying basket and movable guide sheath shown in Fig. 2, with portions fragmented and in section, showing the electrode-carrying basket in a collapsed condition before deployment;

Fig. 4 is an enlarged side view of the electrode-carrying basket and movable guide sheath shown in Fig. 1, with portions fragmented and in section, showing the electrode-carrying basket in a deployed condition;

Fig. 5 is a side view of two splines of the basket, when deployed, showing the arrangement of

electrodes on the splines;

Fig. 6 is a section view taken generally along line 6-6 in Fig. 1, showing the interior of the catheter body for the mapping probe;

5 Fig. 7 is a plan view, with portions fragmented, of the introducer and outer guide sheath being introduced into the vein or artery access site in the process of forming the system shown in Fig. 1;

10 Fig. 8 is a plan view of the introducer, the outer guide sheath, and the steerable catheter being introduced into the access site in the process of forming the system shown in Fig. 1;

15 Fig. 9 is a plan view of the interior of the handle for the steerable catheter, partially broken away and in section, showing the mechanism for steering the distal tip of the catheter body;

20 Fig. 10 is a side view, with portions fragmented and in section, of advancing the steerable catheter body into the desired heart chamber;

Fig. 10A is a plan view of the interior of the hemostatic valve that systems embodying features of the invention use, showing the resilient slotted membrane present within the valve;

25 Fig. 11 is a side view, with portions fragmented and in section, of advancing the guide sheath along the steerable catheter body into the desired heart region;

30 Fig. 12 is a side view, with portions fragmented and in section, of the mapping probe just before being introduced for advancement within the outer guide sheath, with the hemostat sheath fully forward to enclose the electrode-carrying basket;

35 Fig. 13 is a side view, with portions fragmented and in section, of the mapping probe be-

ing advanced through the hemostatic valve of the outer guide sheath, with the hemostat sheath fully forward to enclose the electrode-carrying basket;

5 Fig. 14 is a side view, with portions fragmented and in section, of the mapping probe after advancement through the hemostatic valve of the outer guide sheath, with the hemostat sheath pulled back to uncover the electrode-carrying basket;

10 Fig. 15 is an enlarged view, with portions in section, of the electrode-carrying basket deployed inside the heart chamber in use in association with a separate ablation probe;

15 Fig. 16 is an enlarged plan view of an alternative three dimensional structure, partially in section, that can be deployed using the system shown in Fig. 1, in use in association with a separate ablation probe;

20 Fig. 17 is an enlarged side section view of the structure shown in Fig. 16 in a collapsed condition before deployment;

Fig. 18 is an enlarged plan view of an alternative three dimensional structure that can be deployed using the system shown in Fig. 1, in use in association with a separate ablation probe;

25 Fig. 19 is an enlarged side section view of the structure shown in Fig. 18 in a collapsed condition before deployment;

30 Fig. 20 is a perspective view, partially fragmented, of an alternative embodiment of an outer guide sheath having a preformed complex curvature;

Fig. 21 is an enlarged plan view, partially in section, of the guide sheath shown in Fig. 20 deployed inside the heart chamber and in use in association with a separate steerable ablation probe;

35 Fig. 22 is a perspective view, partially

- 11 -

fragmented, of an alternative embodiment of an outer guide sheath having a steerable distal tip;

5 Fig. 23 is an enlarged plan view, partially in section, of the guide sheath shown in Fig. 22 deployed inside the heart chamber and in use in association with a separate ablation probe;

10 Fig. 24 is a plan view, with portions fragmented and in section, of an integrated mapping and ablation system that embodies the features of the invention;

Figs. 25 and 26 are enlarged side elevation views of the electrode-carrying basket of the mapping probe that the system shown in Fig. 24 uses, showing the range of movement of the steerable ablating element carried within the basket;

15 Fig. 27 is a diagrammatic view of the integrated mapping and ablation system shown in Fig. 24;

20 Fig. 28 is an end elevation view, taken generally along line 28-28 in Fig. 26, of the electrode-carrying basket of the mapping probe that the system shown in Fig. 24 uses, showing the range of movement of the steerable ablating element carried within the basket;

25 Fig. 29 is an enlarged side section view of the distal end of the electrode-carrying basket of the mapping probe that the system shown in Fig. 24 uses, showing the basket in a collapsed condition about the steerable ablating element before deployment;

30 Fig. 30 is an end section view of the collapsed basket, taken generally along line 30-30 in Fig. 29;

35 Fig. 31 is a side section view of the multiple layer catheter body of the mapping probe used

in the system shown in Fig. 24;

Fig. 32 is a perspective view of the multiple layers of the catheter body shown in section in Fig., 31;

5 Fig. 33 is a view, partially in section, showing the formation of the first layer of the multiple layer catheter body shown in Figs. 31 and 32;

10 Fig. 34 is a view, partially in section, showing the formation of the second layer of the multiple layer catheter body shown in Figs. 31 and 32;

15 Fig. 35 is a view showing the formation of the third layer of the multiple layer catheter body shown in Figs. 31 and 32;

Fig. 36 is a view showing the formation of the fourth layer of the multiple layer catheter body shown in Figs. 31 and 32; and

20 Figs. 37 and 38 are views showing the formation of the fifth and final layer of the multiple layer catheter body shown in Figs. 31 and 32.

Description of the Preferred Embodiments

Fig. 1 shows an endocardial mapping system 10 that embodies features of the invention, when deployed and ready for use within a selected region 12 inside the heart.

25 The Figures generally show the selected region 12 to be the left ventricle of the heart. However, it should be noted that the heart shown in the Figures is not anatomically accurate. The Figures show the heart in diagrammatic form to demonstrate the features of the invention.

30 When deployed, the system 10 includes an introducer 14, an outer guide sheath 16, and a mapping probe 18.

35

- 13 -

As Fig. 1 shows, the introducer 14 establishes access to a vein or artery. The outer guide sheath 16 enters the access through the introducer 14. The guide sheath 16 extends through the vein or artery to enter the selected heart chamber 12.

Together, the introducer 14 and the outer sheath 16 establish a passageway that guides the mapping probe 18 through the access vein or artery and into the selected heart chamber 12.

The mapping probe 18 has a handle 20 (which Fig. 12 shows in its entirety), an attached flexible catheter body 22, and a movable hemostat sheath 30 with associated carriage 52.

The distal end of the catheter body 22 carries a three dimensional structure 24. In Fig. 1, the structure 24 takes the form of a basket. Figs. 16 and 18 show alternative structures, which will be described in greater detail later.

The three dimensional structure of the basket 24 includes an exterior surface 27 that encloses an open interior area 25. The basket 24 carries a three dimensional array of electrodes 26 on its exterior surface 27 (see Fig. 4 also).

As Fig. 1 shows, when deployed inside the heart chamber 12, the exterior surface 27 of the basket 24 holds the electrodes 26 against the endocardial surface.

When fully deployed, the outer guide sheath 16 holds the catheter body 22. The sheath 16 is made from an inert plastic material. In the preferred embodiment, the sheath 16 is made from a nylon composite material.

The sheath 16 has an inner diameter that is greater than the outer diameter of the catheter body 22. As a result, the sheath 16 can slide along the

catheter body 22.

The proximal end of the sheath 16 includes a handle 17. The handle 17 helps the user slide the sheath 16 along the catheter body 22, as the arrows in Figs. 1 and 2 depict. Figs. 1 and 2 show the range of sheath movement.

As Figs. 2 and 3 show, forward movement of the handle 17 (i.e., toward the introducer 14) advances the distal end of the slidable sheath 16 upon the basket 24. The slidable sheath 16 captures and collapses the basket 24 (as Fig. 3 also shows in greater detail). In this position, the distal end of the sheath 16 entirely encloses the basket 24.

As Figs. 1 and 4 show, rearward movement of the handle 17 (i.e., away from the introducer 14) retracts the slidable sheath 16 away from the basket 24. This removes the compression force. The basket 24 opens to assume a prescribed three dimensional shape.

The basket electrodes 26 record the electrical potentials in myocardial tissue. Connectors 44 on the handle 20 (see Figs. 12 and 13) attach to an external processor (not shown). The processor derives the activation times, the distribution, and the waveforms of the potentials recorded by the basket electrodes 26.

The basket 24 can be variously constructed. In the illustrated and preferred embodiment (best shown by Fig. 4), the basket 24 comprises a base member 32 and an end cap 34. Generally flexible splines 36 extend in a circumferentially spaced relationship between the base member 32 and the end cap 34.

In the illustrated embodiment, eight splines 36 form the basket 24. However, additional

- 15 -

or fewer splines 36 could be used, depending upon application.

In this arrangement, the splines 36 are made of a resilient inert material, like Nitinol metal or silicone rubber. The splines 36 are connected between the base member 32 and the end cap 34 in a resilient, pretensed condition.

The resilient splines 36 bend and conform to the tissue surface they contact. As Figs. 2 and 3 show, the splines 36 also collapse into a closed, compact bundle in response to an external compression force.

In the illustrated embodiment (as Figs. 4 and 5 best show), each spline 36 carries eight electrodes 26. Of course, additional or fewer electrodes 26 can be used. Furthermore, one or more electrodes 26 can also be located on the end cap 34.

The electrodes 26 can be arranged in thirty-two bi-polar pairs, or as sixty-four uni-polar elements. In the preferred embodiment, the electrodes 26 are made of platinum or gold plated stainless steel.

A signal wire 38 made from a highly conductive metal, like copper, leads from each electrode 26. The signal wires 38 extend down the associated spline 36, by the base member 32, and into the catheter body 22. An inert plastic sheath 40 preferably covers each spline 36 to enclose the signal wires 38 (see Figs. 4 and 5). In the preferred embodiment, the sheath 40 is made of polyurethane material.

The eight signal wires 38 for each spline 36 are twisted together to form a common bundle 42. As Fig. 6 shows, the eight common bundle 42 are, in turn, passed through the catheter body 22 of the

- 16 -

mapping probe 18. The common bundles 42 extend within catheter body 22 and into the probe handle 20.

5 The sixty-four signal wires 38 are distributed within the probe handle 20 to one or more external connectors 44, as Fig. 12 shows. In the illustrated embodiment, each connector contains thirty-two pins to service thirty-two signal wires. The connectors 44 attach to the external processor.

10 As Fig. 6 shows, the catheter body 22 also includes an inner sleeve that forms a central lumen 46. The wire bundles 42 are oriented in an equally spaced array about this lumen 46. In the preferred embodiment, the sleeve of the central lumen 46 is made of a Teflon material.

15 The proximal end of the central lumen 46 is attached to a flushing port 48 that extends outside the handle 20, as Fig. 12 shows. The distal end of the central lumen 46 opens at the base member 32 of the basket 24. Anticoagulant or saline can be introduced through the flushing port 48 into the heart chamber 12 that the basket 24 occupies.

20 In the illustrated and preferred embodiment (as Fig. 5 best shows), a first region 54 on the proximal end of each spline 36 is free of electrodes 26. Likewise, a second region 56 on the distal end of each spline 36 is also free of electrodes 26. These two fore and aft regions 54 and 56 generally fail to make stable surface contact with the endocardial tissue. Therefore, electrodes 26 in these regions may not uniformly provide reliable signals.

30 The eight electrodes 26 on each spline 36 are arranged in 4 groups of equally spaced pairs in a third region 58 between the two end regions 54 and 35 56. The third region 58 uniformly makes stable sur-

- 17 -

face contact with the endocardial tissue, creating reliable signals from the electrodes 26.

Figs. 7 to 14 show the details of introducing the system 10 into the heart chamber 12.

5 The system 10 includes a steerable catheter 60 (see Fig. 8) to facilitate the introduction and positioning of the outer guide sheath 16.

10 The catheter 60 directs the introduction of the outer guide sheath 16, which is otherwise free of any onboard steering mechanism. The guide sheath 16, in turn, directs the introduction of the mapping probe 18, which is likewise free of any onboard steering mechanism.

15 Use of a separate catheter 60 for steering purposes results in a significant reduction in the overall size of the system components.

20 If the mapping probe 18 carried its own onboard steering mechanism, the catheter body 22 would have to be of sufficient size to accommodate it. Typically, this would require a catheter body 22 with a diameter of about 12-14 French (one French is 0.33 mm in diameter).

25 Furthermore, if carried onboard the mapping probe 18, the steering mechanism would also have to be of sufficient strength to deflect the entire structure of the basket 24 when in a collapsed condition.

30 According to this aspect of the invention, use of a separate, dedicated steerable catheter 60 permits the introduction of the entire system 10 through the access vessel and into the heart chamber using an outer guide sheath of about only 10 French. The catheter body 22 of the mapping probe 18 can also be significantly smaller, being on the order of
35 6 to 8 French. In addition, a smaller steering

- 18 -

mechanism can also be used, because only the outer sheath 16 needs to be steered.

As Fig. 7 shows, the introducer 14 has a skin-piercing cannula 62. The physician uses the cannula 62 to establish percutaneous access into the selected vein or artery (which is typically the femoral vein or artery). The other end of the introducer 14 includes a conventional hemostatic valve 64.

The valve 64 includes a resilient slotted membrane 65 (as Fig 10A shows). The slotted membrane 65 blocks the outflow of blood and other fluids from the access. The slot in the membrane 65 yields to permit the introduction of the outer guide sheath 16 through it. The resilient membrane 65 conforms about the outer surface of the sheath 16, thereby maintaining a fluid tight seal.

The introducer 14 also includes a flushing port 66 for introducing anticoagulant or other fluid at the access site.

As Fig. 8 shows, the steerable catheter 60 includes a catheter body 68 having a steerable tip 70 at its distal end. A handle 72 is attached to the proximal end of the catheter body 68. The handle 12 encloses a steering mechanism 74 for the distal tip 70.

The steering mechanism 74 can vary. In the illustrated embodiment (see Fig. 9), the steering mechanism is the one shown in Copending U.S. Application Serial No. 07/789,260, which is incorporated by reference.

As Fig. 9 shows, the steering mechanism 74 of this construction includes a rotating cam wheel 76 within the handle 72. An external steering lever 78 rotates the cam wheel. The cam wheel 76 holds the

- 19 -

proximal ends of right and left steering wires 80.

The steering wires 80 extend along the associated left and right side surfaces of the cam wheel 76 and through the catheter body 68. The steering wires 80 connect to the left and right sides of a resilient bendable wire or spring (not shown) that deflects the steerable distal tip 70 of the catheter body 68.

As Fig. 8 shows, forward movement of the steering lever 80 bends the distal tip 70 down. Rearward movement of the steering lever 80 rearward bends the distal tip 70 up. By rotating the handle 70, thereby rotating the distal tip 70, and thereafter manipulating the steering lever 80 as required, it is possible to maneuver the distal tip 70 virtually in any direction.

In an alternative arrangement (shown in phantom line view A in Fig. 8), the steerable distal tip 70 can also be bent out of a normal coaxial relationship with the catheter body 68 using custom shaped wire stiffeners 71. The stiffeners 71 create a pre-formed, complex curve configuration. The complex curvature simplifies access to difficult-to-reach locations within the heart, such as the aortic approach through the left ventricle to the left atrium.

Figs. 10 and 11 show the details of using the steerable catheter 60 to guide the outer sheath 16 into position.

The outer guide sheath 16 includes an interior bore 82 that receives the steerable catheter body 68 of the catheter 60. The physician can slide the outer guide sheath 16 along the steerable body 68 of the catheter 60.

- 20 -

The handle 17 of the outer sheath 16 includes a conventional hemostatic valve 84. The valve 84, like the valve 64, includes a resilient slotted membrane 65 (as Fig. 10A shows) that blocks the out-flow of blood and other fluids. Like the valve 64, the slotted membrane 65 yields to permit the introduction of the body 22 of the mapping probe 18 through it. At the same time, the membrane 65 conforms about the outer surface of the body 22 to maintain a fluid tight seal.

Together, the valves 64 and 84 provide an effective hemostatic system that allows a procedure to be performed in a clean and relatively bloodless manner.

In use, the steerable catheter body 68 enters the bore 82 of the guide sheath 16 through the valve 84, as Fig. 10 shows. The handle 17 of the outer sheath 16 also preferably includes a flushing port 28 for the introduction of an anticoagulant or saline into the interior bore 82.

As Fig. 10 also shows, the physician advances the catheter body 68 and the outer guide sheath 16 together through the access vein or artery. The physician retains the sheath handle 17 near the catheter handle 72 to keep the catheter tip 70 outside the distal end of the outer sheath 16. In this way, the physician can operate the steering lever 78 to remotely point and steer the distal end 70 of the catheter body 68 while jointly advancing the catheter body 68 and guide sheath 16 through the access vein or artery.

The physician can observe the progress of the catheter body 68 using fluoroscopic or ultrasound imaging, or the like. The outer sheath 16 can include an radio-opaque compound, such a barium, for

- 21 -

this purpose. Alternatively, a radio-opaque marker can be placed at the distal end of the outer sheath 16.

5 This allows the physician to maneuver the catheter body 68 through the vein or artery into the selected interior heart chamber 12, as Fig. 10 shows.

10 As Fig. 11 shows, when the physician locates the distal end 70 of the catheter body 68 in the desired endocardial chamber 12, he/she slides the outer sheath handle 17 forward along the catheter body 68, away from the handle 72 and toward the introducer 14. The catheter body 68 directs the guide sheath 16 fully into the heart chamber 12, 15 coextensive with the distal tip 70.

Holding the handle 17 of the outer sheath 16, the physician withdraws the steerable catheter body 68 from the outer guide sheath 16.

20 The system 10 is now deployed in the condition generally shown in Fig. 12. As Fig. 12 shows, the guide sheath bore 82 establishes a passageway that leads directly from the introducer 14 into the selected heart chamber 12. The mapping probe 18 follows this passageway for deployment inside the chamber 12. 25

As Fig. 12 shows, before introducing the mapping probe 18, the physician advances the hemostat sheath 30, by pushing on the carriage 52. The sheath 30 captures and collapses the basket 24.

30 As Fig. 13 shows, the physician introduces the hemostat sheath 30, with enclosed basket 24, through the hemostatic valve 84 of the outer sheath handle 17. The hemostat sheath 30 protects the basket electrodes 26 from damage during insertion 35 through the valve 84.

- 22 -

As Fig. 14 shows, when the catheter body 22 is advanced approximately three inches into the guide sheath 16, the physician pulls back on the sheath carriage 52 to withdraw the hemostat sheath 30 from the valve 84. The hemostat valve 84 seals about the catheter body 22. The guide sheath 16 now itself encloses the collapsed basket 24.

As Fig. 2 shows, the outer sheath 16 directs the basket 24 of mapping probe 18 to the desired location inside the heart chamber 12. As Fig. 1 shows, the physician then moves the handle 17 rearward. The distal end of the sheath 16 slides back to deploy the basket 24 for use.

Once deployed, the physician can again collapse the basket 24 (by pushing forward on the handle 17), as Fig. 2 shows. The physician can then rotate the sheath 16 and probe 18 to change the angular orientation of the basket electrodes 26 inside the chamber 12, without contacting and perhaps damaging endocardial tissue. The physician can then redeploy the basket 24 in its new orientation by pulling back on the handle 17, as Fig. 1 shows.

The physician analyses the signals received from the basket electrodes 26 to locate likely efficacious sites for ablation.

The physician can now takes steps to ablate the myocardial tissue areas located by the basket electrodes 26. The physician can accomplish this result by using an electrode to thermally destroy myocardial tissue, either by heating or cooling the tissue. Alternatively, the physician can inject a chemical substance that destroys myocardial tissue. The physician can use other means for destroying myocardial tissue as well.

The illustrated and preferred embodiment

- 23 -

accomplishes ablation by using an endocardial electrode to emit energy that heats myocardial tissue to thermally destroy it. The energy is transmitted between the endocardial electrode and an exterior
5 indifferent electrode on the patient.

The type of ablating energy can vary. It can, for example, be radio frequency energy or microwave energy. The ablating energy heats and thermally destroys the tissue to form a lesion,
10 thereby restoring normal heart rhythm.

Ablating energy can be conveyed to one or more electrodes 26 carried by the basket 24. In this way, one or more of the sensing electrodes 26 on the basket 24 can also be used for tissue abla-
15 tion.

As Fig. 15 shows, an external steerable ablating probe 150 can be used in association with the basket 24. The physician steers the probe 150 under fluoroscopic control to maneuver the ablating
20 element 152 into the basket 24. Once inside the basket 24, the physician steers the ablating element 152 into contact with the tissue region identified by the basket electrodes 26 as the likely efficacious site for ablation. The physician then conveys
25 ablating energy to the element 152.

In this arrangement, the basket 24 serves, not only to identify the likely ablation sites, but also to stabilize the external ablating probe 150 within a confined region within the heart chamber
30 12.

Figs. 16 and 17 show an alternative configuration for a three dimensional structure 154 that the mapping probe 18 can carry.

In this embodiment, the structure 154 comprises a single length of inert wire material, such
35

- 24 -

a Nitinol metal wire, preformed into a helical array. While the particular shape of the helical array can vary, in the illustrated embodiment, the array has a larger diameter in its midsection than on its proximal and distal ends.

As Fig. 16 shows, the structure 154 can be used to stabilize the external steerable ablation probe 150 in the same fashion as the basket 24 shown in Fig. 15 does.

The structure 154 can also carry electrodes 156, like the basket 24, for mapping and/or ablating purposes.

As Fig. 17 shows, the structure 154 can be collapsed in response to an external compression force. The distal end of the slidable guide sheath 16 provides this compression force to retract and deploy the structure 154 inside the selected heart chamber, just like the basket structure 24.

Figs. 18 and 19 show yet another alternative configuration for a three dimensional structure 158 that can be carried by the mapping probe 18. In this embodiment, the structure 158 comprises two independent loops 160 and 162 of inert wire material, such a Nitinol metal wire.

The loop 160 nests within the loop 162. The distal ends of the nested loops 160 and 162 are not joined. Instead, the nested loops 160 and 162 are free to flex and bend independently of each other.

In the illustrated configuration, the loops 160 and 162 form right angles to each other. Of course, other angular relationships can be used. Additional independent loops can also be included to form the structure 158.

As Fig. 18 shows, the loop structure 158

- 25 -

can be used to stabilize the external steerable ablation probe 150 in the same fashion as the structures 24 and 154 shown in Figs. 15 and 16 do.

5 One or more of the loops 160 and 162 can also carry electrodes 164 for mapping and/or ablating purposes.

10 As the previous structures 24 and 154, the structure 158 can be collapsed in response to an external compression force, as Fig. 19 shows. The distal end of the slidable guide sheath 16 provides this compression force to retract and deploy the structure 158 inside the selected heart chamber 12.

15 Figs. 20 and 21 show an alternative embodiment of a guide sheath 166 that can be used in association with the introducer 14 to locate a steerable ablation probe 168 inside the selected heart chamber 12.

20 Unlike the guide sheath 22, the guide sheath 166 is preformed with a memory that assumes a prescribed complex curvature in the absence of an external stretching or compressing force.

25 Fig. 20 shows in phantom lines the guide sheath 166 in a stretched or compressed condition, as it would be when being advanced along the steerable catheter body 68 through the access vein or artery.

30 Upon entering the less constricted space of the heart chamber 12, as Fig. 21 shows, the sheath 166 assumes its complex curved condition. The complex curve is selected to simplify access to difficult-to-reach locations within the heart, such as through the inferior vena cava into the right ventricle, as Fig. 21 shows.

35 Like the sheath 16, the sheath 166 preferably includes a conventional hemostatic valve 169 on

- 26 -

its proximal end. As previously described, the hemostatic valve 169 includes a resilient slotted membrane to block the outflow of fluids, while allowing passage of a catheter body.

5 Fig. 21 shows the sheath 166 in use in association with a steerable ablating probe 168, which enters the sheath 166 through the hemostatic valve 169. The sheath 166, like the sheath 16, guides the probe 168 through the access vein or artery into the heart chamber 12.

10 The complex curvature of the sheath 166 more precisely orients the steerable ablation probe 168 with respect to the intended ablation site than the sheath 16. As Fig. 21 shows, the complex curvature points the distal end of the sheath 166 in a general orientation toward the intended ablation site. This allows the physician to finally orient the ablating element 170 with the intended site using fine steering adjustments under fluoroscopic control.

20 The embodiment shown in Figs. 20 and 21 uses the preformed sheath 166 to provide relatively coarse steering guidance for the ablation probe 168 into the heart chamber 12. The sheath 166 simplifies the task of final alignment and positioning of the ablating element with respect to the precise ablation region, which the physician can accomplish using a few, relatively fine remote steering adjustments.

30 Figs. 22 and 23 show yet another alternative embodiment of a guide sheath 172 that can be used in association with the introducer 14 to locate an ablation probe 174 inside the selected heart chamber 12.

35 In Figs. 22 and 23, the guide sheath 172

- 27 -

includes a sheath body 176 with a steerable distal tip 178. As Fig. 22 shows, the sheath body 176 is extruded to include a center guide lumen 180 and two side lumens 182. Steering wires 183 extend through the side lumens 182, which are located near the exterior surface of the body 176.

The distal ends of the steering wires 183 are attached to the side lumens 182 at the distal tip 178 of the sheath body 176. The proximal ends of the steering wires 183 are attached to a steering mechanism 186 within a handle 188 attached at the proximal end of the sheath body 176.

The steering mechanism 186 can vary. In the illustrated embodiment, the mechanism 186 is the rotating cam arrangement shown in Fig. 9. In this arrangement, the steering mechanism 186 includes an exterior steering lever 190. Fore and aft movement of the steering lever 190 deflects the distal tip 178 of the guide sheath 176, as Fig. 22 shows.

Like the sheath 16, the sheath 172 preferably includes a conventional hemostatic valve 185 on its proximal end to block the outflow of fluids while allowing the passage of a catheter body.

The steerable guide sheath 172 is used in association with the introducer 14. The physician steers the guide sheath 172 through the access vein or artery and into the selected heart chamber 12 under fluoroscopic control, as Fig. 23 shows. The physician then introduces the probe 174 through the center guide lumen 180.

In this arrangement, the probe 174 can carry a mapping structure, like those shown in Figs. 1; 16; and 18. Alternatively (as Fig. 23 shows), the probe 174 carries an ablating element 192.

Because the guide sheath 174 is itself

- 28 -

steerable, the catheter body 194 of the probe 174 need not include a steering mechanism. The catheter body 194 need only carry the electrical conduction wires its function requires. The catheter body
5 194 can therefore be downsized. Alternatively, the absence of a steering mechanism frees space within the catheter body 194 for additional or larger electrical conduction wires, as ablating elements using coaxial cable or temperature sensing elements
10 may require.

Fig. 24 shows an integrated system 86 for performing endocardial mapping and ablation.

Like the first described system 10, the integrated system 86 includes a mapping probe 18 with sensing electrodes 26 carried by a three dimensional
15 basket 24. In addition, the integrated system 86 includes, as an integral part, a steerable ablating element 88 that is carried within the open interior area 25 of the basket 24.

The ablating element 88 can be moved relative to the sensing electrodes 26 in three principal directions. First, the ablating element 88 moves along the axis of the mapping probe body 96. Second, the ablating element 88 moves rotationally
20 about the axis of the mapping probe body 96. Third, the ablating element 88 moves in a direction normal to the axis of the mapping probe body 96. Figs. 25 to 28 show the range of movement the preferred embodiment provides.

Movement of the ablating element 88 does not effect the contact between the sensing electrodes 26 and the endocardial tissue. In other words, the electrodes 26 and the ablating element 88 are capable of making contact with endocardial tissue
30 independent of each other.
35

- 29 -

More specifically, the system 86 includes a steerable ablation catheter 90 that is an integral part of the mapping probe 18. The ablation catheter 90 includes a steering assembly 92 with a steerable distal tip 84. The steerable distal tip 84 carries the ablating element 88.

As Fig. 27 shows diagrammatically, the mapping probe 18 includes a catheter body 96 through which the steering assembly 92 of the ablation catheter 90 passes during use. The proximal end of the catheter body 96 communicates with an opening at the rear of the handle 20. The distal end of the catheter body 96 opens into the interior area 25 of the basket 24. A conventional hemostatic valve 95 is located at this junction. As previously described, the valve 95 includes a resilient slotted membrane that blocks the outflow of fluid while allowing the passage of the steering assembly 92.

The proximal end of the steering assembly 92 of the ablation catheter 90 is attached to a handle 98 (as Fig. 24 best shows). By pulling and pushing the handle 98, the physician moves the ablating element 88 along the axis of the mapping probe body 96. By rotating the handle 98, the physician rotates the ablating element 88 about the axis of the mapping probe body 96.

The handle 98 further encloses a steering mechanism 74 for the tip 84. The steering mechanism 74 for the ablating catheter 90 is the same as the steering mechanism 74 for the catheter 60 used in the first described system 10, and thereby shares the same reference number.

As Fig. 27 generally shows, movement of the steering lever 78 forward bends the distal tip 84, and with it, the ablating element 88, down. Move-

- 30 -

ment of the steering lever 78 rearward bends the distal tip 84, and with it, the ablating element 88, up.

5 Figs. 25 and 26 also show the movement of the distal tip 84 and element 88 through the basket 24 between a generally straight configuration (Fig. 25) and a deflected position, placing the ablating element 88 in contact with endocardial tissue (Fig. 26).

10 By coordinating lateral (i.e., pushing and pulling) movement of the handle 98 with handle rotation and tip deflection, it is possible to move the ablating element 88 in virtually any direction normal to the axis of the catheter body 96, as Fig. 28 shows.

15 By rotating and moving the handle 98 in these ways, it is possible to maneuver the ablating element 88 under fluoroscopic control through the basket 24 into contact with any point of the endocardial surface of the chamber 12. The ablating element 88 can be moved through the basket 24 to tissue locations either in contact with the exterior surface of the basket 24 or laying outside the reach of the basket 24 itself.

25 A cable 100 with an outer insulating sheath is attached to the ablating element 88 (see Figs. 27 and 29). The electrically insulated cable 100 extends down the length of the steering assembly 92. The cable 100 conveys ablating energy to the element 88.

30 A plug 102 attached to the proximal end of the cable 100 (see Figs. 24 and 27) extends outside the handle 98 for connection to a source of ablating energy (not shown).

35 The integrated mapping and ablation system

- 31 -

86 shown in Fig. 24 shares various other components and methodologies with the first described system 10. Elements shared by the two embodiments are given common reference numbers.

5 The integrated system 86 uses the same introducer 14 to establish an access. It also uses the same outer guide sheath 16 and the same steerable catheter 60 (with steerable catheter body 68) to position the outer guide sheath 16. The outer
10 sheath 16 is inserted through the introducer 14 and positioned inside the heart by the steerable catheter body 68 in the same fashion as earlier described (and as shown in Figs. 10 and 11).

 As also earlier described (and as Fig. 2 shows), the mapping probe 18 is guided by the outer sheath 16 into position. The mapping probe 18 in
15 the integrated system 86 also includes the slidable sheath 16 to enclose and deploy the basket 24, in the same manner as earlier described. When enclosed by the sheath 16, the basket 24 collapses about the
20 distal tip 94 and ablating element 88 (as Figs. 29 and 30 show).

 In use, the physician guides the mapping probe 18 with integral ablating catheter 90 into
25 position through the outer sheath 16. The physician then deploys the basket 24, freeing the ablating element 88 for use, as Fig. 24 shows.

 As Fig. 24 shows, the basket structure contacts the surrounding endocardial tissue to hold and
30 stabilize the ablating element 88 in a desired confined region within the heart while the basket electrodes 26 provide mapping signals. The ablating element 88 can be remotely steered to sites identified by the basket electrodes 26 (as Fig. 26
35 shows). Ablating energy can then be applied to

- 32 -

thermally destroy the tissue.

As in the first described embodiment, the basket electrodes 26 can be used for ablation purposes, too.

5 As Figs. 31 and 32 show, the catheter body 96 of the mapping probe 18 comprises an integral multiple layer structure. In this structure, the signal wires 38 for the sensing electrodes 26 on the basket 24 are imbedded within the walls of the
10 catheter body 96. This structure frees space at the interior of catheter body 96 to accommodate passage of the steering assembly 92.

As Figs. 31 and 32 show, the catheter body 96 includes a center tube 106 made from a plastic
15 material, such as Pebax tubing. The center tube 106 has an interior bore 108 of a size that accommodates the steering assembly 92 of the ablating catheter 90.

The catheter body 96 includes two layers
20 110 and 112 of copper signal wire 38 (42 gauge) wrapped about the center tube 106. Each copper signal wire 38 carries an outer insulating sheath. In addition, the two layers 110 and 112 are separated from each other by an insulation layer 114 of Teflon
25 plastic or the like. The layer 114 provides an added measure of insulation between the wires 38, particularly in regions where point contact between the overlapping wire layers 110 and 112 could occur.

In the illustrated embodiment, where the
30 basket 24 has sixty-four electrodes, each layer 110 and 112 carries eight groups of four signal wires 38. The signal wires 38 are preferably wound helically along the length of the catheter body 96.

The catheter body 96 further includes a
35 metalized plastic layer 116 (such as metalized

- 33 -

polyimid) that surrounds the second layer 112 of signal wires 38. The layer 116 protection against electromagnetic interference (EMI). The layer 116 is, in turn, enclosed within an outer plastic tube 118 of a material such as Pebax.

Figs. 33 to 38 show a process for making the multiple layer catheter body 96.

As Fig. 33 shows, the center tube 106 is fastened by clamps 124 to a mandrel 126. The mandrel 126 is rotated during the assembly process. In the illustrated embodiment, the mandrel 126 rotates in a clockwise direction.

A wire holder 128 dispenses thirty-two shielded signal wires 38 in eight groups of four each. During the assembly process, the holder 128 advances along the axis of the mandrel 126 upon a rotating lead screw 130. In the illustrated embodiment, the lead screw 130 is rotated clockwise to advance the holder 128 from left to right along the axis of the rotating mandrel 126.

By synchronizing the rotation of the mandrel 126 with the translation of the holder 128, the wire groups dispensed by the holder 128 are helically wrapped about the center tube 106. This forms the first layer 110 of signal wires 38 about the center tube 106.

As Fig. 34 shows, another holder 132 is advanced by the lead screw 130 along the axis of the rotating mandrel 126. The holder 132 helically wraps insulating Teflon plastic tape 134 about the first layer 110 of signal wires 38. This forms the added insulating layer 114 of the catheter body 96.

As Fig. 35 shows, the wire holder 128 is again advanced by the lead screw 130 along the axis of the rotating mandrel 126, which during this step

is rotated counterclockwise. The holder 128 dispenses thirty-two additional signal wires 38 in eight groups of four each about the insulating layer 114. The rotating lead screw 130 advances the holder 128
5 from right to left while the mandrel 126 rotates counterclockwise to helically wrap the second layer 112 of signal wires 38 about the insulating layer 114, counterwound to the first layer 110.

The counterwinding of the signal wire layers 110 and 112 provides greater torque transmission for rotating the basket 24 in response to rotating the handle 20. While counterwinding is preferred for this reason, the signal wire layers 110 and 112 can be wrapped in the same direction.
10

As Fig. 36 shows, another holder 136 is advanced by the lead screw 130 along the axis of the rotating mandrel 126. The holder 136 helically wraps metalized plastic material 138 about the second wire layer 112, creating the EMI shield layer 116.
15
20

As Fig. 37 shows, another holder 140 advanced by the lead screw 130 dispenses adhesive 142 upon the metalized layer 116.

As Fig. 38 shows, the outer sleeve 118 is pulled over the adhesive 142 to complete the structure of the multiple layer catheter body 96.
25

Various features of the invention are set forth in the following claims.

- 35 -

What is claimed is:

1. A catheter system for use within the heart comprising

5 a first catheter body having a distal end and means for deflecting the distal end to steer the first catheter body into a selected heart region,

10 a second catheter body, separate from the first catheter body, having a distal end that carries at least element operative for performing a therapeutic or diagnostic function inside the heart, and

15 a guide sheath, separate from both the first and second catheter bodies, the guide sheath having an interior bore that, in a first mode of use, receives the first catheter body for advancement, guided by the first catheter body, into the selected heart region and, in a second mode of use, receives the second catheter body to guide the advancement of the second catheter body into the selected heart region for deployment of the functional element.

2. A system according to claim 1

wherein the guide sheath includes a proximal end that includes hemostatic valve means for blocking the outflow of fluid from the interior bore during the first and second modes of use.

3. A system according to claim 1

wherein the functional element is operative for sensing electrical activity in endocardial tissue.

4. A system according to claim 1

wherein the functional element is operative for ablating myocardial tissue.

5. A system according to claim 1

wherein the second catheter body includes

- 36 -

at its distal tip a three dimensional structure, and
wherein the functional element includes at
5 least one electrode carried by the three dimensional
structure.

6. A system according to claim 5
wherein the three dimensional structure
comprises a single length of wire shaped to enclose
an open interior area.

7. A system according to claim 5
wherein the three dimensional structure
comprises a single length of wire shaped as a helix
and enclosing an open interior area.

8. A system according to claim 5
wherein the three dimensional structure
comprises at least two loops that project outwardly
beyond the distal tip, with one loop nested within
5 the other loop, the loops being free of connection
at their distal ends to flex independently of each
other.

9. A system according to claim 5
wherein the three dimensional structure
defines a multiple spline basket.

10. A system according to claim 5
wherein the guide sheath includes a proxi-
mal end and a distal end, the proximal end including
a handle for moving the guide sheath along the sec-
ond catheter body between a first position, in which
the distal end of the guide sheath captures and col-
lapses the three dimensional structure, and a second
position, in which the distal end of the guide
sheath is spaced from the three dimensional struc-
ture, deploying the three dimensional structure.

11. A system according to claim 10
wherein the handle includes hemostatic
valve means for blocking the outflow of fluid from

- 37 -

the interior bore of the guide sheath during the first and second modes of use.

12. A catheter system for use within the heart comprising

5 a first catheter body having a distal end and means for deflecting the distal end to steer the first catheter body into a selected heart region,

a second catheter body, separate from the first catheter body, having a distal end that carries a three dimensional structure,

10 a third catheter body, independent of the first and second catheter bodies, the third catheter body having a distal end that carries an ablating element,

15 a guide sheath, separate from both the first and second catheter bodies, the guide sheath having an interior bore that

(i) in a first mode of use, receives the first catheter body for advancement, guided by the first catheter body, into the selected heart region;

20 (ii) in a second mode of use, receives the second catheter body to guide the advancement of the second catheter body into the selected heart region with the three dimensional structure captured and collapsed within the guide sheath; and

25 (iii) in a third mode of use, is movable away from the distal end of the second catheter body to free the three dimensional structure from the guide sheath, and

30 wherein the three dimensional structure, when free of the guide sheath, defines an open interior area that receives the distal tip of the third catheter body to stabilize the ablating element while used to ablate myocardial tissue.

- 38 -

13. A system according to claim 12 wherein the three dimensional structure comprises a single length of wire shaped to enclose an open interior area.

14. A system according to claim 12 wherein the three dimensional structure comprises a single length of wire shaped as a helix and enclosing an open interior area.

5 15. A system according to claim 12 wherein the three dimensional structure comprises at least two loops that project outwardly beyond the distal tip, with one loop nested within the other loop, the loops being free of connection at their distal ends to flex independently of each other.

16. A system according to claim 12 wherein the three dimensional structure defines a multiple spline basket.

17. A system according to claim 12 wherein the three dimensional structure carries an array of electrodes for sensing electrical activity in endocardial tissue.

5 18. A method of introducing a probe having a distal tip that carries at least one functional element into a selected region of the heart for a desired diagnostic or therapeutic purpose, the method comprising the steps of

sliding a catheter body through the interior bore of a guide sheath, the catheter body having a distal tip that can be deflected,

10 advancing the catheter body through an access vein or artery while deflecting the distal tip to direct it into the selected heart region,

sliding the guide sheath along the catheter body through the access vein or artery and into

- 39 -

the selected heart region,

15 withdrawing the catheter body from the
guide sheath bore,

 sliding the probe through the guide sheath
bore to advance the probe through the access vein or
artery and into the selected heart region, and

20 deploying the functional element within the
selected heart region for the desired diagnostic or
therapeutic purpose.

19. A method according to claim 18
wherein, after deployment, the functional
element is used for sensing electrical activity in
endocardial tissue.

20. A method according to claim 18
wherein, after deployment, the functional
element is used to ablate myocardial tissue.

5 21. A method according to claim 18
and further including the step of moving
the guide sheath relative to the probe one direction
to enclose the distal tip of the probe within the
distal end of the guide sheath, and

 wherein, in the step of deploying the
10 functional element, the guide sheath is moved in an-
other direction relative to the probe to uncover the
distal tip of the probe.

22. A catheter system for use within the
heart comprising

5 a guide sheath having a body enclosing an
interior bore with a proximal end and a distal end,
the guide sheath body being made of a material hav-
ing an elastic memory that assumes within the heart
a predetermined curvature establishing between the
distal end and endocardial tissue a desired general
orientation, and

10 a catheter body having a distal end and a

proximal end, the catheter body being removably carried within the interior bore of the guide sheath with the distal end of the catheter body extending beyond the distal end of the guide sheath and being generally oriented with endocardial tissue by the predetermined curvature of the guide sheath,

at least one element carried on the oriented distal end of the catheter body that is operative for performing a therapeutic or diagnostic function within the heart, and

means on the proximal end of the catheter body for deflecting the distal end of the catheter body to achieve a final orientation between the functional element and endocardial tissue while the guide sheath maintains the general orientation.

23. A system according to claim 22

wherein the functional element is operative for sensing electrical activity in endocardial tissue.

24. A system according to claim 22

wherein the functional element is operative for ablating myocardial tissue.

25. A system according to claim 22

wherein the guide sheath includes hemostatic valve means on its proximal end for blocking the outflow of fluid from the interior bore.

26. A method of introducing a probe into a selected region of the heart for a desired diagnostic or therapeutic purpose, the method comprising the steps of

introducing a guide sheath through an access vein or artery into the selected heart region, the guide sheath having a body enclosing an interior bore with a proximal end and a distal end, the guide sheath body being made of a material having an elas-

- 41 -

10 tic memory that, upon reaching the selected heart
region, assumes a predetermined curvature that gen-
erally orients the distal end with respect to a pre-
determined endocardial location within the region,
advancing a catheter body including a dis-
15 tal end that carries at least element that is opera-
tive for performing a therapeutic or diagnostic
function within the heart through the interior bore
of the guide sheath until the distal end of the
catheter body extends beyond the distal end of the
20 guide sheath and is, by virtue of the predetermined
curvature, generally oriented with respect to the
predetermined endocardial location, the catheter
body including a proximal end that includes steering
means for deflecting the distal tip, and
25 operating the steering means to deflect the
distal tip to achieve a final orientation between
the functional element and the endocardial tissue
while the guide sheath maintains the general orien-
tation.

27. A method according to claim 26
and further including the step of using the
functional element to sense electrical activity in
endocardial tissue.

28. A method according to claim 26
and further including the step of using the
functional element to ablate myocardial tissue.

29. A system for the deployment of a
catheter body into the heart comprising
a guide sheath having a proximal end and a
distal end, the guide sheath having an interior bore
for slidably receiving the catheter body, and
5 means on the proximal end of the guide
sheath for deflecting its distal end to steer the
guide sheath during its advancement through an ac-

- 42 -

cess vein or artery into the heart.

30. A system according to claim 29 wherein the guide sheath includes hemostatic valve means on its proximal end for blocking the outflow of fluid from the interior bore.

31. A catheter system for use within the heart comprising

a guide sheath having an interior bore with distal and proximal ends,

5 means on the proximal end of the guide sheath for deflecting its distal end of the body to steer the guide sheath during its advancement into the heart,

10 a catheter body having a distal end removably carried within and being guided by the interior bore of the guide sheath with the distal end of the catheter body extending beyond the distal end of the guide sheath into the heart, and

15 an element carried on the distal end of the catheter body that is operative for performing a therapeutic or diagnostic function within the heart.

32. A system according to claim 31

wherein the functional element is operative for sensing electrical activity in endocardial tissue.

33. A system according to claim 31

wherein the functional element is operative for ablating myocardial tissue.

34. A system according to claim 31

wherein the guide sheath includes hemostatic valve means on its proximal end for blocking the outflow of fluid from the interior bore.

35. A method of introducing a probe having a distal tip that carries at least one electrode into a selected region of the heart for a desired

5 diagnostic or therapeutic purpose, the method comprising the steps of

introducing a guide sheath through an access vein or artery into the selected heart region, the guide sheath having a body enclosing an interior bore with a proximal end and a distal end, the guide sheath body including steering means on its proximal end for deflecting its distal end,

10 advancing the guide sheath through the access vein or artery while operating the steering means to deflect the distal tip, thereby directing the guide sheath into the selected heart region,

15 advancing the probe through the interior bore of the guide sheath until its distal tip extends beyond the distal end of the guide sheath.

36. A method according to claim 35 and further including the step of using the electrode to sense electrical activity in endocardial tissue.

37. A method according to claim 35 and further including the step of using the electrode to emit energy to ablate myocardial tissue.

38. A catheter system for use within the heart comprising

a catheter including a body having a distal tip that carries at least one electrode,

5 a guide sheath, separate from the catheter body, the guide sheath having an interior bore that receives the catheter body to guide the advancement of the catheter body into the selected heart region for deployment of the electrode,

10 the guide sheath including a proximal end that includes hemostatic valve means that yields to receive the catheter body into the interior bore

while blocking the outflow of fluid from the interior bore, and

15 the catheter including a hemostat sheath movable along the body between a first position spaced from the distal tip and a second position enclosing the distal tip to protect the electrode from damage during passage of the distal tip through the hemostatic valve means.

39. A system according to claim 38

wherein the distal tip of the catheter body carries an array of electrodes.

40. A system according to claim 38

5 wherein the distal tip of the catheter body carries a three dimensional array of electrodes that assumes a collapsed condition when the hemostat sheath is in its second position enclosing the distal end.

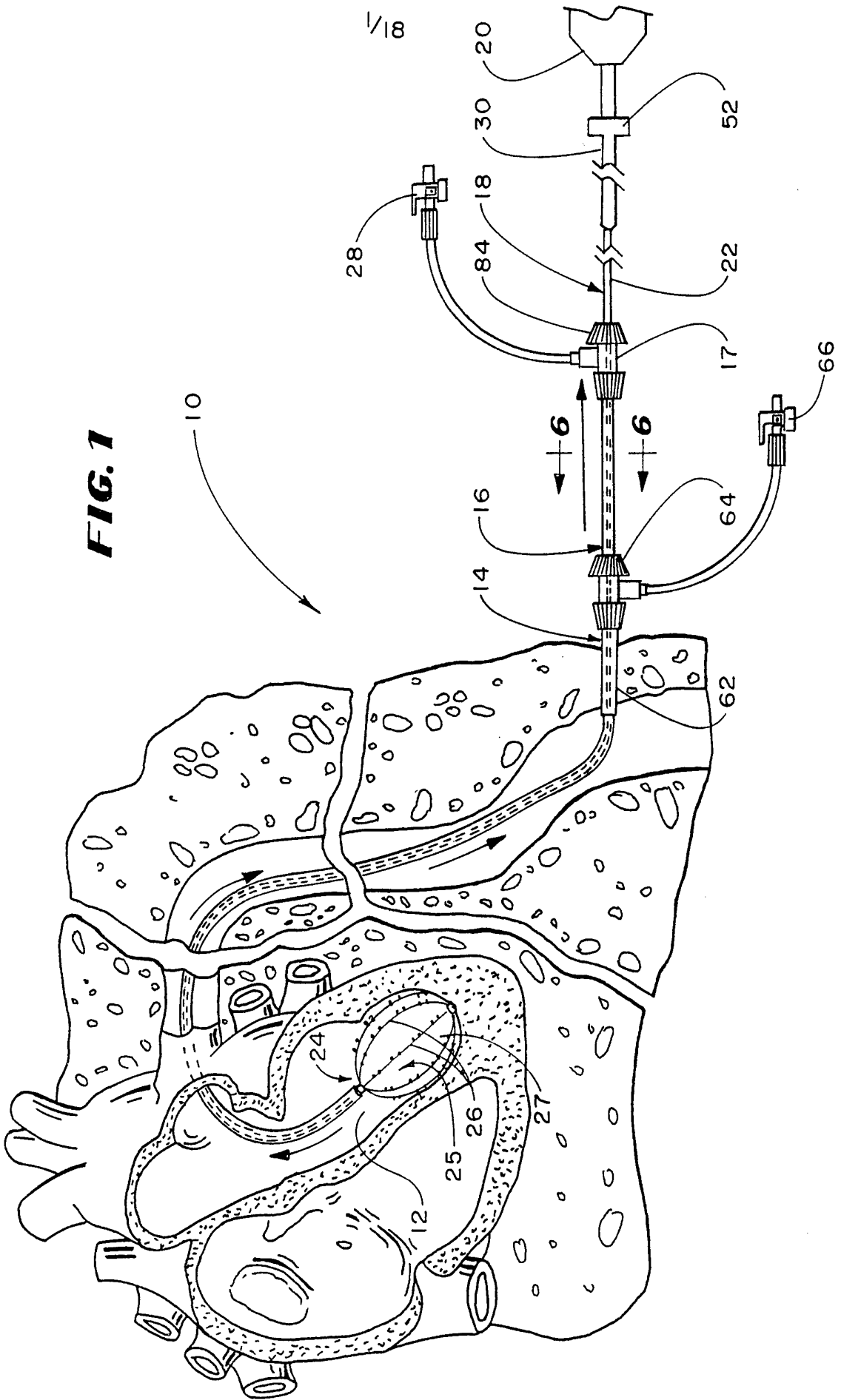

FIG. 1

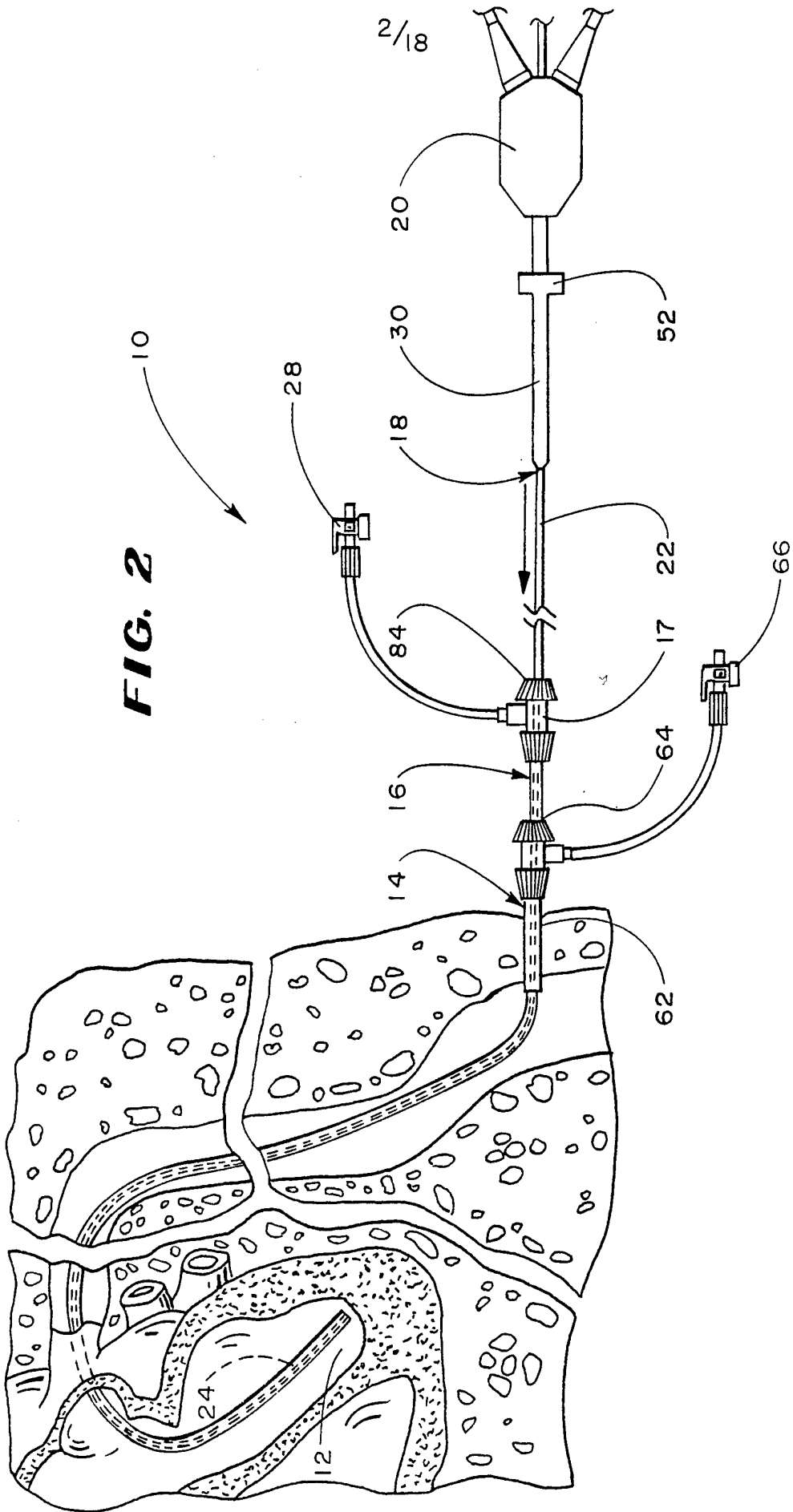

FIG. 2

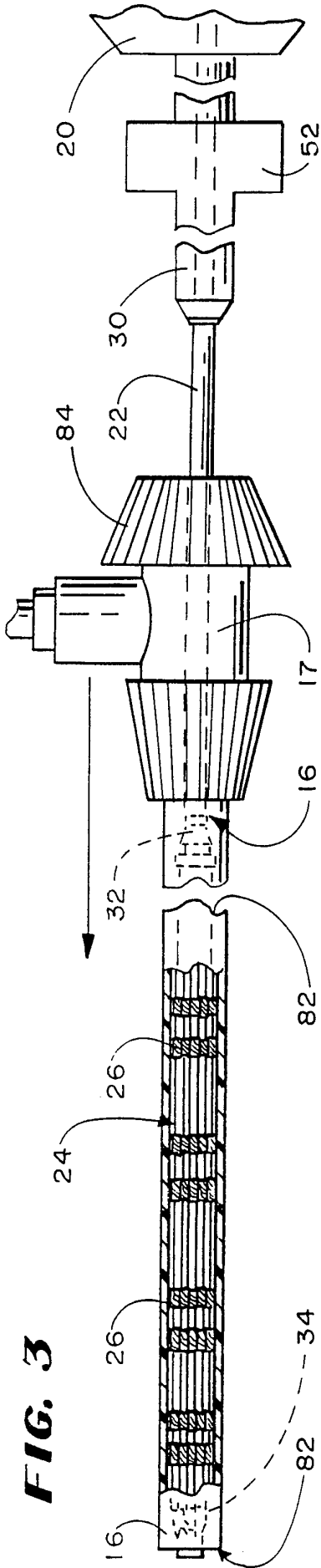

FIG. 3

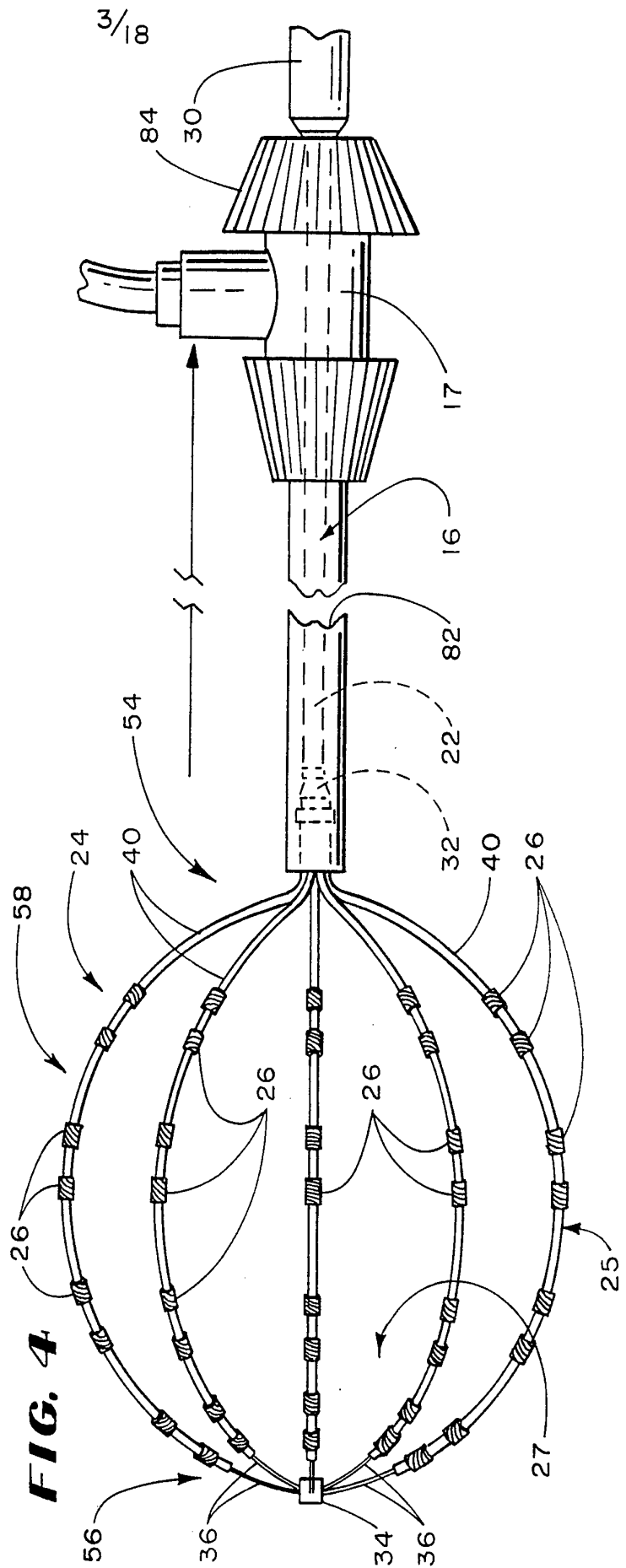

FIG. 4

4/18

FIG. 5

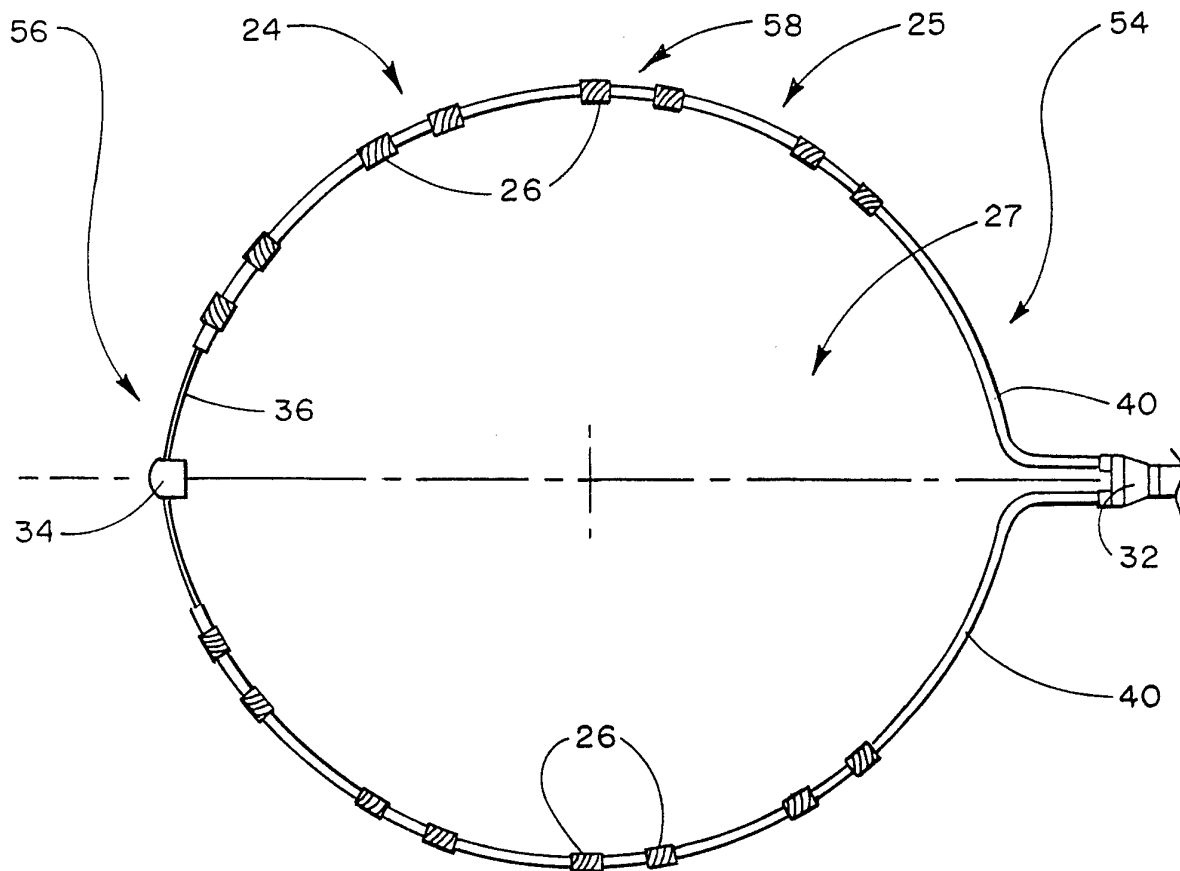
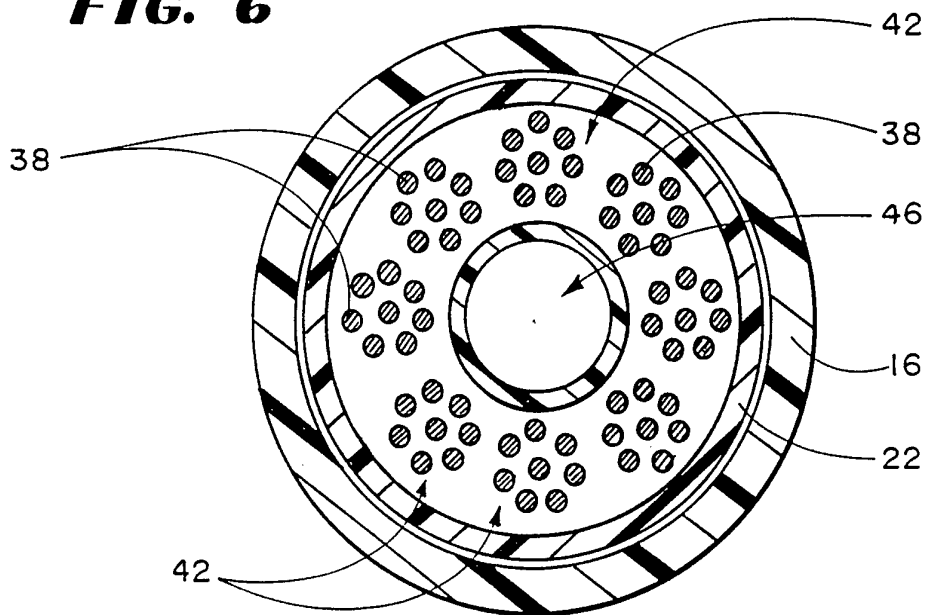

FIG. 6



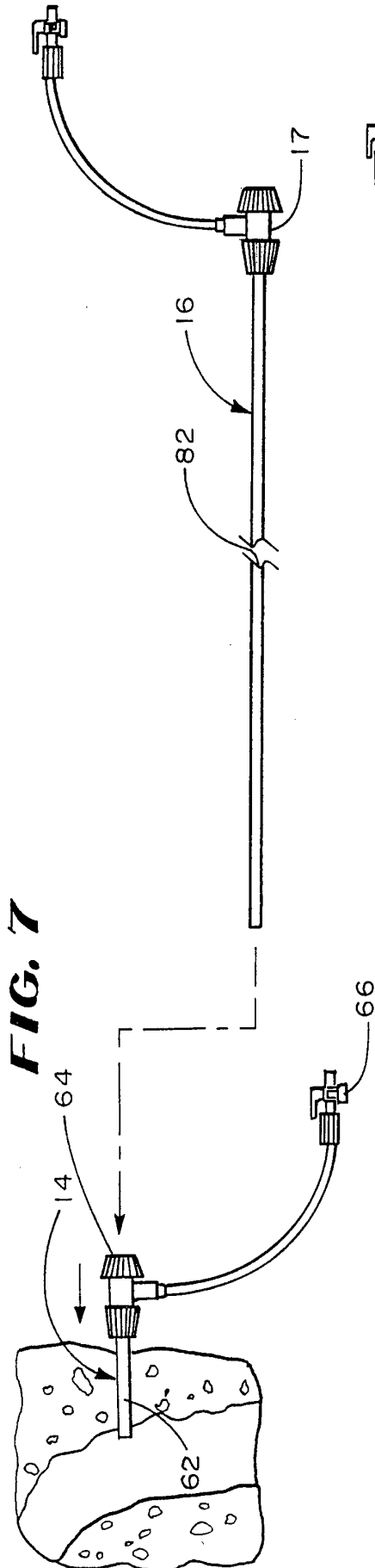

FIG. 7

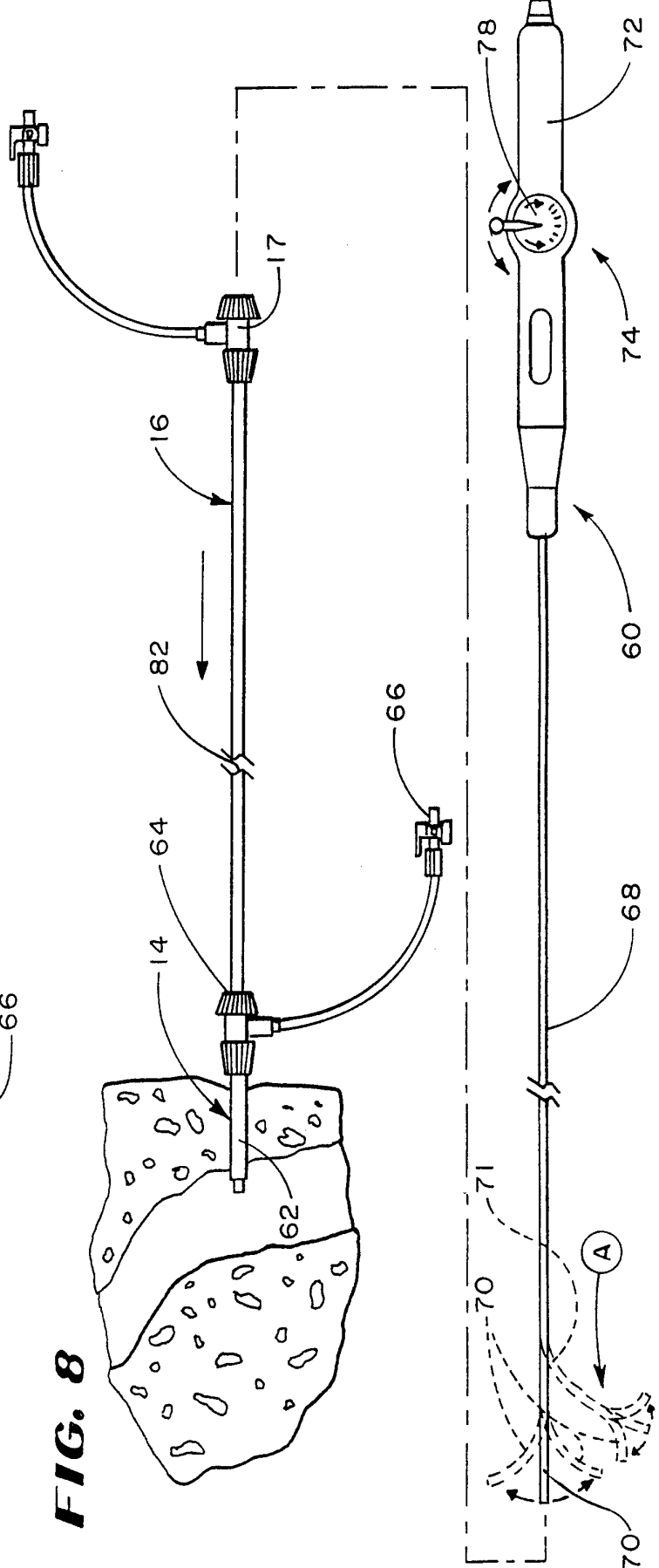

FIG. 8

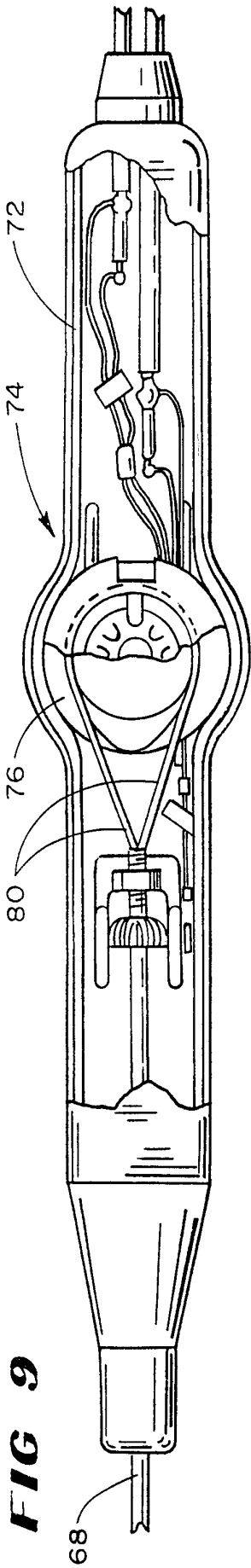

FIG 9

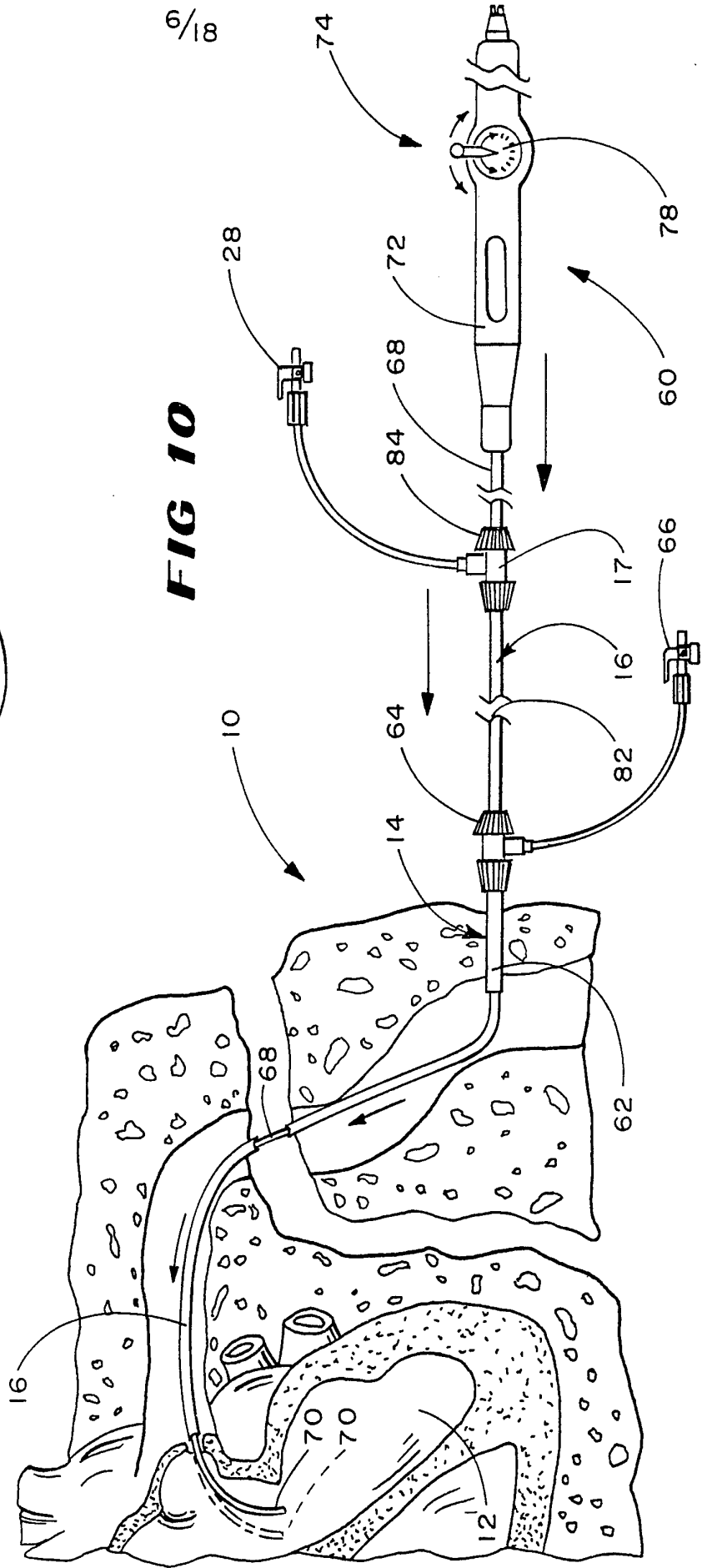
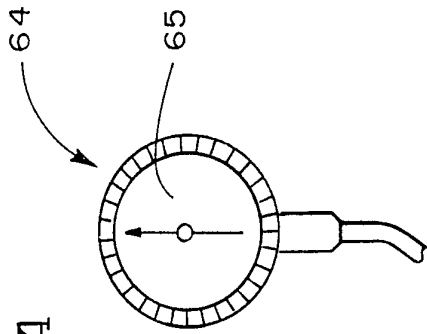

FIG 10

FIG. 10A



7/18

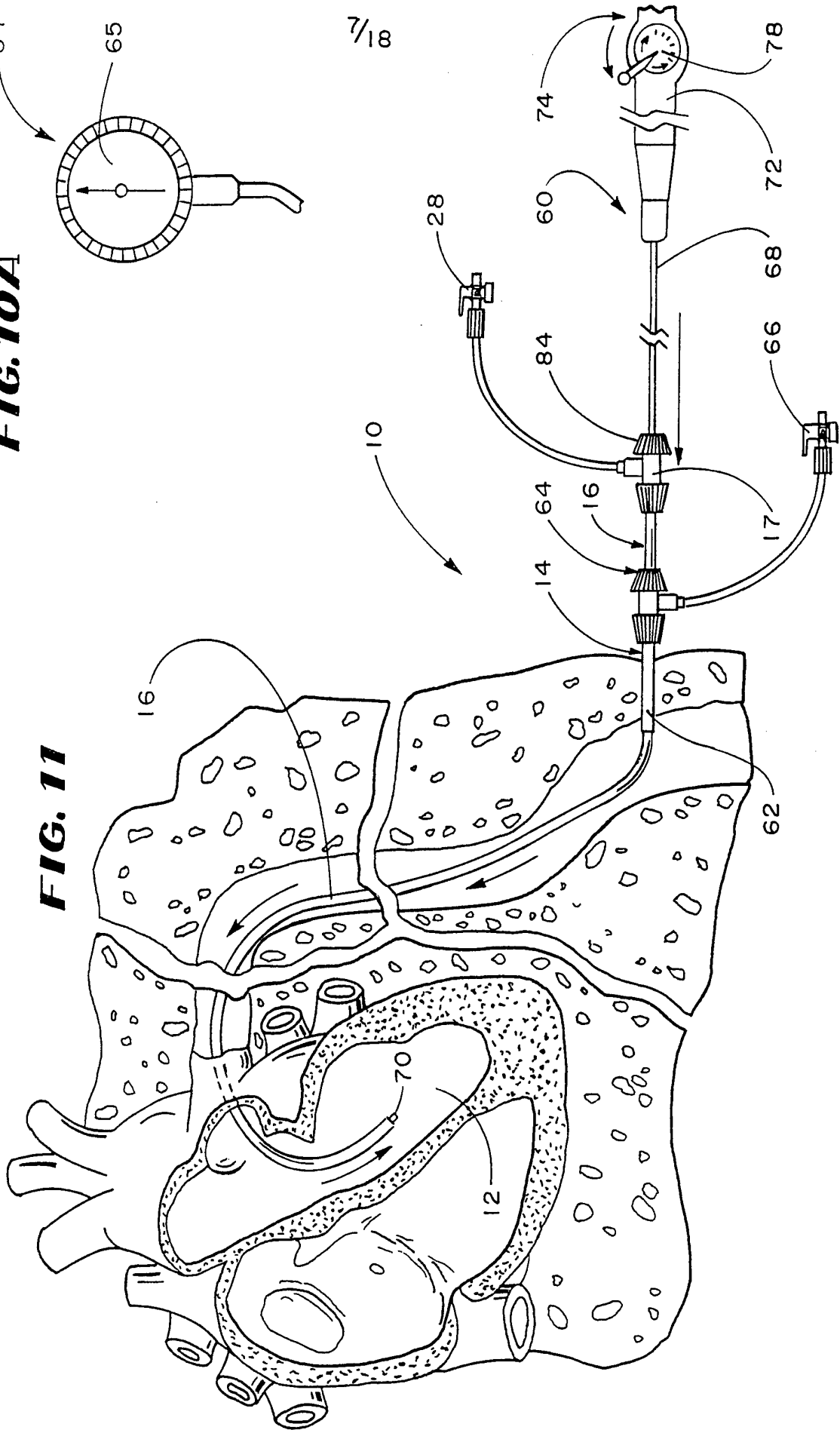
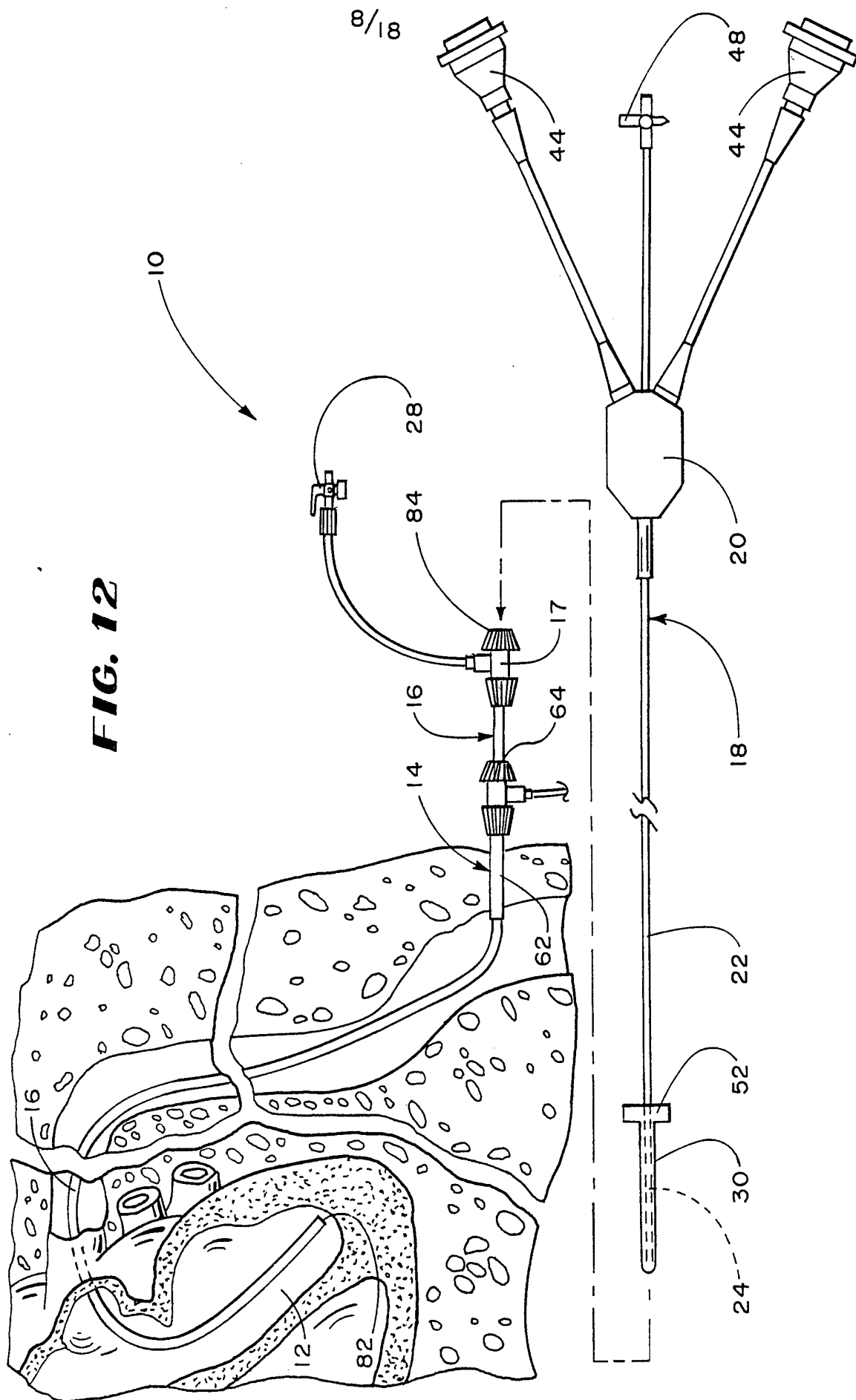

FIG. 11



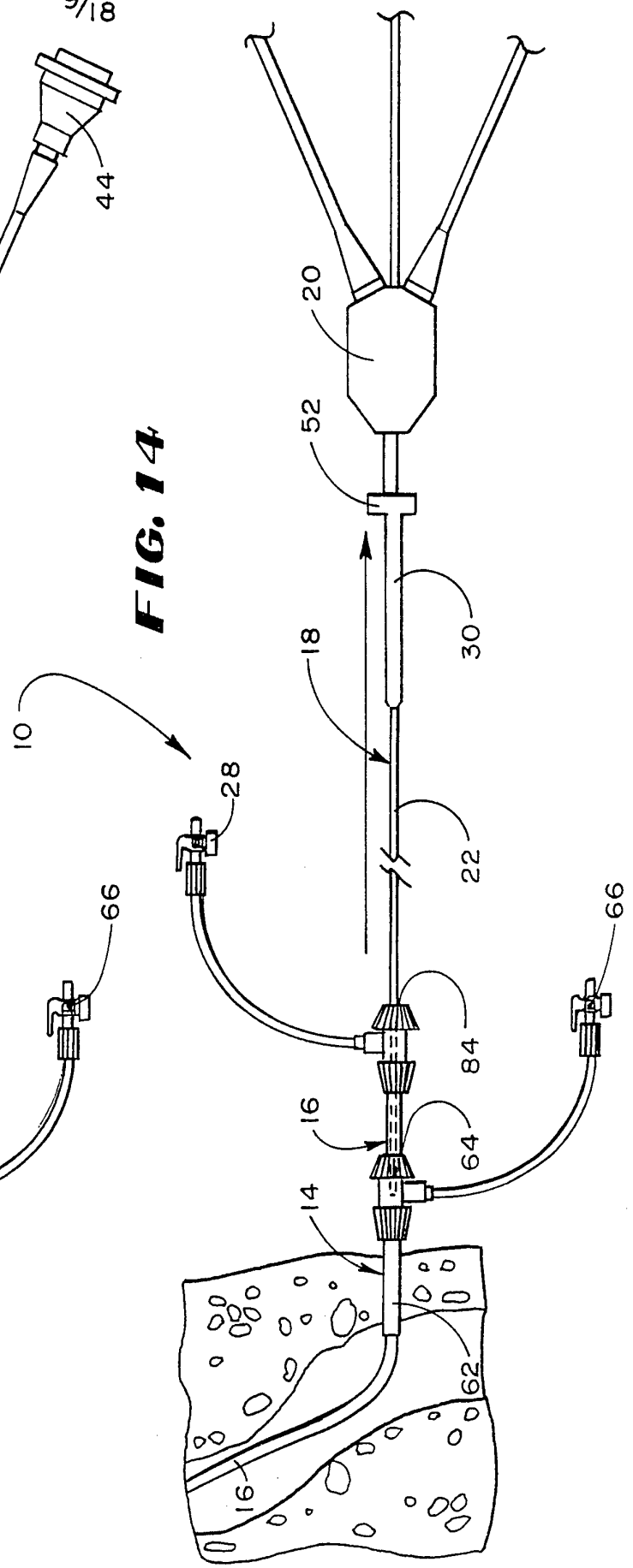
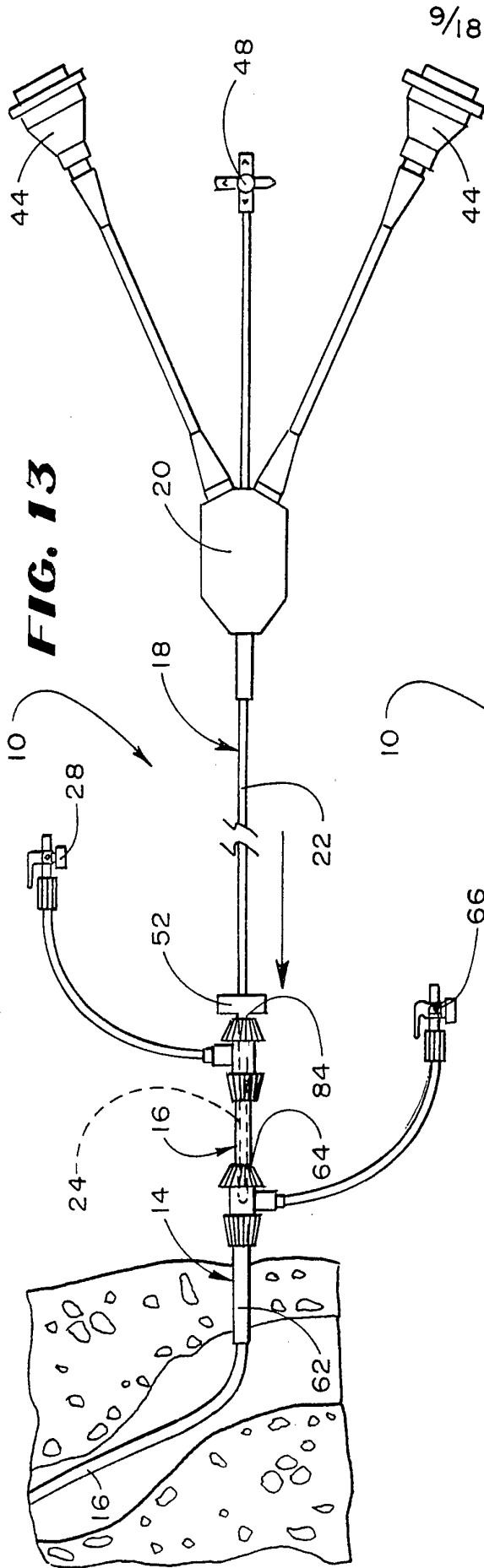

FIG. 15

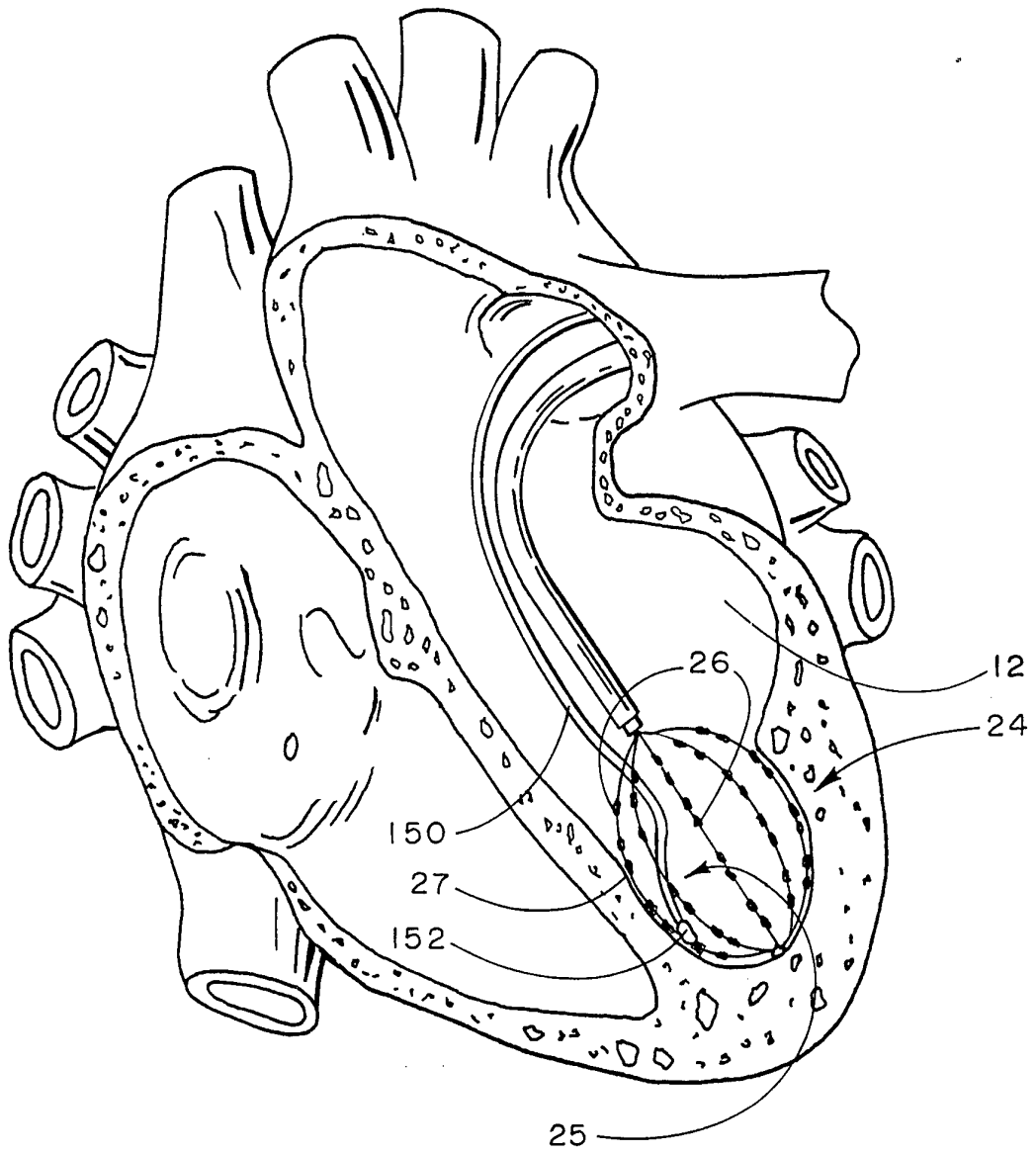
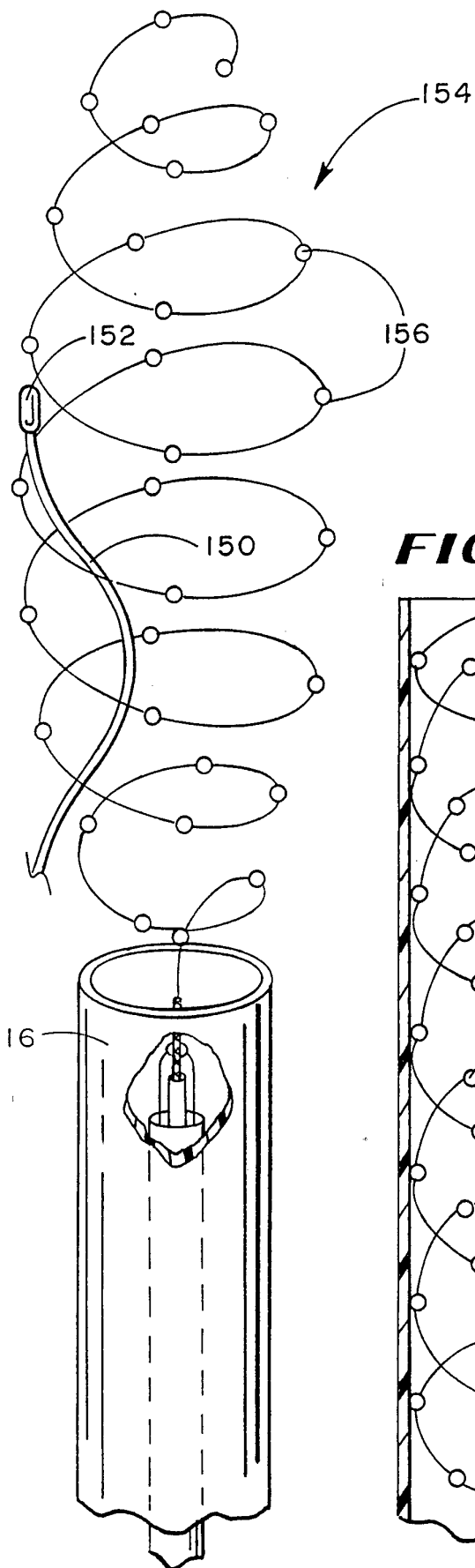

FIG. 16



11/18

FIG. 18

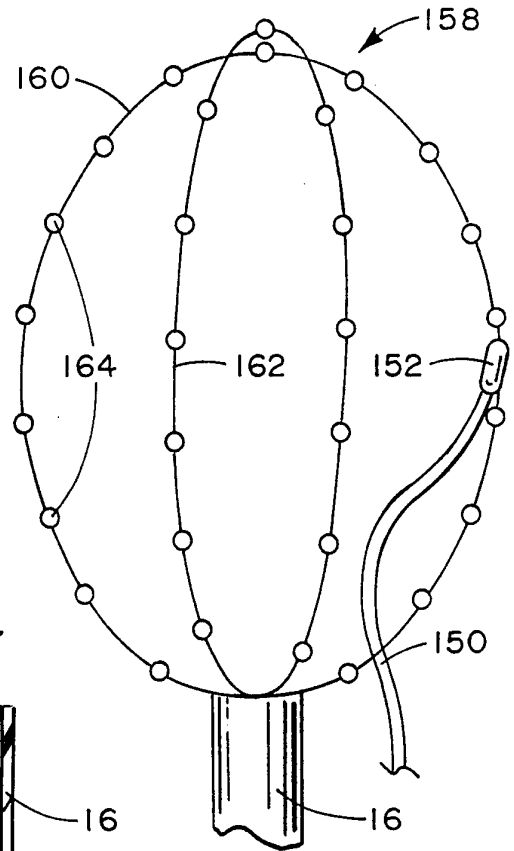

FIG. 17

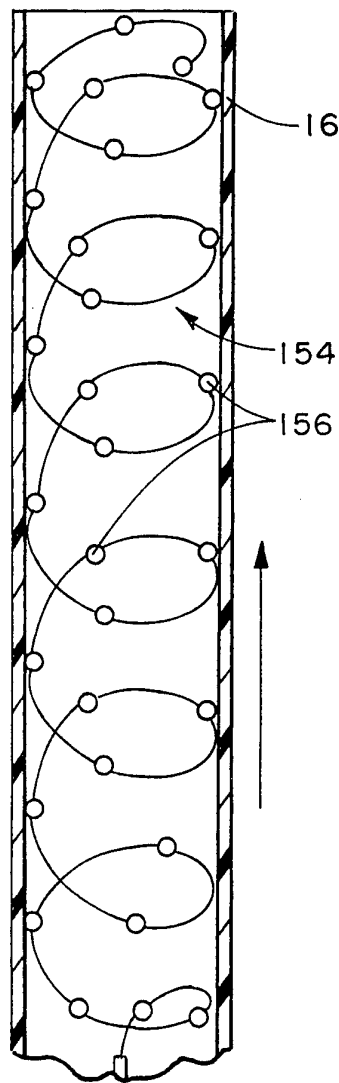
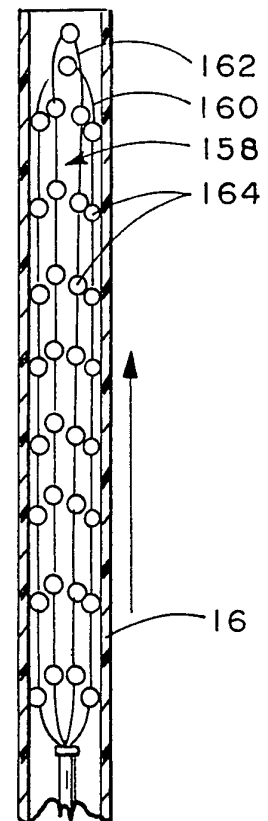

FIG. 19



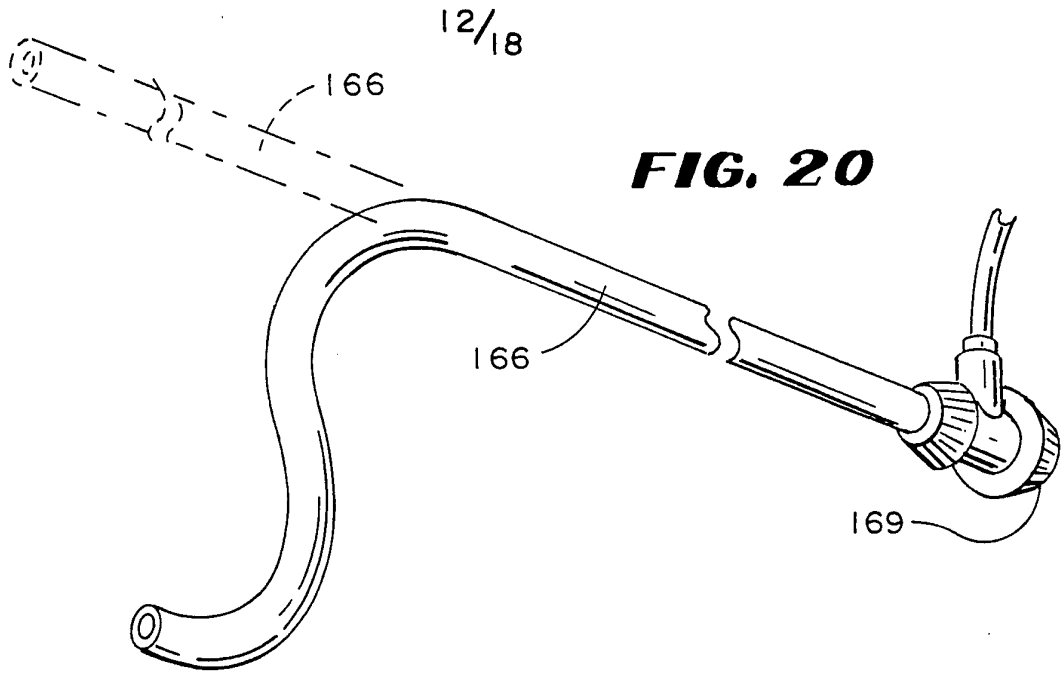

FIG. 20

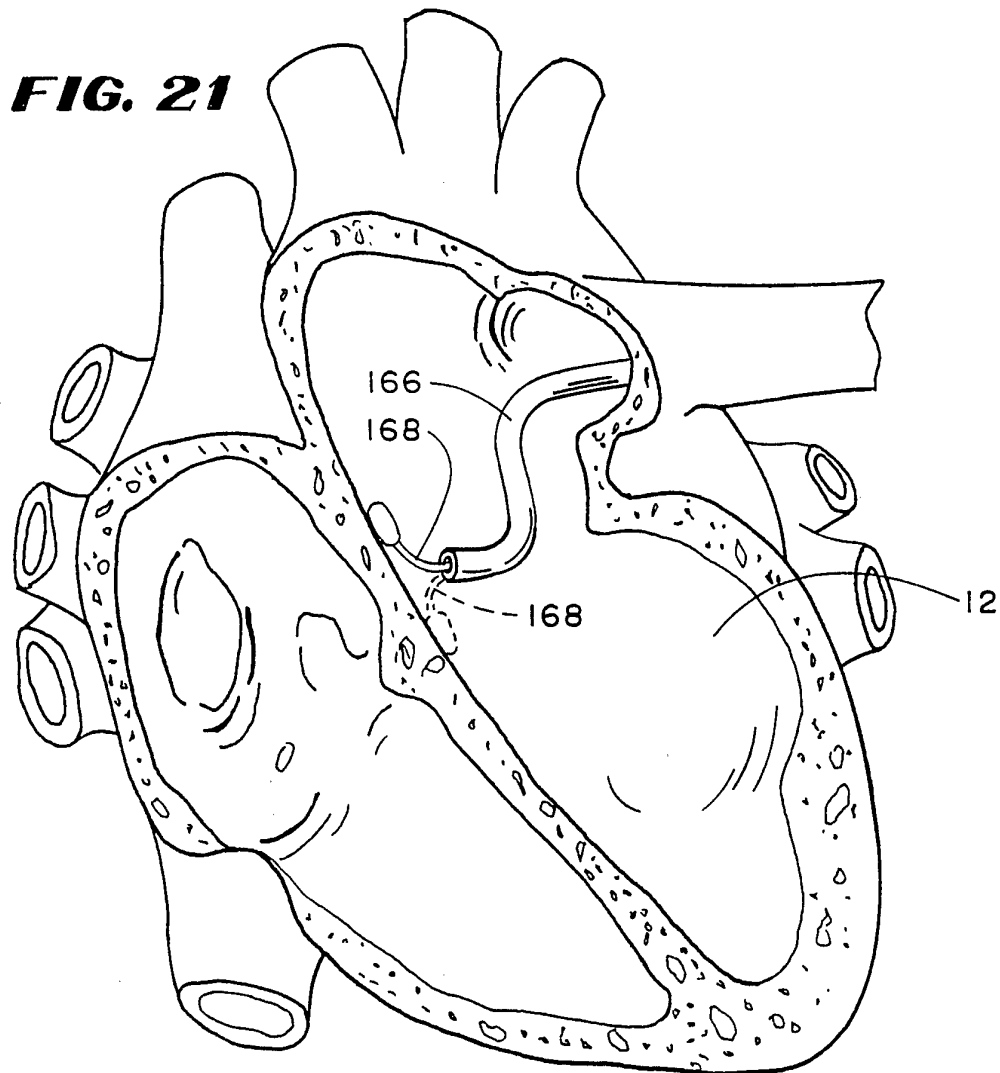

FIG. 21

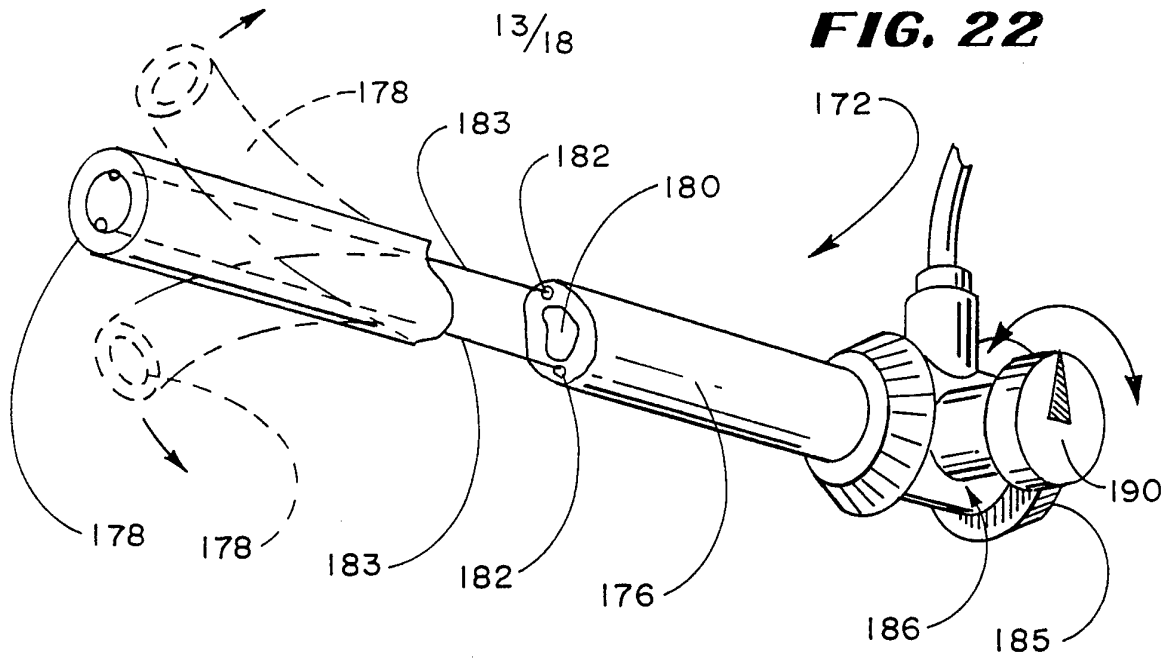
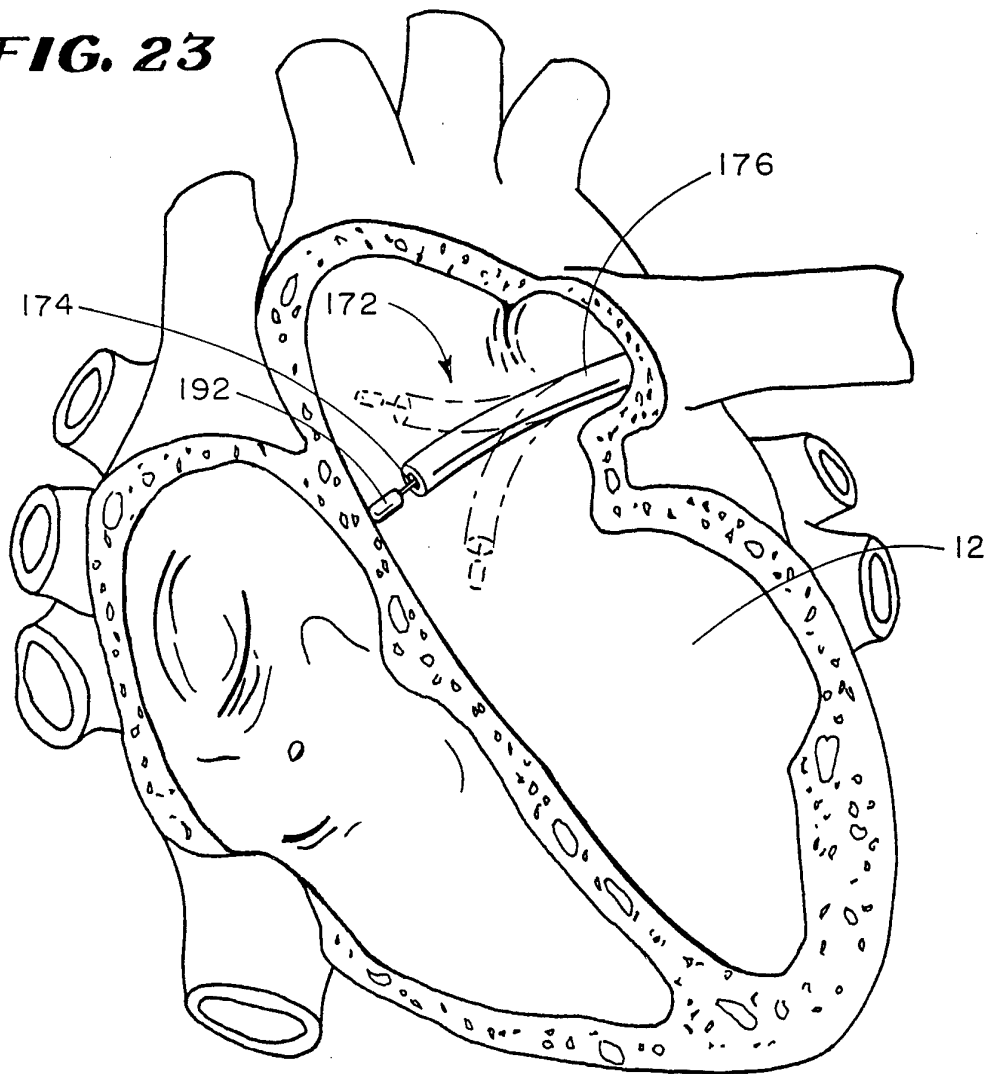

FIG. 23



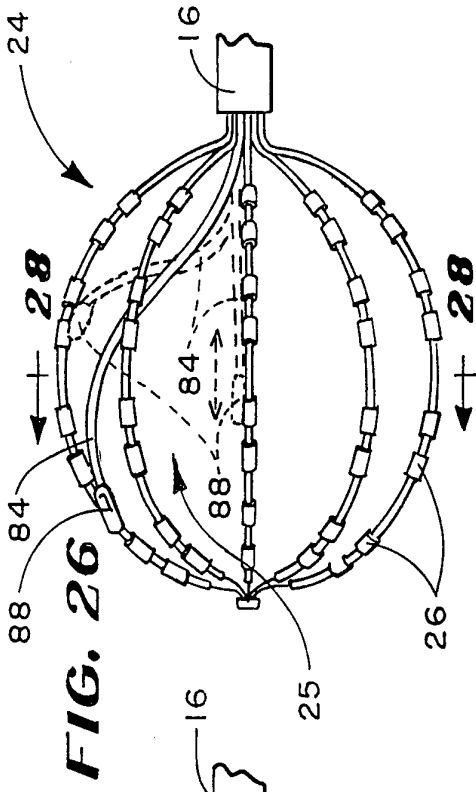

FIG. 26

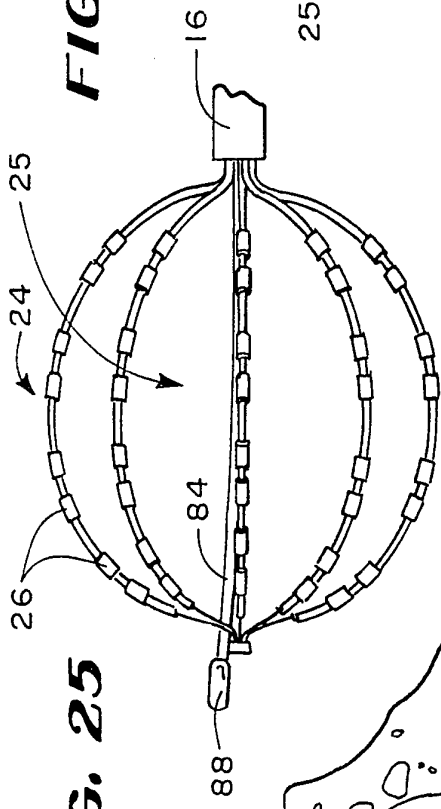

FIG. 25

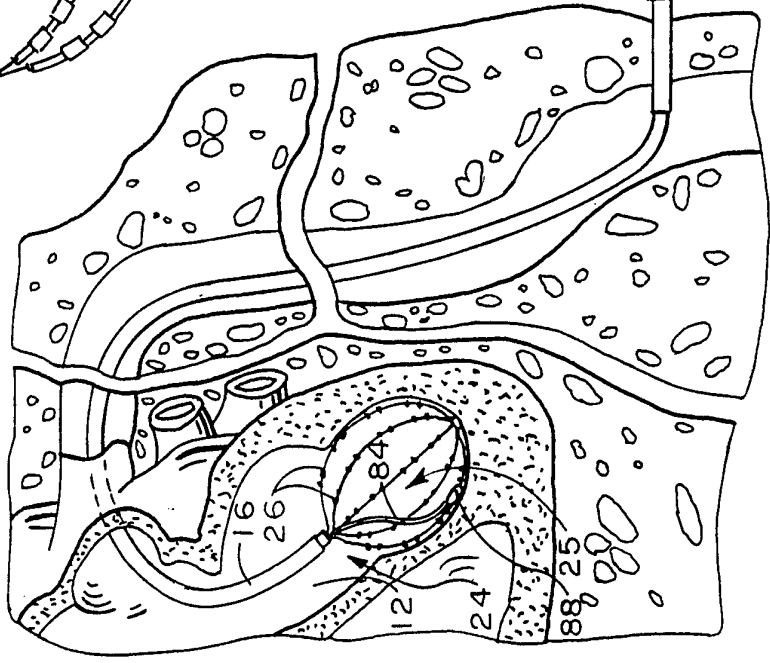
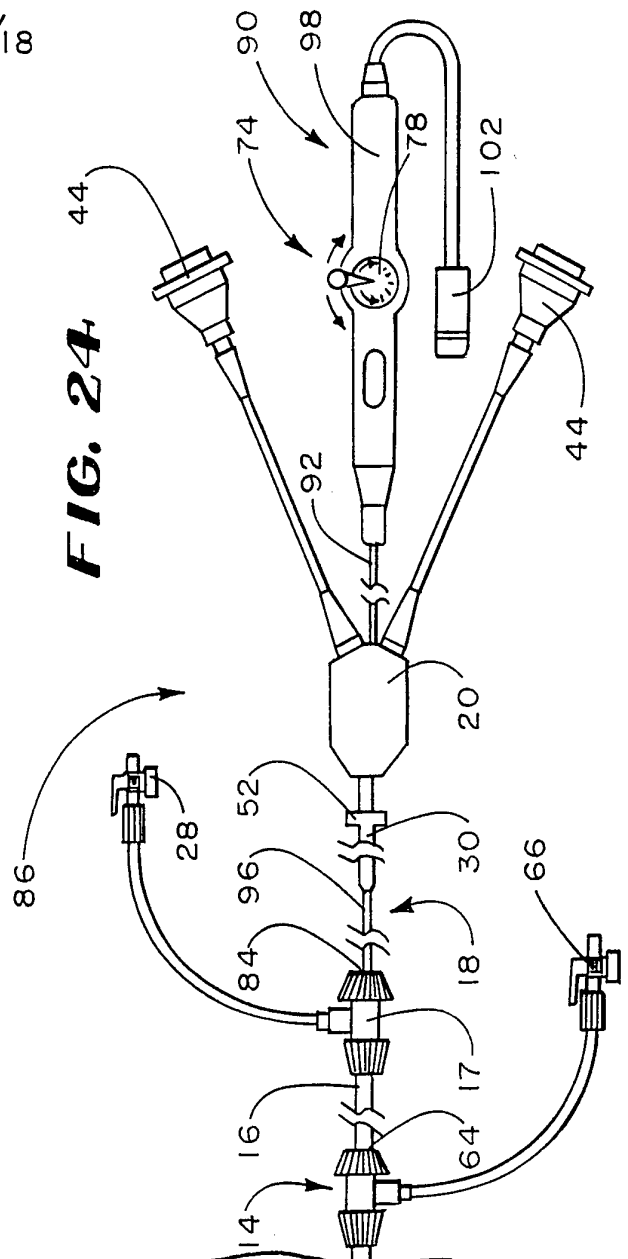

FIG. 24



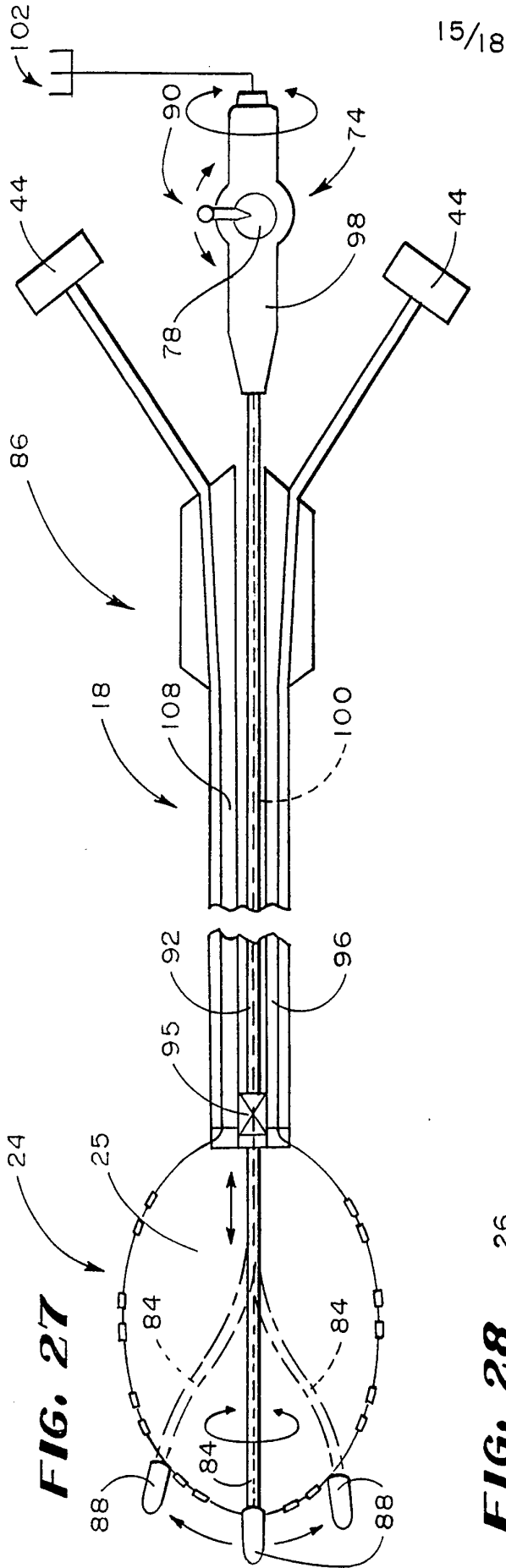

FIG. 27

15/18

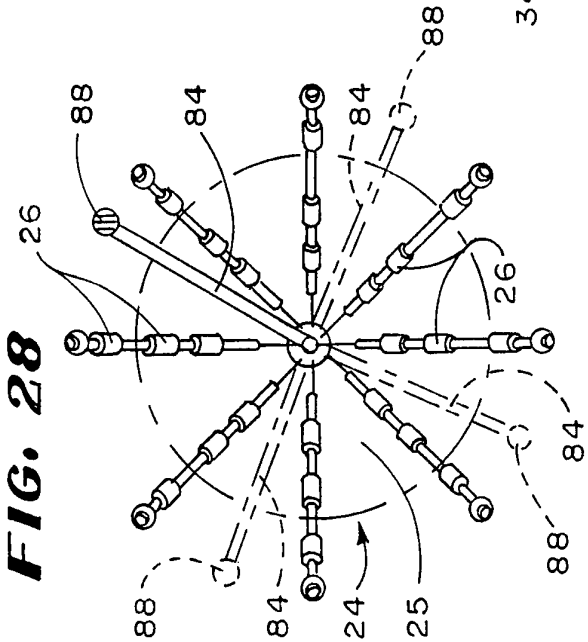

FIG. 28

FIG. 29

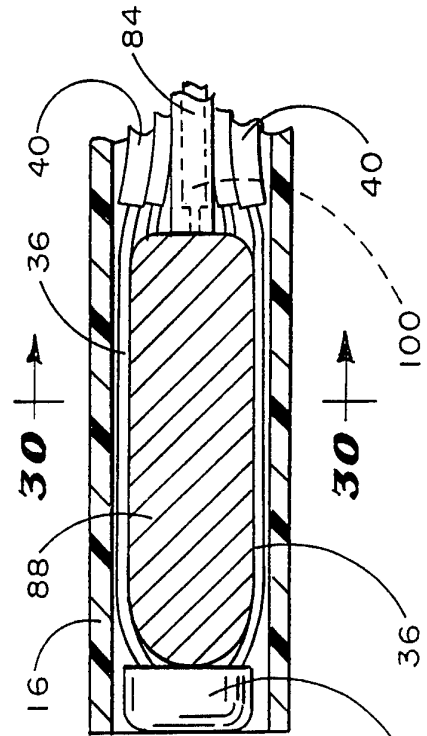

FIG. 30

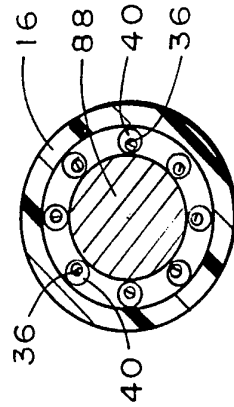

FIG. 31

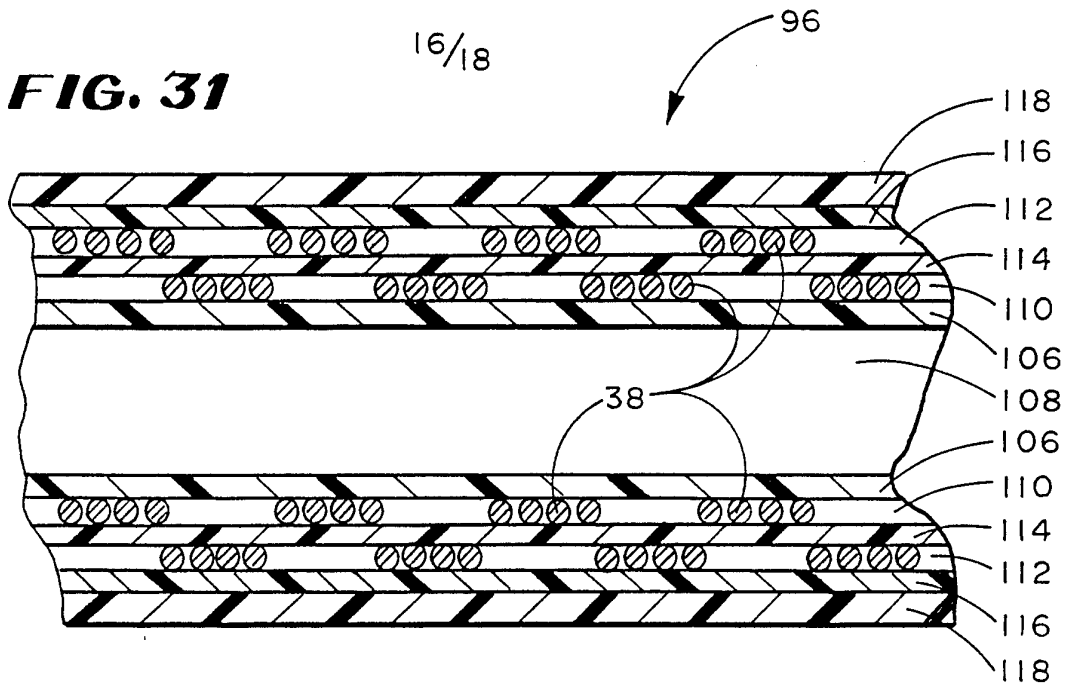

FIG. 32

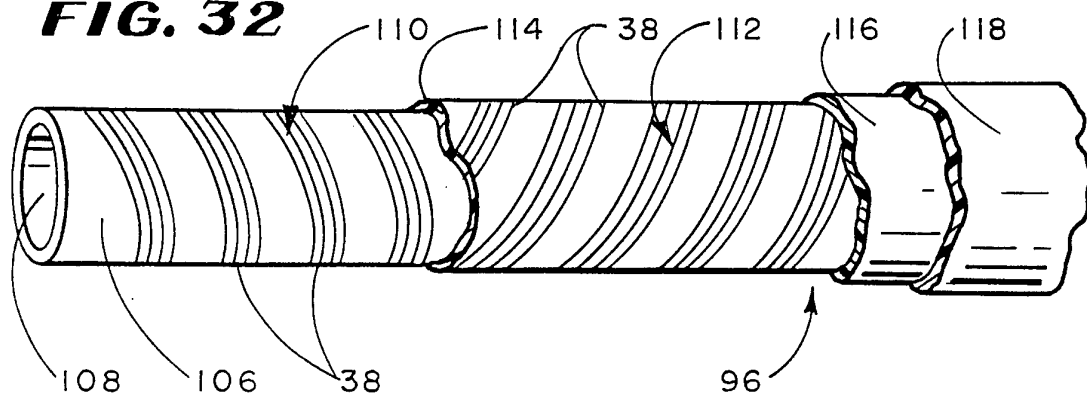
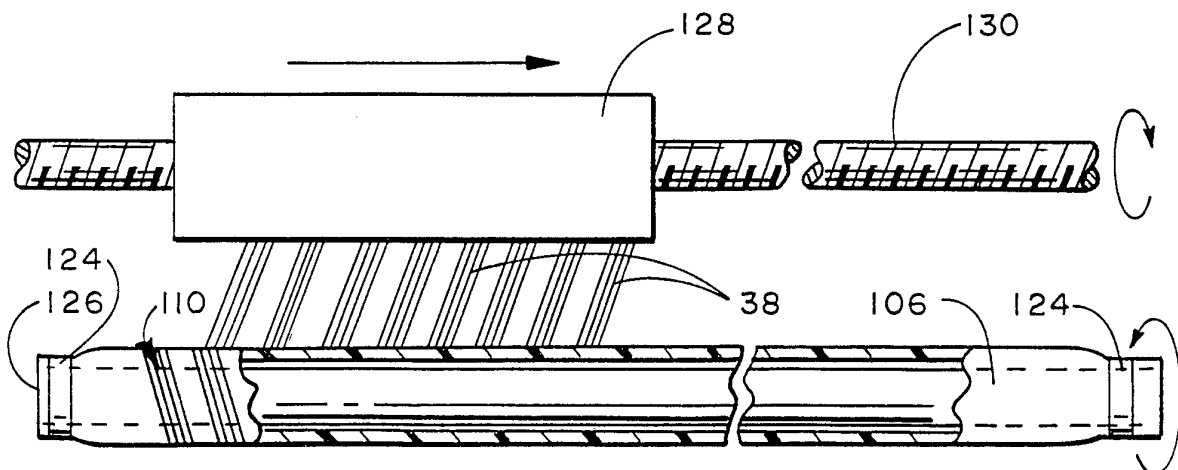

FIG. 33



17/18

FIG. 34

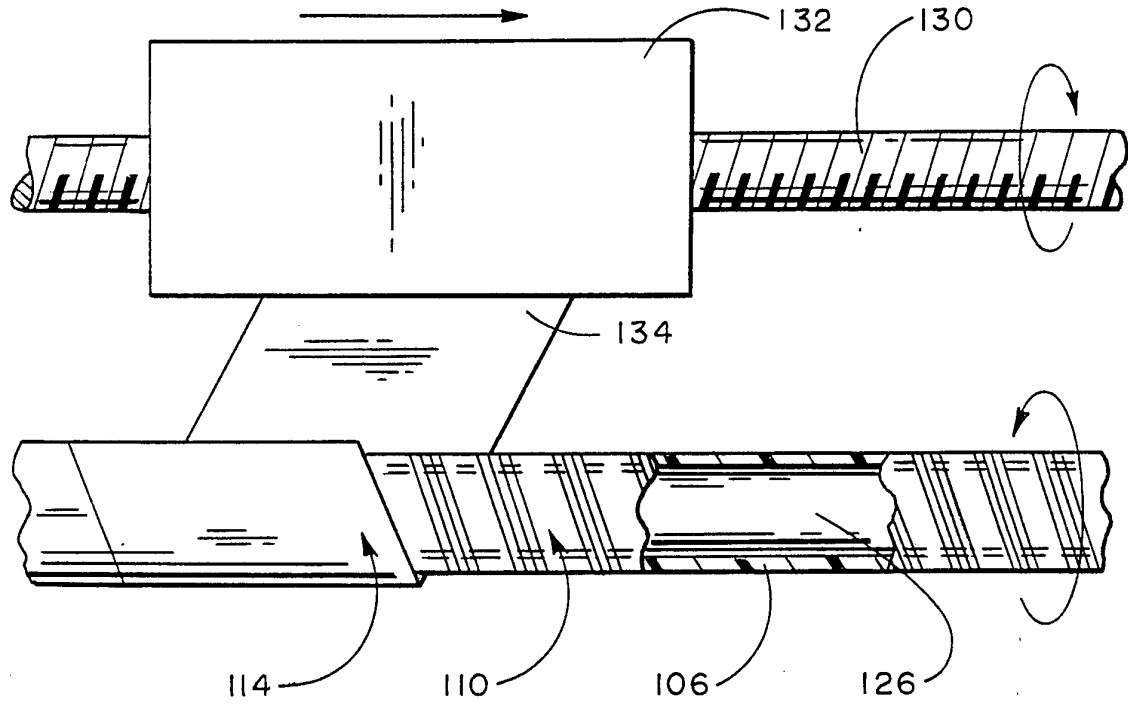
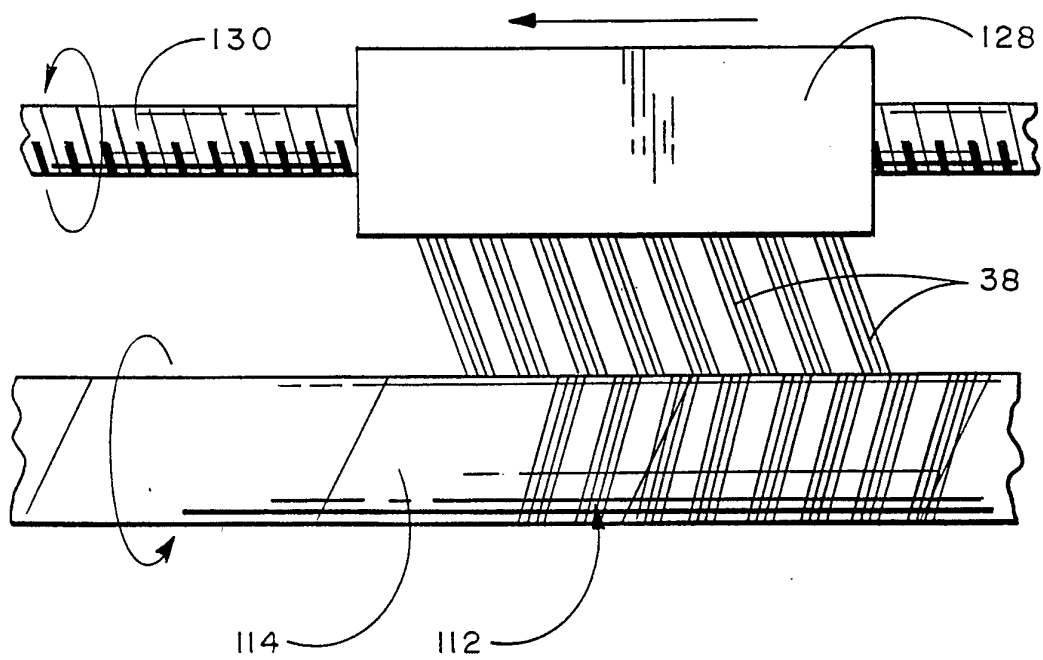

FIG. 35



18/18

FIG. 36

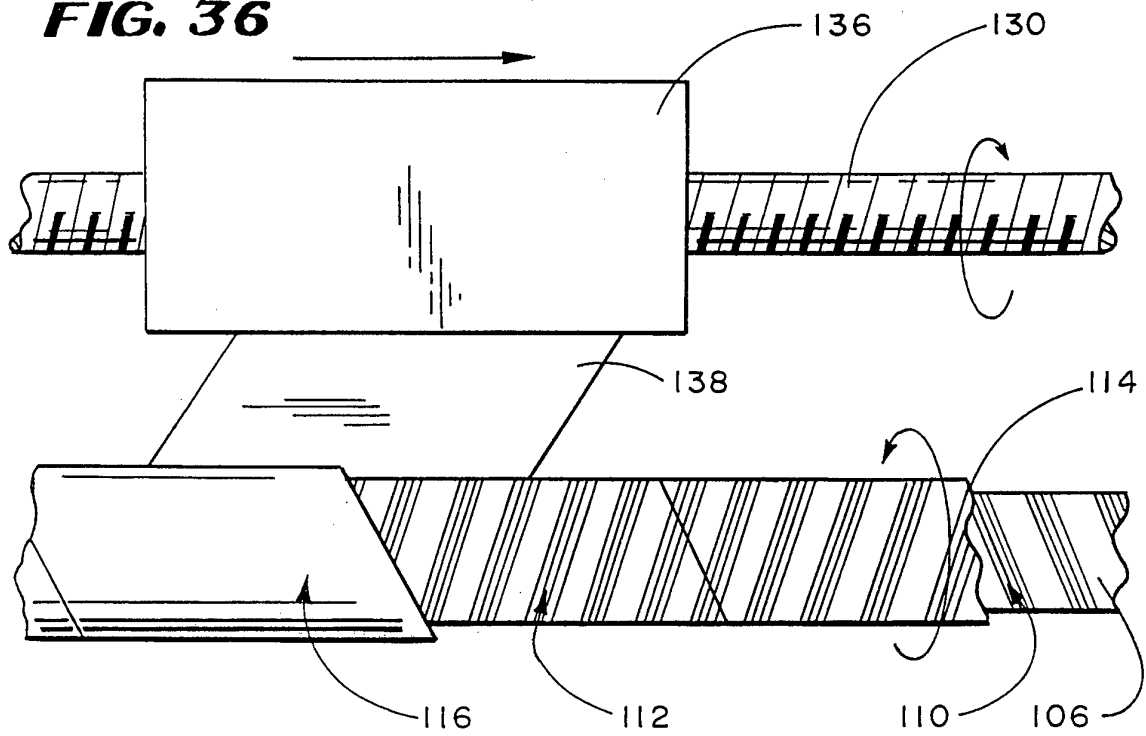

FIG. 37

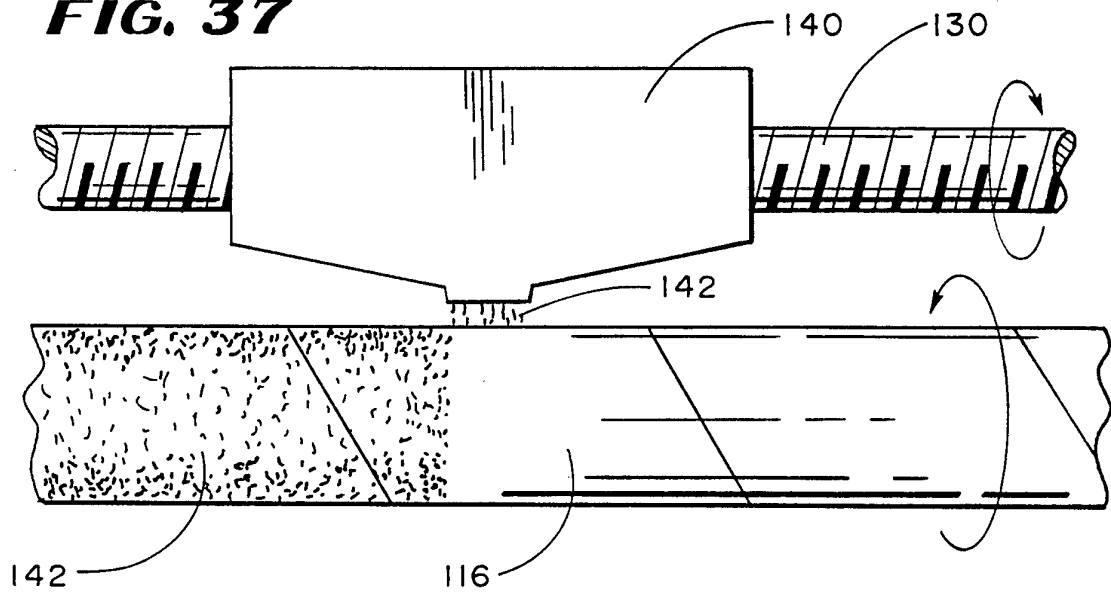
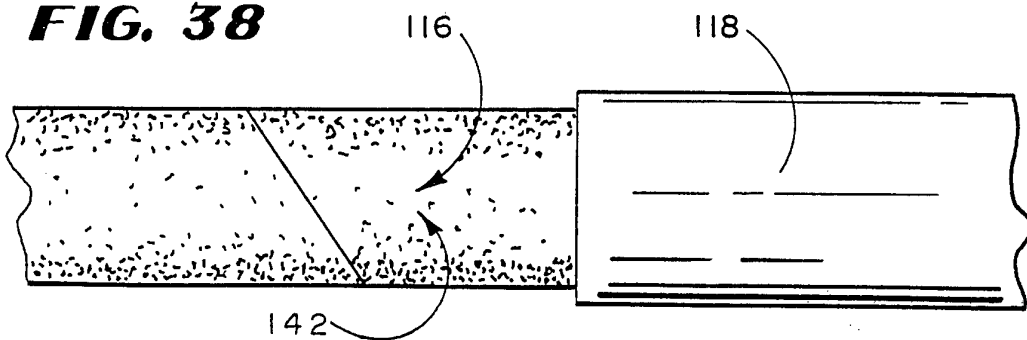

FIG. 38



INTERNATIONAL SEARCH REPORT

International application No.
PCT/US94/02780

A. CLASSIFICATION OF SUBJECT MATTER

IPC(5) :A61B 5/04

US CL :Please See Extra Sheet.

According to International Patent Classification (IPC) or to both national classification and IPC

B. FIELDS SEARCHED

Minimum documentation searched (classification system followed by classification symbols)

U.S. : 128/004, 642; 604/263; 607/119, 122, 123, 125, 126

Documentation searched other than minimum documentation to the extent that such documents are included in the fields searched

NONE

Electronic data base consulted during the international search (name of data base and, where practicable, search terms used)

NONE

C. DOCUMENTS CONSIDERED TO BE RELEVANT

Category*	Citation of document, with indication, where appropriate, of the relevant passages	Relevant to claim No.
X --- Y	US, A, 3,844,292, (BOLDUC), 29 October 1974. See entire document.	18, 21 ----- 19, 20, 22-24
Y	US, A, 4,940,064, (DESAI), 10 July 1990. See entire document.	1-5, 10, 12-14, 16, 17, 19, 20, 22-24, 26-28, 31-33, 35-37
Y, P	US, A, RE. 34,502, (WEBSTER, JR.), 11 January 1994. See entire document.	1-5, 9, 10, 12-14, 16, 17

Further documents are listed in the continuation of Box C. See patent family annex.

* Special categories of cited documents:	*T* later document published after the international filing date or priority date and not in conflict with the application but cited to understand the principle or theory underlying the invention
A document defining the general state of the art which is not considered to be part of particular relevance	*X* document of particular relevance; the claimed invention cannot be considered novel or cannot be considered to involve an inventive step when the document is taken alone
E earlier document published on or after the international filing date	*Y* document of particular relevance; the claimed invention cannot be considered to involve an inventive step when the document is combined with one or more other such documents, such combination being obvious to a person skilled in the art
L document which may throw doubts on priority claim(s) or which is cited to establish the publication date of another citation or other special reason (as specified)	*G* document member of the same patent family
O document referring to an oral disclosure, use, exhibition or other means	
P document published prior to the international filing date but later than the priority date claimed	

Date of the actual completion of the international search

11 JUNE 1994

Date of mailing of the international search report

JUL 20 1994

Name and mailing address of the ISA/US

Commissioner of Patents and Trademarks

Box PCT

Washington, D.C. 20231

Facsimile No. (703) 305-3230

Authorized officer

JEFFREY R. JASTRZAB

Telephone No. (703) 308-2097

INTERNATIONAL SEARCH REPORT

International application No.
PCT/US94/02780

C (Continuation). DOCUMENTS CONSIDERED TO BE RELEVANT

Category*	Citation of document, with indication, where appropriate, of the relevant passages	Relevant to claim No.
X --- Y	US, A, 4,911,148, (SOSNOWSKI ET AL.), 27 March 1990. See entire document.	29 ----- 1-5, 10, 12-14, 16, 17, 26, 27, 31-33, 35-37
Y	DE, A, 4,025,369, (NITSCH), 07 February 1991. See entire document.	6, 7, 13, 14

INTERNATIONAL SEARCH REPORT

International application No.
PCT/US94/02780

Box I Observations where certain claims were found unsearchable (Continuation of item 1 of first sheet)

This international report has not been established in respect of certain claims under Article 17(2)(a) for the following reasons:

1. Claims Nos.:
because they relate to subject matter not required to be searched by this Authority, namely:

2. Claims Nos.:
because they relate to parts of the international application that do not comply with the prescribed requirements to such an extent that no meaningful international search can be carried out, specifically:

3. Claims Nos.:
because they are dependent claims and are not drafted in accordance with the second and third sentences of Rule 6.4(a).

Box II Observations where unity of invention is lacking (Continuation of item 2 of first sheet)

This International Searching Authority found multiple inventions in this international application, as follows:

Please See Extra Sheet.

1. As all required additional search fees were timely paid by the applicant, this international search report covers all searchable claims.

2. As all searchable claims could be searched without effort justifying an additional fee, this Authority did not invite payment of any additional fee.

3. As only some of the required additional search fees were timely paid by the applicant, this international search report covers only those claims for which fees were paid, specifically claims Nos.:

4. No required additional search fees were timely paid by the applicant. Consequently, this international search report is restricted to the invention first mentioned in the claims; it is covered by claims Nos.:

Remark on Protest

- The additional search fees were accompanied by the applicant's protest.
 No protest accompanied the payment of additional search fees.

INTERNATIONAL SEARCH REPORT

International application No.
PCT/US94/02780

A CLASSIFICATION OF SUBJECT MATTER:

US CL :

128/642

BOX II. OBSERVATIONS WHERE UNITY OF INVENTION WAS LACKING

This ISA found multiple inventions as follows:

- I. Claims 1-11 and 18-20 drawn to the catheter system with two catheters and a guide sheath, and the corresponding method classified in Class 128, subclass 642.
- II. Claims 12-17 drawn to the three catheter system, classified in Class 128, subclass 642.
- III. Claims 22-28 drawn to the catheter and sheath system with an elastic memory sheath, and the corresponding method, classified in Class 128, subclass 642.
- IV. Claims 29 and 30 drawn to the sheath with deflecting means, classified in Class 604, subclass 263.
- V. Claims 31-37 drawn to the system with a catheter and deflectable sheath and the corresponding method, classified in Class 128, subclass 642.
- VI. Claims 21 and 38-40 drawn to the hemostatic sheath and guide sheath and the corresponding method, classified in Class 128, subclass 642.