



US 20020180942A1

(19) **United States**

(12) **Patent Application Publication**

Suzuki et al.

(10) **Pub. No.: US 2002/0180942 A1**

(43) **Pub. Date: Dec. 5, 2002**

(54) **PROJECTION EXPOSURE APPARATUS,
PROJECTION EXPOSURE METHOD AND
METHOD OF MANUFACTURING THE
PROJECTION EXPOSURE APPARATUS**

(30) **Foreign Application Priority Data**

Nov. 7, 1997 (JP)..... 9-322482

Publication Classification

(75) Inventors: **Kenji Suzuki**, Koshigaya-shi (JP);
Takashi Mori, Fujisawa-shi (JP)

(51) **Int. Cl.⁷** **G03B 27/54**
(52) **U.S. Cl.** **355/67; 355/53; 355/55; 359/350;**
355/30

Correspondence Address:

Mitchell W. Shapiro
Miles & Stockbridge P.C.
Suite 500
1751 Pinnacle Drive
McLean, VA 22102-3833 (US)

(57) **ABSTRACT**

(73) Assignee: **Nikon Corporation**

An exposure device with a higher resolution, comprising a light source(1), an illumination optical system(3) for illuminating a pattern on a projection reticle(R) by a light beam from the light source(1), and a projection optical system(4) for projecting the image of the pattern on a photosensitive surface on a photosensitive wafer(W), wherein the light source(1) supplies light whose wavelength is shorter than 193 nm, a band narrowing device(2) which narrows the bandwidth of the spectrum of the light supplied by the light source(1), is provided, and the projection optical system includes a plurality of refractive optical devices all made of CaF₂.

(21) Appl. No.: **10/162,064**

(22) Filed: **Jun. 5, 2002**

Related U.S. Application Data

(63) Continuation of application No. 09/565,119, filed on May 4, 2000, now abandoned, which is a continuation-in-part of application No. PCT/JP98/04999, filed on Nov. 6, 1998.

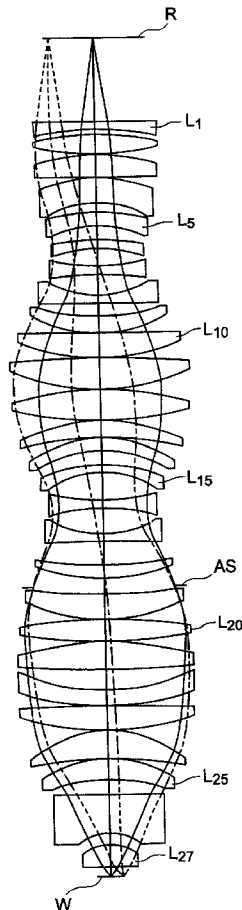

FIG. 1

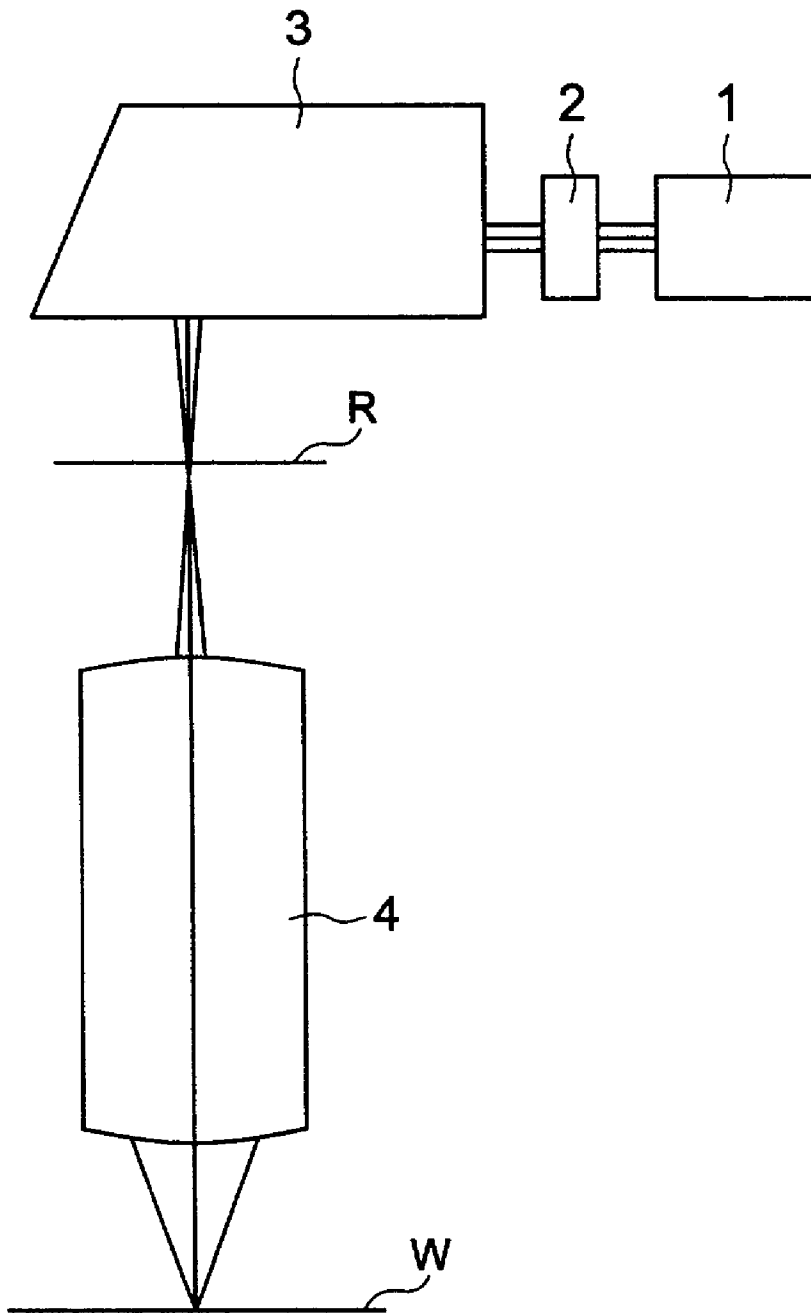

FIG. 2

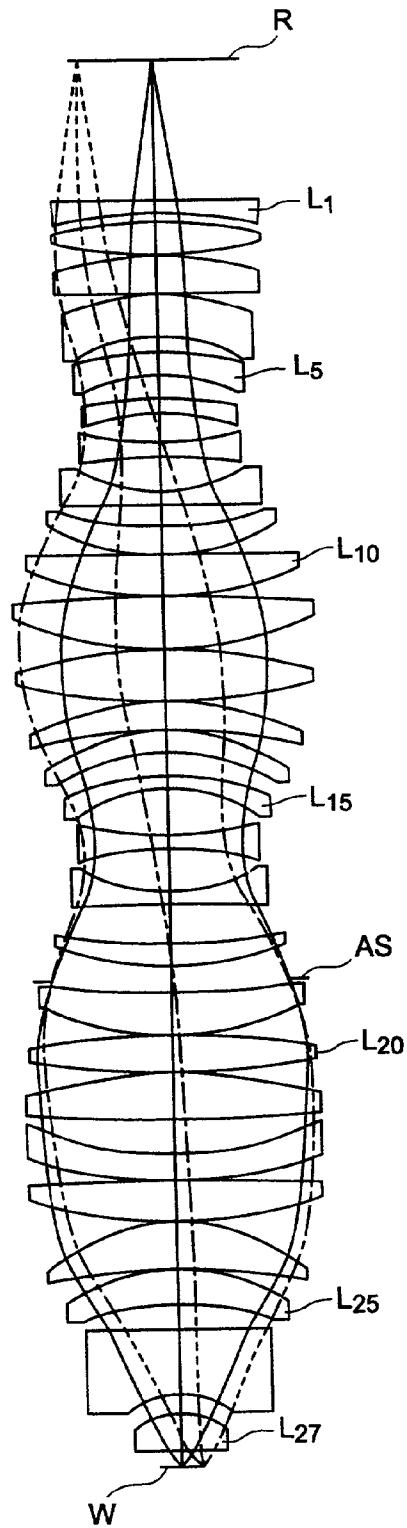

FIG. 3E

COMA (B)

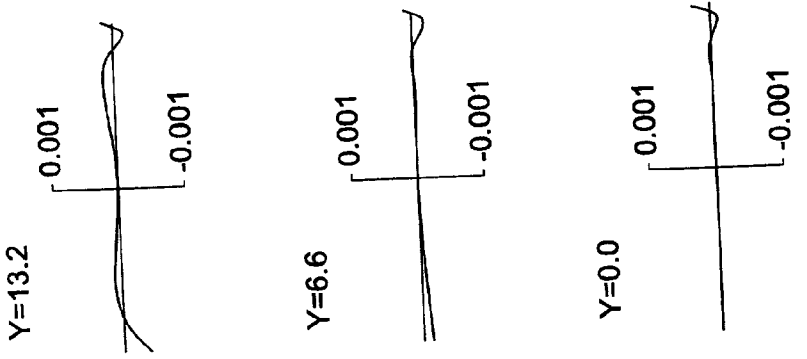

FIG. 3D

COMA (A)

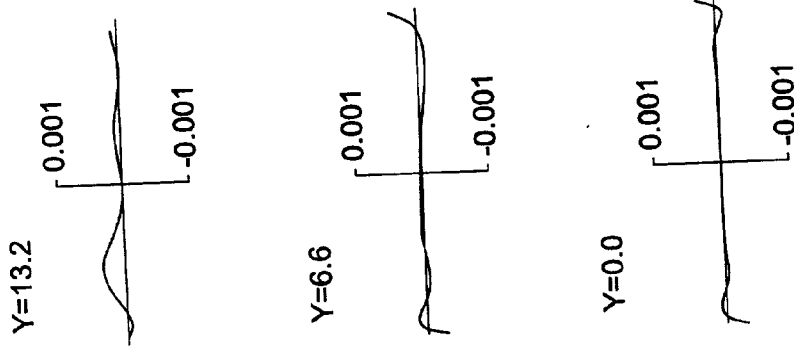
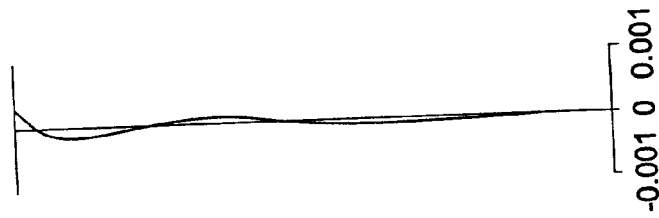

FIG. 3A FIG. 3B FIG. 3C

SPHERICAL ABERRATION

NA=0.6



ASTIGMTISM

Y=13.2



DISTORTION

Y=13.2

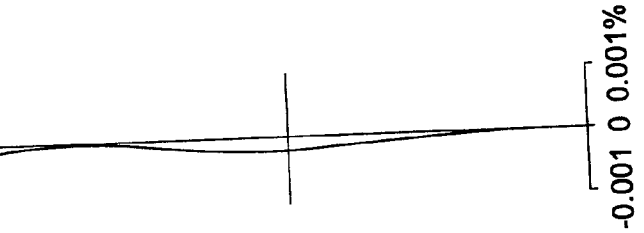

FIG. 4

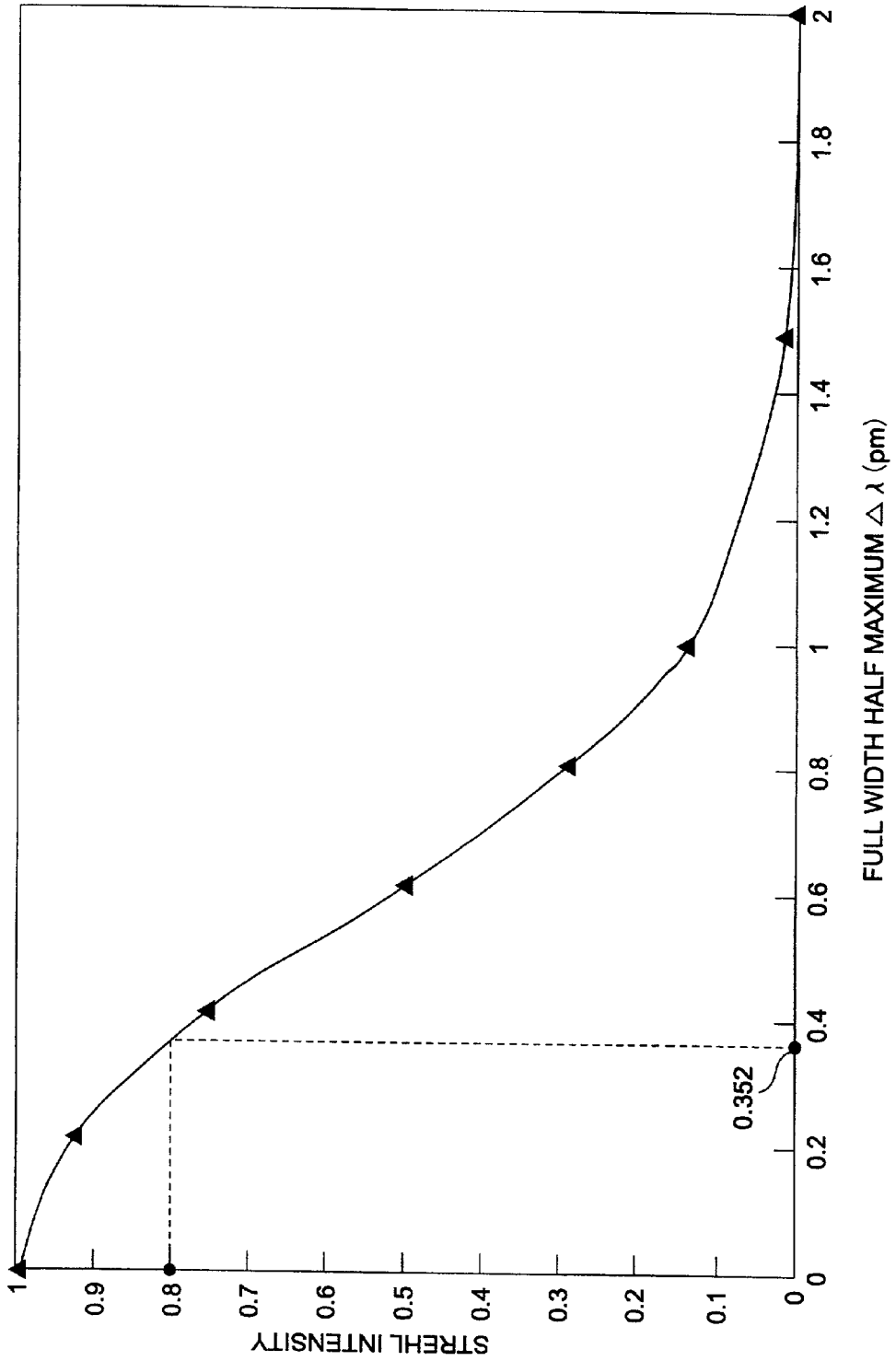
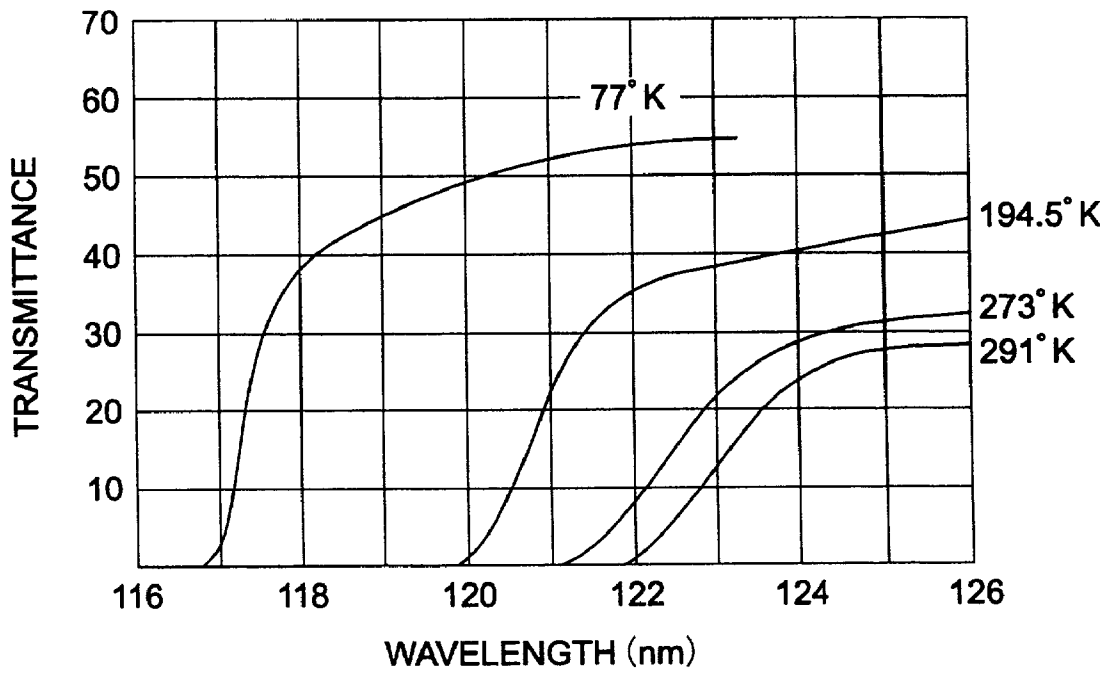

FIG. 5



**PROJECTION EXPOSURE APPARATUS,
PROJECTION EXPOSURE METHOD AND
METHOD OF MANUFACTURING THE
PROJECTION EXPOSURE APPARATUS**

[0001] This application claims the benefit of International application PCT/JP98/04999 which is hereby incorporated by reference.

BACKGROUND OF THE INVENTION

[0002] 1. Field of the Invention

[0003] The present invention relates to a projection exposure apparatus used for transferring a mask (projection original) pattern onto a substrate (work) in a lithography process for manufacturing a device such as a semiconductor device, an imaging device, a flat panel display device (e.g. a liquid crystal display device), a thin-film magnetic head, etc. The present invention also relates to a projection exposure method of projecting the mask pattern on the substrate in the lithography process. The present invention further relates to a method of manufacturing the projection exposure apparatus.

[0004] 2. Related Background Arts

[0005] With a higher integration of the semiconductor device, a projection exposure apparatus used in a photolithography manufacturing process thereof has achieved its remarkable progresses over the recent years.

[0006] A resolution R of the projection exposure apparatus utilizing the light is, as known by way of the Rayleigh's formula, expressed such:

$$R = c\lambda/NA$$

[0007] where λ is an exposure wavelength, NA is an image-side numerical aperture of the projection optical system, and c is a constant determined by a process, such as a resolution of a resist. The higher integration of the semiconductor device is actualized by making the pattern much finer, and hence, for resolving the finer pattern, as obvious from the formula given above, it is required that the exposure wavelength λ be shortened and NA of the exposure light be increased.

[0008] Over the recent years, 0.35 μm line-and-space processing has been attained by use of a projection optical system having a numerical aperture of 0.6, wherein 365 nm lines of a mercury lamp serve as a light source. This makes it possible to attain a photolithography-based mass production of a 64 Mbit random access memory. Further, a development of an exposure apparatus is underway, wherein the light source is a krypton fluoride (KrF) excimer laser ($\lambda=248$ nm) or an argon fluoride (ArF) excimer laser ($\lambda=193$ nm). Processing of 0.25~0.18 μm line-and-space, which is required of a 256 Mbit or 1 Gbit random access memory class, is on the verge of its actualization by light.

[0009] The conventional technology is, however, limited in resolving power to the 0.25~0.18 μm line-and-space processing, and, if aiming at resolving power of a 0.1 μm class over this, it is required that the exposure wavelength be made by far shorter, and the numerical aperture NA of the exposure light be further increased, or there be combined a variety of super resolution techniques. If scheming to enhance the resolution by increasing NA of the exposure light among those schemes, this might lead to a rapid

scale-up of the projection optical system and might need an optical material required to exhibit a high uniformity and a high accuracy as well. That scheme might be forced to have an extremely large difficulty in processing of the optical material, and be poor of reality if based on the premise of its mass production. Further, the variety of super resolution techniques proposed at the present have a strong dependency upon the pattern and therefore impose a large restraint on a circuit design, so that there must be no alternative but to take a step backward for entirely adopting them.

[0010] On the other hand, there are active pursuits for systems using energies other than the light such as X-rays, electron beams, etc., and, if the photolithography eventually encounters the limit, it follows that technology will shift to those systems. It predominance of the light is absolute in the field of the exposure apparatus, and there must be a necessity for a crucial motivation for shifting to other systems by venturing upon a cutoff of extensions of know-how and technologies accumulated through the researches and experiences over the past long years.

[0011] After all, it may be said that a farther pursuit for the limit of shortening the wavelength in the photography is only one way of overcoming all the difficulties.

SUMMARY OF THE INVENTION

[0012] It is an object of the present invention to provide a projection exposure apparatus exhibiting much finer resolving power. It is another object of the present invention to provide a projection exposure method of exposing a photo-sensitive substrate to the light via a pattern formed on a projection original (e.g. mask, reticle). It is a further object of the present invention to provide a method of manufacturing the projection exposure apparatus.

[0013] The present inventors made researches cumulatively in order to obviate the above problems, and put an emphasis, to start with, upon a fluorine dimer (F_2) laser by way of one example of a light source, of which an oscillation wavelength is shorter than an ArF excimer laser beam ($\lambda=193$ nm) but is not so short as no available refractive optical material exists, and from which a practical output can be obtained. According to a literature (Ohara: "Extreme Ultraviolet Laser", Optics, 23 (1994) 626-627), the oscillation wavelength of the F_2 laser is 157 nm, and this is a laser light source capable of obtaining an output of an MW (Mega Watt) class or larger. Besides, the F_2 laser has such a characteristic that a spectral width thereof is as narrow as 1~5 pm even if a band narrowing device is not used.

[0014] Next, in the optical system of which the light source is the ArF excimer laser, synthetic silica glass (SiO_2) and a calcium fluoride crystal (CaF_2) are usable as refractive optical materials. In an area of 157 nm of the F_2 laser, a transmissivity of SiO_2 is extremely declines, and therefore this synthetic silica glass is hard to use as the refractive optical material. An absorption end of CaF_2 is, however, on the order of 122 nm at a normal temperature (G. Cheroff and S. P. Keller: "Measurements of Rise and Decay Timers of Stimulated Emission from Phosphors", J. Opt. Soc. Am, 47, 440-441 (1957)), and hence there is a possibility in which CaF_2 can be used in 157 nm.

[0015] Such being the case, the present inventors tentatively measured the transmissivity of CaF_2 in the extreme

ultraviolet region. FIG. 5 shows one example of the measured result. As shown in FIG. 5, CaF₂ exhibits substantially a fixed transmissivity with respect to the light of 157 nm. It is considered that the transmissivity is by far enhanced by further restraining a defect in oxygen in CaF₂, and hence eventually CaF₂ is, it can be said, usable for the light of 157 nm.

[0016] Next, it is required for designing the projection optical system in fact that there be known a refractive index n and a dispersion $dn/d\lambda$ of CaF₂ in 157 nm. Then, the refractive index n and the dispersion $dn/d\lambda$ of CaF₂ in 157 nm are obtained by extrapolating a dispersion formula (I. H. Malitson: "A redetermination of Some Optical Properties of Calcium Fluorides", Appl. Opt. 2(1963), 1103-1107) obtained in the area up to 185 nm.

[0017] Further, as a comparative example, the refractive index n and the dispersion $dn/d\lambda$ of SiO₂ in each of 248 nm and 193 nm are obtained based on another literature (I. M. Malitson, "Interspecimen Comparison of Refractive Index of Fused Silica", J. Opt. Soc. Am, 35(1965), 1205-1209). The following is the result thereof.

[0018] CaF₂: 157 nm $n=1.55861104$ $dn/d\lambda=-2.55\times 10^{-3}$

[0019] SiO₂: 248 nm $n=1.50855076$ $dn/d\lambda=-5.61\times 10^{-4}$

[0020] SiO₂: 193 nm $n=1.56076908$ $dn/d\lambda=-1.29\times 10^{-3}$

[0021] When using the KrF excimer laser beam ($\lambda=248$ nm) of which a spectral half bandwidth (full width half maximum) is on the order of 1 pm, a dispersion of SiO₂ is comparatively small, and hence there is almost no chromatic aberration even when constructing the projection optical system of all refractive system using only SiO₂ on condition that NA=0.6 or thereabouts. When using the ArF excimer laser beam ($\lambda=193$ nm), however, the dispersion of SiO₂ is comparatively large even when narrowing the spectral width down to approximately 1 pm, and it is therefore difficult to construct the projection optical system of the all refractive system using SiO₂, wherein the chromatic aberration is corrected by using CaF₂ in combination.

[0022] The dispersion of CaF₂ with respect to the F₂ laser beam ($\lambda=157$ nm) is substantially equal to the dispersion of SiO₂ in 193 nm as shown in the above table. Accordingly, in the case of constructing the projection optical system of the all refractive system using only CaF₂ in the region of 157 nm exhibiting a spectral width of approximately 1 pm, it is difficult to correct the chromatic aberration. This being the case, the F₂ laser is used as a light source, and, when employing the projection optical system of the all refractive system using only CaF₂, it can be understood that there is a necessity for scheming to narrow the band of the wavelength of the light source.

[0023] As to how much the band should be narrowed, a condition required of a half bandwidth $\Delta\lambda$ may be expressed such as:

$$\Delta\lambda \leq kL/NA^2 \quad (1)$$

[0024] where $\Delta\lambda$ is the half bandwidth (full width half maximum) of a spectrum after the band has been narrowed, L is an inter-object-image distance (overall distance, conjugate distance) in the projection optical system, i.e., an axial distance between an object (a pattern surface of a projection original) and an image (photosensitive surface of a photo-

sensitive substrate), NA is an image-side numerical aperture of the projection optical system, and k is a constant determined by specifications of the projection optical system.

[0025] According to the present invention devised based on the contemplation described above, a projection exposure apparatus comprises a light source;

[0026] an illumination optical system which illuminates a pattern on a projection original with a light flux emitted from the light source, and a projection optical system which forms a pattern image on a photosensitive surface of a photosensitive substrate. The light source supplies light beams having a wavelength shorter than 193 nm, and there is disposed a band narrowing device which narrows a band of a spectrum of light having a wavelength shorter than 193 nm, supplied from the light source. The projection optical system includes a plurality of refractive optical elements, and the refractive optical elements constituting the projection optical system are all consisting of CaF₂.

[0027] On this occasion, it is preferable that a band of light is narrowed to satisfy the following condition:

$$\Delta\lambda \leq 7.0 \times 10^{-13} \cdot L/NA^2 \quad (2)$$

[0028] where $\Delta\lambda$ is a half-width of a spectrum of the light supplied from the light source, L is a distance on the optical axis from a pattern surface on a projection original to a photosensitive surface of a photosensitive substrate, and NA is an image-side numerical aperture of the projection optical system.

[0029] According to the present invention, a projection exposure apparatus comprises an illumination optical system which illuminates a pattern on projection a original with a light flux emitted from a light source, and a projection optical system which projects a pattern image on a photosensitive substrate. The light source supplies light beams having a wavelength shorter than 193 nm, a band narrowing device which narrows a band of a spectrum of light having a wavelength shorter than 193 nm, supplied from the light source, is disposed, and the band narrowing device narrows the band of light emitted from the light source so as to satisfy the following condition:

$$\Delta\lambda \leq 7.0 \times 10^{-13} \cdot L/NA^2$$

[0030] where $\Delta\lambda$ is a half-width of a spectrum of the light after the band thereof has been narrowed by the band narrowing device, L is a distance on the optical axis from a pattern surface on the projection original to the photosensitive surface of the photosensitive substrate, and NA is a photosensitive-substrate-side numerical aperture of the projection optical system.

[0031] Further, according to the present invention, a projection exposure apparatus comprises an illumination optical system which illuminates a pattern on a projection original with illumination light having a wavelength shorter than 193 nm, and a projection optical system which forms a pattern image on a photosensitive surface of a photosensitive substrate. The illumination optical system supplies the illumination light having such a spectral width as to satisfy the following condition:

$$\Delta\lambda \leq 7.0 \times 10^{-13} \cdot L/NA^2$$

[0032] where $\Delta\lambda$ is a half-width of a spectrum of the illumination light given from the illumination optical system, L is a distance from a pattern surface on the projection

original to the photosensitive surface of the photosensitive substrate, and NA is a photosensitive-substrate-side numerical aperture of the projection optical system. The projection optical system is constructed of refractive optical elements.

[0033] According to the present invention, a projection exposure apparatus comprises an illumination optical system which illuminates a pattern on a projection original with illumination light having a wavelength shorter than 193 nm, and a projection optical system which forms a pattern image on a photosensitive surface of a photosensitive substrate. The projection optical system is constructed of only refractive optical elements, and the illumination optical system supplies the illumination light having such a spectral width that a Strehl intensity on an image surface of the projection optical system is 0.8 or larger.

[0034] According to the present invention, a projection exposure method comprises a step of supplying light having a wavelength shorter than 193 nm, a step of narrowing a band of the light, a step of guiding the band-narrowed light to a projection original having a predetermined pattern and illuminating the projection original with the light, and a step of forming a pattern image on a photosensitive surface of a photosensitive substrate by use of a projection optical system including a plurality of refractive optical elements, wherein all the refractive optical elements in the projection optical system are composed of CaF₂.

[0035] According to the present invention, a projection exposure method comprises a step of supplying light having a wavelength shorter than 193 nm, a step of narrowing a band of a spectrum of the light having the wavelength shorter than 193 nm, a step of illuminating a pattern on a projection original with the band-narrowed light, and a step of projecting a pattern image on a photosensitive substrate by use of a projection optical system. The band of light is narrowed to satisfy the following condition:

$$\Delta\lambda \leq 7.0 \times 10^{-13} \cdot L / NA^2$$

[0036] where $\Delta\lambda$ is a half-width of the spectrum of the light after the band thereof has been narrowed in the band narrowing step, L is a distance from a pattern surface on the projection original to the photosensitive surface of the photosensitive substrate, and NA is a photosensitive-substrate-side numerical aperture of the projection optical system.

[0037] According to the present invention, a projection exposure method comprises a step of illuminating a pattern on a projection original with illumination light having a wavelength shorter than 193 nm, and a step of forming a pattern image on a photosensitive surface of a photosensitive substrate by a projection optical system. The illuminating step involves supplying the illumination light having such a spectral width as to satisfy the following condition:

$$\Delta\lambda \leq 7.0 \times 10^{-13} \cdot L / NA^2$$

[0038] where $\Delta\lambda$ is a half-width of a spectrum of the illumination light given from the illumination optical system, L is a distance from a pattern surface on the projection original to the photosensitive surface of the photosensitive substrate, and NA is a photosensitive-substrate-side numerical aperture of the projection optical system, and the projecting step involves guiding the light from the projection original to the photosensitive substrate via only refractive optical elements.

[0039] According to the present invention, a method of manufacturing a projection exposure apparatus comprises a step of preparing an illumination optical system which illuminates a pattern on a projection original with illumination light having a wavelength shorter than 193 nm, and a step of preparing a projection optical system which forms a pattern image on a photosensitive surface of a photosensitive substrate by a projection optical system. The illumination optical system is constructed to supply the illumination light having such a spectral width as to satisfy the following condition:

$$\Delta\lambda \leq 7.0 \times 10^{-13} \cdot L / NA^2$$

[0040] where $\Delta\lambda$ is a half-width of a spectrum of the illumination light given from the illumination optical system, L is a distance from a pattern surface on the projection original to the photosensitive surface of the photosensitive substrate, and NA is a photosensitive-substrate-side numerical aperture of the projection optical system. The projection optical system preparing step includes a sub-step of preparing a plurality of refractive optical elements, and a sub-step of assembling the plurality of refractive optical elements. The method further comprises a step of assembling the illumination optical system and the projection optical system.

BRIEF DESCRIPTION OF DRAWINGS

[0041] FIG. 1 is a schematic view showing an exposure apparatus in one embodiment of the present invention;

[0042] FIG. 2 is a sectional view showing a geometry of lenses of a projection optical system in the embodiment;

[0043] FIGS. 3A to 3E are diagram showing aberrations of the projection optical system in the embodiment;

[0044] FIG. 4 is a graph showing a relationship between a full width half maximum of a spectrum of light and a Strehl intensity when an image height is 0; and

[0045] FIG. 5 is a graph showing a transmittance of CaF₂ in an extreme ultraviolet region.

DESCRIPTION OF THE PREFERRED EMBODIMENTS

[0046] An embodiment of the present invention will be described with reference to the drawings. FIG. 1 shows one embodiment of a projection exposure apparatus according to the present invention. This projection exposure apparatus includes a light source 1, a band narrowing device 2 which narrows a band of a light flux emitted from the light source 1, an illumination optical system 3 which substantially illuminates a pattern on a reticle R defined as a projection original with the light flux of which the band-width is narrowed by the band narrowing device 2, and a projection optical system 4 which forms an image of the pattern on the reticle R, on a photosensitive surface of a wafer W defined as a photosensitive substrate. In this embodiment, the light source 1 involves the use of an F₂ laser, and the projection optical system 4 involves the use of a dioptric optical system consisting of only CaF₂.

[0047] Note that refractive optical elements (a lens element, plane-parallel plane, etc.) used for the illumination optical system 3 are all consisting of CaF₂ (fluorite), and a gas within the illumination optical system 3 is substituted by

helium gas. Further, in the projection optical system 4 also, a gas within the projection optical system 4 is substituted by helium gas. Moreover, a space extending from the light source 1 to the illumination optical system 3, a space between the illumination optical system 3 and the projection optical system 4, and a space between the projection optical system 4 and the wafer W, are also substituted by helium gas.

[0048] Further, in this embodiment, there is used the reticle composed of any one of calcium fluoride(fluorite), synthetic silica doped with fluorine, magnesium fluoride, and quartz-crystal.

[0049] The wafer W having undergone an exposure process (a photolithography process) by the exposure apparatus in the present embodiment shown in FIG. 1, receives, after a developing process, an etching process of etching a developed area excluding a resist to a thickness required and further a resist removing process of removing the unnecessary resist after the etching process, thus finishing the wafer process. Then, upon the end of the wafer process, there are executed a dicing process of dicing the wafer into chips per circuit printed in an actual assembly process, a bonding process of arranging wires on the chips, and a packaging process of packaging per chip. Through these processes, a semiconductor device (LSI, etc.) is eventually manufactured. Note that what has been described so far shows the case of manufacturing the semiconductor device by the photolithography process in the wafer process using the exposure apparatus, however, a flat panel display device such as a liquid crystal display panel, a thin-film magnetic head and an imaging element (CCD, etc.) may also be manufactured as microelectronic devices.

[0050] FIG. 2 is a sectional view showing a geometry of lenses of the projection optical system 4. As shown in FIG. 2, in the projection optical system 4 in this embodiment, twenty seven pieces of lenses L₁~L₂₇ are used for convenience, and an aperture stop AS is disposed between the lens L₁₈ and the lens L₁₉.

[0051] Table 1 given as follows shows lens data and general system data of the projection optical system 4. In the lens data, a first column indicates a serial number of lens surfaces from the side of the reticle R, a second column "r" indicates a radius of curvature of each lens surface (the value is positive when the center of curvature exists in a light traveling direction), a third column "d" represents a spacing on the optical axis from one lens surface to the next lens surface to, and a fourth column represents a serial number of each lens.

[0052] A dispersion dn/dλ and a refractive index n of CaF₂ when the wavelength λ=157 nm, as already described, take the following values.

$$n=1.55861104$$

$$dn/d\lambda=-2.55 \times 10^{-3}$$

[0053] (Table 1)

[0054] [General System Data]

[0055] f (Focal Length): ∞

[0056] NA (Image-Side Numerical Aperture): 0.6

[0057] Y (Maximum Image Height): 13.2 mm

[0058] L (Inter-Object-Image-Distance): 1000 mm

[0059] β (Magnification): -0.25

[Lens Data]			
	r	d	
0	∞	95.00237	R
1	1382.43500	9.99995	L ₁
2	290.56564	6.88854	
3	337.30930	22.83077	L ₂
4	-228.40397	0.99995	
5	223.96164	26.60343	L ₃
6	5638.10100	0.99996	
7	173.41102	29.85645	L ₄
8	108.75761	10.28911	
9	201.84587	16.93097	L ₅
10	118.14040	16.54418	
11	245.26889	9.99994	L ₆
12	140.95817	21.01889	
13	-186.53319	9.99996	L ₇
14	408.48572	24.86013	
15	-98.85823	9.99995	L ₈
16	-1314.91100	13.74699	
17	-235.69460	20.32360	L ₉
18	-150.48008	0.99996	
19	-1228.13900	29.08275	L ₁₀
20	-225.05918	0.99996	
21	2054.03400	36.68527	L ₁₁
22	-246.05895	0.99994	
23	369.75733	37.47410	L ₁₂
24	-402.21348	0.99994	
25	200.19852	20.35150	L ₁₃
26	348.66335	1.23517	
27	139.73373	15.12963	L ₁₄
28	135.63799	17.51748	
29	155.75169	9.99993	L ₁₅
30	105.66389	33.28534	
31	-216.81489	9.99994	L ₁₆
32	202.60530	30.30447	
33	-111.55047	9.99994	L ₁₇
34	2557.24500	27.46258	
35	-427.54395	16.64567	L ₁₈
36	-207.78315	10.83833	
37	∞	7.95573	AS
38	-693.74216	29.12054	L ₁₉
39	-210.50921	0.99994	
40	645.10721	25.44942	L ₂₀
41	-564.81681	0.99994	
42	349.77884	33.19497	L ₂₁
43	-1234.38200	24.59543	
44	-218.84429	17.99995	L ₂₂
45	-335.23355	0.99995	
46	2803.58200	28.67252	L ₂₃
47	-315.15601	0.99994	
48	129.77179	33.28217	L ₂₄
49	400.41135	0.99993	
50	137.57804	23.37237	L ₂₅
51	186.79413	14.30647	
52	786.26228	48.20673	L ₂₆
53	52.81944	13.41916	
54	49.25582	25.05940	L ₂₇
55	501.39939	13.46716	
56	∞		W

[0060] FIGS. 3A-3E show a spherical aberration, an astigmatism, a distortion and a coma of the projection optical system in this embodiment. In each aberration graph, NA represents the image-side numerical aperture, and Y denotes the image height. In the astigmatism graph, the solid line M represents a meridional image surface, and the dotted line indicates a sagittal image surface. Further, the coma (A)

indicates a transverse aberration of the meridional rays. Moreover, a right half of the coma (B) indicates a transverse aberration in the sagittal direction of the sagittal rays, while a left half thereof represents a transverse aberration in the meridional direction of the sagittal rays.

[0061] As obvious from the respective aberration graphs, it can be understood that the projection optical system in this embodiment exhibits an excellent image forming performance.

[0062] FIG. 4 shows a relationship between a Strehl intensity and a half-width $\Delta\lambda$ of a light spectrum when the image height is 0 ($Y=0$). According to the Marechal criterion, if the Strehl intensity exceeds 0.8, it may be conceived that there is no aberration. In FIG. 4, a requirement for attain a Strehl intensity of 0.8 or larger is:

$$\Delta\lambda \leq 0.352 \text{ pm} \quad (3)$$

[0063] Therefore, from the formulae (1) and (3), the overall distance L is given such as $L=1000$ mm, and the numerical aperture NA is given by $NA=0.6$, and hence k is given by:

$$k=1.27 \times 10^{-13}$$

[0064] Accordingly, the formula (1) becomes:

$$\Delta\lambda \leq 1.27 \times 10^{-13} \cdot L/NA^2 \quad (4)$$

[0065] Namely, it is preferable that a band of wavelength of the light source is narrowed to satisfy the condition (4).

[0066] The k's value ($=1.27 \times 10^{-13}$) in the above conditions is a value given when using the projection optical system of which the data are shown in Table 1, and, if changing the geometry of the projection optical system, may be varied corresponding thereto.

[0067] Further, in the above discussion, the projection optical system constructed of the refractive optical members has been exemplified, but the present invention is not limited to this construction. For example, the projection optical system may be constructed of a combination of the refractive optical members and reflection type optical members (a concave mirror, a convex mirror), which is a so-called catadioptric system. In this case also, the k's value takes a predetermined value.

[0068] Thus, when considering the case where the projection optical system is constructed of the refractive optical members and a case of being constructed of the catadioptric system, it is preferable that the k's value meets the following condition (5):

$$k \leq 7.0 \times 10^{-13} \quad (5)$$

[0069] If the projection optical system is constructed to satisfy the above condition (5), it is feasible to obtain sufficient effects of the present invention.

[0070] Hence, the condition (1) given above turns out:

$$\Delta\lambda \leq 7.0 \times 10^{-13} \cdot L/NA^2 \quad (2)$$

[0071] If the projection optical system is constructed to meet this condition (2), it is possible to actualize the exposure apparatus having a high resolution while well correcting the various aberrations including a chromatic aberration. Further, when the exposure apparatus satisfying the condition (2) exposes the reticle pattern onto the photosensitive substrate, whereby a preferable semiconductor device can be manufactured.

[0072] Now, the projection exposure apparatus in the embodiment described above can be manufactured by the following method. To start with, there is prepared the illumination optical system which illuminates the pattern on the reticle with the illumination light having a wavelength shorter than 193 nm. In this case, the illumination optical system is so constructed as to supply the illumination light having such a spectral width as to satisfy the condition (2) given above. Then, the projection optical system which forms an image of the reticle pattern on the photosensitive surface of the photosensitive substrate, is prepared. What this projection optical system is prepared may involve preparing and assembling a plurality of refractive optical elements. Then, the illumination optical system and the projection optical system are connected to each other electrically, mechanically or optically in order to attain the function described above, thereby assembling the projection exposure apparatus in this embodiment.

[0073] Further, in accordance with the embodiment discussed above, the projection optical system 4 is constructed of the refractive optical member, and CaF_2 (calcium fluoride) is used for this optical member. In addition to or as a substitute for CaF_2 , the projection optical system 4 may be composed of a single kind of optical material, or plural kinds of optical materials by use of fluoride crystalline materials such as, e.g., barium fluoride, lithium fluoride and magnesium fluoride, and silica doped with fluoride. If capable of sufficiently narrowing the band of the illumination light illuminating the reticle R, however, it is preferable that the projection optical system 4 be composed of the single kind of optical material. Moreover, taking facilitation of manufacturing the projection optical system and manufacturing costs into consideration, it is preferable that the projection optical system 4 be consisting of only CaF_2 .

[0074] Note that the space throughout the optical path from the light source to the wafer is substituted by the helium gas in the embodiment discussed above, however, some proportion or all of the space along the optical path may be substituted by a nitrogen (N_2) gas, or a vacuum atmosphere may also be available.

[0075] Moreover, the light source involves the use of the F_2 laser, and the spectral width is narrowed by the band narrowing device. Instead, however, there may also be used higher harmonics of a solid-stage laser such as a YAG laser having an oscillation spectrum in 157 nm. Further, there may be used higher harmonics in which infrared band or visible band single wavelength laser beams oscillated from a DFB semiconductor laser or a fiber laser, are amplified a fiber amplifier into which, e.g., erbium (or both of erbium and yttrium) is doped, and are wavelength-converted into ultraviolet radiation by use of non-linear optical crystal.

[0076] Assuming that an oscillation wavelength of the single wavelength laser be within a range of, e.g., 1.51~1.59 μm , there are outputted tenth harmonic of which a wavelength occurred falls within a range of 151~159 nm. Supposing that especially the oscillation wavelength falls within a range of 1.57~1.58 μm , the tenth harmonic falling within the range of 157~158 nm, i.e., the ultraviolet radiation beams having substantially the same wavelength as that of the F_2 laser are obtained. Moreover, it is assumed that the oscillation wavelength be 1.03~1.12 μm , in which case there are outputted seventh harmonic of which the wavelength

occurred is within a range of 147~160 nm. Supposing that particularly the oscillation wavelength falls within a range of 1.099~1.106 μm , there are obtained the seventh harmonic of which the wavelength occurred is within the range of 157~158 nm, i.e., the ultraviolet radiation beams having substantially the same wavelength as that of the F_2 laser. Incidentally, a yttrium doped fiber laser is used as the single wavelength oscillation laser.

[0077] Thus, in the case of using the harmonics given from the laser light source, because of being the spectral width (e.g., on the order of 0.01 pm) with the band of the higher harmonics themselves being sufficiently narrowed, that may be used in place of the light source 1 and the band narrowing device 2 in the embodiment described above.

[0078] Now, the embodiment discussed above can be applied to both of a step-and-repeat method (a batch exposure method) in which after the pattern image of the reticle R has been batchwise transferred to one single shot area on the wafer W, the wafer is moved within the plane orthogonal to the optical axis of the projection optical system 4, and the next shot area is moved to the exposure area of the projection optical system, thus performing the exposure, and a step-and-scan method (a scan exposure method) in which the reticle R and the wafer W are synchronously scanned with a projection magnification β serving as a speed ratio with respect to the projection optical system 4 when exposing each shot area on the wafer W. Note that what is required of the step-and-scan method is just to obtain a preferable image forming characteristic within a slit-shaped exposure area, and it is therefore feasible to expose a much wider shot area on the wafer W without a scale-up of the projection optical system PL.

[0079] Incidentally, there may be used the projection optical systems of not only a reduction system but also an unit magnification system or an enlargement system (such as, e.g., an exposure apparatus for manufacturing a liquid crystal display). Furthermore, the present invention can be applied to, in addition to the exposure apparatus used for manufacturing the semiconductor device, an exposure apparatus used for manufacturing display devices including the liquid crystal display device, an exposure apparatus for transferring a device pattern onto a glass plate, an exposure apparatus used for manufacturing a thin-film magnetic head, an exposure apparatus for transferring the device pattern onto a ceramic wafer, and an exposure apparatus used for manufacturing an imaging device (CCD, etc.). The present invention can be also applied to an exposure apparatus for transferring a circuit pattern onto a glass substrate or a silicon wafer in order to manufacture a reticle or a mask.

[0080] It is to be noted that the present invention is not limited to the embodiment discussed above and may take a variety of configurations without deviating from the gist of the present invention within the scope of the invention.

[0081] As discussed above, according to the present embodiment, it is possible to provide the exposure apparatus having the high resolution enough to preferably correct the various aberrations containing the chromatic aberration by use of the light source having the wavelength shorter than 193 nm. It is also feasible to manufacture the preferable semiconductor device by use of this exposure apparatus.

What is claimed is:

1. A projection exposure apparatus for transferring a pattern on a projection original onto a photosensitive surface of a photosensitive substrate, comprising:

a light source;

an illumination optical system, disposed between said light source and said projection original, which illuminates a pattern on said projection original with a light beam emitted from said light source; and

a projection optical system, disposed between said projection original and said photosensitive substrate, which forms a pattern image on the photosensitive surface of said photosensitive substrate,

wherein said light source supplies light beams having a wavelength shorter than 193 nm,

said projection optical system includes a plurality of refractive optical elements, and

said refractive optical elements constituting said projection optical system are all composed of CaF_2 .

2. A projection exposure apparatus according to claim 1, further comprising a band narrowing device which narrows a band of a spectrum of light having the wavelength shorter than 193 nm, supplied from said light source.

3. A projection exposure apparatus according to claim 2, wherein said band narrowing device narrows a band of the light emitted from said light source to satisfy the following condition:

$$\Delta\lambda \leq 7.0 \times 10^{-13} \cdot L / \text{NA}^2$$

where $\Delta\lambda$ is a half-width of a spectrum of the light after the band thereof has been narrowed by said band narrowing device, L is a distance on the optical axis from a pattern surface on said projection original to the photosensitive surface of said photosensitive substrate, and NA is an image-side numerical aperture of said projection optical system.

4. A projection exposure apparatus according to claim 3, wherein said light source has an F_2 laser.

5. A projection exposure apparatus according to claim 1, wherein said illumination optical system guides the illumination light to said photosensitive substrate to satisfy the following condition:

$$\Delta\lambda \leq 7.0 \times 10^{-13} \cdot L / \text{NA}^2$$

where $\Delta\lambda$ is a half-width of a spectrum of the illumination light, L is a distance on the optical axis from a pattern surface on said projection original to the photosensitive surface of said photosensitive substrate, and NA is an image-side numerical aperture of said projection optical system.

6. A projection exposure apparatus according to claim 5, wherein said light source has an F_2 laser.

7. A projection exposure apparatus according to claim 1, wherein said light source has an F_2 laser.

8. A projection exposure apparatus according to claim 7, wherein a gas in an interior of said projection optical system includes helium gas.

9. A projection exposure apparatus according to claim 1, wherein said projection optical system is constructed of only refractive optical elements.

10. A projection exposure apparatus according to claim 1, wherein a gas in an interior of said projection optical system includes helium gas.

11. A projection exposure apparatus according to claim 1, wherein said projection optical system includes at least one positive lens and at least one negative lens.

12. A projection exposure apparatus for transferring a pattern on a projection original onto a photosensitive surface of a photosensitive substrate, comprising:

a light source;

an illumination optical system, disposed between said light source and said projection original, which illuminates a pattern on said projection original with a light beam emitted from said light source; and

a projection optical system, disposed between said projection original and said photosensitive substrate, which forms a pattern image on a photosensitive surface of said photosensitive substrate,

wherein said light source supplies light beams having a wavelength shorter than 193 nm, and said illumination optical system guides the illumination light to said projection original, the illumination light satisfying the following condition:

$$\Delta\lambda \leq 7.0 \times 10^{-13} \cdot L / NA^2$$

Where

$\Delta\lambda$: a half-width of a spectrum of the illumination,

L: a distance from a pattern surface on said projection original to the photosensitive surface of said photosensitive substrate; and

NA: a photosensitive-substrate-side numerical aperture of said projection optical system.

13. A projection exposure apparatus according to claim 12, further comprising a band narrowing device which narrows a band of a spectrum of light having a wavelength shorter than 193 nm, supplied from said light source.

14. A projection exposure apparatus according to claim 13, wherein said projection optical system is constructed of only refractive optical elements.

15. A projection exposure apparatus according to claim 12, wherein said projection optical system has refractive optical elements, and

said refractive optical elements are all composed of a single kind of optical material.

16. A projection exposure apparatus according to claim 15, wherein a gas in an interior of said projection optical system includes helium gas.

17. A projection exposure apparatus according to claim 12, wherein a gas in an interior of said projection optical system includes helium gas.

18. A projection exposure apparatus according to claim 12, wherein said projection optical system includes refractive optical elements, and

said refractive optical elements includes CaF_2 .

19. A projection exposure apparatus according to claim 18, wherein a gas in an interior of said projection optical system includes helium gas.

20. A projection exposure apparatus according to claim 12, wherein said projection optical system includes at least one positive lens and at least one negative lens.

21. A projection exposure apparatus comprising:

an illumination optical system which illuminates a pattern on a projection original with illumination light having a wavelength shorter than 193 nm; and

a projection optical system which forms a pattern image on a photosensitive surface of a photosensitive substrate,

wherein said illumination optical system supplies the illumination light having such a spectral width as to satisfy the following condition:

$$\Delta\lambda \leq 7.0 \times 10^{-13} \cdot L / NA^2$$

where $\Delta\lambda$ is a half-width of a spectrum of the illumination light given from said illumination optical system, L is a distance from a pattern surface on said projection original to the photosensitive surface of said photosensitive substrate, and NA is a photosensitive-substrate-side numerical aperture of said projection optical system, and

said projection optical system is constructed of refractive optical elements.

22. A projection exposure apparatus according to claim 21, wherein said all refractive optical elements in said projection optical system are consisting of a single kind of optical material.

23. A projection exposure apparatus according to claim 22, wherein said optical material is CaF_2 .

24. A projection exposure apparatus according to claim 23, wherein a gas in an interior of said projection optical system includes helium gas.

25. A projection exposure apparatus according to claim 22, wherein a gas in an interior of said projection optical system includes helium gas.

26. A projection exposure apparatus according to claim 21, wherein a gas in an interior of said projection optical system includes helium gas.

27. A projection exposure apparatus according to claim 21, wherein said illumination optical system has an F_2 laser.

28. A projection exposure apparatus according to claim 27, wherein all said refractive optical elements in said projection optical system are consisting of a single kind of optical material.

29. A projection exposure apparatus according to claim 27, wherein said illumination optical system includes a band narrowing device which narrows a band of a spectrum of the illumination light supplied by said F_2 laser.

30. A projection exposure apparatus according to claim 21, wherein said illumination optical system includes:

a light source; and

a band narrowing device which narrows a band of the spectrum of the illumination light supplied from said light source.

31. A projection exposure apparatus according to claim 21, wherein said illumination optical system includes a light source unit which supplies harmonic of a laser.

32. A projection exposure apparatus according to claim 21, wherein said projection optical system includes at least one positive lens and at least one negative lens.

33. A projection exposure apparatus comprising:

an illumination optical system which illuminates a pattern on a projection original with illumination light having a wavelength shorter than 193 nm; and

a projection optical system which forms a pattern image on a photosensitive surface of a photosensitive substrate,

wherein said illumination optical system supplies the illumination light having such a spectral width that a Strehl intensity on an image surface of said projection optical system is 0.8 or larger.

34. A projection exposure apparatus according to claim 33, wherein optical elements in said projection optical system consisting of only refractive optical elements.

35. A projection exposure apparatus according to claim 34, wherein said refractive optical elements consisting of a single kind of optical material.

36. A projection exposure apparatus according to claim 35, wherein said single kind of material is CaF_2 .

37. A projection exposure apparatus according to claim 34, wherein a gas in an interior of said projection optical system includes helium gas.

38. A projection exposure apparatus according to claim 34, wherein said illumination optical system supplies the illumination light having such a spectral width as to satisfy the following condition:

$$\Delta\lambda \leq 7.0 \times 10^{-13} \cdot L / \text{NA}^2$$

where $\alpha\lambda$ is a half-width of a spectrum of the illumination light, L is a distance from a pattern surface on said projection original to the photosensitive surface of said photosensitive substrate, and NA is a photosensitive-substrate-side numerical aperture of said projection optical system.

39. A projection exposure apparatus according to claim 38, wherein said illumination optical system includes:

a light source which supplies the light having a wavelength shorter than 193 nm; and

a band narrowing device which narrows a band of a light beam supplied from said light source.

40. A projection exposure apparatus according to claim 33, wherein said illumination optical system includes a light source unit which supplies harmonic of a laser.

41. A projection exposure apparatus according to claim 33, wherein said illumination optical system includes an F_2 laser.

42. A projection exposure apparatus according to claim 41, wherein a gas in an interior of said projection optical system includes helium gas.

43. A projection exposure apparatus according to claim 41, wherein said projection optical system includes refractive optical elements, and

all said refractive optical elements consisting of CaF_2 .

44. A projection exposure apparatus according to claim 41, wherein said projection optical system includes refractive optical elements, and

said refractive optical elements includes CaF_2 .

45. A projection exposure apparatus according to claim 33, wherein a gas in an interior of said projection optical system includes helium gas.

46. A projection exposure apparatus according to claim 33, wherein said projection optical system includes at least one positive lens and at least one negative lens.

47. A projection exposure method comprising:

a step of supplying illumination light having a wavelength shorter than 193 nm;

a step of guiding the illumination light to a projection original having a predetermined pattern and illuminating said projection original with the illumination light; and

a step of forming a pattern image on a photosensitive surface of a photosensitive substrate by a projection optical system including a plurality of refractive optical elements,

wherein all said refractive optical elements in said projection optical system consisting of CaF_2 .

48. A projection exposure method according to claim 47, wherein a half-width $\Delta\lambda$ of a spectrum of the illumination light in said illuminating step is set by:

$$\Delta\lambda \leq 7.0 \times 10^{-13} \cdot L / \text{NA}^2$$

where

L: a distance on the optical axis from a pattern surface on said projection original to the photosensitive surface of said photosensitive substrate, and

NA: an image-side numerical aperture of said projection optical system.

49. A projection exposure method according to claim 48, wherein laser beams from an F_2 laser are supplied in said illumination light supplying step.

50. A projection exposure method according to claim 47, wherein laser beams from an F_2 excimer laser are supplied in said illumination light supplying step.

51. A projection exposure method according to claim 47, further comprising a step of narrowing a band of a spectrum of the illumination light.

52. A projection exposure method according to claim 47, wherein the illumination light transmits a space filled with helium gas, in said image forming step.

53. A device manufacturing method comprising:

a step of preparing a projection original formed with a circuit pattern;

a step of preparing a photosensitive substrate; and a step of transferring the circuit pattern formed on said projection original onto said photosensitive substrate by use of said projection exposure method according to claim 47.

54. A projection exposure method comprising:

a step of supplying the illumination light of which a wavelength is shorter than 193 nm;

a step of illuminating a pattern on a projection original with the illumination light; and

a step of projecting a pattern image to a photosensitive substrate by use of a projection optical system,

wherein said illuminating step comprises supplying the illumination light having such a spectral width as to satisfy the following condition:

$$\Delta\lambda \leq 7.0 \times 10^{-13} \cdot L / \text{NA}^2$$

where $\Delta\lambda$ is a half-width of a spectrum of the illumination light given from said illumination optical system, L is a distance from a pattern surface on said projection original to the photosensitive surface of said photosensitive substrate, and NA is a photosensitive-substrate-side numerical aperture of said projection optical system, and

said projecting step comprises guiding the light from said projection original to said photosensitive substrate via refractive optical elements.

55. A projection exposure method according to claim 54, wherein said projecting step comprises guiding the light from said projection original to said photosensitive substrate via only said refractive optical elements.

56. A projection exposure method according to claim 55, wherein laser beams from an F₂ laser are supplied in said illumination light supplying step.

57. A projection exposure apparatus according to claim 55, wherein said refractive optical elements consisting of a single kind of optical material.

58. A projection exposure method according to claim 57, wherein said optical material is CaF₂.

59. A projection exposure method according to claim 55, wherein said illumination light supplying step includes a sub-step of narrowing the band of the spectrum of the light supplied.

60. A projection exposure method according to claim 59, wherein the light from an F₂ laser is supplied in said illumination light supplying step.

61. A projection exposure method according to claim 60, wherein said illumination light supplying step includes a first sub-step of supplying laser beams having a predetermined wavelength, and a second sub-step of converting the laser beams into harmonics having a wavelength shorter than 193 nm.

62. A projection exposure method according to claim 54, wherein the light from an F₂ laser is supplied in said illumination light supplying step.

63. A projection exposure method according to claim 54, wherein said illumination light supplying step includes a sub-step of narrowing the band of the spectrum of the light supplied.

64. A projection exposure method according to claim 54, wherein the illumination light transmits a space filled with helium gas, in said projecting step.

65. A device manufacturing method comprising:

a step of preparing a projection original formed with a circuit pattern;

a step of preparing a photosensitive substrate; and

a step of transferring the circuit pattern formed on said projection original onto said photosensitive substrate by use of said projection exposure method according to claim 54.

66. A projection exposure apparatus comprising:

a step of supplying illumination light having a wavelength shorter than 193 nm;

a step of illuminating a pattern on a projection original with the illumination light; and

a step of projecting a pattern image on a photosensitive substrate by use of a projection optical system,

wherein said illumination light supplying step comprises supplying the illumination light having such a spectral width that a Strehl intensity on an image surface of said projection optical system is 0.8 or larger.

67. A projection exposure method according to claim 66, wherein said illuminating step comprises supplying the illumination light having such a spectral width as to satisfy the following condition:

$$\Delta\lambda \leq 7.0 \times 10^{-13} \cdot L / NA^2$$

where $\Delta\lambda$ is a half-width of a spectrum of the illumination light given from said illumination optical system, L is a distance from a pattern surface on said projection original to the photosensitive surface of said photosensitive substrate, and NA is a photosensitive-substrate-side numerical aperture of said projection optical system.

68. A projection exposure method according to claim 67, wherein the light from an F₂ laser is supplied in said illuminating step.

69. A projection exposure method according to claim 66, wherein the light from an F₂ laser is supplied in said illuminating step.

70. A projection exposure method according to claim 69, wherein the illumination light transmits a space filled with helium gas, in said projecting step.

71. A projection exposure method according to claim 69, wherein said projecting step comprises guiding the light from said projection original to said photosensitive substrate via said refractive optical elements consisting of CaF₂.

72. A projection exposure method according to claim 69, wherein said projecting step comprises guiding the light from said projection original to said photosensitive substrate via only said refractive optical elements consisting of CaF₂.

73. A projection exposure method according to claim 66, wherein said projecting step comprises guiding the light from said projection original to said photosensitive substrate via only said refractive optical elements.

74. A projection exposure method according to claim 73, wherein said illuminating step comprises supplying the illumination light having such a spectral width as to satisfy the following condition:

$$\Delta\lambda \leq 1.27 \times 10^{-13} \cdot L / NA^2$$

where $\Delta\lambda$ is a half-width of a spectrum of the illumination light given from said illumination optical system, L is a distance from a pattern surface on said projection original to the photosensitive surface of said photosensitive substrate, and NA is a photosensitive-substrate-side numerical aperture of said projection optical system.

75. A device manufacturing method comprising:

a step of preparing a projection original formed with a circuit pattern;

a step of preparing a photosensitive substrate; and

a step of transferring the circuit pattern formed on said projection original onto said photosensitive substrate by use of said projection exposure method according to claim 66.

76. A method of manufacturing a projection exposure apparatus, comprising:

a step of preparing an illumination optical system which illuminates a pattern on a projection original with illumination light having a wavelength shorter than 193 nm; and

a step of preparing a projection optical system which forms a pattern image on a photosensitive surface of a photosensitive substrate by a projection optical system,

wherein said illumination optical system is constructed to supply the illumination light having such a spectral width as to satisfy the following condition:

$$\Delta\lambda \leq 7.0 \times 10^{-13} \cdot L / NA^2$$

where $\Delta\lambda$ is a half-width of a spectrum of the illumination light given from said illumination optical system, L is a distance from a pattern surface on said projection original to the photosensitive surface of

said photosensitive substrate, and NA is a photosensitive-substrate-side numerical aperture of said projection optical system,

said projection optical system preparing step includes a sub-step of preparing a plurality of refractive optical elements, and a sub-step of assembling said plurality of refractive optical elements, and said method further comprises a step of assembling said illumination optical system and said projection optical system.

77. A projection exposure method according to claim 47, wherein said projection optical system having a catadioptric system.

78. A projection exposure method according to claim 54, wherein said projection optical system having a catadioptric system.

79. A projection exposure method according to claim 66, wherein said projection optical system having a catadioptric system.

* * * * *