

*H. Brown,  
Band Saw Mill.*

*N<sup>o</sup> 18,570.*

*Patented Nov. 10, 1857.*

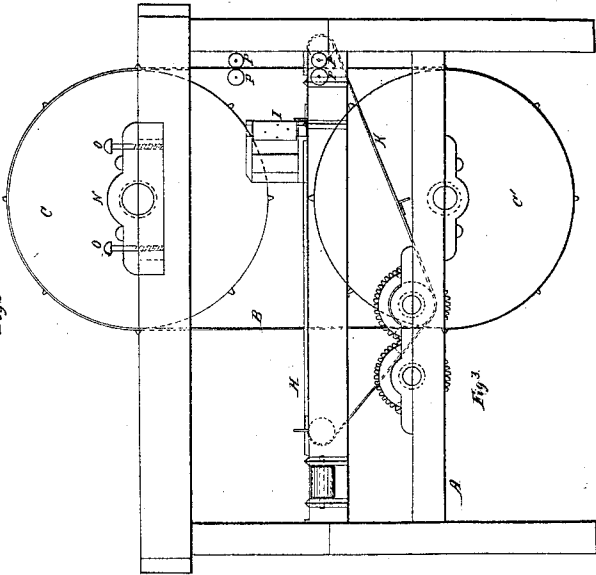
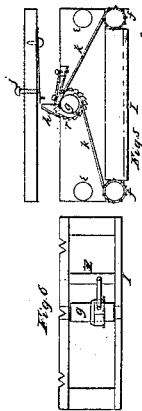
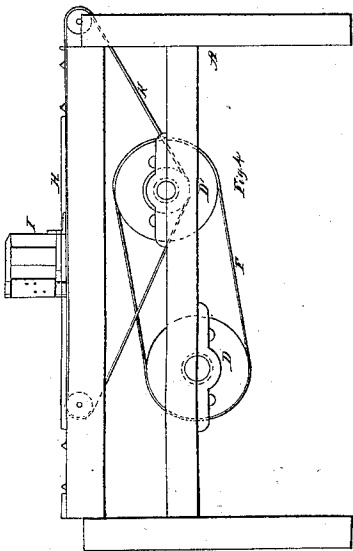
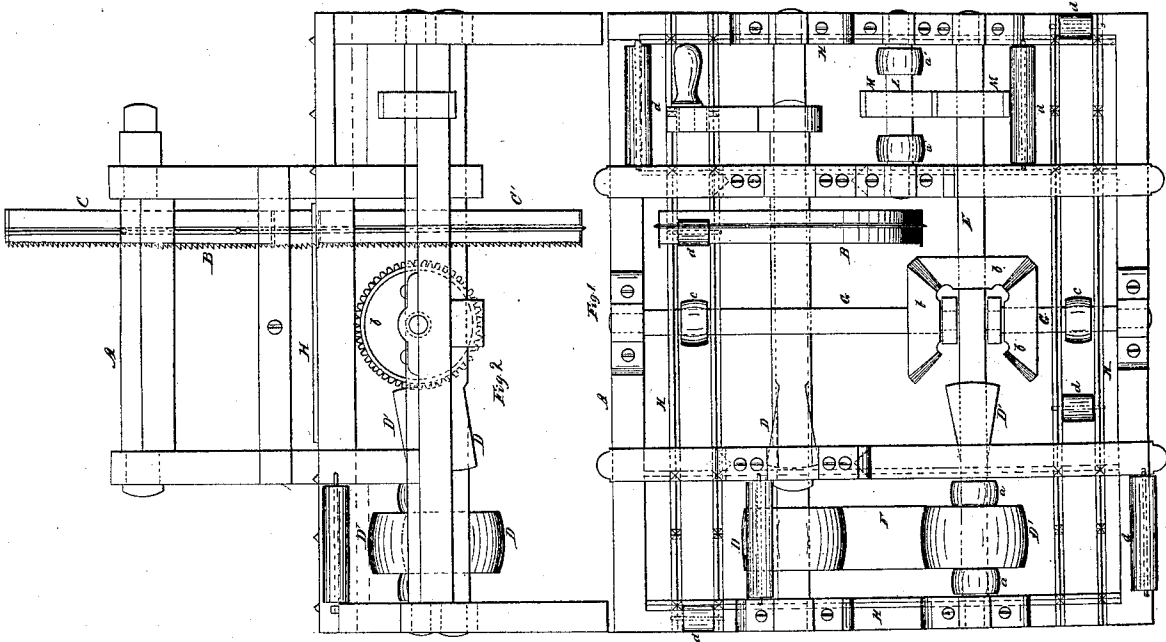

# UNITED STATES PATENT OFFICE.

HARVEY BROWN, OF NEW YORK, N. Y.

## SAWING-MACHINE.

Specification of Letter's Patent No. 18,570, dated November 10, 1857.

*To all whom it may concern:*

Be it known that I, HARVEY BROWN, of the city, county, and State of New York, have invented a new and Improved Sawmill for Sawing Any Description of Lumber from Logs, Cants, or Otherwise; and I do hereby declare that the following is a full and exact description thereof, reference being had to the annexed drawings, making a part of this specification, in which—

Figure 1, is a perspective view or ground plan; Fig. 2, a longitudinal elevation; Fig. 3, a transverse view; Fig. 4, a reverse view of Fig. 3; Fig. 5, a perspective view or ground plan of one of the carriages; Fig. 6, a transverse view of Fig. 5; A, the frame of the machine or mill; B, the saw mounted upon the pulleys, C, C'; D, D', the driving pulleys; E, the counter shaft; F, the principal driving band; G, G, the transverse shafts; H, the ways; I, the carriages; K, the bands that move the carriages; L, a second counter shaft; M, the cog wheels connecting the shafts E, L; N, the plumber blocks; P, slides or friction rollers.

To enable others skilled in the art to make and use my invention I will proceed to describe its construction and operation.

I make a frame, A, proportioned in size and parts to the work to be performed, to which I attach the shafts bearing the pulleys, C, C', upon which the saw, B, is mounted. To the shaft, C, is attached the crank pulley or cog wheel for driving the machine or sawmill by any motive power desired. This arrangement for driving can be attached to either of the saw pulley shafts, to the driving pulleys marked, D, (straight and cone either at selection) to move the band F in connection with corresponding pulleys marked, D', on the counter shaft, E. To this counter shaft are attached pulleys, *a, a*, and to another shaft, L, attached to the counter shaft E by the cog wheels, M, M, is attached pulleys, *a', a'*, and also the transverse shafts, G, G, are attached to the bevel cog wheels, *b, b, b*, and to these transverse shafts are attached pulleys, *c, c*. Above this arrangement of gearing and within the frame of my mill I attach the ways H, upon which the carriages, I, I, are moved bearing the logs or timber to be sawed. These ways are made a parallelogram or long square varying according to the carriage or log to be sawed. They have outer and inner parallel bars connected at right angles. At the proper dis-

tances between these bars are placed pulleys *d, d, d, d, d, d, d, d*. The carriages I I (six in the model; the arrangement can be made for any number and to run inside or outside of the saw, as preferred) are made with a bed piece, in the under side of which the grooves are cut by which they are attached to and move on the bars of the ways, H, by means of the bands, K, having projections on them, moved by the pulleys, *a, a*, on the counter shaft; *a' a'* on the second counter shaft, and *c, c*, on the transverse shafts, over the pulleys *d, d, d, d, d, d, d, d*. The carriages have a top piece likewise and are connected by means of the pillars, *e, e, e*. At each end of the carriages are revolving dogs, *f*, connected with the pulley, *g*, by means of cords or chains, *h*, in such a manner as that when the log being prepared the right length and placed on the carriage between the dogs, *f*, the mill being in motion brings the carriage forward on the ways, H, until the pawl, *h*, (to which there is attached a ratchet wheel, *r*, and dogs for the purpose of moving and holding the pulley, *g*, to which it is attached) is brought in contact with the projection, *i*, by which means the pulley, *g*, is moved to the extent the projection, *i*, is in contact with the pawl, *h*, consequently by means of the cords or chains, *h*, the dogs *f* are moved in the same proportion, this arrangement constituting an exact principle of setting the log to the saw to make boards or planks of uniform thickness by means of the set screws, *j*, which operate upon the projection, *i*, at the will of the operator.

In constructing my saw, B, I make it of steel having holes in it at certain distances adapted to the circuit or length of my saw and the diameter of the pulleys over which it is to run, and in the pulleys I place projecting bolts or pins at such distances precisely to correspond with and meet the holes in the saw, and thus placing the saw on the pulleys, by means of the plumber block, N, and the set screws, O, passing the plumber blocks. I strain the saw to a suitable tension to perform its work. For the purpose of guiding the saw, I place friction rollers, P, next to the saw above and below where it passes through the log.

My mill in its operation is an endless saw receiving logs or timber to be sawed on successive carriages running on endless ways, and each log upon its carriage as it passes

the projection, *i*, is set uniformly and thus the logs properly placed upon the carriages and the several parts of the mill in proper order. The whole of the logs are cut up  
 5 without further labor of the operator, having only to remove the boards when sawed off, which is done with great rapidity.

The advantages of this mill must be obvious to any observer.

10 I do not claim a saw or band running over pulleys without reference to its construction and operation.

I claim—

15 1. The ways, *H*, constructed substantially in the manner and for the purposes as herein set forth.

2. I claim the arrangement of gearing for the purpose of moving the carriages, *I, I, I, I, I, I*, on the ways *H* substantially as  
 20 set forth.

3. I claim the pulley, *g*, with its appendages of the pawl, *h*, and ratchet wheel, *r*, in

connection with the projection, *i*, and the dogs, *f*, by means of the cords or chains, *k*, substantially in the manner and for the  
 25 purposes described.

I do not claim the projection, *i*, the dogs, *f*, or the chains, *k*, separately as they are not new and may be altered in their form in my mill and so used in connection with the pulley, *g*, and its appendage which is my claim  
 30 as above.

4. I claim the entire arrangement of my mill by which a series of carriages are brought forward on endless ways to an endless saw, and each log upon its carriage being accurately set as it passes the projection, *i*, and thereby securing accuracy, rapidity and efficiency substantially in the manner and for the purposes set forth.  
 35

HARVEY BROWN.

Witnesses:

WILLIAM T. GRAFF,  
 R. H. CUDLIPP.