

(12) STANDARD PATENT
(19) AUSTRALIAN PATENT OFFICE

(11) Application No. **AU 2018257648 B2**

(54) Title
Field serviceable and replaceable assembly

(51) International Patent Classification(s)
G02B 26/00 (2006.01) **H04N 5/64** (2006.01)
G06F 1/16 (2006.01) **H05K 5/00** (2006.01)
G09G 3/34 (2006.01) **H05K 7/20** (2006.01)
H01J 7/24 (2006.01)

(21) Application No: **2018257648** (22) Date of Filing: **2018.04.17**

(87) WIPO No: **WO18/200260**

(30) Priority Data

(31) Number	(32) Date	(33) Country
62/491,106	2017.04.27	US
15/886,889	2018.02.02	US
15/723,311	2017.10.03	US
62/502,337	2017.05.05	US
15/647,219	2017.07.11	US

(43) Publication Date: **2018.11.01**

(44) Accepted Journal Date: **2020.10.22**

(71) Applicant(s)
Manufacturing Resources International, Inc.

(72) Inventor(s)
Dunn, William;O'Connor, Kevin;Diaz, Marcos

(74) Agent / Attorney
Spruson & Ferguson, Level 24, Tower 2 Darling Park, 201 Sussex Street, Sydney, NSW, 2000, AU

(56) Related Art
US 20170083043 A1



(51) International Patent Classification:

G02B 26/00 (2006.01) H04N 5/64 (2006.01)

G06F 1/16 (2006.01) H05K 5/00 (2006.01)

G09G 3/34 (2006.01) H05K 7/20 (2006.01)

H01J 7/24 (2006.01)

(21) International Application Number:

PCT/US2018/027970

(22) International Filing Date:

17 April 2018 (17.04.2018)

(25) Filing Language:

English

(26) Publication Language:

English

(30) Priority Data:

62/491,106 27 April 2017 (27.04.2017) US

62/502,337 05 May 2017 (05.05.2017) US

15/647,219 11 July 2017 (11.07.2017) US

15/723,311 03 October 2017 (03.10.2017) US

15/886,889 02 February 2018 (02.02.2018) US

(71) Applicant: **MANUFACTURING RESOURCES INTERNATIONAL, INC.** [US/US]; 6415 Shiloh Road East, Alpharetta, GA 30005 (US).

(72) Inventors: **DUNN, William**; 6415 Shiloh Road East, Alpharetta, GA 30005 (US). **O'CONNOR, Kevin**; 6415

Shiloh Road East, Alpharetta, GA 30005 (US). **DIAZ, Marcos**; 6415 Shiloh Road East, Alpharetta, GA 30005 (US).

(74) Agent: **SMITH, Adam J.** et al.; Standley Law Group LLP, 6300 Riverside Drive, Dublin, OH 43017 (US).

(81) Designated States (*unless otherwise indicated, for every kind of national protection available*): AE, AG, AL, AM, AO, AT, AU, AZ, BA, BB, BG, BH, BN, BR, BW, BY, BZ, CA, CH, CL, CN, CO, CR, CU, CZ, DE, DJ, DK, DM, DO, DZ, EC, EE, EG, ES, FI, GB, GD, GE, GH, GM, GT, HN, HR, HU, ID, IL, IN, IR, IS, JO, JP, KE, KG, KH, KN, KP, KR, KW, KZ, LA, LC, LK, LR, LS, LU, LY, MA, MD, ME, MG, MK, MN, MW, MX, MY, MZ, NA, NG, NI, NO, NZ, OM, PA, PE, PG, PH, PL, PT, QA, RO, RS, RU, RW, SA, SC, SD, SE, SG, SK, SL, SM, ST, SV, SY, TH, TJ, TM, TN, TR, TT, TZ, UA, UG, US, UZ, VC, VN, ZA, ZM, ZW.

(84) Designated States (*unless otherwise indicated, for every kind of regional protection available*): ARIPO (BW, GH, GM, KE, LR, LS, MW, MZ, NA, RW, SD, SL, ST, SZ, TZ, UG, ZM, ZW), Eurasian (AM, AZ, BY, KG, KZ, RU, TJ, TM), European (AL, AT, BE, BG, CH, CY, CZ, DE, DK, EE, ES, FI, FR, GB, GR, HR, HU, IE, IS, IT, LT, LU, LV, MC, MK, MT, NL, NO, PL, PT, RO, RS, SE, SI, SK, SM, TR), OAPI (BF, BJ, CF, CG, CI, CM, GA, GN, GQ, GW, KM, ML, MR, NE, SN, TD, TG).

(54) Title: FIELD SERVICEABLE AND REPLACEABLE ASSEMBLY

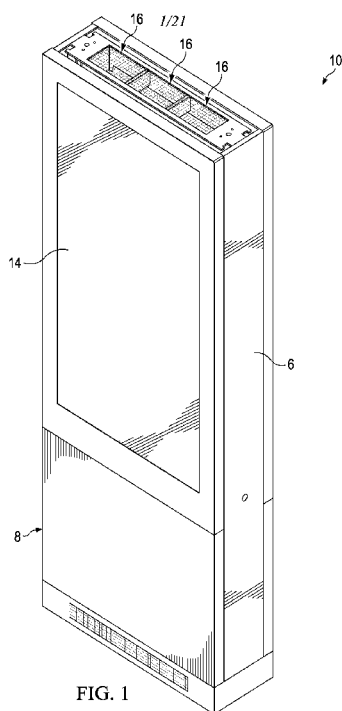

FIG. 1

(57) Abstract: A field serviceable assembly includes a first and second side assembly (14) hingedly mounted to a frame (12) in a back to back arrangement. At least one of the side assemblies (14) has a cover panel (17), an electronic display (11), a first channel (25) that receives circulating gas (36), and a second channel (23) that receives ambient air (38). A cavity (18) is located in the space between the rear surfaces of the side assemblies (14) and the frame (12) and contains an electronics plate (42) for receiving electronic components (30/44). The cavity (18) and the first channel (25) are part of a closed loop pathway, while the second channel (23) is part of an open loop pathway.



Published:

— *with international search report (Art. 21(3))*

FIELD SERVICEABLE AND REPLACEABLE ASSEMBLY

CROSS-REFERENCE TO RELATED APPLICATION

[0001] This application claims the benefit of U.S. Provisional Patent Application Serial No. 62/491,106 filed April 27, 2017, U.S. Provisional Patent Application Serial No. 62/502,337 filed May 5, 2017, U.S. Non-Provisional Patent Application Serial No. 15/647,219 filed July 11, 2017, U.S. Non-Provisional Patent Application Serial No. 15/723,311 filed October 3, 2017, and U.S. Non-Provisional Patent Application Serial No. 15/886,889 filed February 2, 2018. The disclosures of all of which are hereby incorporated by reference in their entireties.

TECHNICAL FIELD

[0002] Exemplary embodiments of the present invention relate generally to assemblies for electronic displays.

BACKGROUND AND SUMMARY OF THE INVENTION

[0003] Electronic displays have grown in popularity not only for indoor use, but also for outdoor use. One exemplary application, without limitation, is the digital out of home advertising market where the electronic displays are increasingly replacing the use of static posters. The use of electronic displays is advantageous because they allow images to be changed quickly as well as permit the use of videos and interactive displays, among other benefits. Such displays have been placed in many locations, including but not limited, on billboards, the tops of vehicles, bus shelters, kiosks, sidewalks, stadiums, buildings, and the like.

[0004] Such outdoor, and some indoor, displays are often encased in a housing to protect them from environmental conditions and to hold various electronic components that are used to operate the displays. Despite efforts to protect the display from environmental conditions and other potential hazards, failures of the displays themselves and their related electronic components do occur. When such failures occur, it is often necessary to repair, replace, or otherwise service (hereinafter also collectively, “servicing” or “service”) the displays themselves or their various electronic components. Even when such failures have not occurred, it may be desirable to access the displays or the various electronic components thereof to perform routine or preventative maintenance, or simply for inspection purposes. It may also be desirable to provide a sealed, powered, connected, and/or cooled cavity for electronic equipment. Finally, it may be desirable to change the configuration of the assembly. For example, without limitation, it may be

desirable to convert a double sided electronic display into an electronic display on one side with a static poster display on the other. Current assemblies for electronic displays make it difficult or impossible to service the display and the related electronic components. Therefore, what is needed is a field serviceable and replaceable assembly for an electronic display.

[0005] Further, such assemblies are generally connected to external power sources and communications networks. Such connections often require interaction with utility lines. Interaction with these utility lines generally subjects any servicing work to additional regulations and requires technicians having specialized knowledge. Such efforts generally increase the costs, time, and effort involved with such servicing. Therefore, what is needed is a field serviceable and replaceable assembly for an electronic display.

[0005a] It is an object of the present invention to meet this need or to substantially overcome, or at least ameliorate, one or more disadvantages of existing arrangements.

[0005b] In a first aspect, the present invention provides a field serviceable assembly comprising: a frame; a first and second side assembly, each having a rear surface and being moveably mounted to the frame in a back to back arrangement, wherein at least one of the side assemblies comprises: a cover panel; an electronic display located behind the cover panel; a backlight located behind the electronic display; a first channel configured to receive circulating gas; and a second channel configured to receive ambient air; a cavity located between the rear surfaces of the first and second side assemblies and the frame; an electronics plate positioned within the cavity and configured to receive a plurality of electronic components, wherein said electronics plate is configured to remain stationary when said first and second side assemblies are moved between said opened position and said closed position, wherein movement into said opened position exposes said electronics plate to facilitate access to said electronic components located thereon; a closed loop pathway comprising said cavity and said first channel; a first open loop pathway comprising said second channel of said first side assembly; and a second open loop pathway comprising said second channel of said second side assembly.

[0005c] In a second aspect, the present invention provides a field serviceable assembly comprising: a frame comprising a top panel, a right side panel, a left side

panel, and a bottom panel, said panels being interconnected to form a substantially rectangular shape; a first side assembly movably mounted to the frame and comprising: a transparent layer; an electronic display positioned behind said transparent layer; a first channel configured to receive circulating gas and located between said transparent layer and said electronic display; a second channel configured to receive a first flow of ambient air, wherein said second channel is positioned behind said electronic display; a second side assembly moveably mounted to the frame and positioned in a back to back arrangement with said first side assembly, said second side assembly comprising: a cover; a plate spaced apart from, and positioned substantially parallel to, said cover; and a third channel located between said cover and said plate, wherein said third channel is configured to receive a second flow of ambient air; a number of hinges, each of which are connected to the frame and one or both of the first and second side assemblies and are configured to facilitate movement of said first and second side assemblies between an opened position and a closed position; a cavity located between the first and second side assemblies and the frame, wherein said cavity is configured to receive circulating gas from said first channel; and an electronics plate positioned within the cavity between, spaced apart from, and substantially parallel to rear surfaces of the first and second side assemblies, wherein said electronics plate is configured to remain stationary when said first and second side assemblies are moved between said opened position and said closed position, wherein said electronics plate is configured to receive a plurality of electronic components, and wherein movement into the opened position facilitates access to the electronic components installed at said fixed plate.

[0005d] In a third aspect, the present invention provides a field serviceable assembly comprising: a frame having a substantially rectangular shape and comprising a first and second frame hinge plate located on opposing sides of said frame; a first and second side assembly rotatably mounted to the frame in a back to back arrangement such that each of the first and second side assemblies may be rotated outwardly along a substantially horizontal axis, wherein each of said first and second side assemblies comprises: a transparent layer; an electronic display located behind the transparent layer; a backlight located behind the electronic display; a corrugation layer located between the backlight and a rear surface of the side assembly, wherein the corrugation layer is configured to receive ambient air; and a channel located between the transparent layer and the electronic display, wherein the first channel is configured to

receive circulating gas; a shared cavity defined by the space between the rear surfaces of the first and second side assemblies and the frame, wherein said shared cavity is in gaseous communication with each of the front channels; and a server rack positioned within the cavity and configured to interchangeably receive any of a plurality of electronic components, wherein said server rack is configured to remain stationary when said first and second side assemblies are rotated between an opened position and a closed position, wherein movement into said opened position exposes said server rack to facilitate access to said electronic components located thereon.

[0006] The present disclosure describes a field serviceable and replaceable assembly for an electronic display. A single side assembly or a back-to-back pair of side assemblies may be hingedly mounted to a frame. More specifically, the side assembly may comprise a frame configured to receive, in a back to back configuration, one or more digital displays, one or more covers, one or more poster holders (illuminated or not illuminated), or some combination thereof. A closed loop of circulating gas and an open loop of ambient air may flow through the assembly. The frame may be surrounded, at least in part, by a housing. In exemplary embodiments utilizing back-to-back side assemblies, the frame and the side assemblies may enclose an electronics cavity. Each side assembly may be hingedly connected to an upper portion of the frame and may be configured to swing outwardly to allow access to electronic components located in an electronics cavity. The cavity may be sealed, cooled, powered, and/or connected for electronic equipment. Some electronic components may be mounted to a plate located between the two side assemblies. In other embodiments, the plate (along with the electronic components) may be mounted to one of the side assemblies or may form a part of the respective side assembly.

[0007] In exemplary embodiments utilizing a single side assembly, the side assembly may be similarly mounted. However, an access panel may enclose the rear of the assembly such that the electronics cavity may also be accessed from the rear. The access panel may additionally be configured to receive a poster or a cover.

[0008] Regardless, a pair of aid devices may be utilized with each side assembly or access panel to assist in moving the side assembly between the open and the close position as well as secure the side assembly in the open or closed position. In

exemplary embodiments, a number of the electronic components may be shared for both side assemblies so as to reduce the total number of electronic components required. The aid devices may also assist in securing the side assembly in the open or the closed position. The side assemblies and/or the access panel may be opened to service the electronic components and the side assemblies. When necessary, the side assembly itself may be removed from the frame and replaced.

[0009] The one or more digital displays, one or more covers, and one or more poster holders may be mechanically attached to the frame by way of a bracket and a pin, which may be configured to serve as the main, or only, mechanical support for the one or more digital displays, one or more covers, and one or more poster holders. In this way, the digital displays, covers, or poster holders may be easily and quickly removed from the frame for servicing. In exemplary embodiments, external power and communications connections may be located on the frame or on a plate located between the one or more digital displays, one or more covers, one or more poster holders such that servicing of the one or more digital displays, one or more covers, one or more poster holders can be performed by disconnecting the power and communications at the connection point rather than disturbing the connection to the utility lines. In this way, the external power and communications connections may often remain undisturbed.

[0010] In some situations, it may be advantageous to increase the cooling capabilities of the assembly. For example, without limitation, it may be desirable to add additional temperature sensitive or heat producing equipment to the assemblies, drive the electronic displays or illumination elements at higher brightness levels, operate in extreme environments with high temperatures or high solar loading, or to provide and operate larger electronic displays in one or more of the side assemblies. Therefore, what is needed is a field serviceable and replaceable assembly for an electronic display with increased cooling.

[0011] The present disclosure provides a field serviceable and replaceable assembly for an electronic display with increased cooling. In exemplary embodiments, an additional open loop channel for ambient air may be added to one or both of the side assemblies mounted to either side of the frame. In exemplary embodiments, the additional open loop channel may only be added to the side assembly or assemblies

comprising a cover or a poster holder, though it is contemplated that the additional open loop channel may also be added to the side assemblies comprising a digital display. It is

contemplated that the additional open loop channel may be added to one or both side assemblies.

BRIEF DESCRIPTION OF THE DRAWINGS

[0012] In addition to the features mentioned above, other aspects of the present invention will be readily apparent from the following descriptions of the drawings and exemplary embodiments, wherein like reference numerals across the several views refer to identical or equivalent features, and wherein:

[0013] **Figure 1** is a front perspective view of an exemplary assembly in accordance with the present invention;

[0014] **Figure 2** is a front perspective of the assembly of figure 1 illustrated with the stand removed to illustrate additional components of the assembly;

[0015] **Figure 3** is a front perspective of the assembly of figure 2 illustrated with one of the assemblies in the open position;

[0016] **Figure 4** is a front perspective view of the assembly of figure 2 illustrated with one of the assemblies removed;

[0017] **Figure 5** is a front perspective view of the assembly of figure 4, illustrated with exemplary flow paths for circulating gas and ambient air;

[0018] **Figure 6** is a top sectional view of an exemplary display assembly illustrated in isolation from other components to illustrate exemplary flow paths for circulating gas and ambient air;

[0019] **Figure 7** is a front perspective view of another exemplary embodiment of the assembly also indicating section lines A-A and B-B;

[0020] **Figure 8** is a front perspective view of the assembly of figure 7 illustrated with both display assemblies in the open position;

[0021] **Figure 9** is an exploded front perspective view of the assembly of figure 8;

[0022] **Figure 10** is a top sectional view taken along section line A-A of figure 7;

[0023] **Figure 11** is a side sectional view taken along section line B-B of figure 7;

[0024] **Figure 12A** is a rear perspective view of another exemplary assembly;

[0025] **Figure 12B** is a rear perspective view of another exemplary assembly;

[0026] **Figure 13** is a front perspective view of another exemplary assembly also indicating Detail A;

[0027] **Figure 14** is a front perspective view of the assembly of figure 13 illustrated with one of the display assemblies in the open position;

[0028] **Figure 15** is a rear perspective view of the assembly of figure 13 illustrated with both of the display assemblies in the open position also indicating Detail B;

[0029] **Figure 16** is a front perspective view of the assembly of figure 14 illustrated with one of the display assemblies removed;

[0030] **Figure 17** is a detailed top perspective view of Detail A of figure 13;

[0031] **Figure 18A** is a detailed perspective view of Detail B of figure 15 with the display assembly in the closed position and illustrating an otherwise hidden strut;

[0032] **Figure 18B** is a detailed top perspective view of the assembly of figure 18A illustrated with the display assembly in the open position;

[0033] **FIGURE 19A** is a vertical cross-sectional view of another exemplary assembly;

[0034] **FIGURE 19B** is a vertical cross-sectional view of another exemplary assembly; and

[0035] **Figure 20** is a horizontal cross-sectional view of the assembly of figure 19A.

DETAILED DESCRIPTION OF EXEMPLARY EMBODIMENT(S)

[0036] Various embodiments of the present invention will now be described in detail with reference to the accompanying drawings. In the following description, specific details such as detailed configuration and components are merely provided to assist the overall understanding of these embodiments of the present invention. Therefore, it should be apparent to those skilled in the art that various changes and modifications of the embodiments described herein can be made without departing from the scope and spirit of the present invention. In addition, descriptions of well-known functions and constructions are omitted for clarity and conciseness.

[0037] **Figure 1** is a front perspective view of an exemplary assembly 10 in accordance with the present invention. The assembly 10 may comprise one or more side assemblies 14 placed within a housing 6. The housing 6 may comprise a stand 8 for mounting the assembly 10 to the ground. However, in other exemplary embodiments, the assembly 10 may be mounted to another object such as, but not limited to, a bus shelter, a post, a wall, a building, a roof rack for a vehicle, or the like. Regardless, an intake 16 may be located on the top of the housing 6. As will be described in greater detail herein, an exhaust 9 may be located on the bottom of the housing 6. However, it is contemplated that the intake 16 may be located on the bottom of the housing 6 with the exhaust 9 being located on the top of the housing 6. Any other location for the intake 16 and the exhaust 9 is contemplated. Regardless, the intake 16 may likewise extend through the frame 12.

Similarly, the exhaust 9 may extend through the frame 12. Alternatively, the air may flow into the exhaust 9 and out of the intake 16.

[0038] **Figure 2** is a front perspective of the assembly 10 of figure 1 illustrated with the stand 6 removed to illustrate additional components of the assembly 10. The side assemblies 14 may be mounted to a frame 12. The frame 12 may be substantially rectangular in shape and may have interior and exterior surfaces or panels. In exemplary embodiments, the frame 12 may comprise an interconnected upper, lower, right side, and a left side piece, but may be substantially open on the front or rear sides thereof such that a side assembly 14 may be mounted to the frame 14 to substantially cover said front and rear openings. The frame 12 may be configured to receive a first and second side assembly 14 in a back to back arrangement. The side assemblies 14 may comprise digital displays, covers (i.e., access panels), poster holders (illuminated or unilluminated), some combination thereof, or the like. The poster holders may be configured to receive a static poster and may be back or edge illuminated. In exemplary embodiments, the covers and the poster holders may serve as access panels, though any of the foregoing may be moved or removed to allow access to the interior of the assembly 10. For example, without limitation, the assembly 10 may comprise two electronic displays placed back-to-back, or a single electronic display placed back-to-back with a poster holder. Regardless, the frame 12 may be configured to be connected to the stand 8, another object, or directly to the ground.

[0039] In embodiments comprising a single side assembly 14, the frame 12 may be a five-sided box. Namely, the frame 12 may comprise an interconnected upper, lower, right side, and a left side piece as well as a front or rear panel. However, the frame 12 may be substantially open on the rear or front sides thereof, respectively, such that the side assembly 14 may be mounted to substantially cover said opening.

[0040] As will be explained in greater detail herein, the assembly 10 may further comprise an electronics cavity 18 for storing electronic components 30 for operating the assembly 10. The electronics cavity 18 may be located in the space between the side assemblies 14 and the frame 12. Stated another way, the first and second side assemblies 14 may share a common electronics cavity 18.

[0041] Figures 1 and 2 illustrate the side assemblies 14 in a closed position such that the side assemblies 14 are in contact with the frame 12 or are located substantially parallel to the ground. As will be explained in greater detail herein, the side assemblies 14 may be hingedly mounted to the frame 12 by way of a hinging device 22. A first and

second hinging device 22 may be located on either side of the frame 12 so as to connect the first and second side assembly 14 to the frame 12 in a hinged fashion. The first and second hinging devices 22 may be the same or may be different. For example, without limitation, the hinging devices 22 used to hingedly mount a side assembly 14 comprising a digital display may be the same or may be different from the hinging device 22 used to mount a side assembly 14 comprising a poster holder. In exemplary embodiments, the hinging devices 22 may be located on an upper portion of the frame 12, such that the side assemblies 14 rotate outward along a substantially horizontal axis. In other exemplary embodiments, the hinging devices 22 may be located along an edge of the frame 12, such that the side assemblies 14 rotate outward along a substantially vertical axis. Any location of the hinging devices 22 is contemplated.

[0042] **Figure 3** is a front perspective view of the assembly 10 of figure 2 illustrated with one of the side assemblies 14 in an open position. The side assembly 14 may rotate via the hinging device 22 into the opened position such that the bottom of the side assembly 14 is swung outward and away from the frame 12. This may allow access to the electronics cavity 18 such that personnel may service the electronic components 30 located therein.

[0043] The assembly 10 may further comprise a pair of aid devices 20, preferably having a first end and a second end, though such is not required. In exemplary embodiments, the aid devices 20 may be gas springs, though any type of aid device is contemplated. Such aid devices 20 may include, but are not limited to, any device which utilizes a mechanical advantage in order to assist in moving the side assemblies 14 between an open position or closed positions as well as, or alternatively, to temporarily secure the side assemblies 14 in the open position or closed position. Other exemplary aid devices 20 include, but are not limited to, struts, springs, block and tackle, counterweights, levers, gears, tethers, belts, chains, motors, screws, some combination thereof, or the like.

[0044] The first end of the aid devices 20 may be mounted to either side of the side assembly 14 and the second end of the aid devices 20 may be mounted to either side of the interior of the frame 12. In exemplary embodiments, the first end of the aid devices 20 is mounted lower relative to second end of the aid devices 20, though the opposite is contemplated. The aid devices 20 may be configured to assist with movement of the side assemblies 14 between the open and the closed positions as well as temporarily securing the side assemblies 14 in the opened or the closed positions.

[0045] In exemplary embodiments, the side assemblies 14 may be lockable to the frame 12 or the housing 6 such that the side assemblies 14 cannot normally be moved from the closed position unless unlocked. This may assist in restricting access to the electronics cavity 18 to authorized personnel.

[0046] **Figure 4** is a front perspective view of the assembly 10 of figure 2 illustrated with one of the side assemblies 14 removed so as to illustrate the electronics cavity 18. A gasket 28 may extend around the perimeter of either or both sides of the frame 12. The gaskets 28 may provide a substantially air tight seal when the side assemblies 14 are placed in the closed position. The gaskets 28 may ensure or assist in allowing the electronics cavity 18 to maintain a substantially air tight seal, though such is not required.

[0047] A plate 19 may be located in the electronics cavity 18 and the electronic components 30 may be mounted thereto. Alternatively, or in addition, an electronics plate 42 may be located in the electronics cavity 18. In exemplary embodiments, the electronics plate 42 may be mounted to the frame 12 such that the electronics plate 42 extends substantially parallel to the front surface of the electronic side assemblies 14. Similarly, in exemplary embodiments the plate 19 may be mounted to, or form, the rear surface of one or more of the side assemblies 14. However, any location and orientation of the plate 19 and the electronics plate 42 is contemplated.

[0048] The electronic components 30 may comprise any number of components used to operate the assembly 10 and its various components. Such electronic components 30 may include, but are not limited to, power sources, power distribution components, video players, video receiver boards, processors, electronic storage devices, communications equipment, wireless transmitter/receivers, network connectivity devices, printed circuit boards, and the like. In exemplary embodiments, a number of the electronic components 30 may be utilized to operate both side assemblies 14. For example, but not to serve as a limitation, at least the video players, video receiver boards, communications equipment, wireless transmitter/receivers, and network connectivity devices may be shared. This may reduce the number of electronic components 30 required. In exemplary embodiments, the plate 19 or the electronics plate 42 may comprise a server rack, though such is not required.

[0049] Each hinging device 22 may comprise a frame hinge plate 26 and a first and second display hinge plate 24. The frame hinge plate 26 may be located on the exterior panels on either side of an upper portion of the frame 12 such that the frame hinge plate 26 extends substantially perpendicular relative to the electronics plate 42. The display

hinge plates 24 may be located on either side of an upper portion of each of the side assemblies 14 such that the display hinge plates 26 extend substantially perpendicular relative to the electronics plate 42. The display hinge plate 24 may comprise one or more notches or apertures corresponding to notches or apertures located on the frame hinge plate 26. Any number of fasteners 27 may extend through the corresponding notches or apertures in the display hinge plate 24 and the frame hinge plate 26 such that the frame hinge plate 26 may be hingedly secured to the display hinge plate 24. The fasteners 27 may include threaded fasteners, pins, bolts, screws, nails, or the like. This is merely exemplary, any type of hinge device 22 is contemplated. In exemplary embodiments, the frame hinge plates 26, the display hinge plates 24 and the fasteners 27 may be configured to serve as the main or sole mechanical attachment points for mounting the side assemblies 14 to the frame 12.

[0050] The hinge device 22 may provide for easy removal of one or both of the side assemblies 14 when servicing the assembly 10. The fasteners 27 may simply be removed from either side of the side assembly 14 and the entire side assembly 14 may be removed. Additionally, removal may require relatively minor additional steps such as, but not limited to, the disconnection of various electrical wires and other components as further described herein. A replacement side assembly 14 may then be installed. Installation may comprise, but is not limited to, moving the Additionally, installation of the new side assembly 14 may require relatively minor additional steps such as, but not limited to, the connection of the aforementioned various electrical wires and other components as further described herein. The side assembly 14 being serviced may then be returned to a service center for servicing. This may minimize downtime of the assembly 10.

[0051] Additionally, the assembly 10 may require connection to an external power source, communications network, and the like to operate. This may require connecting into utility lines. In exemplary embodiments, connection to said utility lines may be made through separate connectors 72 located on the frame 12, within the cavity 18, on the plate 19, on the electronics plate 42, or at another location. These connectors 72 may be connected to the other various electronic components 30 via electrical wiring, ethernet cable, telephone cable, coaxial cable, fiber optic cable, or the like. The disconnection and reconnection of such wiring from the connectors 72 may be required when removing or installing a side assembly 14. In this way, the connection into the utility lines may not be disturbed when servicing the assembly 10. In exemplary embodiments, the connectors 72 may also act as pass through devices 35.

[0052] **Figure 5** illustrates exemplary flow paths through the assembly 10 of figure 4. **Figure 6** illustrates a top sectional view of an exemplary side assembly 14 to further illustrate said exemplary flow paths. Each side assembly 14 may comprise a cover panel 17 that faces an intended viewer. An electronic display 11 may be located behind, spaced apart from, and substantially parallel to the cover panel 17. Cover panel 17 may be comprised of any substantially transparent or translucent material and may be comprised of multiple layers. The cover panel 17 may be comprised of a toughened material or may comprise optical adhesive placed between the multiple layers such that the cover panel 17 is strengthened against vandalism. The electronic display 11 may be any type of electronic display 11, including but not limited to, a liquid crystal display (LCD), light emitting diode (LED) display, organic LED (OLED) display, plasma display, or the like. The space between the rear surface of the cover panel 17 and the front surface of the electronic display 11 may define a first channel 25. A side assembly housing 15 may surround the electronic display 11 such that the combination of the cover panel 17 and the side assembly housing 15 substantially encloses the electronic display 11. One or more of the side assemblies 14 may further configured to receive touch input. For example, without limitation, the electronic display 11 may comprise a capacitive or resistive touch screen and related components required to operate said touch screen, though any type of touch screen is contemplated.

[0053] A backlight 21 may be located behind and substantially parallel to the electronic display 11. The backlight 21 may be spaced apart from the electronic display 11, though such is not required. A second channel 23 may be located within the side assembly 14 and may be configured to receive ambient air 38. The second channel 23 may permit ambient air 38 to flow substantially vertically through the side assembly 14 from top to bottom, or from the bottom to the top. In exemplary embodiments, the second channel 23 is defined, at least in part, by the space between the rear surface of the backlight 21 and the rear surface of the side assembly housing 15, though any location is contemplated.

[0054] A first and a second side channel 32 may extend along either side of the side assembly 14. The side channels 32 may be configured to receive circulating gas 36. In exemplary embodiments, the side channels 32 are defined, at least in part, by the space between the second channel 23 and the side of the side assembly housing 15, though any location is contemplated.

[0055] One or both sides of the frame 12 may comprise a side gap 13 located between interior and exterior side panels. As such, the assembly 10 may comprise a first and a second side gap 13, where each is located on either side of the frame 12. In other exemplary embodiments, the assembly 10 may comprise only a first side gap 13. Apertures may be located along the interior panels of the side(s) of the frame 12 having the side gap(s) 13 such that circulating gas 36 may be passed from the electronics cavity 12 into and out of the side gap(s) 13. In exemplary embodiments, the circulating gas 36 may flow from the first side gap 13, through the first side channel 32, through the first channel 25, through the second side channel 32, through the second side gap 13, through the electronics cavity 18, and be returned to the first side gap 13, thereby forming a closed loop. In exemplary embodiments where the assembly 10 comprises only the first side gap 13, the circulating gas 36 may pass directly from the electronics cavity 18 into or out of the first or the second side channel 32. Additionally, the circulating gas 36 may be split and travel through first channel 25 located in each respective side assembly 14. Stated another way, the closed loop may pass through each side assembly 14 and return to the cavity 18. It is notable that the side gaps 13 are optional.

[0056] One or more fans 34 may be mounted to said apertures in the interior panels of the side of the frame 12 to force the circulating gas 36 through the closed loop, though it is contemplated that any number of fans 34 may be placed at any number of locations along the path of the circulating gas 36.

[0057] The bottom and top of the frame 12 may similarly comprise interior and exterior panels with an upper gap 41 and a lower gap 40 located therebetween, though such is not required. Apertures may be located along the exterior panels of the bottom and top of the frame 12 such that ambient air 38 may be ingested from outside of the assembly 10 and exhausted from inside of the assembly 10. These apertures may form the exhaust 9 and the intake 16. In exemplary embodiments, ambient air 38 may be ingested from the bottom of the assembly 10 into the lower gap 40. The ambient air 38 may then travel vertically upwards through the second channel 23 in the side assembly 14 and into the upper gap 41. The ambient air 38 may then be exhausted through the intake 16, thus forming an open loop. In the exemplary embodiments, the ambient air 38 may be split and travel through each of the second channels 23 located in each of the respective side assemblies 14.

[0058] One or more fans 34 may be mounted to said apertures in the exterior panels of the bottom of the frame 12 to force the ambient air 38 through the open loop,

though it is contemplated that any number of fans 34 may be located in any number of locations along the path of the ambient air 38.

[0059] In exemplary embodiments where the side assembly 14 is an electronic display, the ambient air 38 flowing through the second channel 23 may be in thermal communication with the backlight 21 so as to absorb heat generated therefrom, though such is not required. In exemplary embodiments where the side assembly 14 is an illuminated poster holder, the ambient air 38 flowing through the second channel 23 may be in thermal communication with the illumination devices so as to absorb heat generated therefrom, though such is not required. In still other exemplary embodiments where the side assembly 14 is a cover, the ambient air 38 may optionally flow through a second channel 23 located in the cover, though such is not required. Regardless, the ambient air 38 flowing through the second channel 23 may be in thermal communication with circulating gas 36 flowing through the closed loop such that the relatively cool ambient air 38 may remove heat from the relatively warm circulating gas 36. The ambient air 38 flowing through the open loop may be in thermal communication with the circulating gas 32 flowing through the closed loop so as to absorb heat therefrom while not allowing the ambient air 38 and the circulating gas 32 to substantially mix. For example, without limitation, the ambient air 28 traveling through the second channel 23 may be in thermal communication with the circulating gas 38 flowing through the cavity 18.

[0060] It is notable that the use of airflow channels, such as but not limited to, the first channel 25, the second channel 23, and the side channels 32 may not be required in embodiments where the side assembly 14 is a poster holder or cover. In such embodiments, the airflow may be directed into the remaining side assembly 14 comprising such airflow channels. If no such side assembly 14 is utilized, the airflow may simply circulate within the cavity 18. In some exemplary embodiments, the poster holder or cover may still utilize some or all of aforementioned the airflow channels. Regardless, the number of fans utilized may be reduced or increased to accommodate the number of airflow channels used.

[0061] **Figure 7** is a front perspective view similar to figure 1 of another exemplary embodiment of the assembly 10 also indicating section lines A-A and B-B.

[0062] **Figure 8** is a front perspective view of the assembly 10 of figure 7 illustrated with both side assemblies 14 in the open position. The plate 19 may be mounted to one of the side assemblies 14. In other exemplary embodiments, the plate 19 may form a part

of the side assembly 14. Many or all of the electronic components 30 may still be shared by the side assemblies 14.

[0063] The shared electronic components 30 may be located on the plate, though such is not required. In exemplary embodiments, the side assemblies 14 of the same type (e.g., electronic displays, poster holders, or covers), including the electronic components 30 located on or in the side assemblies 14, are substantially identical for the front or rear facing side assembly 14 of the same type (e.g., when both side assemblies 14 comprise electronic displays or both side assemblies 14 comprise poster holders) such that the two may be interchanged. In this way, a single type of side assembly 14 to be used to replace any of that type side assembly 14 or may be freely substituted with a different type side assembly 14. For example, without limitation, a separate front and back side assembly 14 need not be stored as spares for a single assembly 10. Instead, a single spare side assembly 14 may be used to replace either the front or back side assembly 14. This may reduce the need to store additional spare side assemblies 14. Stated another way, a side assembly 14 comprising an electronic display may be placed on either the front or the rear of the assembly. Likewise, a side assembly 14 comprising an electronic display may be freely substituted with a side assembly 14 comprising a cover.

[0064] **Figure 9** is a front perspective exploded view of the assembly of figure 8. An electronics plate 42 may be mounted to the frame 12, though such is not required. The electronics plate 42 may be located in an upper portion of the electronics cavity 18, though any location is contemplated. The electronics plate 42 may be mounted so as to extend substantially parallel with the front surface of the side assemblies 14 when the side assemblies 14 are in the closed position. The electronics plate 42 may be configured to receive the electronic components 30 and additional electronic components 44, which may be mounted thereto. In exemplary embodiments, the additional electronic components 44 may comprise customer-specific or customer-installed electronic components or other components for operating the assembly 10. However, any type of electronic components 44 and 30 are contemplated, such as but not limited to, computers, processors, routers, servers, machine to machine communications equipment, wireless connectivity devices, Bluetooth connectivity devices, near field communication devices, cameras, electronic storage devices, memory, and the like. In exemplary embodiments, the electronics plate 42 may comprise a server rack, such as but not limited to, a 1U server rack.

[0065] By placing the side assemblies 14 in the opened position, the electronics cavity 18, the plate 19, the electronics plate 42, the related electronic components 30 and additional electronic components 44 may be serviced. Additionally, the side assemblies 14 themselves may be serviced by removing the display assemblies from the hinging device 22 as previously discussed.

[0066] Various pass through devices 35 may be located in the frame 12 or other walls defining the cavity 18 such that power lines, communication lines, and the like may be passed into the cavity 18 from outside. These pass through devices 35 may be configured to provide a substantially air and water tight seal, though such is not required. In other embodiments, the pass through devices 35 may provide a level of ingress and egress protection. Any number and location of said pass through devices 35 are contemplated. This may help to reduce the number of entry and exit points in the assembly 10 and simplify the cabling. The pass through devices 35 may provide a connection/disconnection point for wiring and cabling. The cavity 18 may provide a substantially sealed, cooled, connected, and/or powered electronics cavity 18 for mounting electronic components, such as but not limited to, the additional electronic components 44 and the electronic components 30.

[0067] Figure 9 illustrates an exemplary assembly 10 where the fans 34 for the ambient air 38 may be located on the top of the frame 12 in the apertures of the upper gap 41.

[0068] **Figure 10** is a top sectional view taken along section line A-A of figure 7 and illustrating exemplary side assemblies 14 in the closed position, where the side assemblies 14 comprise electronic displays. The second channel 23 may comprise a corrugation layer 46 located between the backlight 21 and the electronics cavity 18. The ambient air 38 may pass through the corrugation layer 46. As illustrated in figure 10, the assembly 10 may only comprise the first side gap 13. It is contemplated that the first side gap 13 may be located on either side of the assembly 10 or may not be required at all. It is further contemplated that a corrugation layer 46 may be utilized in side assemblies 14 comprising a poster holder or cover.

[0069] **Figure 11** is a side sectional view taken along section line B-B of figure 7. As illustrated in figure 11, the lower gap 40 is optional. Instead, ambient air 38 may enter via the intake 41 and be ingested directly into the side assemblies 14 where it may travel through the second channel 23 to the upper gap 41 and exit via the exhaust 9. Alternatively, the air may enter via the exhaust 9 and exit via the intake 41.

[0070] **Figure 12A** and **figure 12B** is a rear perspective view of another exemplary assembly 10. Figures 12A-12B illustrates how the side assemblies 14 may be rotated outward along a substantially horizontal axis or a substantially vertical axis. The side assemblies 14 may act as an access panel. In exemplary embodiments where the side assemblies 14 are covers, the side assembly 14 may be comprised of sheet metal or black glass, though any type of material is contemplated. In exemplary embodiments comprising black glass, the black glass may be comprised of one or more transparent or translucent panels wherein one or more of the panels are printed with black ink. In exemplary embodiments, the panels may alternatively or additionally be printed with a logo or other information. The panels may be comprised of a toughened material or may comprise optical adhesive placed between two panels such that the cover is strengthened against vandalism.

[0071] In other exemplary embodiments, where the side assembly 14 comprises a poster holder configured to hold a static poster, the side assembly 14 may comprise a transparent cover located above a plate to define a poster cavity, which may be configured hold the poster therebetween. Illumination devices may be placed within, around, or along the poster cavity to provide backlighting or edge lighting to illuminate the poster.

[0072] In exemplary embodiments, the side assemblies 14 may swing open horizontally (as shown in figure 12A) or vertically (as shown in figure 12B). In exemplary embodiments where the side assembly 14 swings open vertically, aid devices 20 may likewise be used to assist in moving the side assembly 14 between the open and closed positions as well as securing the side assembly 14 in the open and closed positions.

[0073] Although the flow of the ambient air 38 and the circulating gas 36 may be shown and described herein with respect to particular directions and orientations, it is contemplated that the ambient air 38 and the circulating gas 36 may flow in other directions. For example, without limitation, ambient air 38 and circulating gas 36 shown as flowing clockwise may flow counter-clockwise, when shown flowing vertically from top to bottom may flow from bottom to top, when shown flowing horizontally from right to left may flow from left to right, when shown flowing vertically may flow horizontally, when shown flowing horizontally may flow vertically, and the like.

[0074] It is contemplated that the assembly 10, or various components thereof, may be adapted for and/or used with any size side assemblies 14 in any application. For example, but not to serve as a limitation, the assembly 10, or various components thereof, may be adapted for and/or used with a vehicle topper unit such as is illustrated and

described in U.S. Patent Application Serial No.: 15/450,365 filed March 6, 2017, the disclosures of which are hereby incorporated by reference in their entirety.

[0075] **Figure 13** is a front perspective view of another exemplary assembly 100 also indicating Detail A. Figure 13 through figure 18B illustrate and describe an adaptation of the assembly 10 for use with a vehicle topper unit as previously mentioned. Similar features have been similarly numbered but increased by 100 (e.g., assembly 10 and assembly 100). The assembly 100 may comprise a frame 112 which may be rectangular in shape, though any shape is contemplated. The frame 112 may be covered by cladding that forms a housing. The cladding may provide an aesthetically pleasing appearance and may improve aerodynamics. The frame 112 may be adapted to be mounted to the roof of a vehicle, though such is not required. A first and second side assembly 114 may be attached to the frame 112, though any number of side assemblies 114 are contemplated. In exemplary embodiments, the first and second side assemblies 114 are placed back-to-back on either side of the frame 112. The assembly 100 may further comprise a pair of mounting devices 150. In exemplary embodiments, the mounting devices 150 may be located on the underside of the frame 112 and may be feet configured to permit the assembly 100 to be mounted to the roof of a vehicle, though any type of mounting device 150 is contemplated.

[0076] A fan 134 may be located on an aperture in the frame 112 and may be configured to permit the ingestion of ambient air 138. Once ingested, the ambient air 138 may travel horizontally through channels in the side assemblies 114 and exit through apertures on the other end of the frame 112. This may form an open loop. It is contemplated that the fan 134 may be located at any location along the path of the ambient air 138.

[0077] **Figure 14** is a front perspective view of the assembly 100 of figure 13 illustrated with one of the side assemblies 114 in the open position. The side assemblies 114 may be hingedly mounted to the frame 112 by way of a hinging device 122. The hinging device 122 may permit the side assemblies 114 to be moved between a closed position, wherein the respective side assembly 114 rests against or is located in close proximity with the frame 112 and/or where the front surface of the respective side assembly 114 is substantially perpendicular to the ground, and an open position wherein the respective side assembly 114 is rotated outwardly from the frame 112 and/or at least one edge of the side assembly 114 is moved away from the frame 112. A gasket 128 may extend around the perimeter of the surfaces of the frame 112 which contact the side

assemblies 114. The gaskets 128 may be configured to provide a substantially air tight seal in the electronics cavity 118 when the side assemblies 114 are located in the closed position.

[0078] An electronics cavity 118 may be located between the rear surfaces of the side assemblies 114. The electronics cavity 118 may comprise a plate 142 that is configured to receive a number of electronic components 130 or additional electronic components 144 which may be mounted thereto. In exemplary embodiments, the plate 142 may be mounted to the frame 112. In other exemplary embodiments, the plate 142 may be mounted to, or form a part of, one of the side assemblies 114. Various pass through devices 135 may be located in the walls defining the cavity 118 such that power lines, communication lines, and the like may be passed into the cavity 118 from outside. The pass through devices 135 may be configured to provide a substantially air and water tight seal or otherwise provide ingress and egress protection. This may help to reduce the number of pass through points in the assembly 100 and simplify the cabling. Additionally, the pass through devices 135 may provide a single or limited number of connection or disconnection points for removing the wiring for servicing the side assemblies 114. In exemplary embodiments, the electronics cavity 118 may provide a cooled, powered, connected, and/or sealed area for electronic components, such as but not limited to, the electronic components 130 and the additional electronic components 144.

[0079] When either or both the of side assemblies 114 are placed in the open position, the electronics cavity 118 may be exposed. This may allow access to the electronics cavity 118, the plate 142, and the electronic components 130 such that personnel may service the electronic components 130 located therein. In exemplary embodiments, the side assemblies 114 may be selectively locked to the frame 112 such that the respective side assembly 114 cannot normally be moved from the closed position unless unlocked. This may assist in restricting access to the electronics cavity 118 to authorized personnel.

[0080] The frame 112 may comprise interior and exterior surfaces. In exemplary embodiments, a lower gap 140 may be located in the space between the interior and exterior surfaces of the frame 112 along a lower portion thereof. Stated another way, the lower gap 140 may be located between the bottom of the electronics cavity 118 and the bottom of the frame 112.

[0081] **Figure 15** is a rear perspective view of the assembly 100 of figure 13 is illustrated with both of the side assemblies 114 in the open position and also indicating Detail B. A first and second strut 152 may extend between the frame 112 and each of the respective side assemblies 114. In other exemplary embodiments, a pair of struts 152 may be used for each respective side assembly 114. The strut 152 may be configured to temporarily secure the respective side assembly 114 in the opened position, although it is contemplated that the strut 152 may be configured to also temporarily secure the respective side assembly 114 in the closed position. Alternatively, any of the aid devices 20 may be utilized in conjunction with or in substitution of the struts 152.

[0082] In exemplary embodiments, the struts 152 may be mounted to each of the respective side assemblies 114 in a rotatable fashion. The struts 152 may be mounted in a rotatable fashion by way of a pin, bearing, hinge, fastener, or the like, though any device or mounting configuration is contemplated. Regardless, the struts 152 may be configured to be temporarily secured to each of the respective side assemblies 114 such that the respective side assembly 114 is propped or otherwise held in the open position. While the struts 152 are discussed as being mounted to each of the respective side assemblies 114 and temporarily secured to the frame 112, it is contemplated that the struts 152 may instead be mounted to frame 112 and temporarily secured to each of the respective side assemblies 114.

[0083] **Figure 16** is a front perspective view of the assembly 100 of figure 14 illustrated with one of the side assemblies 114 removed. Circulating gas 136 may travel vertically through the electronics cavity 118 where it is separated and passes through each respective side assembly 114. In exemplary embodiments, the circulating gas 136 flows through a channel between a cover glass and an electronic display in each of the respective side assemblies 114. The circulating gas 136 may then travel through the lower gap 140 and be returned to the electronics cavity 118 via apertures in the interior surfaces of the frame 112, thereby forming a closed loop. In exemplary embodiments, these apertures in the frame 112 may have fans 134 mounted thereto to move the circulating gas 136 through the closed loop, though it is contemplated that the fans 134 may be located anywhere along the path of the circulating gas 136.

[0084] U.S. Patent Application Serial No.: 15/450,365 filed March 6, 2017, the disclosures of which are hereby incorporated by reference in their entirety, describes an exemplary thermal management system for the assembly 100 including, but not limited to, open and closed loop pathways for ambient air and circulating gas.

[0085] It is contemplated that either or both of the side assemblies 114 may comprise an electronics display, a poster holder, or a cover. It is further contemplated that some or all of the electronic components 130 used to operate the side assemblies 114 may be located on the plate 142. It is also contemplated that the side assemblies 114 of the same type (e.g., comprising an electronic display, poster holder, or cover) may be substantially identical, such that the side assemblies 114 located on the left or right side of the assembly 100 may be freely substituted.

[0086] **Figure 17** is a detailed top perspective view of Detail A of figure 13. The hinging device 122 may comprise a first and second display hinge plate 156, a first frame hinge plate 154, and a second frame hinge plate 158. Each of the first and second display hinge plates 156 may be substantially "L" shaped and may be configured to extend between a rear surface of the respective side assemblies 114 and the first frame hinge plate 154. The first frame hinge plate 154 may be mounted to either end of the frame 112. Optionally, a second frame hinge plate 158 may be located on the other side of the first and second display hinge plates 156 such that the first and second display hinge plates 156 are sandwiched between the first frame hinge plate 154 and the second frame hinge plate 158. It is contemplated that the second display hinge plate 156 may not be required, but may be used to provide added strength and stability. Additionally, the second hinge plate 158 may be configured to extend behind a portion of the side assemblies 114 so as to serve as a backstop.

[0087] A first fastener 127 may extend through the first frame hinge plate 154, the first display hinge plate 156, and the second frame hinge plate 158. Likewise, a second fastener 127 may extend through the first frame hinge plate 154, the second display hinge plate 156, and the second frame hinge plate 158. The fastener 127 may be a pin or another device permitting rotational movement of the first and second display hinge plates 156. In exemplary embodiments, the second frame hinge plate 158 may be selectively secured to the respective side assembly 114 such that the respective side assembly 114 may be temporarily secured in the closed position. The frame hinge plate 156, the display hinge plate 154, and the fasteners 127 may be configured to bear all or substantially all of the weight of the respective side assembly 114.

[0088] The design of the hinge device 122 may provide for easy removal of one or both of the side assemblies 114 when servicing the assembly 100. The fasteners 127 may be removed from either side of the respectively side assembly 114 and the entire side assembly 114 may be removed. Additionally, the disconnection of wiring, along with

other steps, may be required. A replacement side assembly 114 may then be installed. Additionally, the connection of wiring, along with other steps, may be required. The side assembly 114 being serviced may then be returned to a service center for servicing. This may minimize downtime of the assembly 100.

[0089] **Figure 18A** is a detailed perspective view of Detail B of figure 15 also illustrating the otherwise hidden strut 152. **Figure 18B** is a top perspective view of the assembly 100 of figure 18A illustrated with the side assembly 114 in the open position. As can be seen, the strut 152 may be moved between a supporting and a stored position. The strut 152 may be rotated into the stored position such that the strut 152 is substantially aligned with the side assembly 114 when the side assembly 114 is in the closed position. In this way, the strut 152 is no longer bearing the weight of the side assembly 114 and may be stored within the respective side assembly 114 when the strut 152 is not being used to keep the side assembly 114 in the open position. The strut 152 may be rotated into the supporting position where the strut 152 is secured at an angle to the frame 112 such that the side assembly 114 may be propped or otherwise held in the open position. In exemplary embodiments, the strut 152 may comprise a notch 153 configured to be temporarily secured to a corresponding bracket or groove located on the frame 112 such that the strut 152 bears some or all of the weight of the side assembly 114 so as to prop or hold the respective side assembly 114 in the open position.

[0090] **Figure 19A** through **figure 20** illustrates another exemplary embodiment of the assembly 210. Similar features have been similarly numbered but increased by 100 (e.g., assembly 10 and 110 now assembly 210). The assembly 210 may comprise a second open loop channel 262 for ambient air. The second open loop channel 262 may be located in one or more of the side assemblies 214. In exemplary embodiments, the second open loop channel 262 is located in the side assembly or assemblies 214 comprising a cover or a poster holder, though it is contemplated that the second open loop channel 262 may be located in any side assembly 214, including those comprising digital displays. The second open loop channel 262 may be located behind an open loop channel cover 264. An open loop channel plate 266 may be located behind said open loop channel cover 264. In exemplary embodiments, the open loop channel plate 266 is spaced apart from, and located substantially parallel to, the open loop channel cover 264. The open loop channel cover 264 may have substantially the same surface area as the open loop channel plate 266, though such is not required. In exemplary embodiments, the open loop channel cover 264 may be the outermost surface of the respective side of

the assembly 210 and/or of the respective side assembly 214 such as is illustrated in figure 19B. However, in other exemplary embodiments, an outer cover 268 may be located above the open loop channel cover 264, such as is illustrated in figure 19A. In such embodiments, the outer cover 268 may be positioned substantially parallel with, spaced apart from, and cover the entirety of the open loop channel cover 264, though such is not required.

[0091] Regardless, the second open loop channel 262 may be defined by the space between the open loop channel cover 264 and the open loop channel plate 266. The second open loop channel 262 may further comprise one or more side panels 270 configured to extend between the open loop channel cover 264 and the open loop channel plate 266 to further define the second open loop channel 262.

[0092] Any number of electronic components or equipment 244 or 230 may be located in or near the second open loop channel 262, such as but not limited to, being mounted to the open loop channel cover 264 or the open loop channel plate 266. Such electronic components or equipment 244 or 230 may include a power supply or module, though any electronic component or equipment is contemplated. The second open loop channel 262 may be configured to transfer heat from the side assemblies 214, the electronic components or equipment 244 or 230, other components of the assembly 210 to the ambient air passing through the second open loop channel 262. The second open loop channel 262 may comprise surface features, materials, or components configured to facilitate the transfer of heat, though such is not required. These may include, without limitation, fins, thermally conductive materials, heat exchangers, or the like. In exemplary embodiments, the open loop channel 262 may comprise a corrugated layer 246. It is contemplated that any number of fans 234 may be placed at any location near or along the second open loop channel 262 to force or encourage the flow of ambient air through the second open loop channel 262.

[0093] In exemplary embodiments, the ambient air 238 may enter the assembly 210 at or near the top of the assembly 210 or the respective side assembly 214. Similarly, in exemplary embodiments, the ambient air 238 may be exhausted at or near the bottom of the assembly 210 or the respective side assembly 214 such that the ambient air 238 flows vertically downwards through the second open loop channel 262. In other exemplary embodiments, the ambient air 238 may enter the assembly 210 or the respective side assembly 214 at or near the bottom of the assembly 210 or the respective side assembly 214 and ambient air 238 may exhaust the assembly 210 at or near the top

of the assembly 210 or the respective side assembly 214 such that ambient air flows vertically upwards through the second open loop channel 262. The second open loop channel 262 may share the intake 241 and the exhaust 209 such that ambient air enters via the common intake 241 and is separated into flow paths which travel into the two side assemblies 214. In other exemplary embodiments, the second open loop channel 262 may have a separate intake and exhaust.

[0094] The oppositely facing side assembly 214 may comprise an electronic display 211 located in front of a backlight 221. Circulating gas 236 may pass through the first channel 225 defined by the space between the electronic display 211 and a cover panel 217. The circulating gas 236 may pass into a cavity 218 located between the side assemblies 214. The cavity 218 may contain one or more fans 234 for moving the circulating gas through the closed loop pathway. The cavity 218 may also comprise electronic components 230 or 244 and an electronics plate 242 for mounting the same. The cavity 218 may comprise one or more heat transfer devices 282, though such is not required. In such embodiments, ambient air 238 may also be passed through the heat transfer device 282, though such is not required.

[0095] The side assembly 214 embodiment illustrated and described in figure 19A through figure 20 may be the same as, or contain the features illustrated or described with respect to, other side assemblies 14 and 114 embodiments illustrated or described herein, though such is not required. Any of the illustrated or described embodiments, or features thereof, may be utilized with any of the other embodiments illustrated or described herein.

[0096] In exemplary embodiments, the assembly 210 may be mounted in an elevated position at a downward angle. In exemplary embodiments, the assembly 210 may be mounted to a sign, pole, street lamp, street fixture, sidewalk fixture, building, structure, ground, or the like, though mounting to any surface is contemplated. The assembly 210 may be positioned at a downward angle, such that the side assembly 214 facing the ground may be viewed by those traveling underneath. The downward angle may be substantially 50 degrees, though any angle is contemplated.

[0097] In such embodiments, the second open loop channel 262 may be placed on the side assembly 214 which would normally receive the greatest solar load. For example, without limitation, the second open loop channel 262 may be placed on the side assembly 214 which would normally face upwards when mounted, though it is contemplated that the second open loop channel 262 may be located in either or both of the side assemblies 214. Such an embodiment may be used in conjunction with, but is not limited to, the

exemplary assemblies 210 mounted in an elevated position at a downward angle, because the solar loading may primarily be experienced on the upward facing side assembly 214. In this way, the second open loop channel 262 may be configured to remove some or all of the solar loading experienced on the upward facing side assembly 214. In such embodiments, the upward facing side assembly 214 may comprise the second open loop channel 262 and a cover and the downward facing side assembly 214 may comprise an electronic display or static backlit poster, though any combination of side assemblies 214 is contemplated.

[0098] Any embodiment of the present invention may include any of the optional or preferred features of the other embodiments of the present invention. The exemplary embodiments herein disclosed are not intended to be exhaustive or to unnecessarily limit the scope of the invention. The exemplary embodiments were chosen and described in order to explain the principles of the present invention so that others skilled in the art may practice the invention. Having shown and described exemplary embodiments of the present invention, those skilled in the art will realize that many variations and modifications may be made to the described invention. Many of those variations and modifications will provide the same result and fall within the spirit of the claimed invention. It is the intention, therefore, to limit the invention only as indicated by the scope of the claims.

CLAIMS

1. A field serviceable assembly comprising:
 - a frame;
 - a first and second side assembly, each having a rear surface and being moveably mounted to the frame in a back to back arrangement, wherein at least one of the side assemblies comprises:
 - a cover panel;
 - an electronic display located behind the cover panel;
 - a backlight located behind the electronic display;
 - a first channel configured to receive circulating gas; and
 - a second channel configured to receive ambient air;
 - a cavity located between the rear surfaces of the first and second side assemblies and the frame;
 - an electronics plate positioned within the cavity and configured to receive a plurality of electronic components, wherein said electronics plate is configured to remain stationary when said first and second side assemblies are moved between said opened position and said closed position, wherein movement into said opened position exposes said electronics plate to facilitate access to said electronic components located thereon;
 - a closed loop pathway comprising said cavity and said first channel;
 - a first open loop pathway comprising said second channel of said first side assembly; and
 - a second open loop pathway comprising said second channel of said second side assembly.
2. The field serviceable assembly of claim 1 further comprising:
 - a first and second frame hinge plate located on the frame; and
 - a first and second display hinge plate located on each of the first and second side assemblies;wherein the first and second frame hinge plates are configured to interact with the first and second display hinge plates so as to permit the first and second side assemblies to rotate outward.
3. The field serviceable assembly of claim 2 further comprising:
 - a plurality of fasteners; and

a plurality of apertures or notches located in the first and second frame hinge plates and the first and second display hinge plates, wherein the apertures or notches are located such that a single fastener is extendable through the first or second frame hinge plate and into the first or second display hinge plate for mounting the respective side assembly to the frame.

4. The field serviceable assembly of claim 3 wherein:
the plurality of fasteners comprise pins; and
the pins are configured to bear substantially an entire weight of the side assembly for which the pins are used.
5. The field serviceable assembly of claim 1 wherein:
the first channel is located between the cover panel and the electronic display.
6. The field serviceable assembly of claim 5 wherein:
the second channel is located behind the backlight.
7. The field serviceable assembly of claim 1 wherein:
the frame is configured for mounting to the ground.
8. The field serviceable assembly of claim 1 wherein:
the frame is configured for mounting to the roof of vehicle.
9. The field serviceable assembly of claim 1 further comprising:
a connector configured to be placed in electrical connection with an external power source and a communications network.
10. The field serviceable assembly of claim 1 wherein:
the first and second side assemblies are configured for rotation between an open position and a closed position by way of a first and second aid device, wherein said first and second aid devices are each configured to assist in moving the first and second side assemblies, respectively, between the open and the closed positions; and
the cavity is configured to remain substantially air tight while the first and second side assemblies are located in the closed position.
11. The field serviceable assembly of claim 1 wherein:
said electronics plate comprises a server rack.
12. The field serviceable assembly of claim 1 further comprising:

one or more pass through devices located on the frame and configured for passing cabling into the cavity.

13. A field serviceable assembly comprising:

a frame comprising a top panel, a right side panel, a left side panel, and a bottom panel, said panels being interconnected to form a substantially rectangular shape;

a first side assembly movably mounted to the frame and comprising:

a transparent layer;

an electronic display positioned behind said transparent layer;

a first channel configured to receive circulating gas and located between said transparent layer and said electronic display;

a second channel configured to receive a first flow of ambient air, wherein said second channel is positioned behind said electronic display;

a second side assembly moveably mounted to the frame and positioned in a back to back arrangement with said first side assembly, said second side assembly comprising:

a cover;

a plate spaced apart from, and positioned substantially parallel to, said cover; and

a third channel located between said cover and said plate, wherein said third channel is configured to receive a second flow of ambient air;

a number of hinges, each of which are connected to the frame and one or both of the first and second side assemblies and are configured to facilitate movement of said first and second side assemblies between an opened position and a closed position;

a cavity located between the first and second side assemblies and the frame, wherein said cavity is configured to receive circulating gas from said first channel; and

an electronics plate positioned within the cavity between, spaced apart from, and substantially parallel to rear surfaces of the first and second side assemblies, wherein said electronics plate is configured to remain stationary when said first and second side assemblies are moved between said opened position and said closed position, wherein said electronics plate is configured to receive a plurality of electronic components, and wherein movement into the opened position facilitates access to the electronic components installed at said fixed plate.

14. The field serviceable assembly of claim 13 wherein:

said electronics plate comprises a 1U server rack.

15. The field serviceable assembly of claim 13 wherein:

the first and second frame hinge plates are located on opposing sides of said frame; and

the first and second display hinge plates are located along an upper edge of said side assemblies such that said side assemblies are configured to rotate about a substantially horizontal axis.

16. The field serviceable assembly of any of claims 16-18 wherein:

the first and second frame hinge plates are located on the same side of said frame; and

the first and second display hinge plates are located along the same side of said side assemblies such that said side assemblies are configured to rotate about a substantially vertical axis.

17. A field serviceable assembly comprising:

a frame having a substantially rectangular shape and comprising a first and second frame hinge plate located on opposing sides of said frame;

a first and second side assembly rotatably mounted to the frame in a back to back arrangement such that each of the first and second side assemblies may be rotated outwardly along a substantially horizontal axis, wherein each of said first and second side assemblies comprises:

a transparent layer;

an electronic display located behind the transparent layer;

a backlight located behind the electronic display;

a corrugation layer located between the backlight and a rear surface of the side assembly, wherein the corrugation layer is configured to receive ambient air; and

a channel located between the transparent layer and the electronic display, wherein the first channel is configured to receive circulating gas;

a shared cavity defined by the space between the rear surfaces of the first and second side assemblies and the frame, wherein said shared cavity is in gaseous communication with each of the front channels; and

a server rack positioned within the cavity and configured to interchangeably receive any of a plurality of electronic components, wherein said server rack is configured to remain stationary when said first and second side assemblies are rotated between an opened position and a closed position, wherein movement into said opened position exposes said server rack to facilitate access to said electronic components located thereon.

Manufacturing Resources International, Inc.
Patent Attorneys for the Applicant/Nominated Person
SPRUSON & FERGUSON

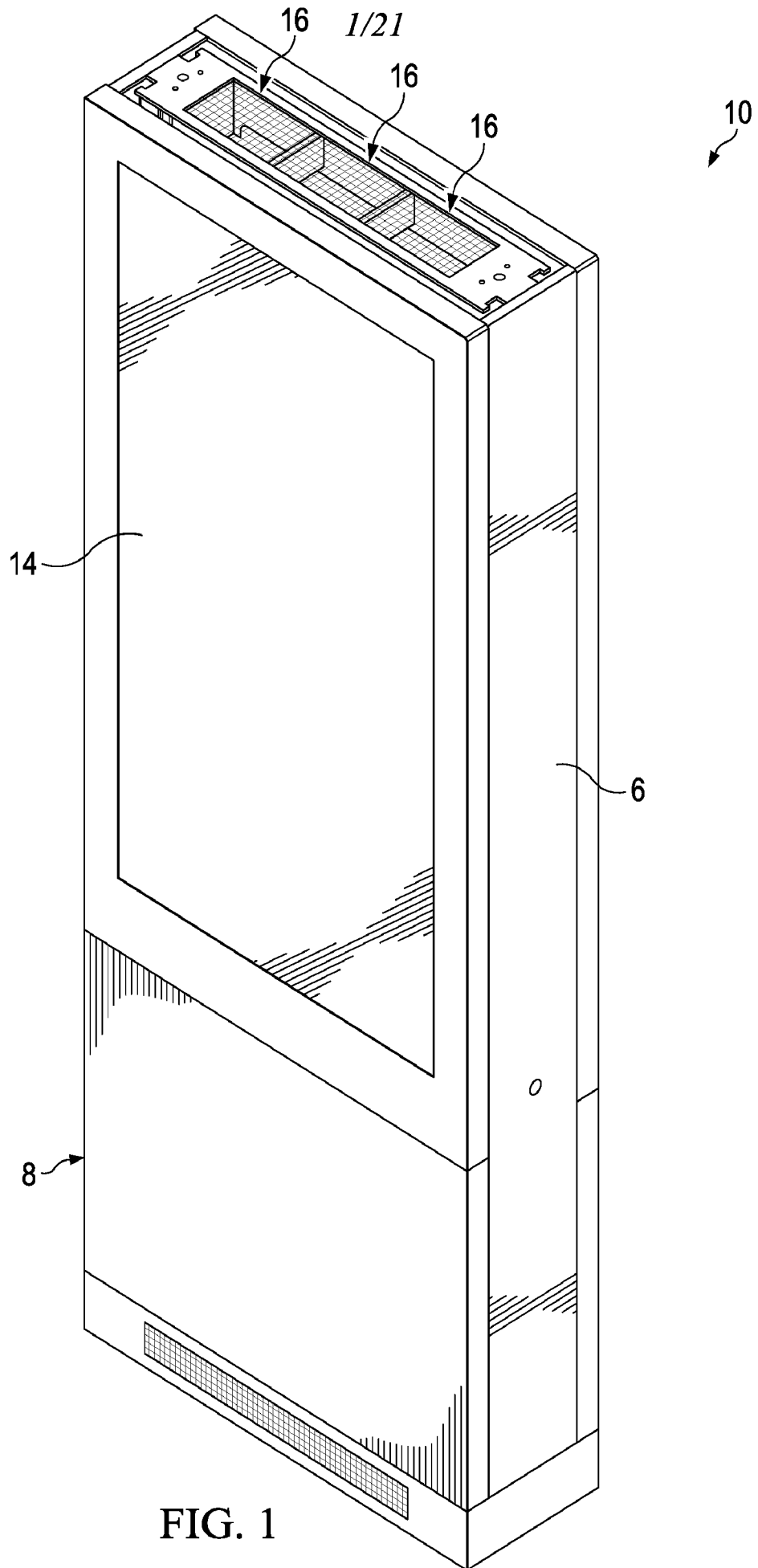

FIG. 1

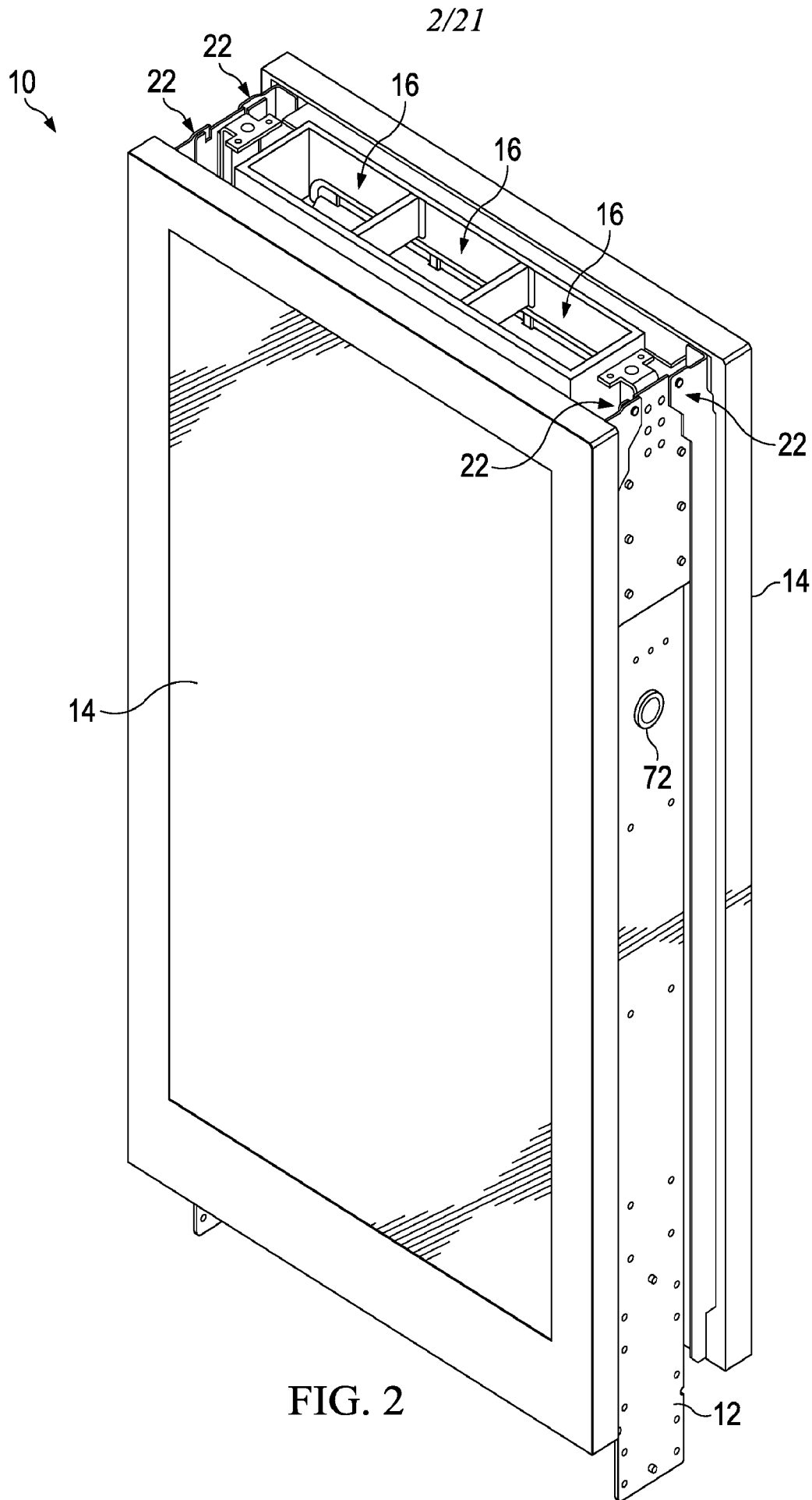

FIG. 2

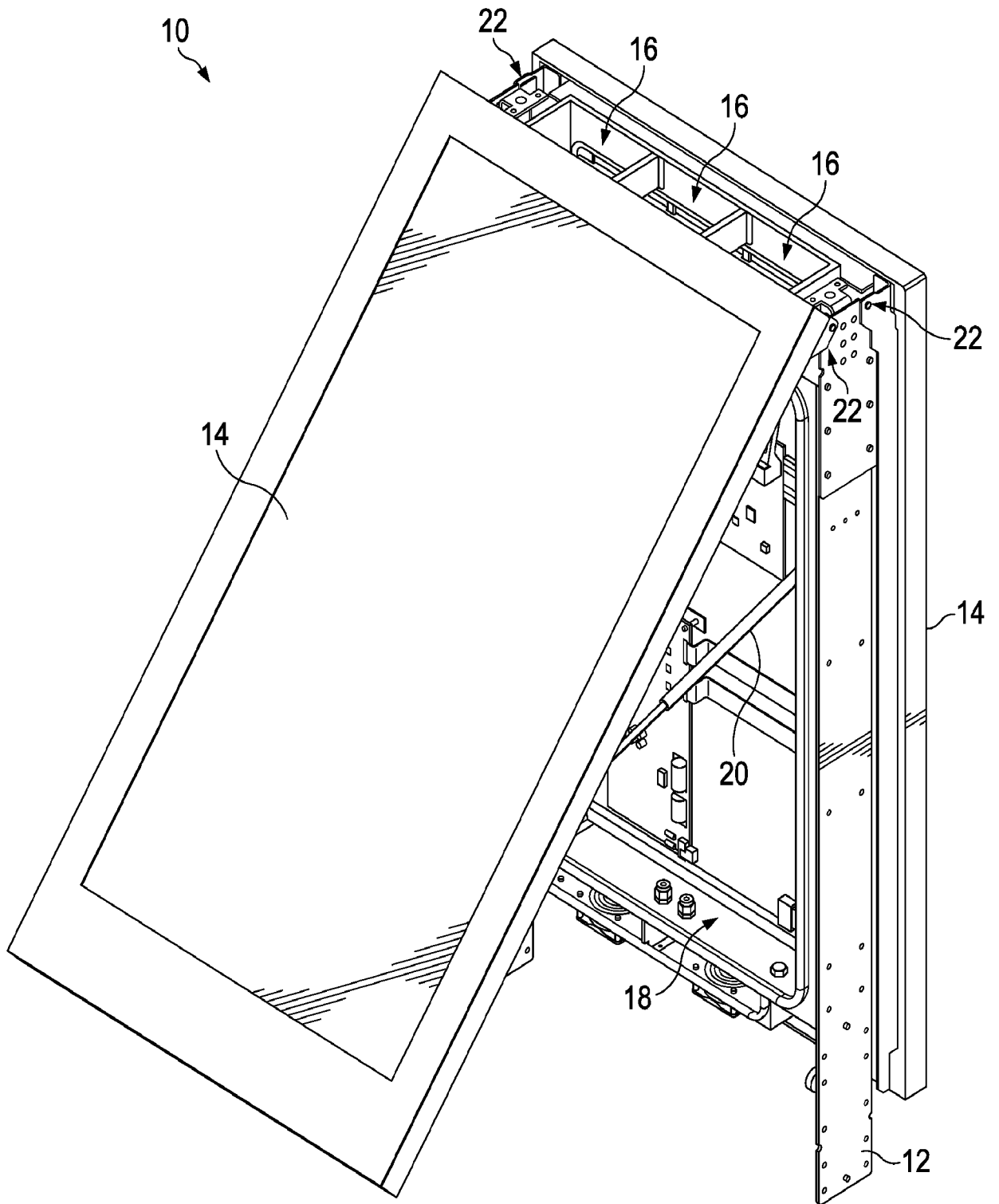

FIG. 3

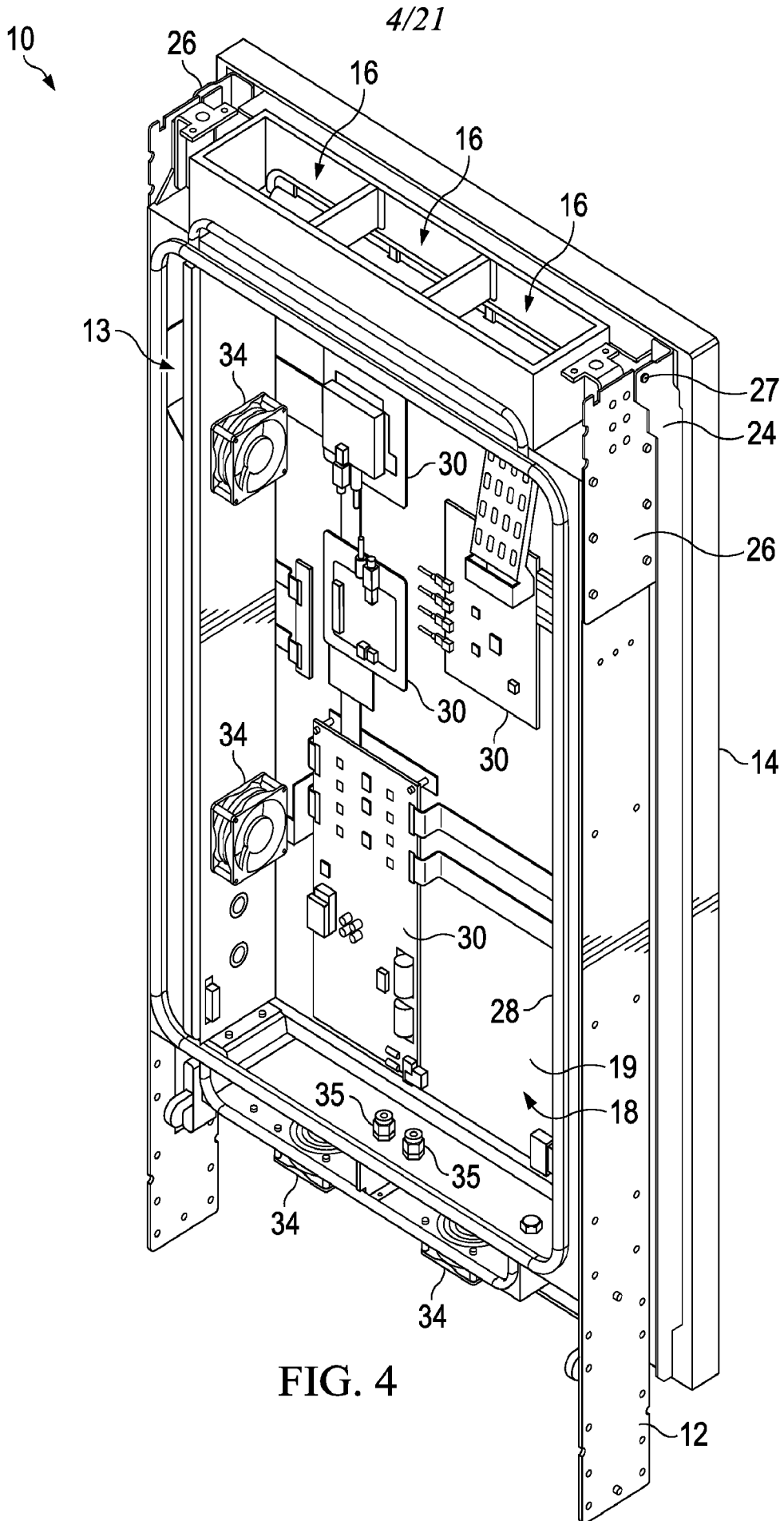

FIG. 4

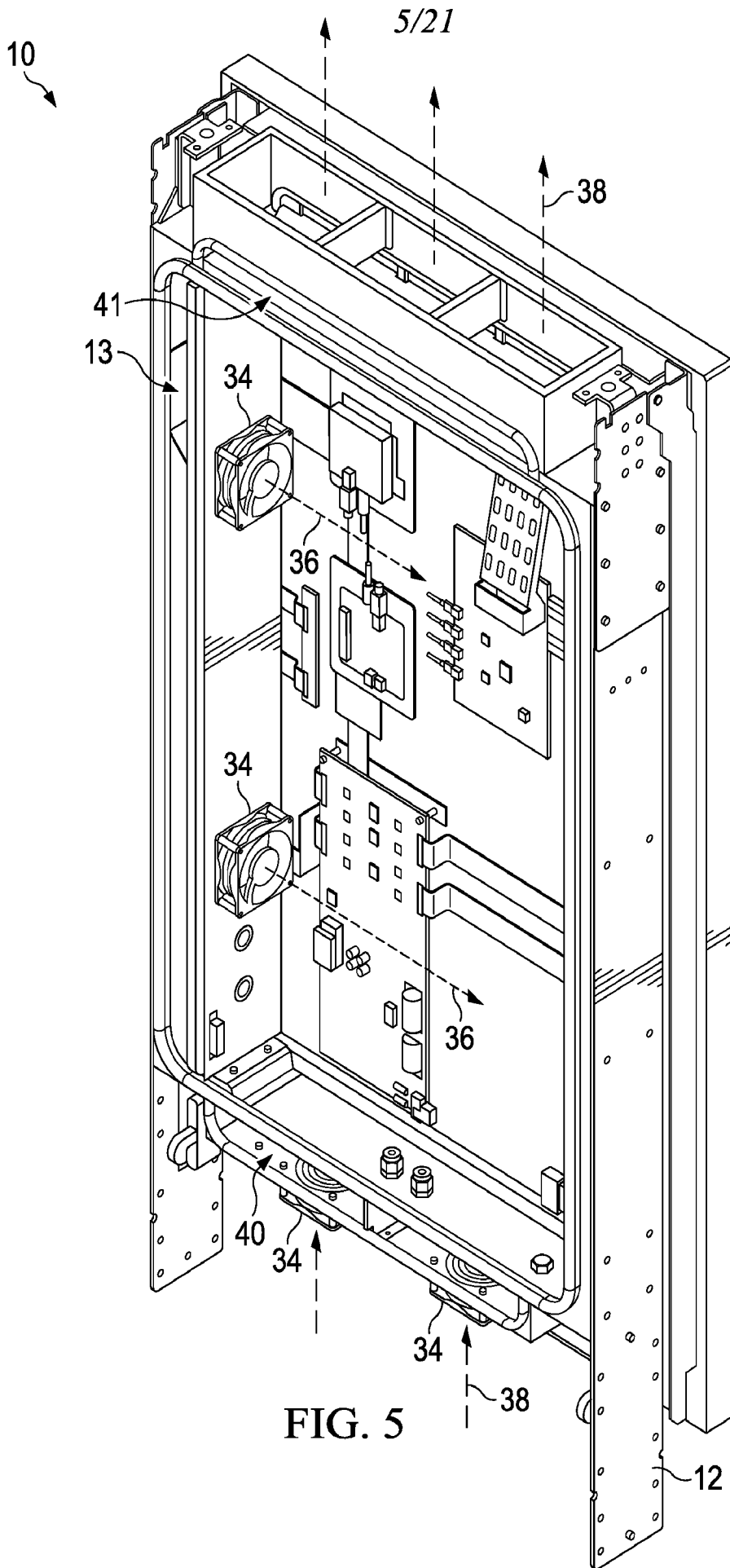

FIG. 5

6/21

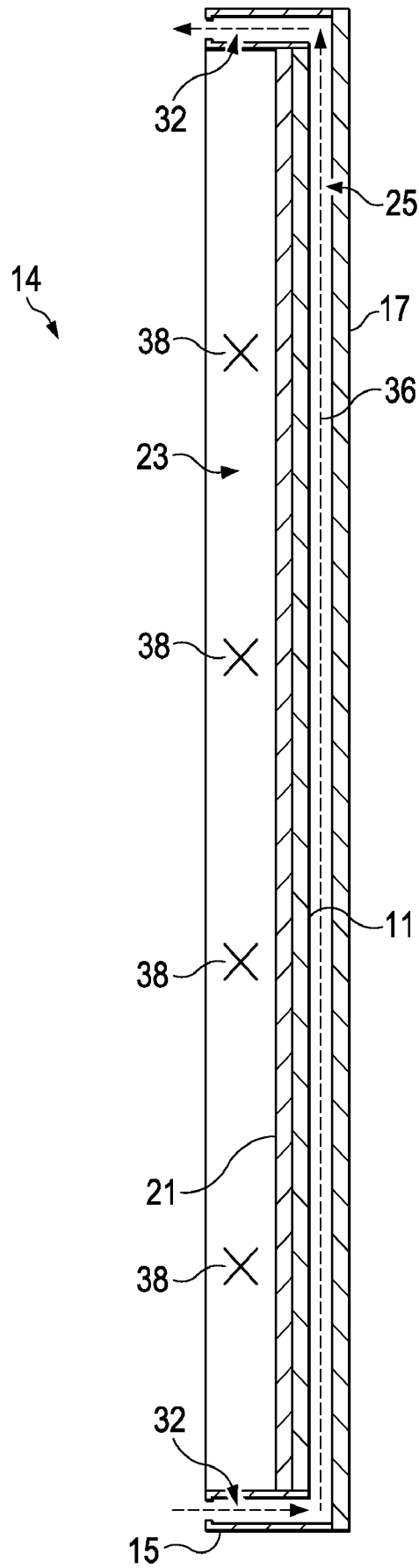
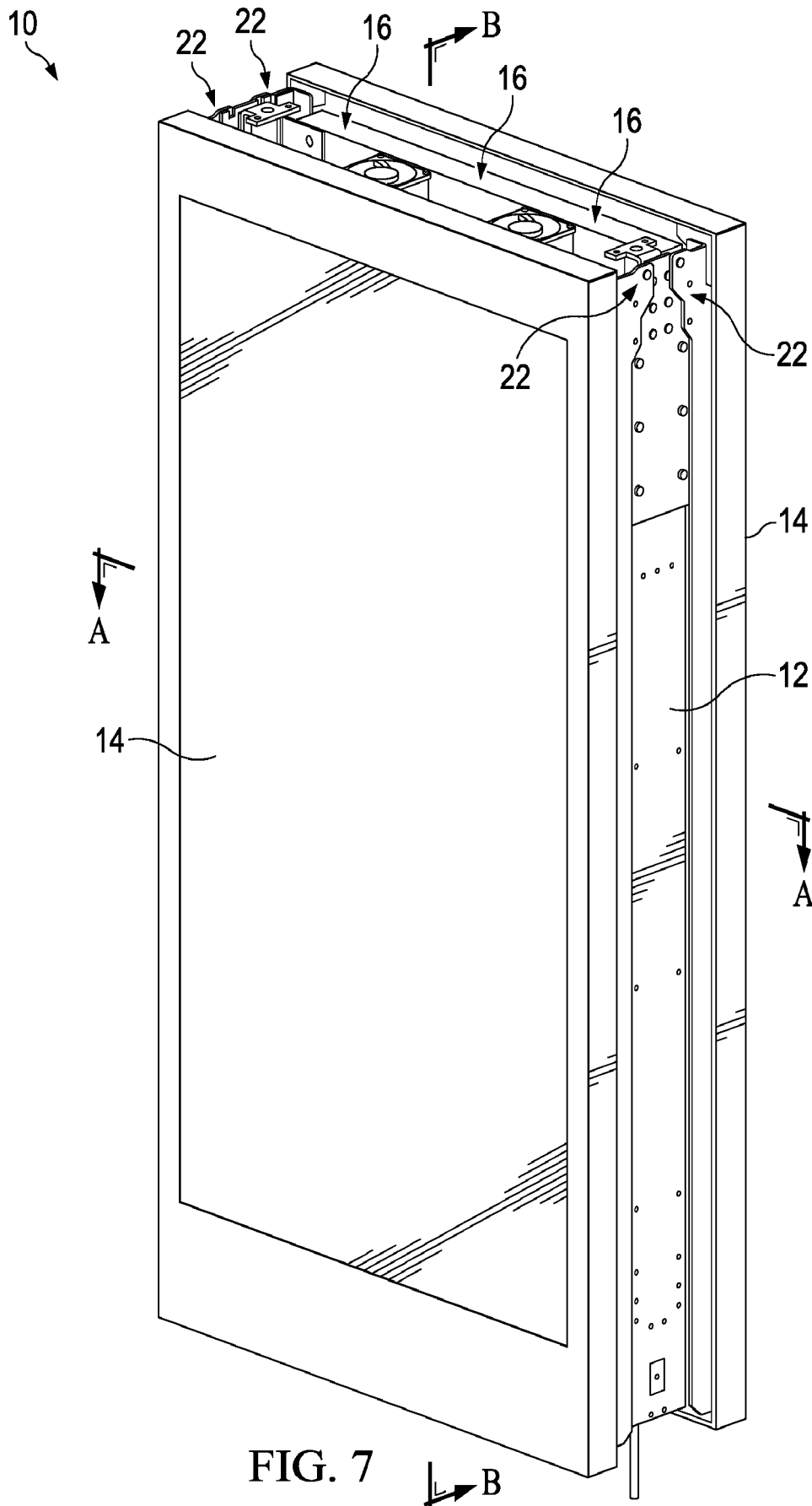

FIG. 6

7/21



8/21

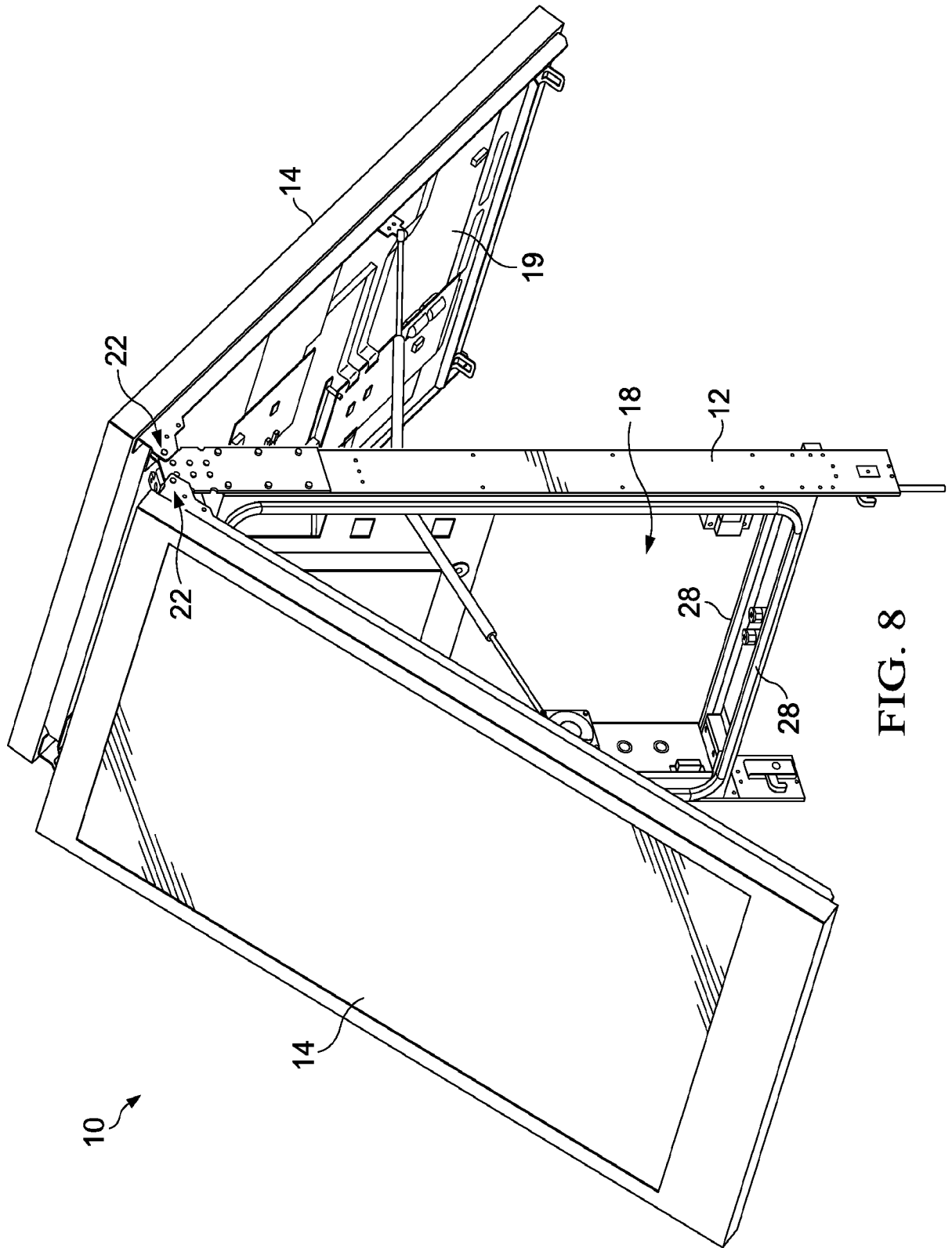
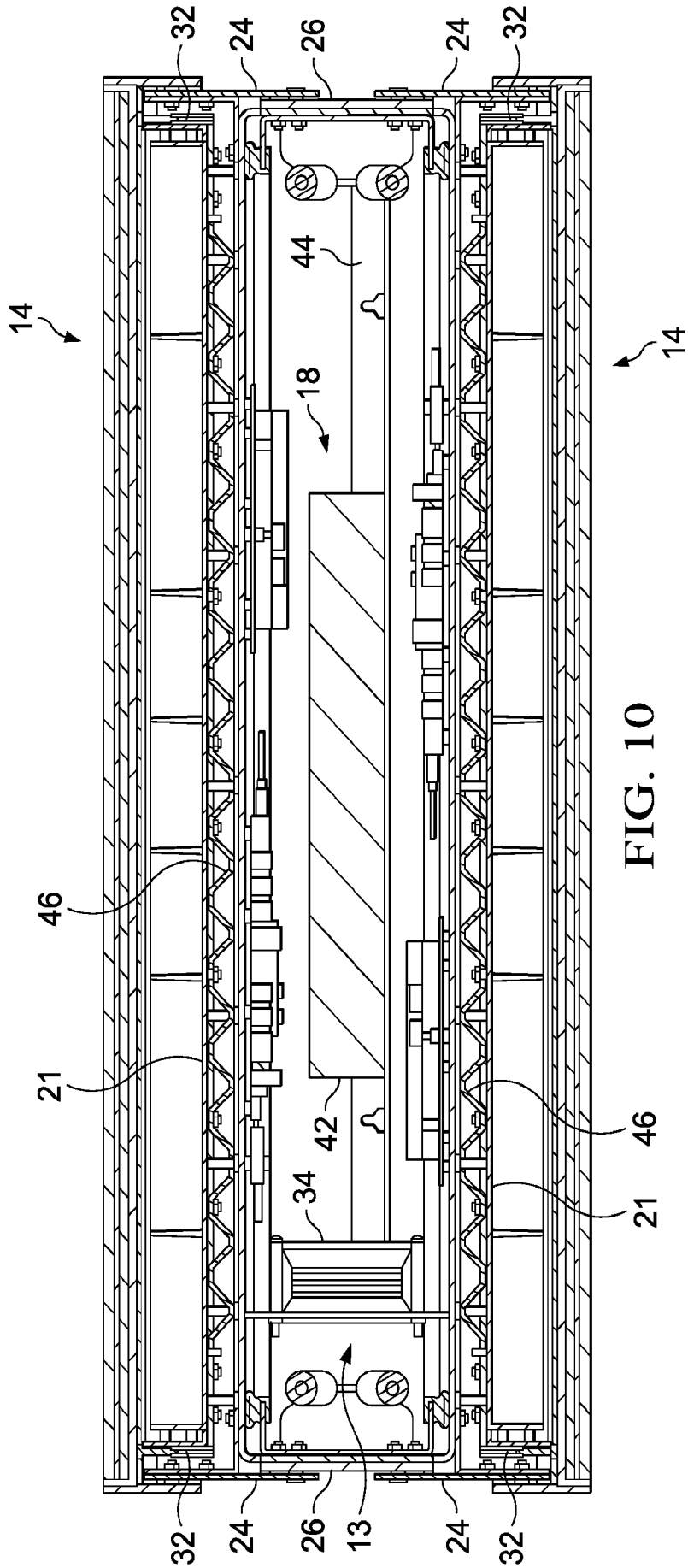

FIG. 8

10/21



11/21

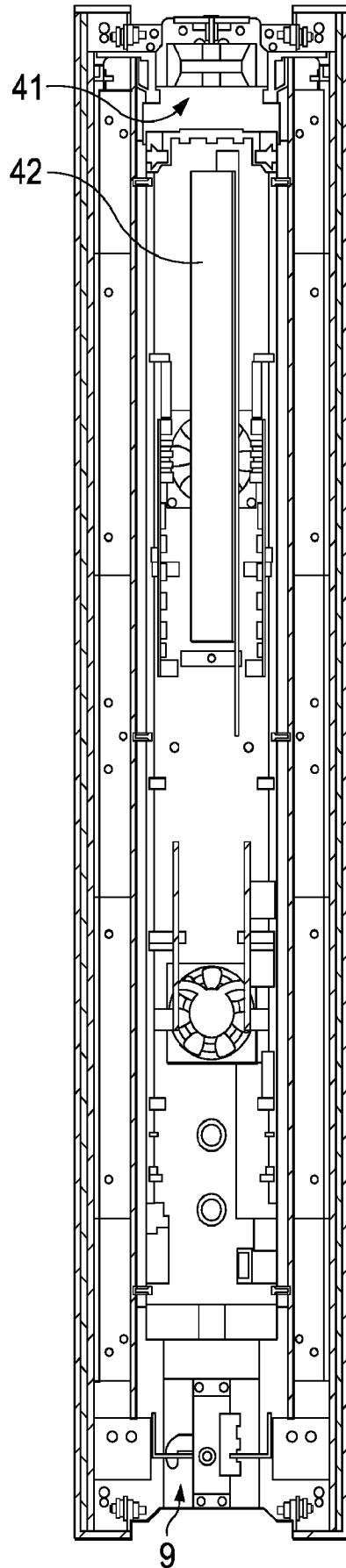

FIG. 11

12/21

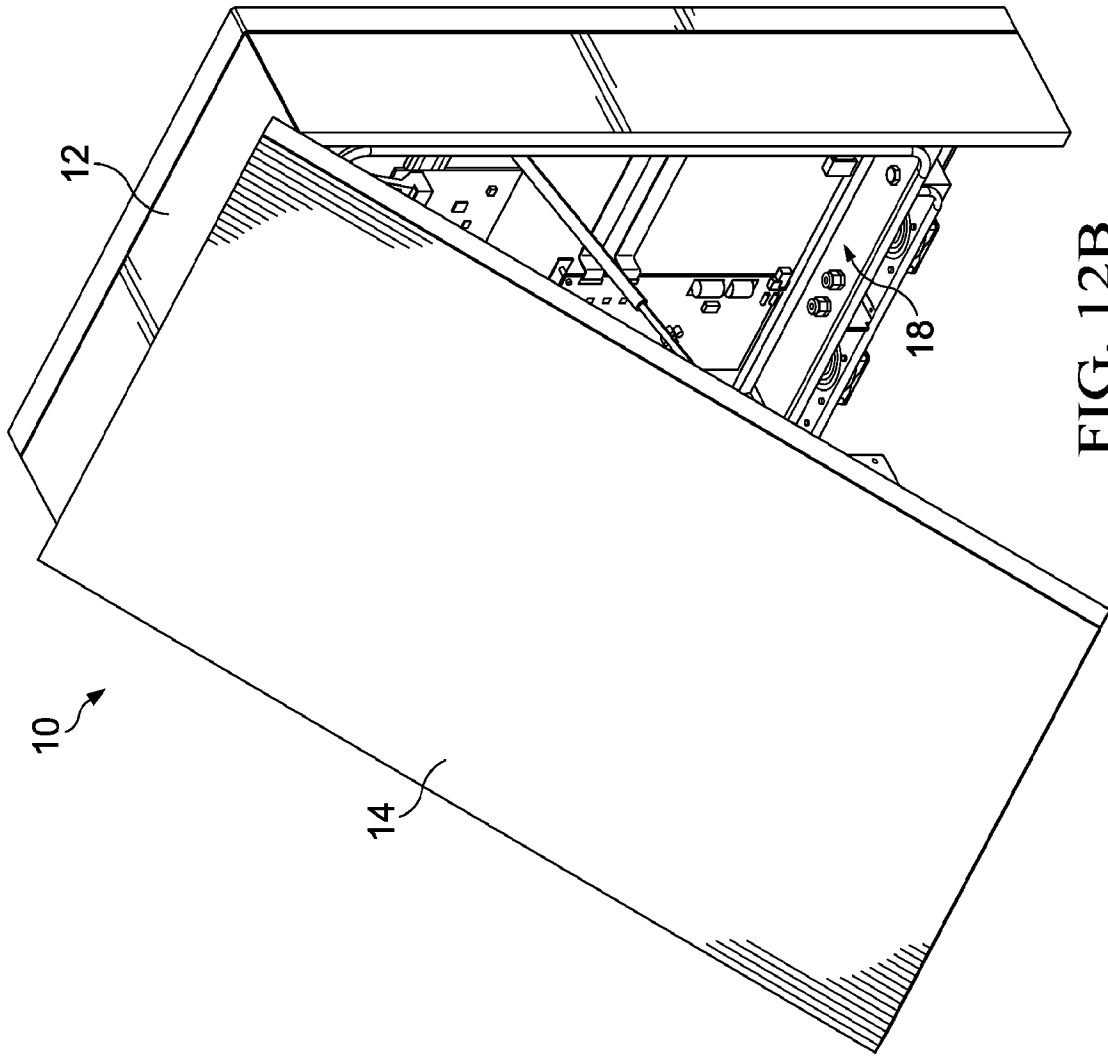

FIG. 12B

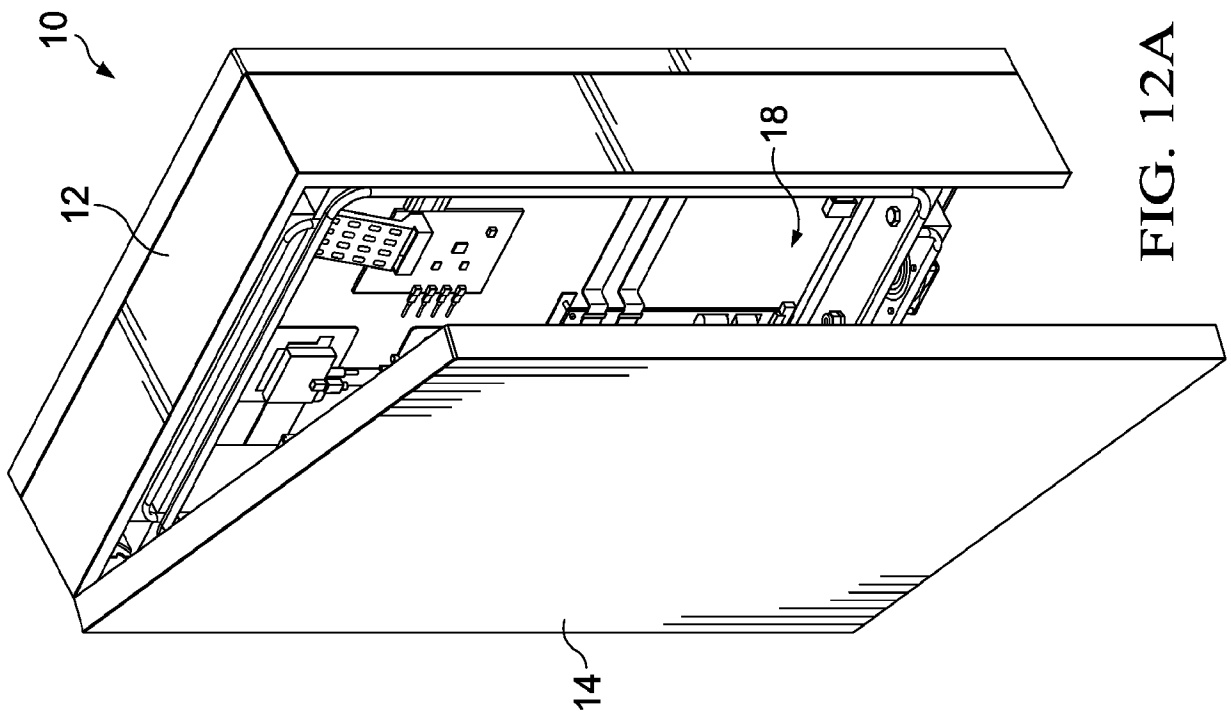

FIG. 12A

13/21

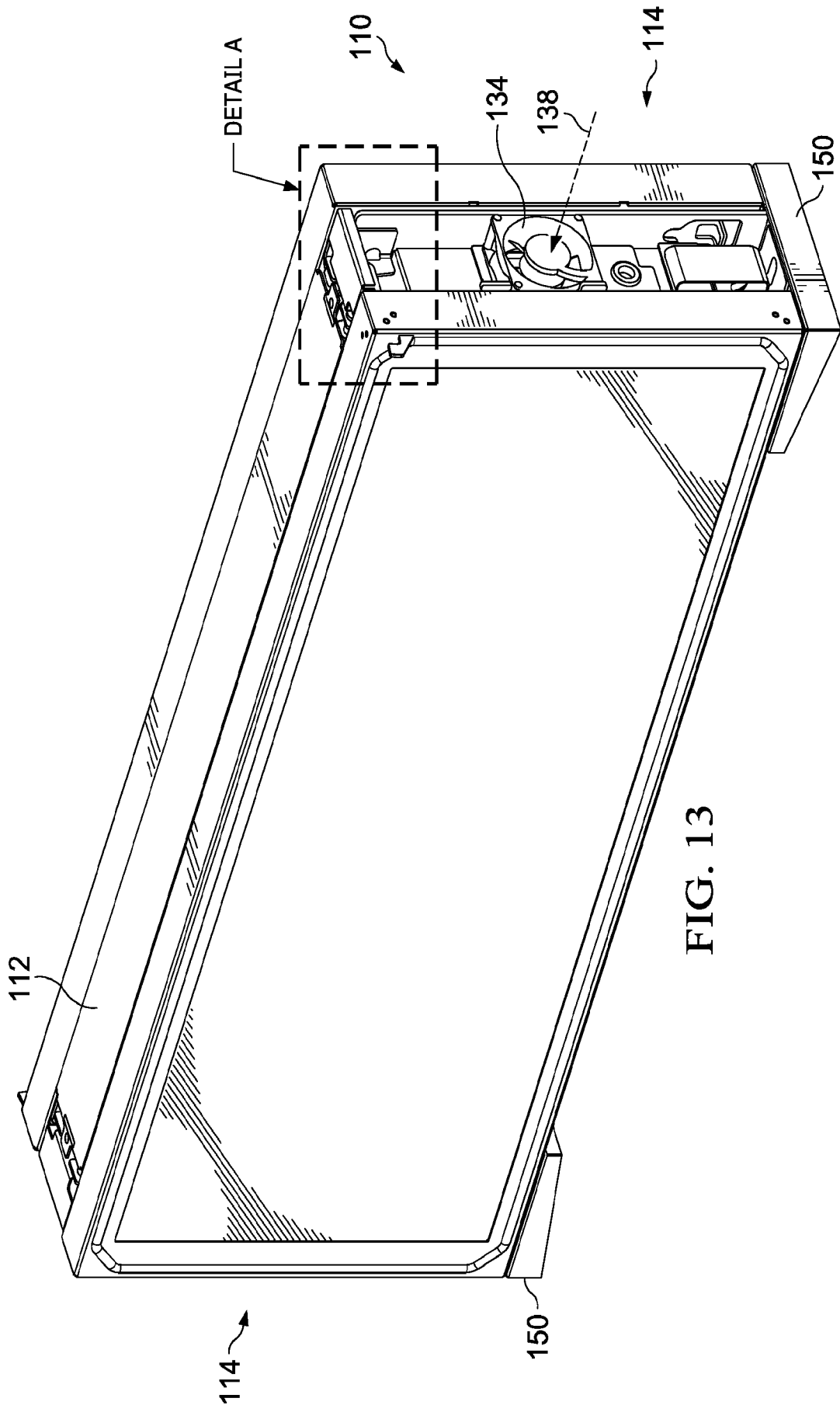

FIG. 13

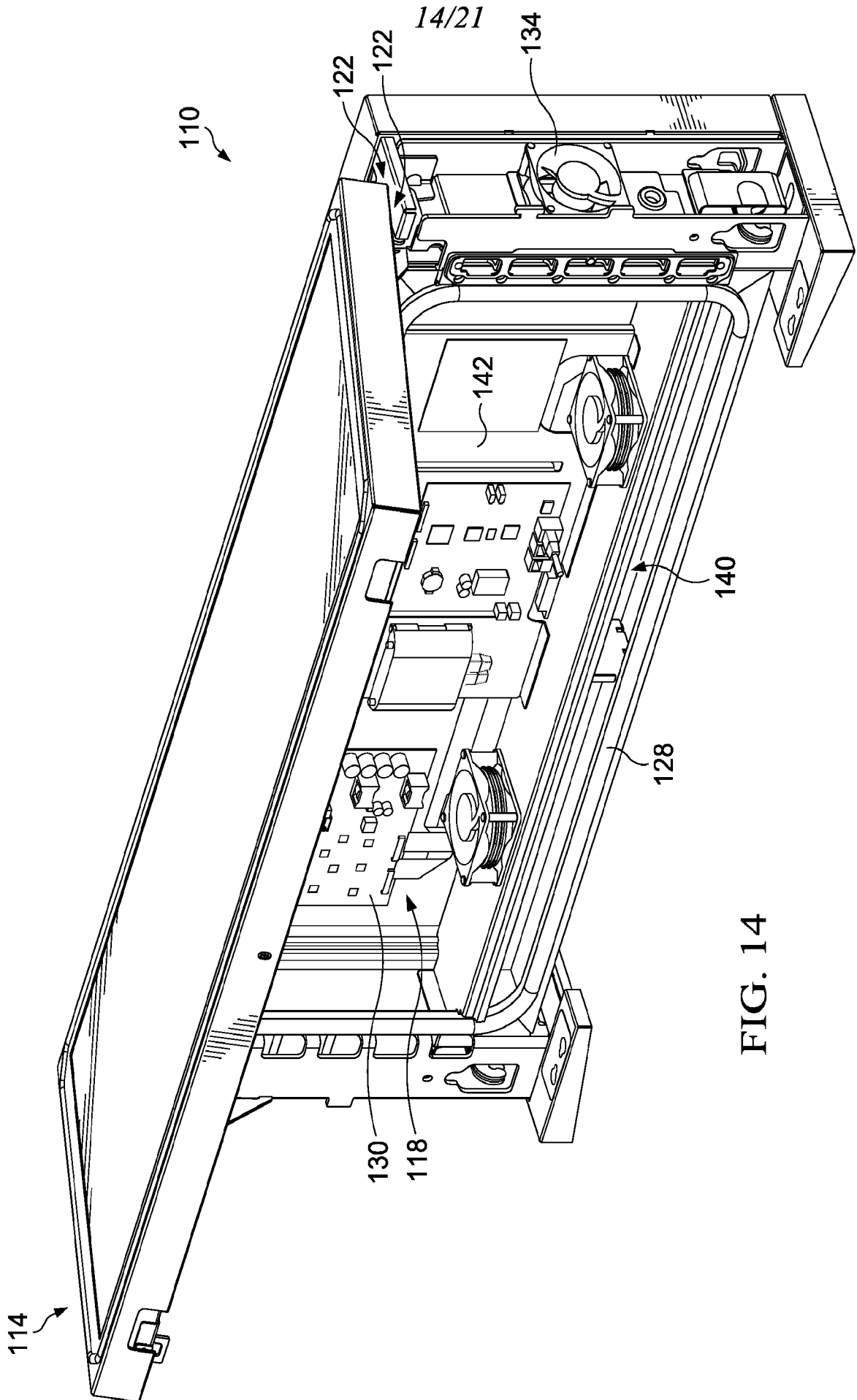

FIG. 14

15/21

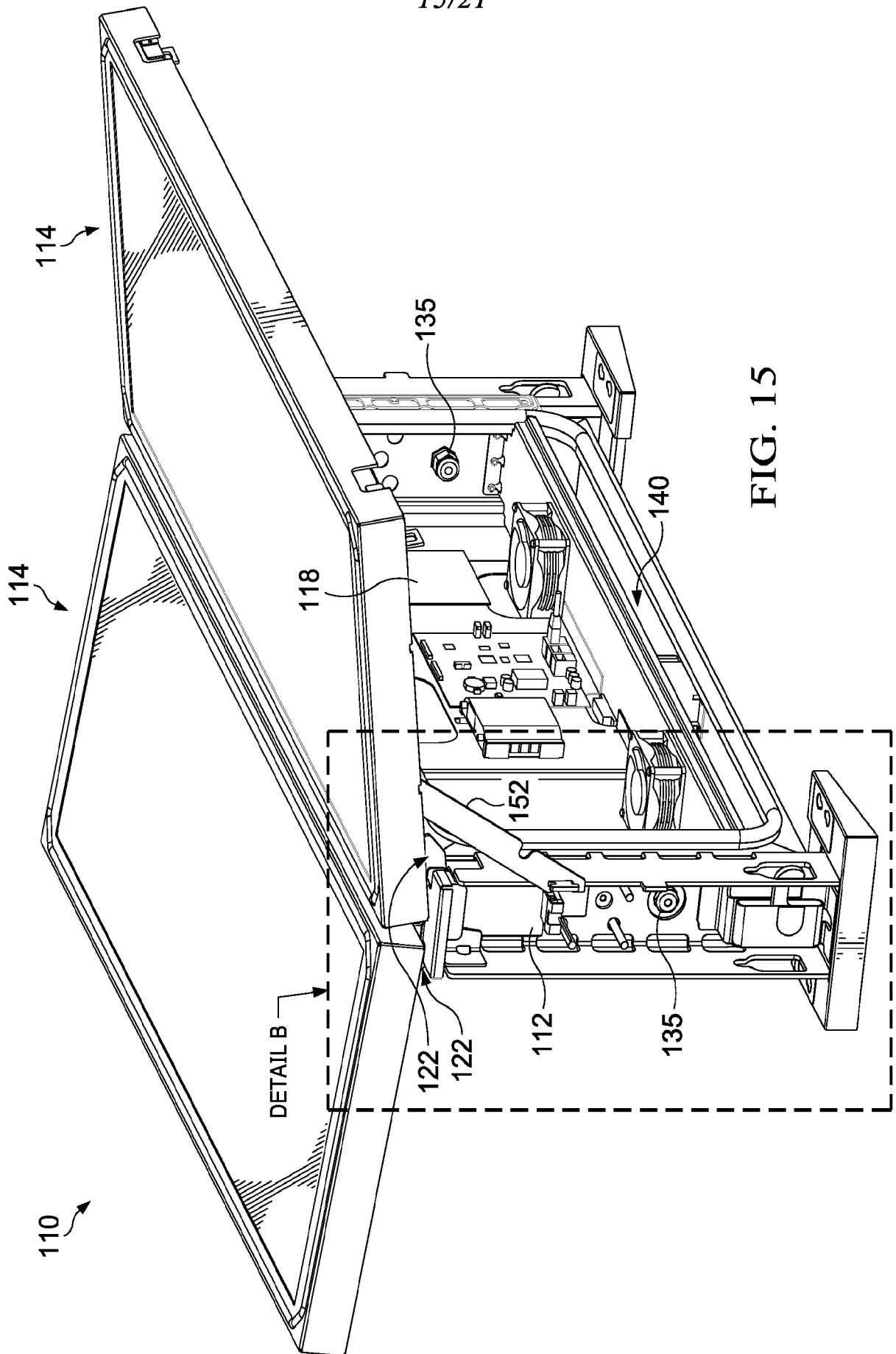

FIG. 15

16/21

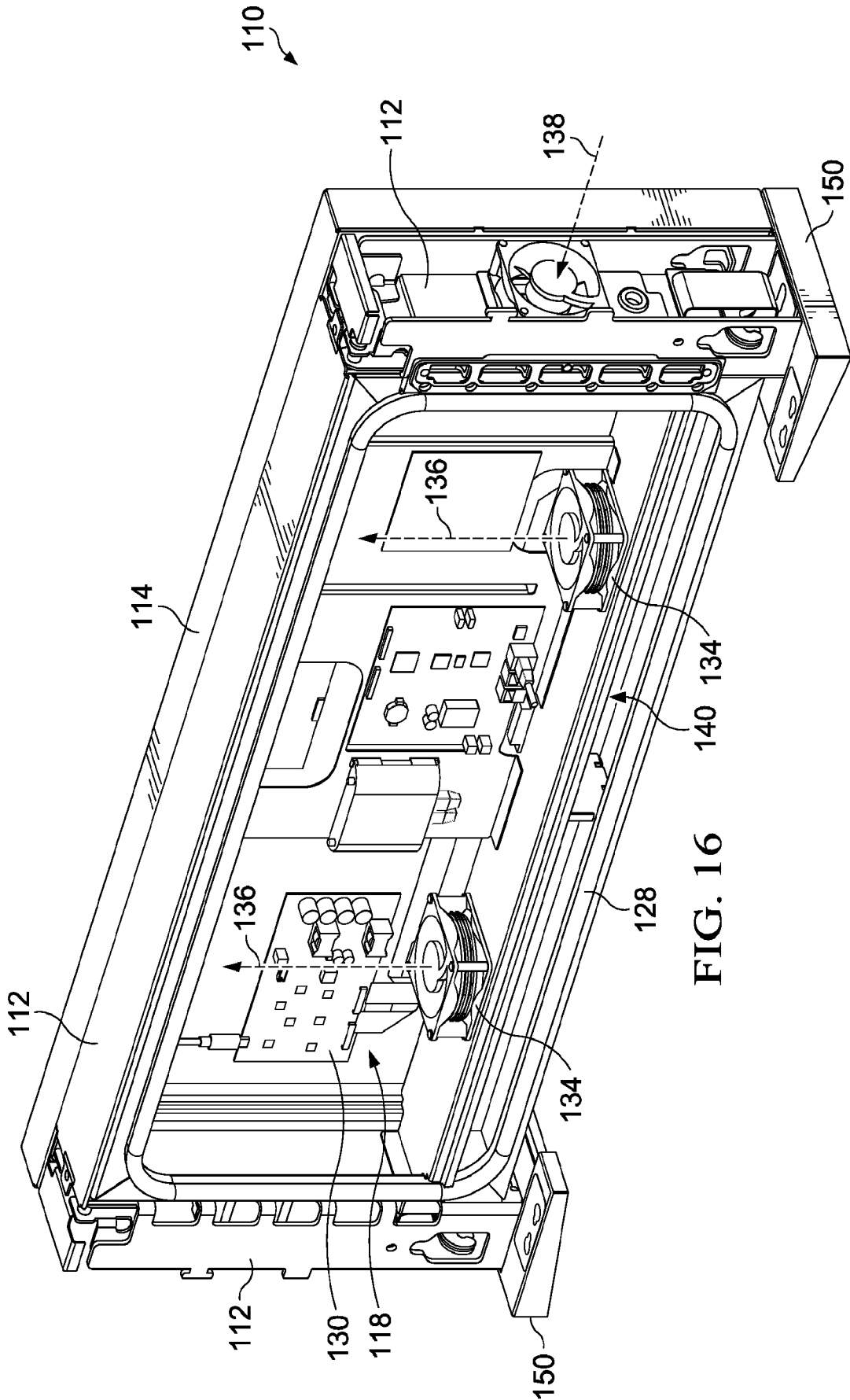

FIG. 16

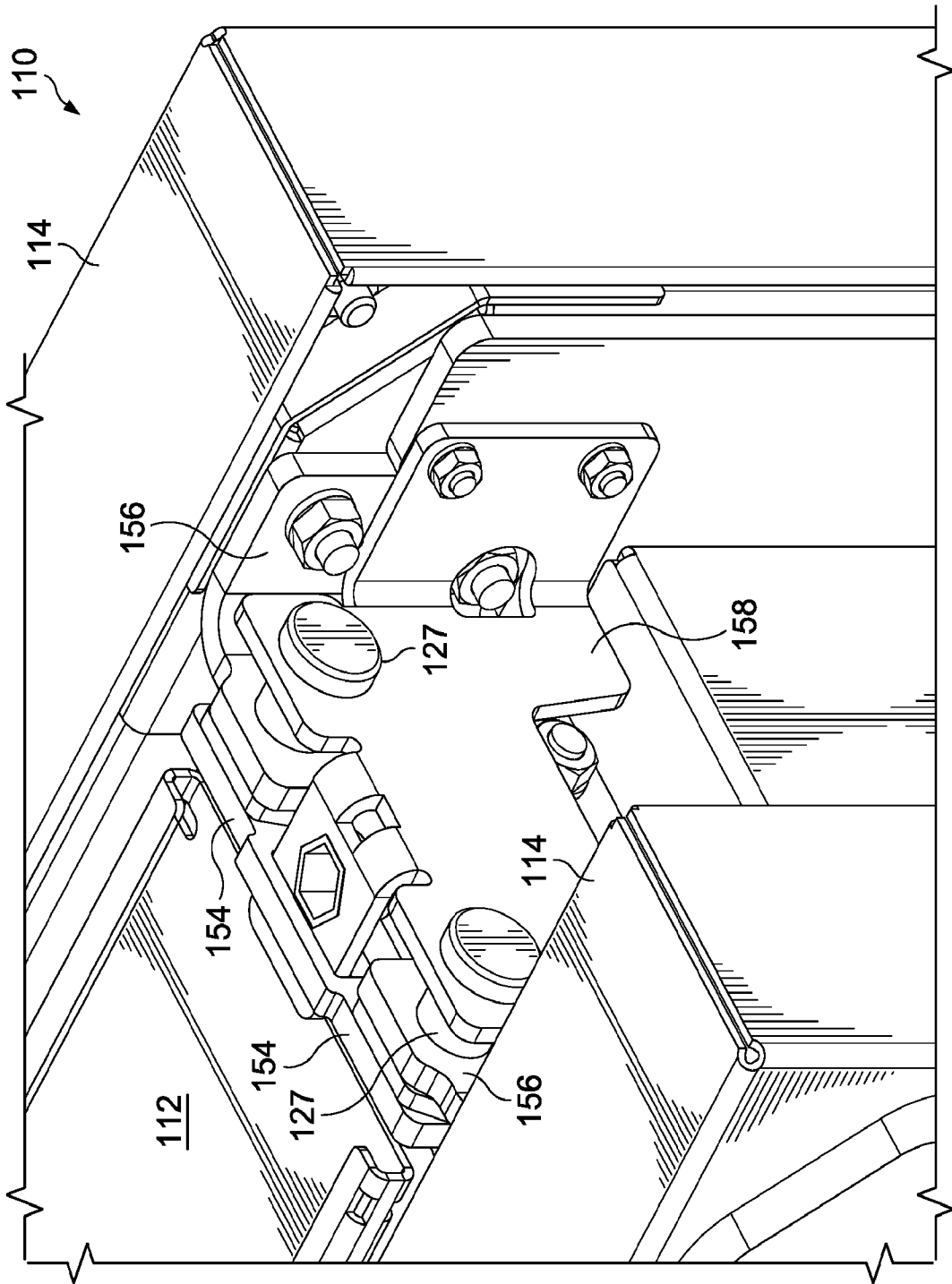

FIG. 17

18/21

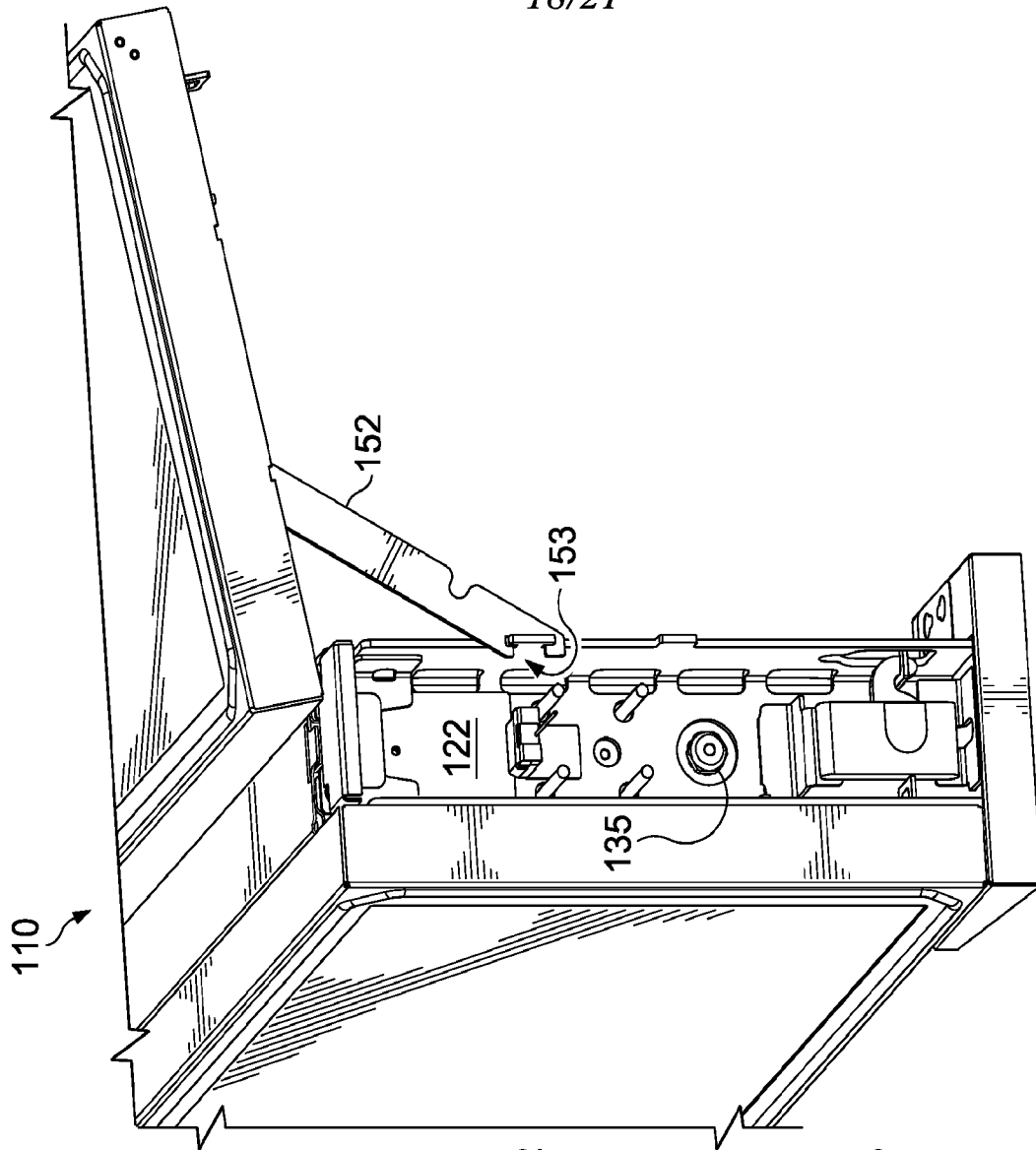

FIG. 18B

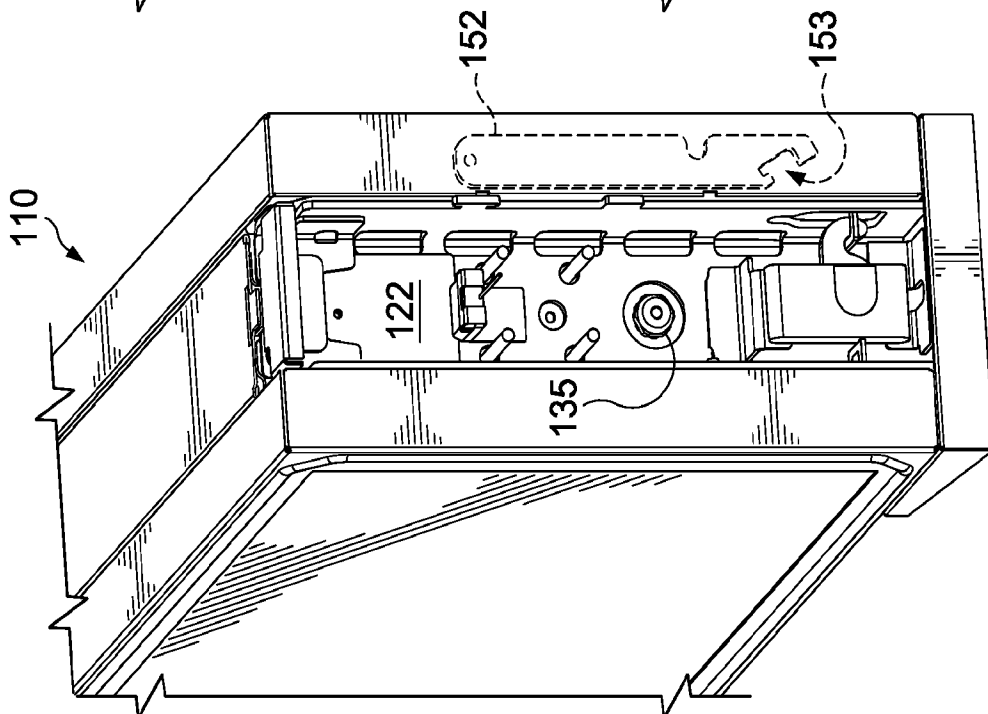

FIG. 18A

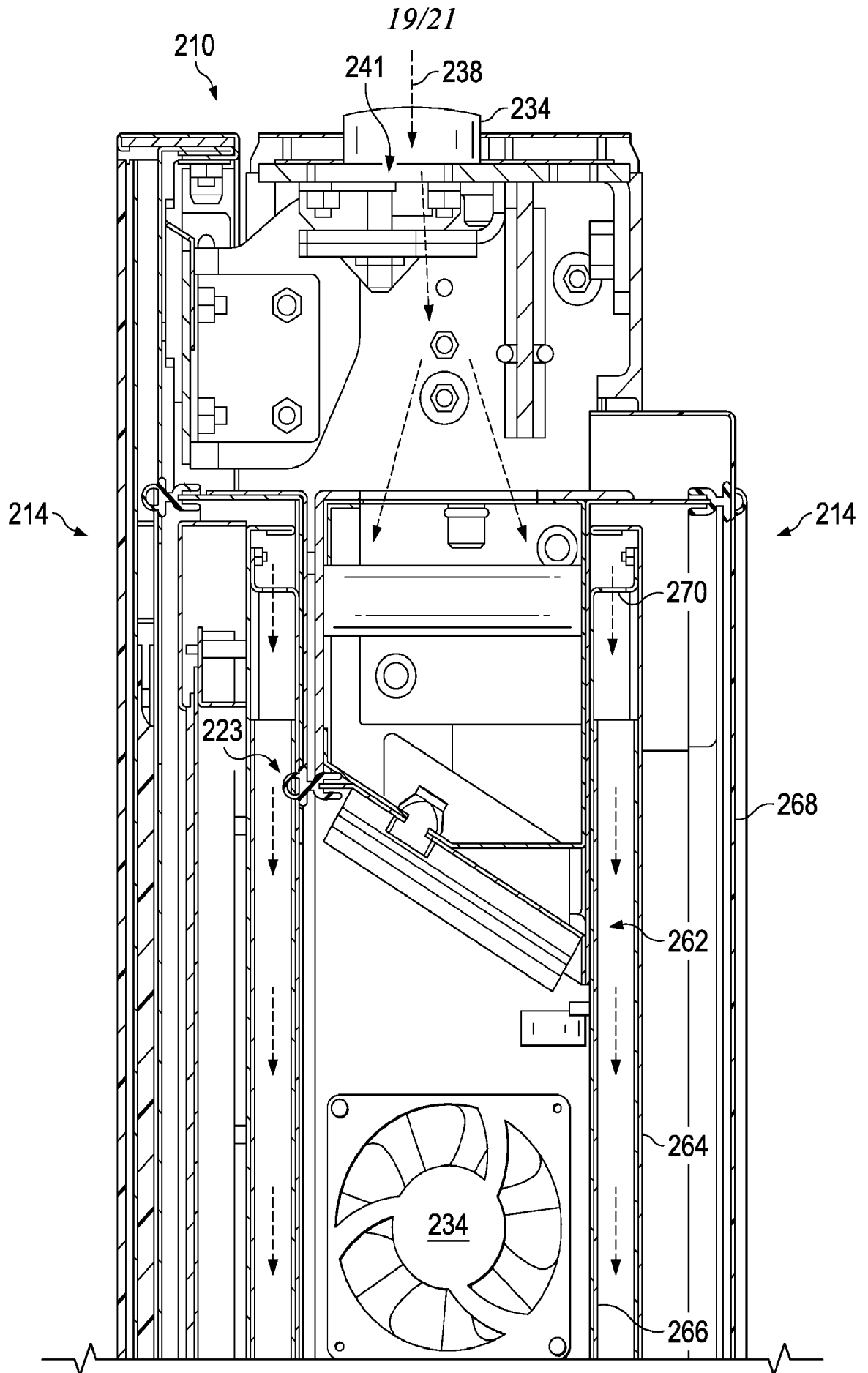

FIG. 19A

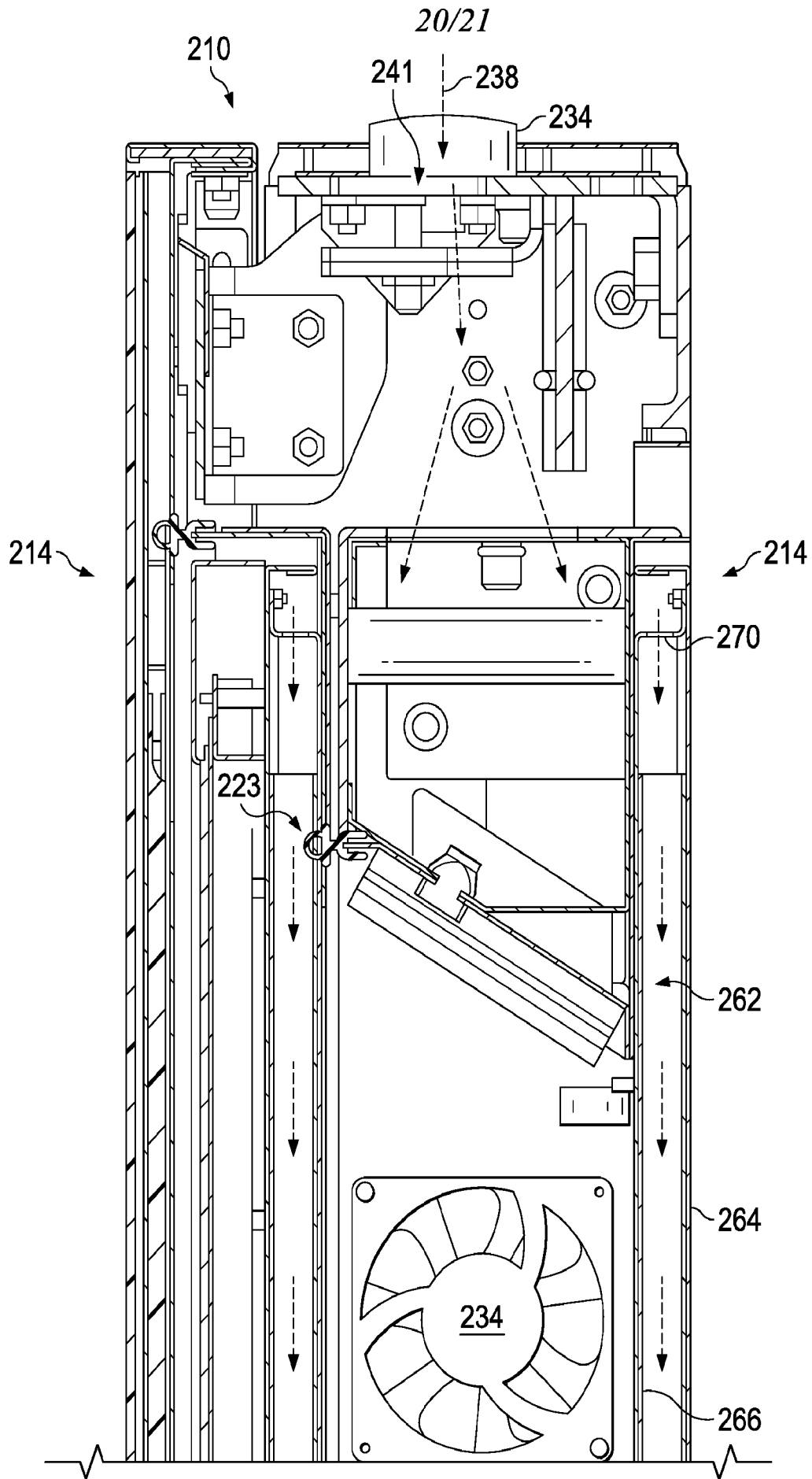

FIG. 19B

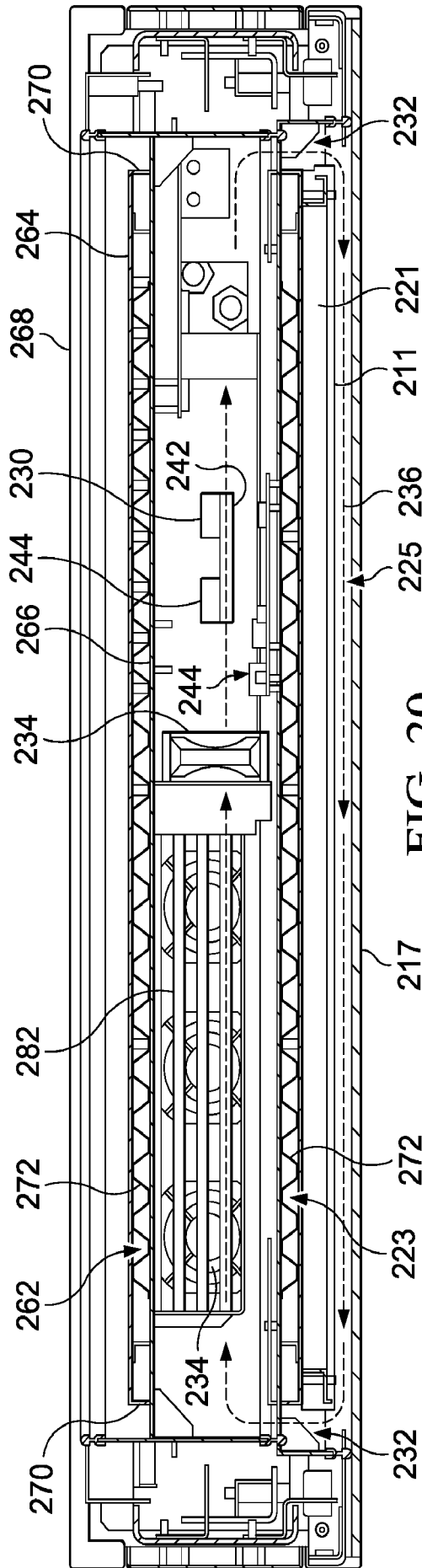

FIG. 20