

J. R. DUBOIS.

Improvement in Dumping-Cars.

No. 132,818.

Patented Nov. 5, 1872.

Fig. 1.

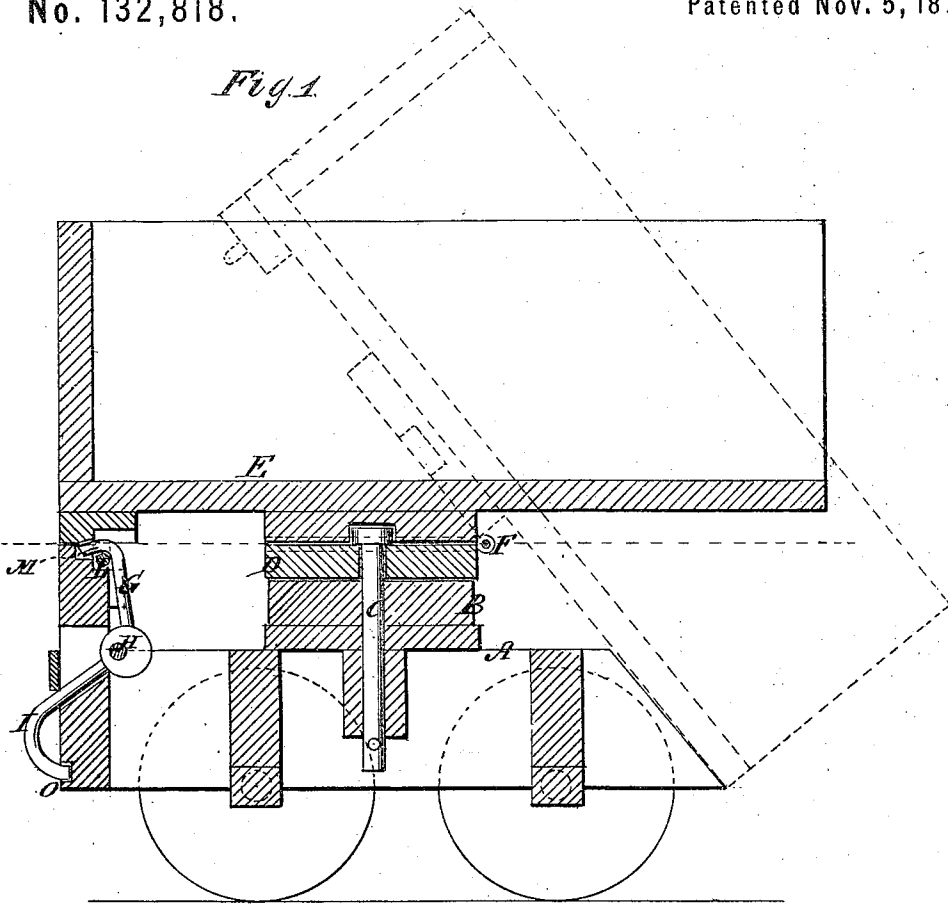
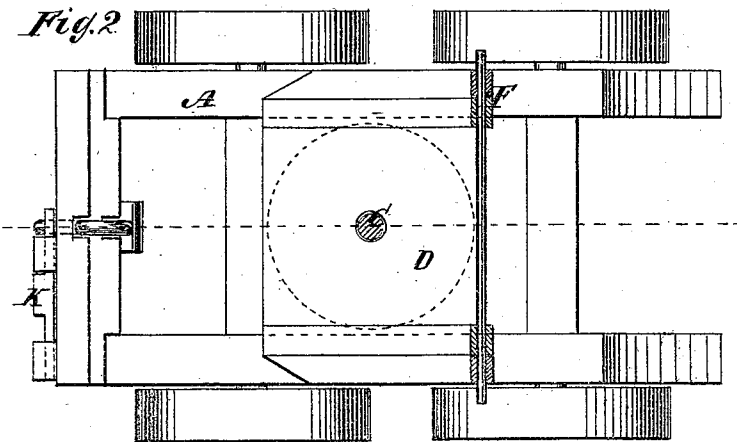

Fig. 2.



Witnesses:

E. Wolff.  
C. Sedgwick

Inventor:

J. R. Dubois  
PER *Wm. H. [Signature]*  
Attorneys.

# UNITED STATES PATENT OFFICE.

JOHN R. DUBOIS, OF VIRGINIA CITY, NEVADA.

## IMPROVEMENT IN DUMPING-CARS.

Specification forming part of Letters Patent No. 132,818, dated November 5, 1872.

*To all whom it may concern:*

Be it known that I, JOHN ROSWELL DUBOIS, of Virginia City, in the county of Storey and State of Nevada, have invented a new and Improved Dumping-Car, of which the following is a specification:

My invention relates to improvements in the class of dumping-cars in which the box is hinged and pivoted so as to be turned horizontally and also be tilted toward either side or end of the truck; and it consists in the peculiar arrangement of locking devices for preventing the box from swinging around on the turn-table at the same time that it is held from tilting.

Figure 1 is a longitudinal sectional elevation of my improved dumping-car with the box shown in dotted lines in the position it occupies after dumping, and Fig. 2 is a horizontal section taken on the line *xx* of Fig. 1.

Similar letters of reference indicate corresponding parts.

A is the truck-car, with a small platform, B, at the center, or a little in advance of it, with a strong king-bolt, C, extending through its vertical center and through a turn-table, D,

which is thereby pivoted to said platform so as to revolve horizontally; and to this table the box E is hinged, as shown at F. At one end I have arranged a hook, G, on an oscillating shaft, H, with an arm, I, projecting through the front end of the platform in such manner as to be secured to lock the car-box by a sliding bar or bolt, K, which slides in front of it, to hold the hook G in the staple L of the box; also in a socket, M; and also to hold the lower end in a socket, O, in the car-body, in such manner as to effectually hold the car-box from swinging or turning on the pivot while it is locked.

Having thus described my invention, I claim as new and desire to secure by Letters Patent—

The hook-lever G H I applied to box E and truck A M O, in combination with a staple, L, and lock-bolt K, as and for the purpose described.

JOHN ROSWELL DUBOIS.

Witnesses:

WILL. H. BURRALL,  
JOHN H. KETTELL.