

A. CROSBY.  
Vacuum Dredger.

No. 203,892.

Patented May 21, 1878.

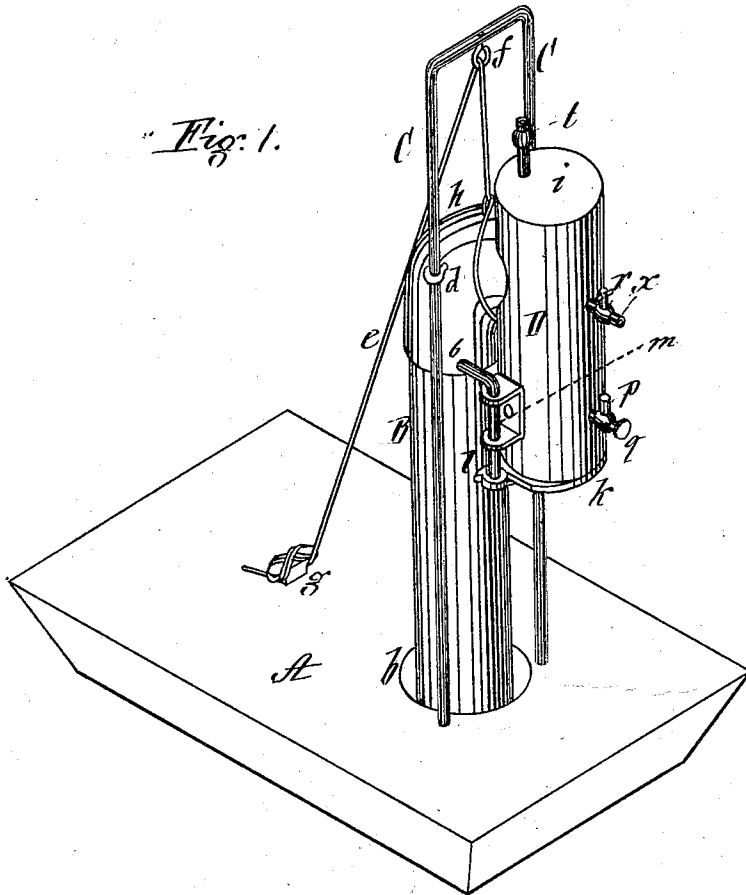
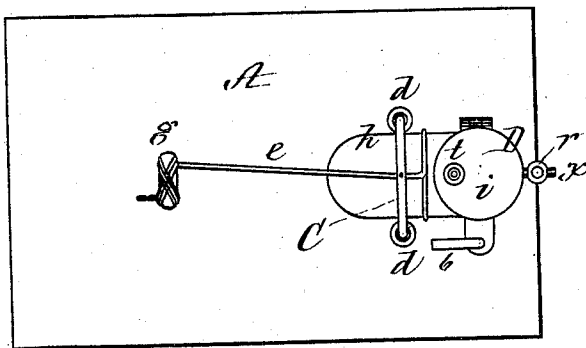

Fig. 3.



Witnesses,  
 W. Cambridge  
 J. E. Cambridge

Inventor,  
 Augustine Crosby,  
 Per Teschemacher & Stearns,  
 Attorneys.

A. CROSBY.  
Vacuum Dredger.

No. 203,892.

Patented May 21, 1878.

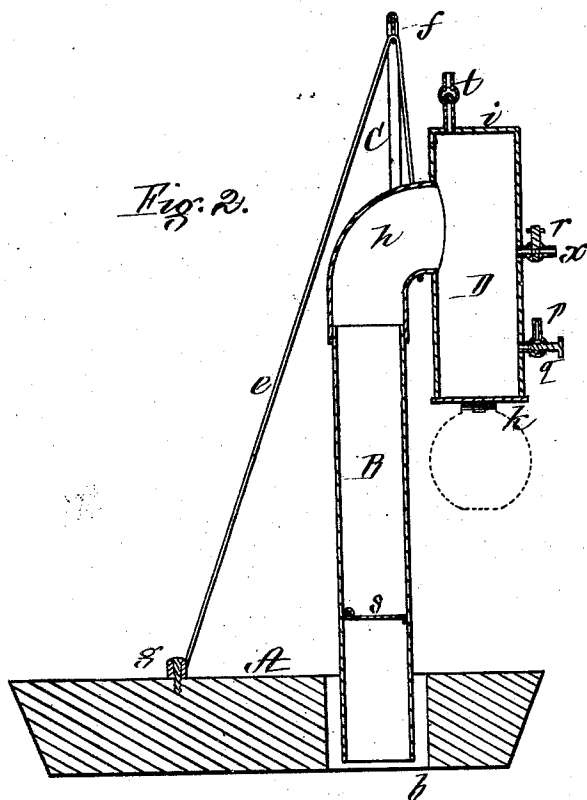

Fig. 4.

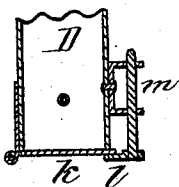

Fig. 5.



Witnesses,  
W. J. Cambridge  
J. C. Cambridge

Inventor,  
Augustine Crosby,  
Per Teschemacher & Stearns,  
Attorneys.

# UNITED STATES PATENT OFFICE.

AUGUSTINE CROSBY, OF BENTON, MAINE.

## IMPROVEMENT IN VACUUM-DREDGERS.

Specification forming part of Letters Patent No. 203,892, dated May 21, 1878; application filed November 27, 1877.

To all whom it may concern:

Be it known that I, AUGUSTINE CROSBY, of Benton, in the county of Kennebec and State of Maine, have invented an Improvement in Vacuum Dredging-Machines, of which the following is a full, clear and exact description, reference being had to the accompanying drawings, making part of this specification, in which—

Figure 1 is a perspective view of my improved vacuum dredging-machine. Fig. 2 is a vertical section through the center of the same. Fig. 3 is a plan; Fig. 4, sectional detail; Fig. 5, detail in perspective.

Vacuum dredging-machines as heretofore constructed are objectionable, for the reason that the long tube or receiver into which the mud is forced by the pressure of the atmosphere after a vacuum has been produced therein requires to be lifted sufficiently to bring its lower end above the surface of the water in order to discharge the mud, &c., previously forced therein. This raising of the receiver, which is necessarily of great weight when filled, requires the employment of heavy and expensive machinery and powerful engines, the operation of which soon strains and injures the scow or platform on which the apparatus is placed, and necessitates frequent repairs.

This invention relates to an improvement in such vacuum dredging-machines; and has for its object to simplify their construction and increase their efficiency; and consists in providing the vacuum-chamber of the receiver with a direct outlet at its bottom, through which the mud, &c., is discharged, a movable cover or gate being applied to the open bottom of the chamber in such manner as to allow of its being closed air-tight while the mud is being raised.

To enable others skilled in the art to understand and use my invention, I will proceed to describe the manner in which I have carried it out.

In the said drawings, A represents the scow or platform on which the apparatus is placed. B is the receiver, consisting of a strong metal tube open at the lower end, and of sufficient length to reach and penetrate to the desired depth the mud or gravel to be removed by

the dredging operation. This receiver B passes through a suitable well or opening, *b*, in the scow or platform, and is steadied and held in an upright position by a frame, C, to which it is connected by means of eyes or guides *d d*, which slide upon the vertical standards of the frame, the receiver B being held up in the position seen in Fig. 1 when the apparatus is not in use, or is being moved from place to place, by a rope or chain, *e*, attached thereto, and passing through a pulley, *f*, at the top of the frame, down to the deck of the scow, where it is belayed to a cleat, *g*.

The upper end of the receiver B is connected by a bent piece or elbow, *h*, with a vertical cylinder, D, which forms a chamber or receptacle for the mud, gravel, &c., which is forced up through the receiver B in a manner to be presently described.

The upper end of the cylinder D is closed by a tight head, *i*, its lower end, which is open, being provided with a hinged gate or covering-plate, *k*, which is made to fit the bottom of the cylinder with an air-tight joint, and is confined, when closed, by means of a catch or wedge-shaped projection, *l*, on a short vertical shaft, *m*, which may be turned, by means of its handle *n*, to cause the projection to lock or release the cover *k*.

Near the lower end of the cylinder D is a short pipe, *p*, provided with a valve or stop-cock, *q*, it being intended to connect this pipe *p* with a suitable steam-generator (not shown) by means of a flexible pipe of sufficient length to allow of the descent of the receiver.

Above the pipe *p* is another short pipe, *x*, also provided with a valve or stop-cock, *r*, it being intended to connect this pipe *x*, by means of a flexible pipe of suitable length, with a water tank or reservoir, or other source of supply, from from which the water can be introduced within the cylinder under pressure.

Within the receiver B, near its lower end, is located a flap-valve, *s*, which is so arranged that it will open inwardly to allow of the free upward passage of the mud, &c., but will close to prevent its escape downward.

The operation of my improved dredging-machine is as follows: The screw A having been brought into the desired position, the rope *e* is released and the receiver B lowered

until its bottom rests upon the mud or gravel to be removed. The cover *k* of the cylinder D being tightly closed the valve *q* is opened, and steam, under suitable pressure, is admitted to the cylinder D and receiver B, the air therein being expelled through a "snifting" or escape valve, *t*, at the top of the cylinder D, which is constructed to be closed by pressure from the outside. As soon as the air has been driven out and steam begins to escape from the valve *t*, the steam-valve *q* is closed and the valve *r* opened to admit a stream or jet of water, which instantly condenses the steam and produces a vacuum within the cylinder D and receiver B, the valve *t* being closed by the pressure of the external atmosphere. As soon as a vacuum is produced within the cylinder D and receiver B, as above described, the atmospheric pressure acting upon the surface of the water causes the mud, gravel, &c., to be forced up the receiver B, and thence through the curved portion *h* into the chamber D, which is thus filled as desired; and, as this chamber is located out of line with the receiver B, it is impossible for the mud, &c., to return thereto on the readmission of air. The gate *k* is now unlocked by turning the handle 6, when it will drop down on its hinge and allow the contents of the chamber D to be discharged through the open end, air or steam being admitted at the top of the cylinder by a suitable valve, if desired, to facilitate this operation.

When the gate *k* is opened, and air thereby admitted into the upper end of the receiver B, the mud, &c., therein is retained in place by the valve *s*, which is closed automatically by the weight of the mud, &c., above it. As soon as the contents of the chamber D have been discharged, the gate *k* is closed and locked by turning the handle 6, and the operation of filling the chamber D is repeated, the receiver B settling down by its own weight as fast as the mud is removed, and when the desired depth has been reached, the receiver B is drawn up by means of the rope or chain *e*, and again lowered in a contiguous place; but when the nature of the bed being dredged will admit of it, the scow or platform can be moved without raising the receiver B as soon as the desired depth has been reached.

The rope or chain *e* may be attached to a windlass operated by hand, or steam-power may be employed, if preferred, for raising the

receiver; but it will be seen that the only steam absolutely necessary to successfully operate the apparatus is that required for producing a vacuum within the receiver B and its chamber D, for the reason that the mud, &c., is discharged from the upper end of the receiver, instead of from its bottom, as heretofore, and consequently the expensive machinery, engines, &c., usually required in vacuum dredging-machines to raise the receiver with its contents are rendered unnecessary, thus greatly simplifying the construction of the apparatus and reducing its cost.

In the use of my machine, the receiver B can be passed down through the air-locks of a caisson and its contents be discharged through the upper lock; and my invention can be employed to advantage in floating vessels stranded on sand-banks, &c.

My invention can also be used in driving hollow piling for bridges, canals, breakwaters, mining operations, &c., in which case a cylinder or chamber, D, would be temporarily connected by a bent piece or elbow, *h*, to the top of each hollow pile, which would settle down as the mud was forced up through it in the same manner as the receiver B above described.

I prefer to have the top of the chamber D extend above the elbow *h*, a space being thus left for any air which may remain within the chamber, which air is thus prevented from obstructing the passage of the mud from the receiver B.

What I claim as my invention, and desire to secure by Letters Patent, as an improvement in vacuum dredging-machines, is—

In a vacuum dredging-machine, the receiver B, having at its upper end a vacuum-chamber, D, located out of line with the main portion of the receiver, and provided with a direct outlet at its bottom for the discharge of the mud, &c., in combination with a movable cover or gate, *k*, constructed to close the open bottom of the vacuum-chamber with an air-tight joint while the mud is being raised, substantially in the manner and for the purpose described.

Witness my hand this 21st day of November, A. D. 1877.

AUGUSTINE CROSBY.

In presence of—

P. E. TESCHMACHER,  
W. J. CAMBRIDGE.