

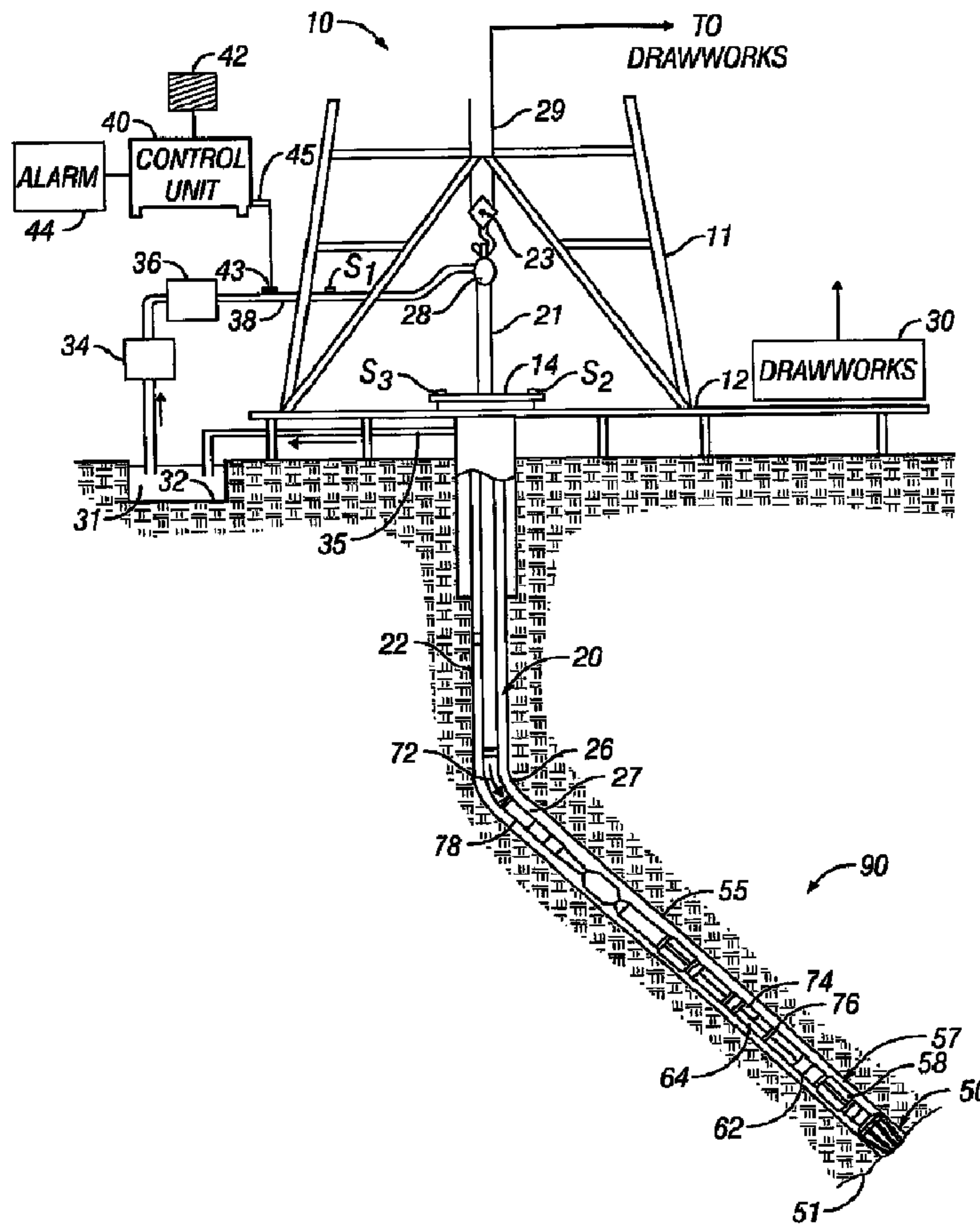

(86) Date de dépôt PCT/PCT Filing Date: 2007/08/13
 (87) Date publication PCT/PCT Publication Date: 2008/02/21
 (45) Date de délivrance/Issue Date: 2011/10/25
 (85) Entrée phase nationale/National Entry: 2009/02/26
 (86) N° demande PCT/PCT Application No.: US 2007/017929
 (87) N° publication PCT/PCT Publication No.: 2008/021329
 (30) Priorités/Priorities: 2006/08/11 (US60/837,054);
 2007/08/10 (US11/836,953)

(51) Cl.Int./Int.Cl. *E21B 47/06* (2006.01),
E21B 47/09 (2006.01), *G01L 1/12* (2006.01),
G01L 3/10 (2006.01)
 (72) Inventeur/Inventor:
 FREYER, CARSTEN, US
 (73) Propriétaire/Owner:
 BAKER HUGHES INCORPORATED, US
 (74) Agent: SIM & MCBURNEY

(54) Titre : APPAREIL ET PROCEDE D'ESTIMATION DES CHARGES S'EXERCANT SUR DES ELEMENTS DE FOND DE TROU ET DE LEUR MOUVEMENT
 (54) Title: APPARATUS AND METHODS FOR ESTIMATING LOADS AND MOVEMENTS OF MEMBERS DOWNHOLE



(57) Abrégé/Abstract:

This disclosure, in one aspect, provides an apparatus for use in a wellbore that includes a member having an encoded magnetic field and a sensor proximate the encoded magnetic field that measures a change in the magnetic field due to a change in the load

(57) **Abrégé(suite)/Abstract(continued):**

on the member. In another aspect, a method for measuring loads on a downhole tool is provided that comprises inducing an encoded magnetic field along a section of a member of the tool and detecting a change in the magnetic field due to a load on the member when the tool is in the wellbore.

(12) INTERNATIONAL APPLICATION PUBLISHED UNDER THE PATENT COOPERATION TREATY (PCT)

(19) World Intellectual Property Organization
International Bureau(43) International Publication Date
21 February 2008 (21.02.2008)

PCT

(10) International Publication Number
WO 2008/021329 A1

(51) International Patent Classification:

E21B 47/06 (2006.01) *G01L 1/12* (2006.01)
E21B 47/09 (2006.01) *G01L 3/10* (2006.01)

(21) International Application Number:

PCT/US2007/017929

(22) International Filing Date: 13 August 2007 (13.08.2007)

(25) Filing Language: English

(26) Publication Language: English

(30) Priority Data:

60/837,054 11 August 2006 (11.08.2006) US
 11/836,953 10 August 2007 (10.08.2007) US

(71) Applicant (for all designated States except US): **BAKER HUGHES INCORPORATED** [US/US]; P.O. Box 4740, Houston, TX 77027 (US).

(72) Inventor; and

(75) Inventor/Applicant (for US only): **FREYER, Carsten** [US/US]; 3628 Whispering Brook Drive, Kingwood, TX 77345 (US).(74) Agents: **RIDDLE, J., Albert et al.**; Baker Hughes Incorporated, P.O. Box 4740, Houston, TX 77027 (US).

(81) Designated States (unless otherwise indicated, for every kind of national protection available): AE, AG, AL, AM, AT, AU, AZ, BA, BB, BG, BH, BR, BW, BY, BZ, CA, CH, CN, CO, CR, CU, CZ, DE, DK, DM, DO, DZ, EC, EE, EG, ES, FI, GB, GD, GE, GH, GM, GT, HN, HR, HU, ID, IL, IN, IS, JP, KE, KG, KM, KN, KP, KR, KZ, LA, LC, LK, LR, LS, LT, LU, LY, MA, MD, ME, MG, MK, MN, MW, MX, MY, MZ, NA, NG, NI, NO, NZ, OM, PG, PH, PL, PT, RO, RS, RU, SC, SD, SE, SG, SK, SL, SM, SV, SY, TJ, TM, TN, TR, TT, TZ, UA, UG, US, UZ, VC, VN, ZA, ZM, ZW.

(84) Designated States (unless otherwise indicated, for every kind of regional protection available): ARIPO (BW, GH, GM, KE, LS, MW, MZ, NA, SD, SL, SZ, TZ, UG, ZM, ZW), Eurasian (AM, AZ, BY, KG, KZ, MD, RU, TJ, TM), European (AT, BE, BG, CH, CY, CZ, DE, DK, EE, ES, FI, FR, GB, GR, HU, IE, IS, IT, LT, LU, LV, MC, MT, NL, PL, PT, RO, SE, SI, SK, TR), OAPI (BF, BJ, CF, CG, CI, CM, GA, GN, GQ, GW, ML, MR, NE, SN, TD, TG).

[Continued on next page]

(54) Title: APPARATUS AND METHODS FOR ESTIMATING LOADS AND MOVEMENT OF MEMBERS DOWNHOLE

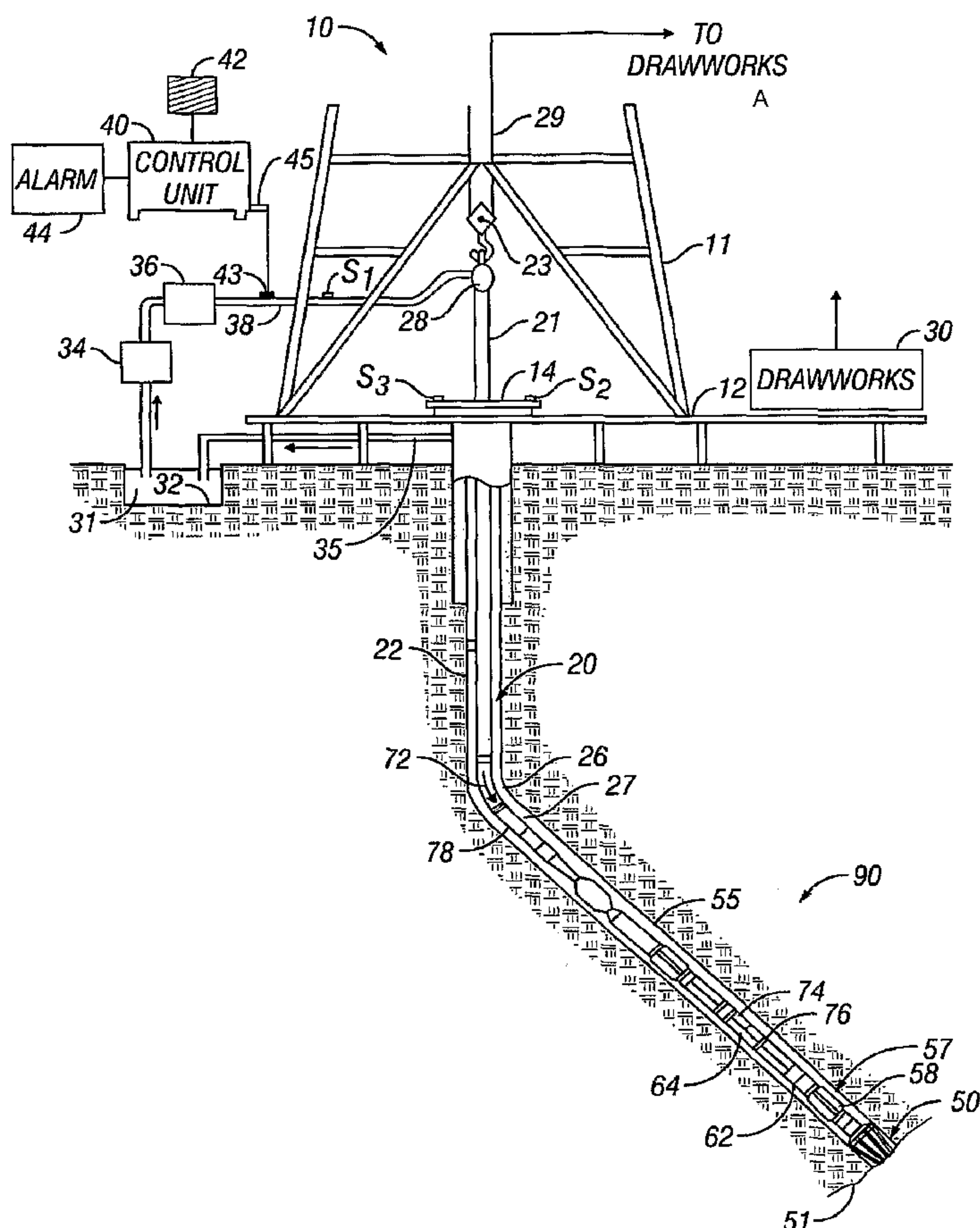

(57) Abstract: This disclosure, in one aspect, provides an apparatus for use in a wellbore that includes a member having an encoded magnetic field and a sensor proximate the encoded magnetic field that measures a change in the magnetic field due to a change in the load on the member. In another aspect, a method for measuring loads on a downhole tool is provided that comprises inducing an encoded magnetic field along a section of a member of the tool and detecting a change in the magnetic field due to a load on the member when the tool is in the wellbore.

WO 2008/021329 A1

WO 2008/021329 A1



Published:

- *with international search report*
- *before the expiration of the time limit for amending the claims and to be republished in the event of receipt of amendments*

TITLE: **APPARATUS AND METHODS FOR ESTIMATING
LOADS AND MOVEMENTS OF MEMEBRS
DOWNHOLE**

INVENTOR: **CARSTEN FREYER**

FIELD OF THE DISCLOSURE

[0001] This disclosure generally relates to apparatus and methods relating to wellbore operations, including determining loads on and movements of portions of tools.

BACKGROUND INFORMATION

[0002] To obtain hydrocarbons such as oil and gas, wells (also referred to as "wellbores" or "boreholes") are drilled by rotating a drill bit attached at a drill string end. A large number of the current drilling activity involves directional drilling, i.e., drilling deviated and horizontal boreholes, to obtain increased hydrocarbon production from subsurface formations. Such wellbores are often drilled along complex well paths. The systems used to drill such wellbores generally employ a drill string that has a drilling assembly (also referred to as a "bottomhole assembly" (BHA)) and a drill bit at an end thereof. The drill bit is rotated by rotating the drill string from the surface and/or by rotating the drill bit by a drilling motor (also referred to as the "mud motor") disposed in the drilling assembly. A drilling fluid (commonly known as the "mud" or "drilling mud") is pumped into a tubing of the drill string to rotate the drilling motor and the tubing is rotated by a prime mover at the surface, such as a motor. The drill bit is typically coupled to a bearing assembly having a drive shaft which in turn rotates the drill bit attached thereto. Radial and axial bearings in the bearing assembly provide support to the radial and axial forces of the drill bit.

[0003] A number of devices and sensors carried by the BHA measure various parameters or characteristics associated with the drill string. Such devices typically include sensors for measuring pressure, temperature, azimuth, inclination, vibration,

etc. The BHA also includes a variety of other devices or sensors, such as resistivity, acoustic, nuclear, nuclear magnetic resonance sensors, etc., which devices are commonly referred to a "measurement-while-drilling" ("MWD") or logging-while-drilling ("LWD") tools or sensors. MWD sensors are used to determine properties of the earth formation and the extent of the hydrocarbons contained in the formation. These devices and sensors contain complex and sensitive sensors and electronic components, which may remain disposed in the wellbore for several hours to days.

[0004] The BHA, during drilling of a wellbore, is subjected to varying load conditions, which may be due to bending moments exerted on various elements of the BHA by side forces acting on the BHA, vibration, weight on bit, etc. These forces can be caused by gravity, drilling dynamic effects and/or by contact between the wellbore wall and the BHA. The bending moments can cause deviations from the desired wellbore path. It is therefore desirable to measure loads on one or more components of the BHA and the movement or displacement of certain elements of the BHA with respect to fixed points or relative to other members so that actions may be taken to maintain the BHA within certain operating limits during drilling of the wellbore.

[0005] The disclosure herein provides apparatus and method for estimating loads and other parameters of interest relating to a wellbore operation.

SUMMARY

[0006] In one aspect, an apparatus for estimating a property of a tool downhole is disclosed that includes a member having a magnetic coded field section and at least one sensor that detects a change in the magnetic field downhole, such as due to a load or motion associated with the member. In one aspect, the sensor may include at least one coil proximate the coded magnetic field. In one embodiment, the member may be a rotating member and the sensor may be located in a non-rotating or substantially non-rotating member.

[0007] The apparatus, in one aspect, may include a circuitry that conditions the sensor signals. The sensor signals may be processed in part or whole by a downhole processor to determine the property of interest, such as a on the tool or movement of one component relative to another component or a fixed point. The load may be due to torque, axial movement, such as caused by compression, tension or bending. The processed signals may be sent to a surface controller for further processing either while drilling the wellbore or after retrieval of the drill string to the surface. A computer-readable storage medium, such as a solid-state memory device, associated with the processor may store data, information, computer programs, algorithms and models for use by the processor during drilling of the wellbore. The processor, in one aspect, communicates bi-directionally with the surface controller via a suitable telemetry scheme. In one aspect, the processor may activate a device downhole based at least in part on the measurements made by a sensor. In one aspect, the sensor measurements provide information about the bend of a member that may be used in a closed-loop manner to control the direction of drilling of a wellbore.

[0008] In another aspect, a magnetic sensor arrangement may provide measurements related to movement of a member of a downhole tool. In one aspect, a first member may include a magnetic coded section and a second member may carry one or more sensors that detect changes in the magnetic field of the coded magnetic field section due to movement of one or both members. The movement may be linear or angular. In one aspect, a section of a surface of a piston that moves a force application member outward (radially) may be magnetically coded and a stationary member proximate the piston surface may be configured to carry a sensor. Multiple pistons and associated force application members may be used to determine the

internal diameter or the dimensions of the wellbore from the movement measurements made by the sensors. In another aspect, a rotating member may be coded with the magnetic field and the sensors may be carried by the non-rotating member, wherein the sensors detect changes in the magnetic field when one member rotates with respect to the other member. The change in the magnetic fields provides the angular movement of one member with respect to the other member. The angular movement may also be used to determine the rotational speed of one of the members.

[0009] In another aspect, a method for estimating a parameter of interest downhole, including load on and/or movement of a member of a tool is disclosed. The method, in one aspect, including encoding a magnetic field due to a load on the member downhole. In one aspect, the method includes providing a signal that corresponds to the detected change in the magnetic field and processing the signal to estimate a parameter of interest, which may be torque, axial movement, bend or weight on bit of member with respect to a second member is disclosed. The method includes magnetically coding a section of the first member and placing at least one sensor on the second member proximate the magnetic coding, and detecting a change in the magnetic field when one or both members move relative to each other. The movement may be angular or axial. The method further may include providing a signal corresponding to the detected change and processing the signal to estimate the movement of a member. The method further may comprise transmitting information to the surface and/or storing the information at a downhole memory. In another aspect, the method may include controlling an operation of a device downhole at least in part in response to the processed signals. In another aspect, the method may include using information from an additional sensor to control the operation of the device. The additional sensor may include a directional sensor, resistivity sensor, an accelerometer, a gamma ray sensor, an NMR sensor, an acoustic sensor, a pressure sensor, a temperature sensor and/or another suitable sensor. The terms estimate, determine and calculate are used herein as synonyms.

[0009a] In another aspect there is provided a method of estimating a property of interest relating to an operation in a wellbore, comprising:

conveying a tool in the wellbore that includes a member that has a coded magnetic field;

4a

detecting a change in the coded magnetic field when the tool is in the wellbore;

estimating the property of interest using the detected change in the coded magnetic field; and

recording the estimated property of interest on a suitable medium.

[0009b] In yet another aspect there is provided an apparatus for use in a wellbore, comprising:

a member having a coded magnetic field;

a sensor that detects a change in the coded magnetic field when the apparatus is in the wellbore and provides a signal representative of the detected change; and

a processor that processes the signals to estimate a parameter of interest.

[0009c] In yet another aspect there is provided a system for drilling a wellbore, comprising:

a drilling assembly that includes a member that has a coded magnetic field;

a sensor proximate the coded magnetic field that provides a measure of a change in the coded magnetic field due to a load on the member during drilling of the wellbore and provides a signal representative of the change in the coded magnetic field; and

a processor that determines the load on the member using signals from the sensor and causes the drilling assembly to perform an operation during the drilling of the wellbore based at least in part on the determined load.

[0009d] In still yet another aspect there is provided an apparatus comprising:

a member having a coded magnetic field; and

a sensor proximate the coded magnetic field section that measures a change in the coded magnetic field when one of the member and the sensor moves relative to the other.

[00010] The Examples of the more important features of a methods and apparatus for estimating loads downhole have been summarized rather broadly in order that the

detailed description thereof that follows may be better understood, and in order that the contributions to the art may be appreciated. There are, of course, additional features that will be described hereinafter and which will form the subject of the claims. The summary provided herein is not intended to limit the scope of the claims in any way.

BRIEF DESCRIPTION OF THE DRAWINGS

[00011] The disclosure herein is best understood from the following detailed description referring to the drawings, in which same elements are generally referred by same numerals and wherein:

Figure 1 shows a schematic diagram of a drilling system having a drill string containing a drilling assembly that includes measurement devices according to one embodiment of the disclosure;

Figure 2 shows a longitudinal cross-section of a portion of a drilling assembly having a non-rotating sleeve around a magnetically encoded rotating member that may be utilized as one embodiment for estimating a parameter of interest;

Figure 3 shows a longitudinal cross-section of a portion of a drilling assembly having a magnetically encoded member and an a housing disposed therein according to another embodiment that may be utilized for estimating a parameter of interest;

Figure 4 shows a longitudinal cross-section of a portion of a drilling assembly having a magnetically encoded section and a housing around the magnetically encoded section according to another embodiment that may be utilized for estimating a parameter of interest;

Figure 5A shows a sensor for estimating or determining movement of a member according to one embodiment of the disclosure;

Figure 5B shows a sensor for estimating or determining movement of a rotating member according to another embodiment of the disclosure;

Figure 6 shows a block diagram of a system for estimating or determining loads on a member downhole and communicating information relating thereto to a surface controller according to one embodiment of the disclosure;

Figure 7 shows a sensor arrangement for estimating or determining torque on a member downhole according to one embodiment of the disclosure;

Figure 8 shows a sensor arrangement for estimating or determining bending on a member downhole according to one embodiment of the disclosure; and

Figure 9 shows a sensor arrangement for estimating or determining bending on a member downhole according to another embodiment of the disclosure.

DETAILED DESCRIPTION

[00012] FIG. 1 shows a schematic diagram of a drilling system 10 for estimating a property of interest of a tool downhole. The system includes a drill string 20 having a drilling assembly or BHA 90 conveyed in a borehole 26 for drilling a wellbore 20 in an earth formations 55. The drilling system 10 includes a conventional derrick 11 erected on a floor 12 that supports a rotary table 14 that is rotated by a prime mover, such as an electric motor (not shown), at a desired rotational speed. The drill string 20 includes a drill pipe 22 extending downward from the rotary table 14 into the borehole 26. A drill bit 50, attached to the end of the BHA 90, disintegrates the geological formations when it is rotated to drill the borehole 26. The drill string 20 is coupled to a drawworks 30 via a Kelly joint 21, swivel 28 and line 29 through a pulley 23. During the drilling of the wellbore, draw works 30 controls the weight on bit, which affects the rate of penetration.

[00013] During drilling operations, a suitable drilling fluid or mud 31 from a source or mud pit 32 is circulated under pressure through the drill string 20 by a mud pump 34. The drilling fluid 31 passes from the mud pump 34 into the drill string 20 via a desurger 36, fluid line 38 and the Kelly joint 21. The drilling fluid 31 is discharged at the borehole bottom 51 through an opening in the drill bit 50. The drilling fluid 31 circulates uphole through the annular space 27 between the drill string 20 and the borehole 26 and returns to the mud pit 32 via a return line 35. A sensor S_1 in the line 38 provides information about the fluid flow rate. A surface torque sensor S_2 and a sensor S_3 associated with the drill string 20 respectively provide information about the torque and the rotational speed of the drill string. Additionally, one or more sensors (not shown) associated with line 29 are used to provide the hook load of the drill string 20 and information about other desired parameters relating to the drilling of the wellbore 26.

[00014] In some applications, the drill bit 50 is rotated by only rotating the drill pipe 22. However, in many other applications, a downhole motor 55 (mud motor) disposed in the drilling assembly 90 is used to rotate the drill bit 50 and/or to superimpose or supplement the rotational power. In either case, the rate of penetration (ROP) of the drill bit 50 into the borehole 26 for a given formation and a drilling assembly largely depends upon the weight on bit and the drill bit rotational speed.

[00015] In one aspect of the system of **FIG. 1**, the mud motor **55** is coupled to the drill bit **50** via a drive shaft (not shown) disposed in a bearing assembly **57**. The mud motor **55** rotates the drill bit **50** when the drilling fluid **31** passes through the mud motor **55** under pressure. The bearing assembly **57** supports the radial and axial forces of the drill bit **50**, the downthrust of the drill motor and the reactive upward loading from the applied weight on bit. A stabilizer **58** coupled to the bearing assembly **57** acts as a centralizer for the lowermost portion of the mud motor assembly.

[00016] A surface control unit **40** receives signals from the downhole sensors and devices via a sensor **43** placed in the fluid line **38** and signals from sensors **S₁**, **S₂**, **S₃**, hook load sensor and any other sensors used in the system and processes such signals according to programmed instructions provided to the surface control unit **40**. The surface control unit **40** displays desired drilling parameters and other information on a display/monitor **42** that is utilized by an operator to control the drilling operations. The surface control unit **40** contains a computer, memory for storing data, recorder for recording data and other peripherals. The surface control unit **40** also includes a simulation model and processes data according to programmed instructions and responds to user commands entered through a suitable device, such as a keyboard. The control unit **40** is adapted to activate alarms **44** when certain unsafe or undesirable operating conditions occur. The use of the simulation model is described in detail later.

[00017] Referring back to **FIG. 1**, BHA **90** may also contain sensors and devices in addition to the above-described sensors. Such devices may include a resistivity device **64** for measuring the formation resistivity near and/or in front of the drill bit, a gamma ray device for measuring the formation gamma ray intensity and devices for determining the inclination and azimuth of the drill string. The resistivity device **64** may be coupled above the lower kick-off subassembly **62** that provides signals from which resistivity of the formation near or in front of the drill bit **50** is determined. An inclinometer **74** and gamma ray device **76** are suitably placed along the resistivity measuring device **64** for respectively determining the inclination of the portion of the drill string near the drill bit **50** and the formation gamma ray intensity. In addition, an azimuth device (not shown), such as a magnetometer or a gyroscopic device, may be utilized to determine the drill string azimuth. Such devices are known in the art and

therefore are not described in detail herein. In the above-described configuration, the mud motor 55 transfers power to the drill bit 50 via a hollow shaft that also enables the drilling fluid to pass from the mud motor 55 to the drill bit 50. In an alternate embodiment of the drill string 20, the mud motor 55 may be coupled below a resistivity measuring device 64 or at any other suitable place.

[00018] Still referring to FIG. 1, other LWD devices, such as devices for measuring formation porosity, permeability and density, may be placed above the mud motor 64 in the housing 78 for providing information useful for evaluating the subsurface formations along borehole 26. For example, gamma rays emitted from a source enter the formation where they interact with the formation and attenuate. The attenuation of the gamma rays is measured by a suitable detector from which density of the formation is determined.

[00019] The above-noted devices transmit data to a downhole telemetry system 72, which in turn transmits the received data uphole to the surface control unit 40. The downhole telemetry system 72 also receives signals and data from the uphole control unit 40 and transmits such received signals and data to the appropriate downhole devices. The system 10, in aspect may utilize a mud pulse telemetry technique to communicate data from downhole sensors and devices during drilling operations. A transducer 43 placed in the mud supply line 38 detects the mud pulses responsive to the data transmitted by the downhole telemetry 72. Transducer 43 generates electrical signals in response to the mud pressure variations and transmits such signals via a conductor 45 to the surface control unit 40. In other aspects, other telemetry techniques, such as electromagnetic telemetry, acoustic telemetry or another suitable telemetry technique may also be utilized for the purposes of this invention.

[00020] The drilling system described thus far relates to those drilling systems that utilize a drill pipe to conveying the drilling assembly 90 into the borehole 26, wherein the weight on bit is controlled from the surface, typically by controlling the operation of the drawworks. However, a large number of the current drilling systems, especially for drilling highly deviated and horizontal wellbores, utilize coiled tubing for conveying the drilling assembly downhole. In such an application a thruster is sometimes deployed in the drill string to provide the desired force on the drill bit. For the purpose of this invention, the term weight on bit is used to denote the force

applied to the drill bit during drilling operation, whether applied by adjusting the weight of the drill string or by thrusters or by any other method. Also, when coiled-tubing is utilized, the tubing is not rotated by a rotary table but instead it is injected into the wellbore by a suitable injector while the downhole motor, such as mud motor 55, rotates the drill bit 50. Also, for offshore drilling, an offshore rig or a vessel is used to support the drilling equipment, including the drill string.

[00021] In one aspect, the BHA 90 includes a sensor circuitry, programs and algorithms for providing information about various types of loads on the BHA 90 or a portion thereof. Such sensors, as explained later in reference to FIG'S. 2-9, in one aspect, are magnetically coded contactless sensors configured to provide measurements for loads on one or more sections or members of the BHI. The load may be an axial load (such as a compression load or a tensile load), a torsional load or a bending load. Such sensors may be disposed at any suitable locations in the BHA 90, including a steering unit 58. The load measurements, in one aspect, may be utilized to estimate or determine one or more parameters of interest, such as weigh on bit (WOB), bending or bending moment, or torque. The load measurements may be used directly or indirectly to operate a device in the BHA, such as the steering unit 58, for example to drill the wellbore along a particular path, to maintain the drilling direction along a selected path, or to determine wear on certain members of the BHA, such as a bearing assemblies, etc.

[00022] In another aspect, the BHA 90 may include magnetic coded sensors that may be configured to measure displacement (movement) of one member relative to another member or a fixed point. The displacement may be a linear or axial movement, rotational movement or a bending movement. The displacement measurements may be used to determine and adjust a force applied by a rib or force application member of a steering mechanism to drill the well along a particular path or to estimate a parameter relating to the BHA, such as rotational speed of a member, angular movement of a member, etc. The term load or loads used herein includes, but is not limited to, bending loads, torque loads, and axial loads (compressional and tensile loads). The determination of such loads, as noted above, allows for the determination of drilling parameters such as BHA side forces, drill bit side forces, weight on bit (WOB), and drilling motor and drill bit conditions and efficiencies. The

load and/or displacement measurement signals may be processed downhole and/or at the surface to determine the relative value or severity of parameters related to such measurements. The downhole information may be sent to the surface control unit 40 via a suitable telemetry system 72. The terms estimate, determine and calculate are used as synonyms.

[00023] FIG. 2 shows a cross section of a portion 58 of the drilling assembly 90 that includes a rotating member 101 that rotates when the drill string 22 (see FIG. 1) is rotated. In the configuration of FIG. 1, member 101 transmits torque, bending, loading, axial loading and WOB through threaded connection 121 to drill bit 50. In one embodiment, member 101 is a tubular member having a reduced diameter section 120. A non-rotating or substantially non-rotating sleeve or housing 102 surrounds the reduced diameter section 120 and is rotationally disengaged from member 101 by virtue of bearings 106 installed in appropriate grooves in member 101 and housing 102. Gap 115 is maintained between reduced diameter section 120 and housing 102 by bearings 106. In one embodiment, gap 115 is unsealed and may be filled with the drilling fluid. In another aspect, gap 115 may be sealed and filled with a suitable fluid.

[00024] Reduced diameter section 120 has coded or encoded magnetic field 114 induced along more segments thereof such that loads of member 101 alter the orientation of magnetic flux lines of magnetic field 114. The magnetization of coded magnetic field section 120 may be done by using any suitable technique, including but not limited to encoding methods shown in U.S. Patent Nos. 6,904,814, 6,581,480 and U.S. Patent Application No. 2005/0193834A1. The coded magnetic field's depth, pattern and dimensions may be determined based on the particular application and the nature of the downhole environment.

[00025] Generally, the term "coded or encoded magnetic field" herein means a member that is magnetized for a particular purpose. Magnetic field 114 extends outward from section 120. Changes in magnetic field 114, caused by loading of member 101 are detected by one or more sensors placed proximate the magnetic encoded field. These measurements are related to the loading imposed on member 101. Different orientations of sensors 108 provide for determination of different

loading types, as discussed later in reference to **FIGS. 7-9**. Multiple sensors **108**, having different orientations, may be employed in the same assembly for determining different types of loads at the same time. Sensors **108**, in one embodiment, include inductor coils sized to detect the changes in the magnetic field caused by the loading on member **101**.

[00026] The controller **105** processes the signals for circuitry **107** to determine one or more parameters of interest for such signals. The sensor system that includes sensors **108** includes an electronic module or circuitry **107** that receives output signals from sensors **108** and provides the signals to a controller **105** that may process the received signals to provide information relating to one or more parameters of interest, such as weight on-bit, torque, azimuthal or axial displacement, bend, bending moment, RPM, etc. The controller **105** as described in more detail with respect to **FIG. 6** may include a processor, memory and related circuitry and programs or programmed instructions. The controller **105**, in one aspect, may transmit the information or data via a sensor arrangement to **113a** and **113b** that may include an inductive coupling or slip ring arrangement to transfer data and power between the rotating member and non-rotating member **101**. Thus, the sensor arrangement shown in **FIG. 1** is a dynamic arrangement wherein the magnetic coded section rotates with respect to a non-rotating sensor or detector. The location of the magnetic coded section and the sensors **108** may be reversed.

[00027] In another aspect, the controller **105** may operate or control a downhole device in response to the measurements made by the downhole magnetic sensor arrangement. For example, the controller may control a force application member to change drilling direction, such as shown in **FIG. 2**. **FIG. 2** shows a force application member or rib **103** that is pivotally attached to the member **102** and is adapted to move between a retracted position and an extended position (radially outward) as shown by the arc **110**. A hydraulic unit **119** that includes a motor and pump drives a piston arrangement **104** to cause the rib **103** to move from the retracted position (shown) to an extended position. The controller **105** controls the hydraulic unit **119** to cause the rib **103** to apply a desired force on the wellbore wall. The BHA typically may include three or more ribs **103** and they may be independently controlled by one or more controllers **105**. The system of **FIG. 2** may further include one or more

secondary sensors to provide measurements relating to drilling assembly parameters, such as direction of the BHA and/or formation parameter, such as resistivity, porosity, density, pressure, etc. The controller **105** may utilize one or more of the drilling and/or formation parameters to operate or control a downhole device in response to or based on the measurements of the magnetic sensor arrangement of the present disclosure. In one aspect, the above-described system provides a closed-loop drilling system that may be used to control the drilling direction of the wellbore **26** by controlling, e.g. the bend of the member **101** based on the measurements from the sensor arrangement (**108**, **114**).

[00028] Referring to **FIG. 2** and **FIGS. 7-9** various arrangements of magnetic sensors are shown for measuring different types of loads on member **101**. **FIG. 7** shows an arrangement suitable for measuring torque on member **101**. A pair of sensors **108** are aligned along an axis that is substantially parallel to the longitudinal z-axis of member **101**. In one embodiment, multiple pairs of sensors **108** may be located around member **101**. Sensor pairs are positioned to detect the flux lines in magnetic field **114**. Torque "T" on member **101** causes a related change in magnetic field **114** that is detected by sensors **108** and transmitted to controller **105**, as described above.

[00029] **FIG. 8** shows an arrangement of sensors **108** suitable for measuring bending in both the "x" and "y" axes on member **101**. As shown, in one embodiment, sensors **108** are located in an x-y plane that is substantially perpendicular to the longitudinal z-axis of member **101**. Sensors **108** are mounted in pairs B_x and B_y on opposite sides of member **101**, for measuring the corresponding bending about the X and Y axes. The B_x and B_y components may be suitably combined to determine the actual vector orientation of the bending of member **101**. Sensors **108** are substantially tangential to the outer surface of member **101**. Bending of member **101** causes a related change in the magnetic field **114** that is detected by sensors **108** and transmitted to controller **105**, as described above.

[00030] **FIG. 9** shows an arrangement suitable for measuring axial strain of member **101** relative to sensors **108**. The axial strain is indicative of load on member **101** and may be further related to WOB. Two sensors **108** are aligned, spaced apart, along an axis that is substantially parallel to the longitudinal axis Z of member **101**. Changes in

axial loading of member 101 causes a related change to magnetic field 114 that is detected by sensors 108 and the signal transmitted to controller 105, as described above.

[00031] As previously discussed, the arrangements of sensors in FIGS. 7-9 are shown separately for clarity. It is intended that the disclosure herein encompass any combination of sensor arrangements for measuring one or more of the loadings on member 101 or movement of one member relative to another member.

[00032] FIG. 3 shows another embodiment, in which both drill string sub 201 and sensor insert 202 are fixed to rotate together by key 207 which engages both sub 201 and insert 202. Any suitable method of fixing sub 201 to insert 202 may be used for purposes of this invention. An arrangement wherein the two members carrying the sensor arrangements are attached is referred to herein as the static arrangement. In this embodiment, inner surface 209 has an encoded magnetic field 206 induced on an axial length thereof, such that loads on sub 201 alter the orientation of magnetic flux lines of magnetic field 206. Changes in magnetic field 206 caused by loading of sub 201 are detected by sensors 205. Different orientations of sensors 205, similar to those discussed previously with respect to FIGS. 7-9, provide for determination of different loading types. Sensor insert 202 is separated by gap 210 from sub 201 over at least an axial length of magnetic field 206. Coil interface electronics 203 relate the detected changes in magnetic field 206 to loads on sub 201 due to the controller, such as controller 105 described above with respect to FIG. 2. The load data are transmitted over conductors (such as conductor 112 (FIG. 2) to telemetry system 72 in the BHA for transmission to surface controller 40.

[00033] In another embodiment, see FIG. 4, sensor module 302 rotates with member 301. Member 301 has a reduced diameter section 308 having an encoded magnetic field 307 induced on an axial length thereof, such that loads on member 301 alter the orientation of magnetic flux lines of magnetic field 307. Changes in magnetic field 307, caused by loading of member 301, are detected by sensors 304 and related to the loading imposed on member 301. Different orientations of sensors 304, similar to those discussed previously with respect to FIGS. 7-9, provide for determination of different loading types. Sensor module 302 is separated by gap 306 from member 301 over at least the axial length of magnetic field 307. Coil interface electronics 303

relate the detected changes in magnetic field 307 due to loads on member 301 to the downhole controller, such as shown controller 105 (FIG. 2). The load data are transmitted over conductors (such as 112, FIG. 2) to telemetry system 72 for transmission to surface controller 40. Sensor module 302 may be a clamshell arrangement surrounding member 301. Alternatively, multiple sensor modules 302 may be fixed in axially elongated pockets formed in the external surface of member 301. Also, alternatively, the magnetic coding 306 may be done on member 301 while the sensors 304 and related circuitry etc. may be placed on member 302.

[00034] FIG. 5A shows an exemplary arrangement for measuring movement of one member 401 with respect to another member 402 in a downhole tool. FIG. 5A shows three pistons 403a-c that are adapted to move independently between their respective retracted positions and extended positions. Each piston 403 causes its respective rib 103 to move accordingly. In one embodiment, the pistons 403a-403c may be instrumented or configured to determine the position of each arm relative to an unenergized position. By determining the position of arms 103a-103c, the diameter of the borehole maybe determined at any suitable borehole depth. Thus, the sensor arrangement may be used as a caliper for in-situ measurements of the internal dimensions of the borehole 26.

[00035] As shown in FIG. 5A, surface 410 of each piston member 403 is magnetized with an encoded magnetic field. When powered, the piston 403 moves radially outward. Sensors 404 detect the movement of piston 403. The movement of the pistons 403 relate to the position of the ribs 103 (see FIG. 2). The signals from sensors 404 may be processed by the controller 407 or sent uphole for processing. The controller 407, using the movement measurements of pistons 403 can determine the inside diameter of the borehole 26.

[00036] In another embodiment, the sensor arrangement similar to one shown in FIG. 5A may be used to determine relative movement between any two members.

[00037] In another aspect, the sensor arrangement according to one embodiment may be used to determine angular displacement of a member. FIG. 5B shows a member 502 that rotates relative to another member 504. The rotating member 502 may include a magnetically coded filed 506 and the other member 504 may include one or more sensors 508. The sensors 508 provide signals that correspond to the

movement of member 502 relative to the sensors 508. These measurements may be used to determine the angular displacement of member 502 relative to member 504 and to determine the rotational speed (RPM). A controller, similar to controller 105 described with respect to FIG. 2, may be used for processing sensor 508 signals. The position data are transmitted over conductors (e.g. conductors 112, FIG. 2) to telemetry system 72 for transmission to surface controller 40.

[00038] FIG. 6 shows a block diagram of a system for determining loads on a downhole assembly and/or movement of a member of a downhole assembly, communicating the load information to a surface controller and/or to perform a downhole operation. The system of FIG. 6 shows an optional circuitry 107 that may include amplifiers and other components to condition signals from sensors 608 responsive to changes in the magnetic field received by the sensors 608. A processor 605 of the controller 105 processes the conditioned or direct signals from the sensors 608 to determine the load on the member 602 or movement of the member 602 relative to the sensors 608. The controller includes a memory 642 (computer-readable media) for storing therein. The data from the processor programs 644 provides executable instructions to the processor 605, which when executed perform the methods described herein. The processor 605 also may receive information from one or more sensors 610, such as directional sensors, sensors that provide a drilling parameter or a parameter of the formation.

[00039] The processor 605 in one aspect transmits information to the surface controller via a downhole telemetry module 72. The processor also receives signals, including command and control signals from the surface controller 40 and in response thereto performs the desired functions, including controlling devices 604. The processor may control a device, such as a steering device to control the drilling direction, operate a valve or other activity device to control flow of fluid through a device downhole, etc. In any case, the process uses information obtained from the magnetic coded sensor arrangement (606, 608) at least in part, to perform the described functions.

[00040] Thus, an apparatus for measuring loads on a member downhole may include a magnetic field encoded section. A sensor detects a change in the magnetic field due to a load on the member. The sensor may include at least one coil proximate the

magnetic field encoded section. In one embodiment, the member may be a rotating member and the sensor may be located in or on non-rotating member. The rotating member may drive a drill bit for drilling a wellbore. In one embodiment, the apparatus may further include a controller having a processor and a memory that determines the load on the member from the detected change in the magnetic field. The load on the member may be: (i) torque; (ii) bending; (iii) weight on bit; and/or (iv) an axial movement.

[00041] A method for estimating a load on a member in a wellbore may include: encoding a magnetic field along a section of the member; and detecting a change in the magnetic field due to a load on the member downhole. The method and apparatus may be used to activate or operate a device downhole, such as a device to steer a drilling assembly to drill a wellbore along a desired path. In another aspect, angular movement of members may be determined by using one or more magnetic coded sensor arrangements. The angular movement may include a measurement of displacement or movement of one member relative to another member or relative to a fixed position, rotational speed of a member, etc.

[00042] While the foregoing disclosure is directed to the described embodiments of the invention, various modifications will be apparent to those skilled in the art. It is intended that all variations of the appended claims be embraced by the foregoing disclosure. The abstract is provided to meet certain filing requirements and is not intended to limit the scope of the claims in any manner.

What is claimed is:

1. A method of estimating a property of interest relating to an operation in a wellbore, comprising:
 - conveying a tool in the wellbore that includes a member that has a coded magnetic field;
 - detecting a change in the coded magnetic field when the tool is in the wellbore;
 - estimating the property of interest using the detected change in the coded magnetic field; and
 - recording the estimated property of interest on a suitable medium.
2. The method of claim 1, wherein the property of interest is load.
3. The method of claim 2 further comprising calculating using the load a parameter that is selected from a group consisting of: (i) torque; (ii) bend; (iii) weight on drill bit; (iv) axial movement; (v) radial movement; (vi) placement; and (vii) an inside dimension of the wellbore.
4. The method of any one of claims 1 to 3, wherein detecting a change in the coded magnetic field is done during drilling of the wellbore.
5. The method of any one of claims 1 to 4 further comprising processing signals representative of the change in the coded magnetic field by a processor that is placed at one of: within the tool; and at a surface location.
6. The method of claim 1, wherein the parameter of interest is torque and wherein the coded magnetic field comprises at least two spaced apart coded magnetic fields on opposite sides of the member.
7. The method of claim 1, wherein the parameter of interest is bending and wherein the coded magnetic field comprises at least two substantially orthogonal magnetic fields.

8. The method of claim 1, wherein detecting a change in the coded magnetic field comprises detecting displacement of the coded magnetic field relative to a sensor proximate the coded magnetic field and wherein the parameter of interest is movement of the member relative to a selected point in the tool.

9. The method of claim 8, wherein the coded magnetic field and sensor are arranged in a manner that is one of: (i) the coded magnetic field is on a member that moves and the sensor is at a position that is fixed relative to the member; and (ii) the coded magnetic field is on a member that is fixed and the sensor moves relative to the member.

10. An apparatus for use in a wellbore, comprising:
a member having a coded magnetic field;
a sensor that detects a change in the coded magnetic field when the apparatus is in the wellbore and provides a signal representative of the detected change;
and
a processor that processes the signals to estimate a parameter of interest.

11. The apparatus of claim 10, wherein the parameter of interest is selected from a group consisting of: (i) load; (ii) torque; (iii) movement or displacement; (iv) bending; and (v) weight on drill bit.

12. The apparatus of claim 10 or 11, wherein the sensor includes at least one coil proximate the coded magnetic field with a gap between the at least one coil and the coded magnetic field.

13. The apparatus of any one of claims 10 to 12, wherein the apparatus includes a drilling assembly and wherein the member rotates relative to the sensor during drilling of the wellbore by the drilling assembly.

14. The apparatus of any one of claims 10 to 13 further comprising a data storage device that has embedded therein programmed instructions accessible to the

processor and wherein the processor utilizes the programmed instructions to estimate the parameter of interest.

15. The apparatus of any one of claims 10 to 14 further comprising a telemetry unit that is configured to transmit data relating to the parameter of interest to the surface during an operation of the tool in the wellbore.

16. The apparatus of any one of claims 10 to 15, wherein the coded magnetic field is on a moving piston that moves a force application member and the sensor is placed across from the coded magnetic field.

17. The apparatus of any one of claims 10 to 16, wherein the processor is configured to cause the apparatus to perform an operation in the wellbore based at least in part on a measurement made by the sensor.

18. The apparatus of claim 17, wherein the operation is selected from a group consisting of: applying force to a wall of the wellbore during drilling of the wellbore using the apparatus to drill the wellbore along a desired trajectory; and altering rotation of a drill bit carried by the apparatus during drilling of the wellbore.

19. A system for drilling a wellbore, comprising:
a drilling assembly that includes a member that has a coded magnetic field;
a sensor proximate the coded magnetic field that provides a measure of a change in the coded magnetic field due to a load on the member during drilling of the wellbore and provides a signal representative of the change in the coded magnetic field;
and

a processor that determines the load on the member using signals from the sensor and causes the drilling assembly to perform an operation during the drilling of the wellbore based at least in part on the determined load.

20. The system of claim 19, wherein the processor further determines from the load at least one of: (i) torque; (ii) bend; and (iii) displacement of the member relative to the sensor.

21. The system of claim 19 or 20 further comprising:
a plurality of force application devices that independently apply force on the wellbore, wherein each force application device includes a movable piston that has a coded magnetic field and a sensor that provides a measure of movement of an associated piston.
22. The apparatus of claim 21, wherein the processor is further configured to adjust the force applied by each force application member based on the movement of its associated piston.
23. An apparatus comprising:
a member having a coded magnetic field; and
a sensor proximate the coded magnetic field section that measures a change in the coded magnetic field when one of the member and the sensor moves relative to the other.
24. The apparatus of claim 23, wherein the movement of one of the member and the sensor corresponds to one of: (i) a linear movement; (ii) an angular movement; and (iii) a movement along a non-linear path.
25. The apparatus of claim 23 further comprising a processor that estimates a rotational speed of the sensor or member using the measured change in the coded magnetic field.

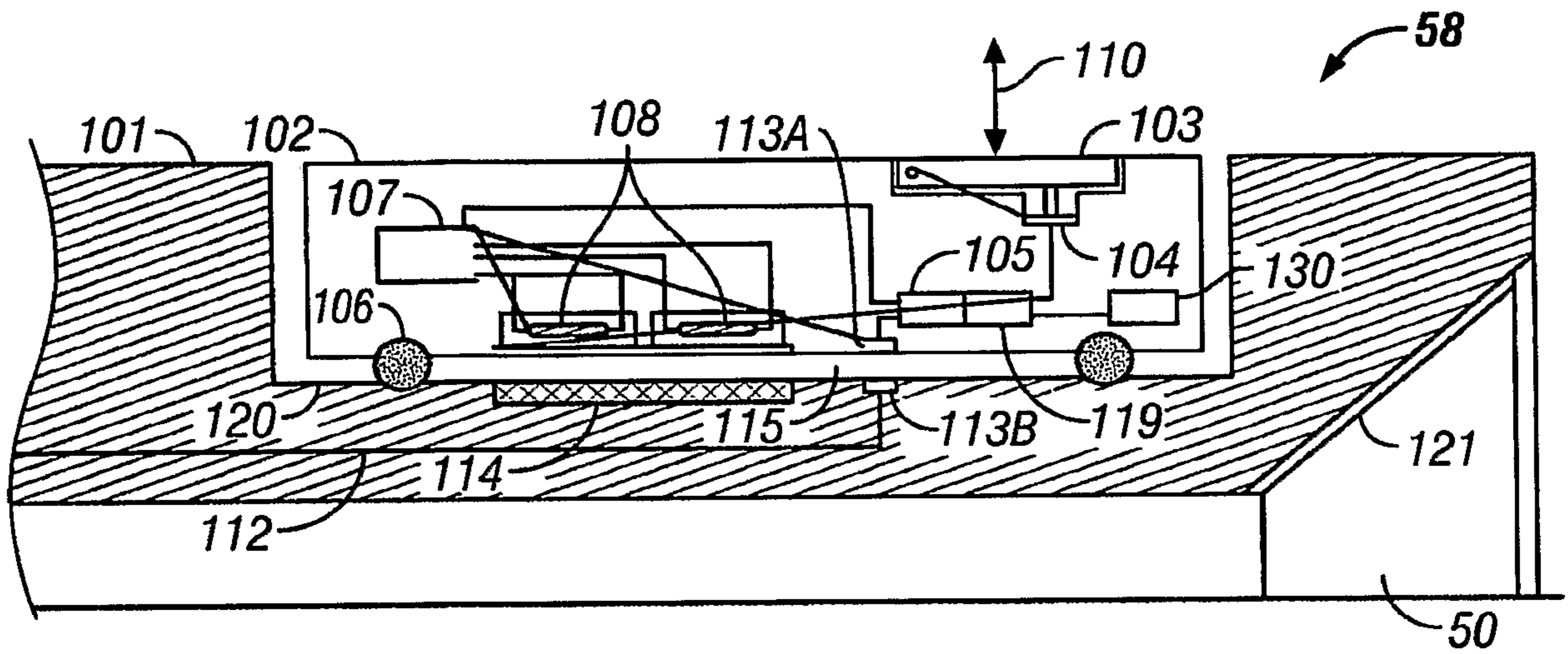

FIG. 2

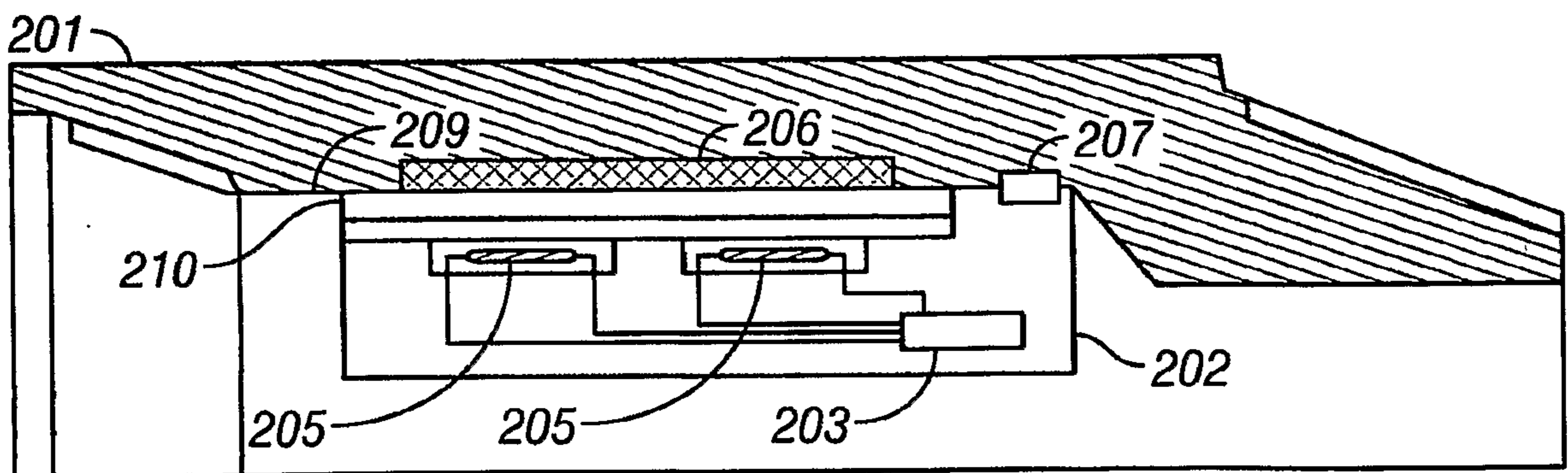

FIG. 3

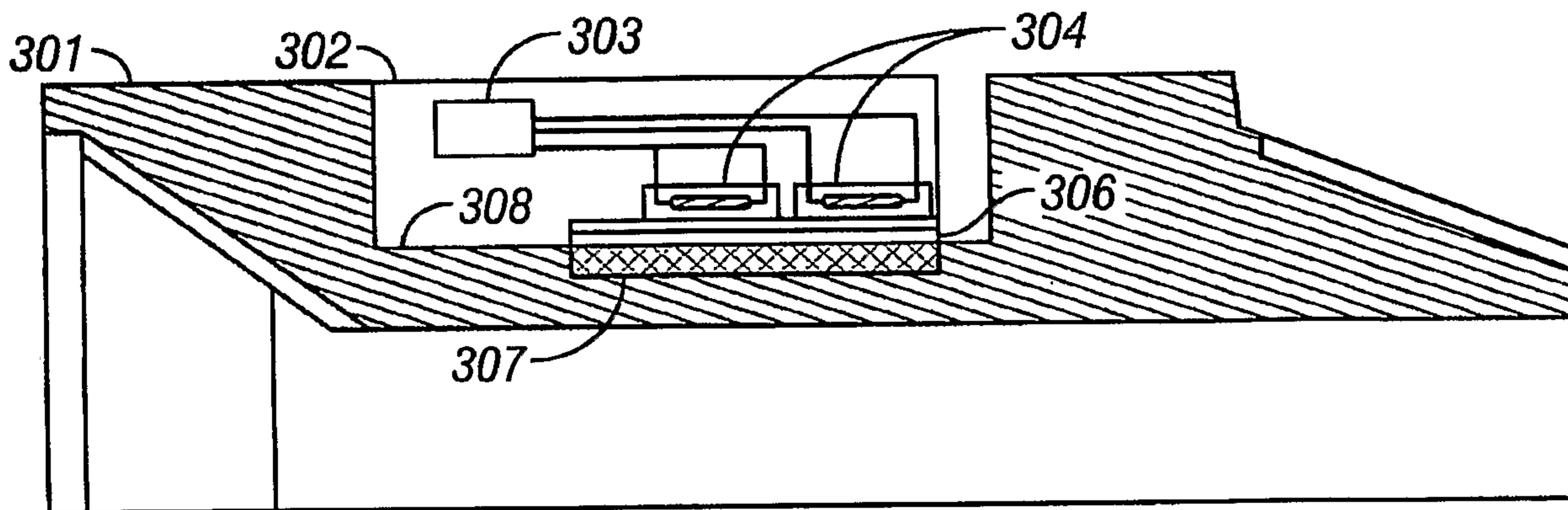

FIG. 4

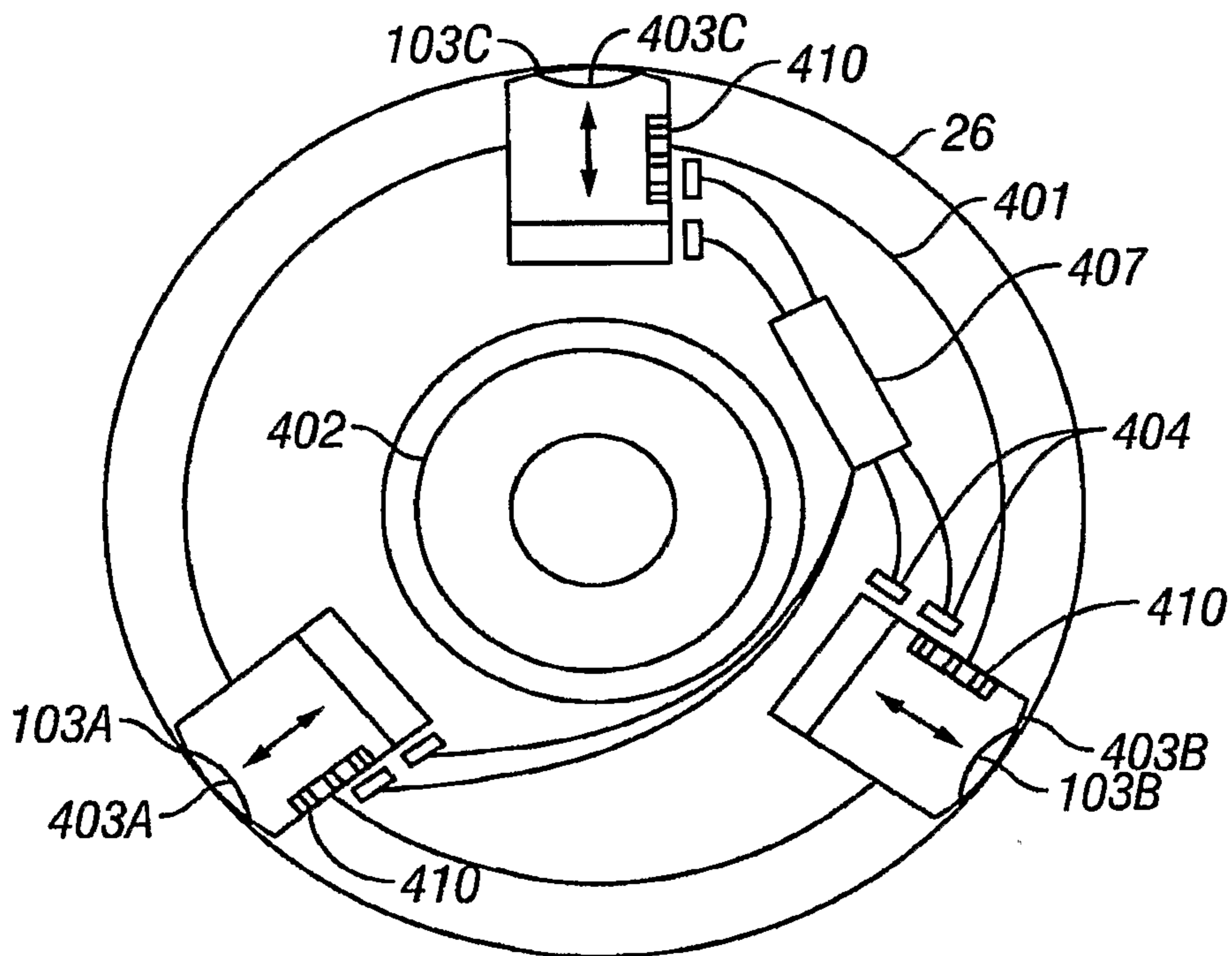

FIG. 5A

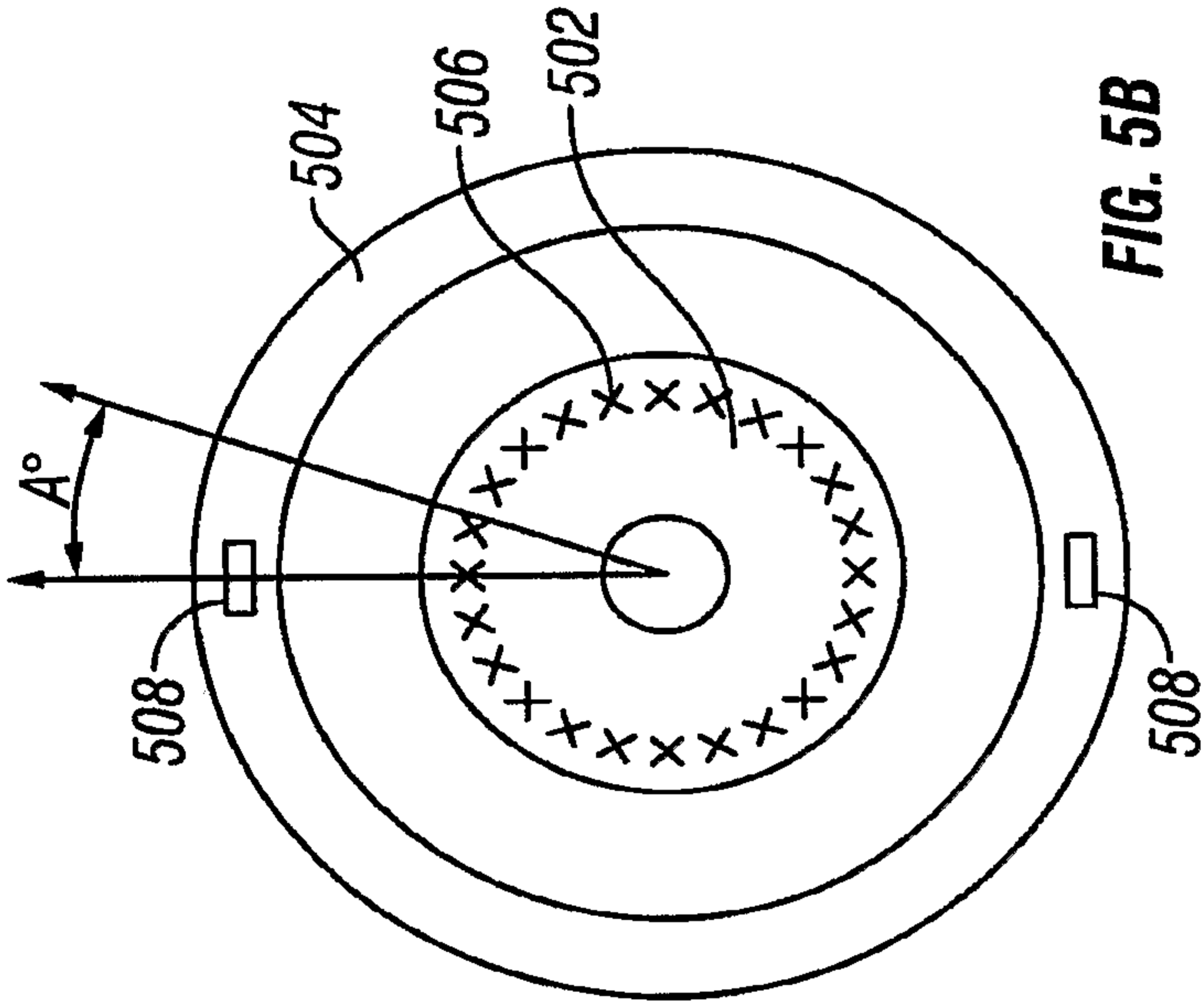

FIG. 5B

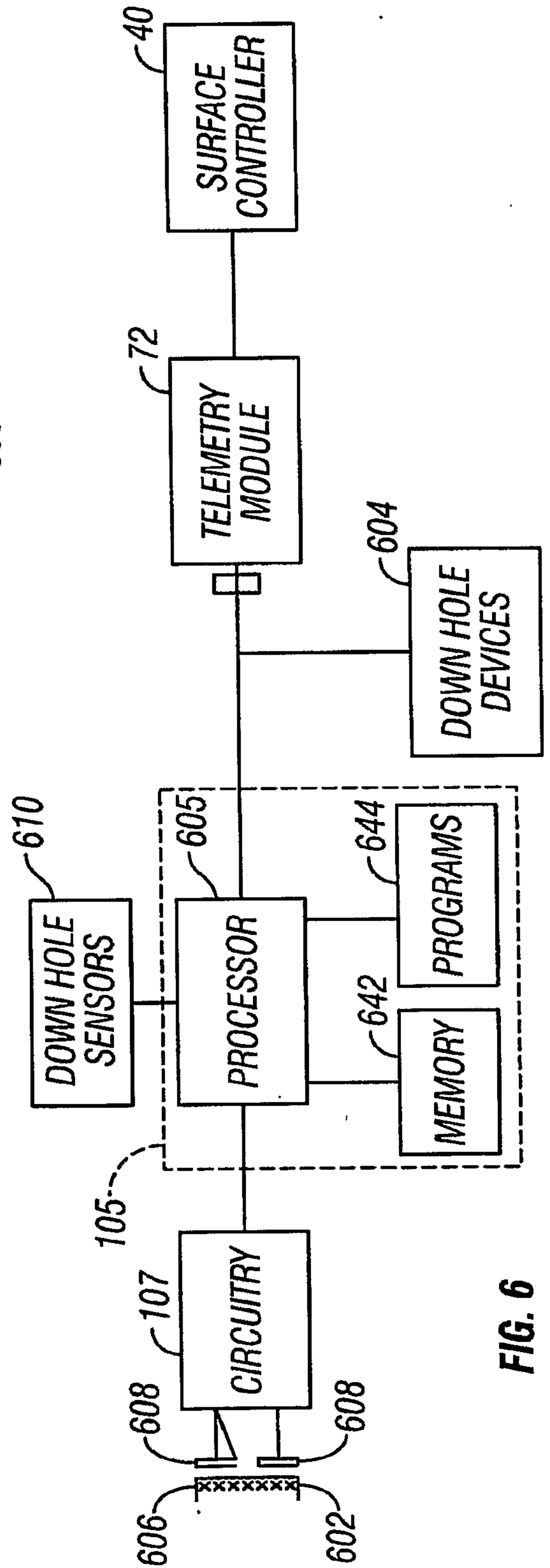
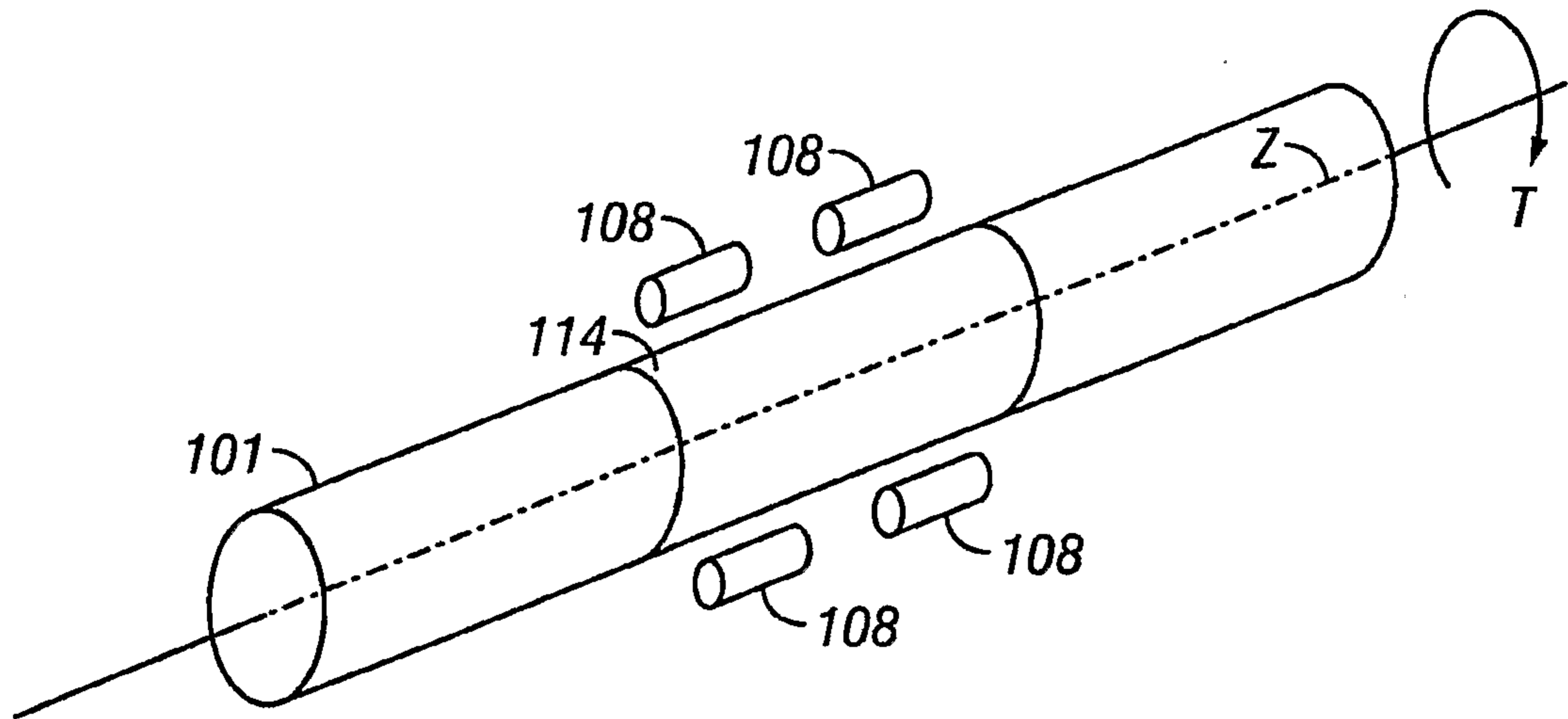
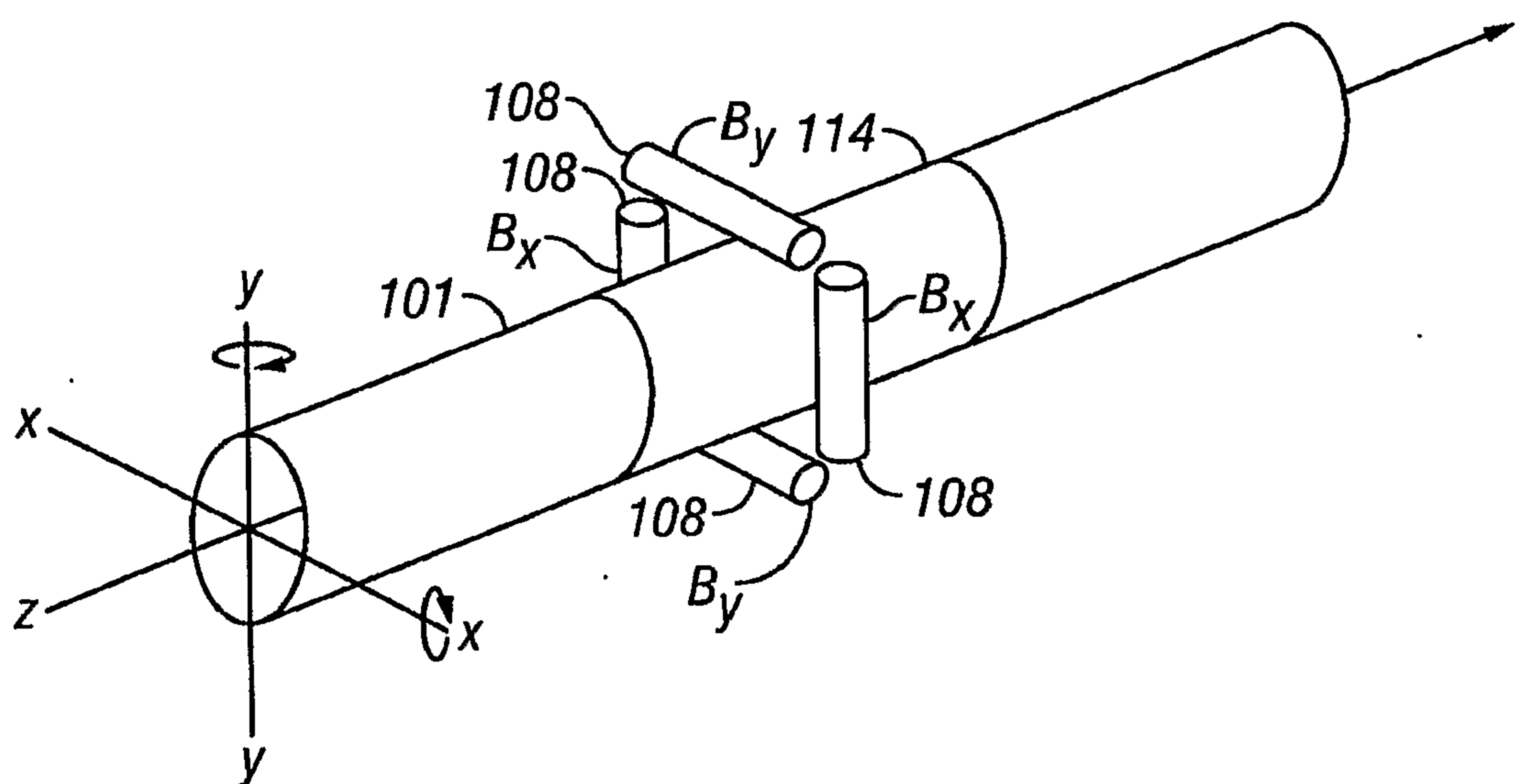

FIG. 6

**FIG. 7****FIG. 8**

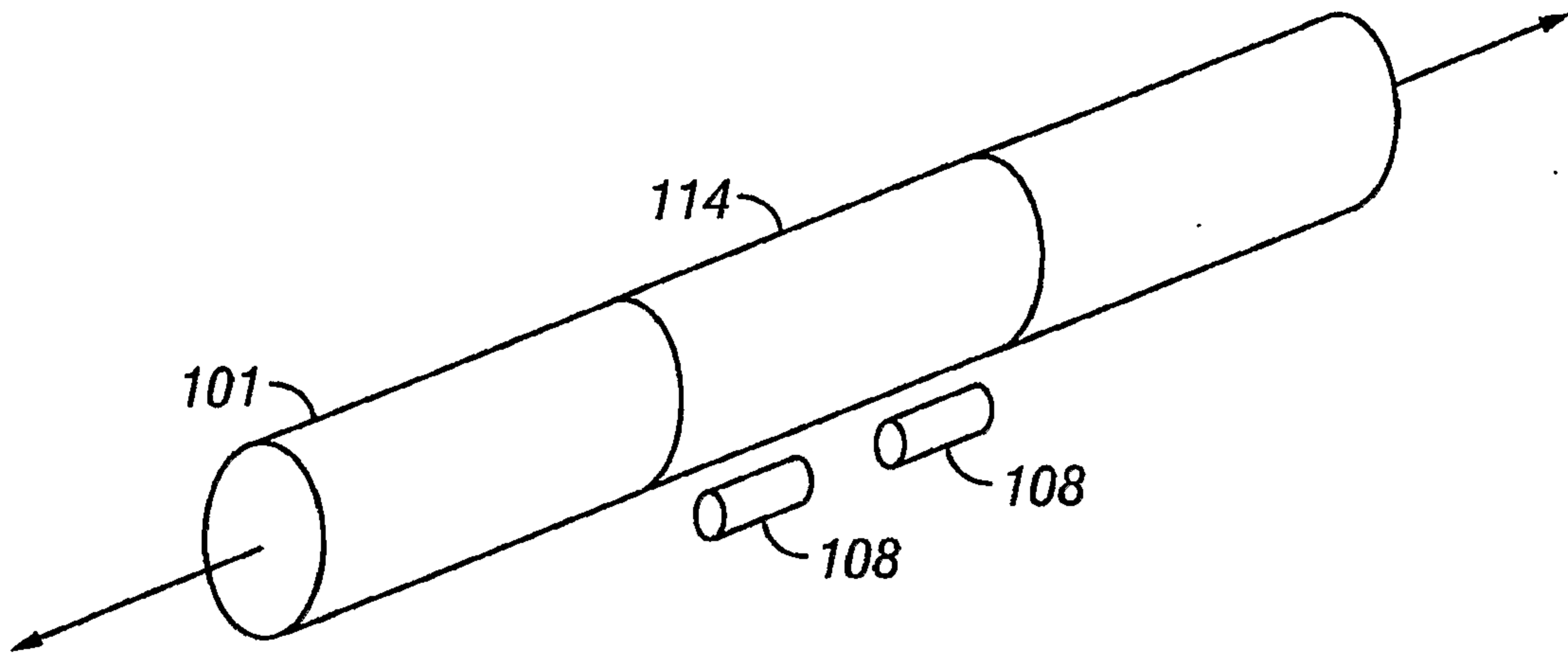

FIG. 9

