



- (51) **International Patent Classification:**  
*B01F 7/22* (2006.01)      *B01F 15/00* (2006.01)  
*B01F 3/12* (2006.01)
- (21) **International Application Number:**  
PCT/US2016/022733
- (22) **International Filing Date:**  
17 March 2016 (17.03.2016)
- (25) **Filing Language:** English
- (26) **Publication Language:** English
- (30) **Priority Data:**  
14/668,032      25 March 2015 (25.03.2015)      US
- (71) **Applicant (for US only):** **SCHLUMBERGER TECHNOLOGY CORPORATION** [US/US]; 300 Schlumberger Drive, Sugar Land, Texas 77478 (US).
- (71) **Applicant (for CA only):** **SCHLUMBERGER CANADA LIMITED** [CA/CA]; 125 - 9 Avenue SE, Calgary, Alberta T2G 0P6 (CA).
- (71) **Applicant (for FR only):** **SERVICES PETROLIERS SCHLUMBERGER** [FR/FR]; 42 rue Saint Dominique, 75007 Paris (FR).
- (71) **Applicant (for all designated States except CA, FR, US):** **SCHLUMBERGER TECHNOLOGY B.V.** [NL/NL]; Parkstraat 83-89m, NL-2514 JG The Hague (NL).
- (72) **Inventor:** **CHONG, Jonathan Wun Shiung**; 14231 FM 1464 Rd., Apt. 18202, Sugar Land, Texas 77478 (US).
- (74) **Agents:** **FLYNN, Michael L.** et al.; 10001 Richmond Avenue, IP Administration Center of Excellence, Room 4720, Houston, Texas 77042 (US).
- (81) **Designated States (unless otherwise indicated, for every kind of national protection available):** AE, AG, AL, AM, AO, AT, AU, AZ, BA, BB, BG, BH, BN, BR, BW, BY, BZ, CA, CH, CL, CN, CO, CR, CU, CZ, DE, DK, DM, DO, DZ, EC, EE, EG, ES, FI, GB, GD, GE, GH, GM, GT, HN, HR, HU, ID, IL, IN, IR, IS, JP, KE, KG, KN, KP, KR, KZ, LA, LC, LK, LR, LS, LU, LY, MA, MD, ME, MG, MK, MN, MW, MX, MY, MZ, NA, NG, NI, NO, NZ, OM, PA, PE, PG, PH, PL, PT, QA, RO, RS, RU, RW, SA, SC, SD, SE, SG, SK, SL, SM, ST, SV, SY, TH, TJ, TM, TN, TR, TT, TZ, UA, UG, US, UZ, VC, VN, ZA, ZM, ZW.
- (84) **Designated States (unless otherwise indicated, for every kind of regional protection available):** ARIPO (BW, GH, GM, KE, LR, LS, MW, MZ, NA, RW, SD, SL, ST, SZ, TZ, UG, ZM, ZW), Eurasian (AM, AZ, BY, KG, KZ, RU, TJ, TM), European (AL, AT, BE, BG, CH, CY, CZ, DE, DK, EE, ES, FI, FR, GB, GR, HR, HU, IE, IS, IT, LT, LU,

[Continued on next page]

(54) **Title:** BLENDER FOR MIXING AND PUMPING SOLIDS AND FLUIDS AND METHOD OF USE THEREOF

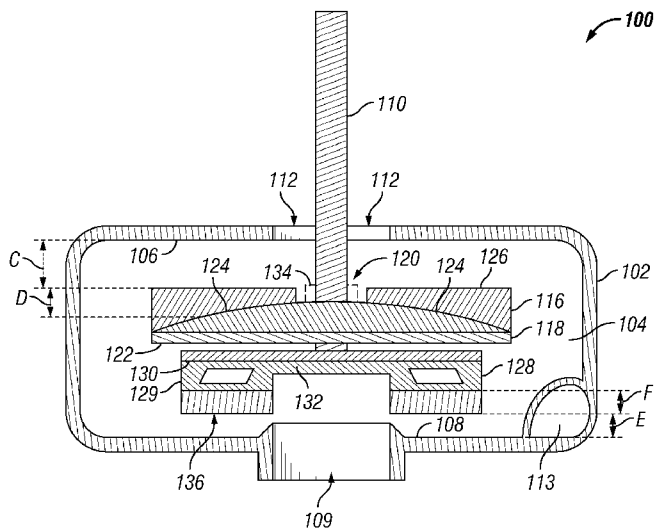


FIG. 1

(57) **Abstract:** An apparatus and method are disclosed for mixing and pumping solids and fluids and includes use of a blender including: a casing defining a cavity; a drive shaft extending through a casing opening into the cavity; a slinger having an outer edge, a center, a bottom slinger surface, a top slinger surface, and a plurality of slinger blades extending upwardly from the top slinger surface, wherein the slinger is attached to the drive shaft, and wherein the height of the top slinger surface above the bottom slinger surface continuously increases from the outer edge to the center; and an impeller having a bottom impeller surface and a plurality of impeller blades extending downwardly from the bottom impeller surface, wherein the impeller is positioned below the slinger and is attached to the drive shaft.

WO 2016/153883 A1

LV, MC, MK, MT, NL, NO, PL, PT, RO, RS, SE, SI, SK, **Published:**  
SM, TR), OAPI (BF, BJ, CF, CG, CI, CM, GA, GN, GQ, — *with international search report (Art. 21(3))*  
GW, KM, ML, MR, NE, SN, TD, TG).

## **BLENDER FOR MIXING AND PUMPING SOLIDS AND FLUIDS AND METHOD OF USE THEREOF**

### CROSS-REFERENCE TO RELATED APPLICATIONS

**[0001]** The present document is based on and claims priority to U.S. Non-Provisional Application Serial No.: 14/668,032, filed March 25, 2015, which is incorporated herein by reference in its entirety.

### FIELD

**[0002]** The disclosure generally relates to an apparatus and methods for mixing and pumping solids and fluids, and more particularly, but not by way of limitation, apparatus and methods for mixing and pumping solids and fluids including use of a slinger having a top surface with a convex or spline type shape.

### BACKGROUND

**[0003]** The statements in this section merely provide background information related to the disclosure and may not constitute prior art.

**[0004]** In the oil and gas drilling and production industry, viscous aqueous fluids are commonly used in treating subterranean wells, as well as carrier fluids. Such fluids may be used as fracturing fluids, acidizing fluids, and high-density completion fluids. In an operation known as well fracturing, such fluids are used to initiate and propagate underground fractures for increasing petroleum productivity.

**[0005]** During fracturing operations, fluids pumped into the subterranean formation can include solids such as proppant mixed with a fluid such as an aqueous gel. Such proppant-containing fluids are mixed in a blender including a slinger and a pump impeller, each attached to a drive shaft and enclosed within a casing. In recent years, fluids containing elevated levels of solids have been used resulting in substantial increases in wear and tear on the blender internals and resulting in decreased mixing and pumping efficiency.

**[0006]** Therefore, there is a need for efficient apparatus and methods useful for mixing and pumping solids and fluids with decreased wear and tear, such need

met, at least in part, by the following disclosure.

#### SUMMARY

**[0007]** In an embodiment, a blender is disclosed including: a casing defining a cavity and having a top casing surface and a bottom casing surface; a drive shaft extending through a casing opening into the cavity; a slinger having an outer edge, a center, a bottom slinger surface facing the bottom casing surface, a top slinger surface facing the top casing surface, and a plurality of slinger blades extending upwardly from the top slinger surface, wherein the slinger is attached to the drive shaft, and wherein the height of the top slinger surface above the bottom slinger surface continuously increases from the outer edge to the center; and an impeller having a bottom impeller surface facing the bottom casing surface and a plurality of impeller blades extending downwardly from the bottom impeller surface, wherein the impeller is positioned below the slinger and is attached to the drive shaft.

**[0008]** In accordance with another embodiment, a slinger and impeller assembly is disclosed and includes: a drive shaft; a slinger having an outer edge, a center, a bottom slinger surface, a top slinger surface, and a plurality of slinger blades extending upwardly from the top slinger surface, wherein the slinger is attached to the drive shaft, and wherein the height of the top slinger surface above the bottom slinger surface continuously increases from the outer edge to the center; and an impeller having a bottom impeller surface and a plurality of impeller blades extending downwardly from the bottom impeller surface, wherein the impeller is positioned below the slinger and is attached to the drive shaft.

**[0009]** In accordance with another embodiment, a method is disclosed and includes utilizing the above described blender by introducing a proppant into a top casing opening defined by the top casing surface for contact with the top slinger surface, introducing a fluid to the impeller, mixing the proppant and the fluid to form a mixture, and discharging the mixture through an outlet of the blender.

#### BRIEF DESCRIPTION OF THE DRAWINGS

**[0010]** Certain embodiments of the disclosure will hereafter be described with reference to the accompanying drawings, wherein like reference numerals denote

like elements. It should be understood, however, that the accompanying figures illustrate the various implementations described herein and are not meant to limit the scope of various technologies described herein.

**[0011]** Figure 1 illustrates some embodiments in accordance with the disclosure in side view and cross section.

**[0012]** Figure 2 illustrates some embodiments in accordance with the disclosure in side view and cross section.

**[0013]** Figure 2A depicts a bottom plan view of blender 100 of Figure 2 in accordance with some embodiments of the disclosure.

**[0014]** Figure 3 illustrates some embodiments in accordance with the disclosure in side view.

**[0015]** Figure 4 illustrates some embodiments in accordance with the disclosure in side view.

**[0016]** Figure 5 illustrates some embodiments in accordance with the disclosure in top view.

**[0017]** Figure 6A depicts an open impeller in accordance with some embodiments of the disclosure.

**[0018]** Figure 6B depicts a semi-open impeller in accordance with some embodiments of the disclosure.

**[0019]** Figure 6C depicts a closed impeller in accordance with some embodiments of the disclosure.

**[0020]** Figure 7 illustrates some embodiments in accordance with the disclosure in bottom view.

**[0021]** Figure 8 illustrates some embodiments in accordance with the disclosure in side view.

**[0022]** Figure 9 illustrates some embodiments in accordance with the disclosure in top view.

## DETAILED DESCRIPTION

**[0023]** In the following description, numerous details are set forth to provide an understanding of some embodiments of the present disclosure. However, it will be understood by those of ordinary skill in the art that the system and/or methodology may be practiced without these details and that numerous variations or modifications from the described embodiments may be possible.

**[0024]** Unless expressly stated to the contrary, "or" refers to an inclusive or and not to an exclusive or. For example, a condition A or B is satisfied by anyone of the following: A is true (or present) and B is false (or not present), A is false (or not present) and B is true (or present), and both A and B are true (or present).

**[0025]** In addition, use of the "a" or "an" are employed to describe elements and components of the embodiments herein. This is done merely for convenience and to give a general sense of the inventive concept. This description should be read to include one or at least one and the singular also includes the plural unless otherwise stated.

**[0026]** The terminology and phraseology used herein is for descriptive purposes and should not be construed as limiting in scope. Language such as "including," "comprising," "having," "containing," or "involving," and variations thereof, is intended to be broad and encompass the subject matter listed thereafter, equivalents, and additional subject matter not recited.

**[0027]** Finally, as used herein any references to "one embodiment" or "an embodiment" means that a particular element, feature, structure, or characteristic described in connection with the embodiment is included in at least one embodiment. The appearances of the phrase "in one embodiment" in various places in the specification are not necessarily referring to the same embodiment.

**[0028]** Some aspects of the disclosure relate to apparatus for, and methods for, mixing solids and fluids.

**[0029]** With reference to Figures 1 and 2, in some embodiments, the blender 100 can comprise, consist of, or consist essentially of a: i) casing 102 defining a cavity 104 and having a top casing surface 106 and a bottom casing surface 108, a

fluid entry 109 defined by bottom casing surface 108, a top casing opening 112 defined by top casing surface 106, and a slurry discharge 113; ii) a drive shaft 110 extending through a casing opening into the cavity 104 (shown as drive shaft 10 extending through top casing opening 112 in Figure 1, and shown in Figure 2 as drive shaft 10 extending through opening 114 defined by a fluid inlet conduit 109A connected in fluid flow communication with bottom casing opening 109); iii) a slinger 116 having an outer edge 118, a center 120, a bottom slinger surface 122 facing the bottom casing surface 108, a top slinger surface 124 facing the top casing surface 106, and a plurality of slinger blades 126 extending upwardly from the top slinger surface 124, wherein the slinger 116 is attached to the drive shaft 110, and wherein the height of the top slinger surface 124 above the bottom slinger surface 122 continuously increases from the outer edge 118 to the center 120; and iv) an impeller 128 having a bottom impeller surface 130 facing the bottom casing surface 108 and a plurality of impeller blades 132 extending downwardly from the bottom impeller surface 130, wherein the impeller 128 is positioned below the slinger 116 and is attached to the drive shaft 110. When the drive shaft 110 extends through the opening 114, as shown in Figure 2 and Figure 2A, which is a bottom view of blender 100, the drive shaft 110 is in sealing engagement with fluid inlet conduit 109A while still allowing free rotation of the drive shaft 110. The slinger blades 126 of the slinger 116 can be open to the top casing surface 106 as shown in Figures 1 and 2, or can be at least partially closed off to the top casing surface 106 (not shown, but with a configuration similar to the closed impeller shown in Figure 6C). The slinger blades 126 are shown having an upper surface parallel to the top casing surface 106, but can have any configuration between parallel to the top slinger surface 124 up to parallel to the top casing surface 106.

**[0030]** In accordance with an embodiment, Figure 3 shows a side view of the slinger 116 and impeller 128 wherein the impeller is secured to the slinger. In accordance with an embodiment, the top slinger surface 124 can have a convex shape as shown in Figures 1-3. With reference to Figure 3, A is the height of the top slinger surface 124 above the bottom slinger surface 122 at or near the center 120 of the slinger 116; B is the height of the top slinger surface 124 above the bottom slinger surface 122 at or near the outer edge 118 of the slinger 116; and the ratio of A to B is up to about 20:1 or up to about 10:1 or up to about 5:1. In accordance with

an embodiment, the slinger 116 can further comprise breathing holes 131 providing passage ways for entrained air to pass out of the top casing opening 112 (as shown in Figures 1 and 2) of blender 100. The term “at or near” for the “center 120” and the “outer edge 118”, as used herein, can range up to a distance of 5% or 10% of the radius of the slinger 116.

**[0031]** In accordance with an embodiment, Figure 4 shows a side view of the slinger 116 and impeller 128 wherein the top slinger surface 124 is depicted as having a spline-type shape.

**[0032]** In accordance with an embodiment, the area of the top casing opening 112 in the top casing surface 106 can be from about 15% to about 60% or from about 25% to about 50% or from about 35% to about 40% of the total area of the top casing surface 106.

**[0033]** In accordance with an embodiment, when the drive shaft 110 extends downwardly through the top casing opening 112 into the cavity as shown in Figure 1, the blender can further comprise a hub 134 attached to the top slinger surface 124; wherein the drive shaft 110 can be attached to the hub 134 and the impeller 128 can be attached to the slinger 116 (as shown in Figures 3 and 4).

**[0034]** In accordance with an embodiment as shown in Figure 5, which is a top view of slinger 116, the plurality of slinger blades 126 can each have an inner end which is substantially tangential to an inner circumference (indicated by the arrow) of the top slinger surface 124.

**[0035]** In accordance with an embodiment, and with reference to Figure 1, C is a vertical distance from any point along the top of the plurality of slinger blades 126 to the top casing surface 106 and D is a distance at a corresponding horizontal point from the top of the plurality of slinger blades 126 to the top slinger surface 124. Figure 1 shows the distances at one particular point, but it should be understood that the distances C and D can be measured at any point along the top of the plurality of slinger blades 126. In accordance with an embodiment, the ratio of C to D can be between about 0.1:1 to about 2:1 or from about 0.1:1 to about 1.5:1 or from about 0.5:1 to about 1:1.



**[0036]** In accordance with an embodiment, and with reference to Figures 6a – 6c, the impeller 128 can be selected from the group consisting of: an open impeller (depicted in Figure 6a), a semi-open impeller (depicted in Figure 6b), and a closed impeller (depicted in Figure 6c). Open impellers comprise blades attached to a drive shaft, semi-open impellers are constructed with a circular plate (the web) attached to one side of the blades, and enclosed impellers have circular plates attached to both sides of the blades. Enclosed impellers can also be referred to as shrouded impellers.

**[0037]** In accordance with an embodiment, and as shown in Figure 7 (which is a bottom view of impeller 128) and Figure 1, the impeller 128 can further comprise a bottom plate 129 attached to the bottom of the impeller blades 132, and a plurality of pump out vanes 136 extending from the bottom plate 129 toward the bottom casing surface 108; E is a distance from the bottom surface of the pump out vanes 136 to the bottom casing surface 108; F is a distance from the bottom surface of the pump out vanes 136 to the bottom plate 129; and the ratio of E to F is at most about 2.5:1 or at most 2.0:1 or at most 1.5:1.

**[0038]** In accordance with an embodiment, and with reference to Figure 8 which is a side view the slinger 116 and the impeller 128, and Figure 9 which is a top view of the slinger 116 shown in Figure 8, the slinger 116 can further comprise a substantially flat edge 138 extending radially from the outer edge 118 and comprising a substantially flat edge top surface 140, wherein the height of the substantially flat edge top surface 140 above the bottom slinger surface 122 is within 5% or 3% or 2% of the height of the top slinger surface 124 above the bottom slinger surface 122 at the outer edge 118; and wherein the width of the substantially flat edge 138 is at most 50% or at most 35% or at most 25% of the radius of the slinger 116.

**[0039]** In accordance with an embodiment, and with reference to either Figure 1 or Figure 2, a method for mixing a solid with a fluid can comprise, consist of, or consist essentially of: utilizing a blender 100 in accordance with any of the above described embodiments; introducing a solid into the top casing opening 112; introducing a fluid to the impeller 128 through bottom casing opening 109; mixing the solid with the fluid thereby forming a mixture; and discharging the mixture from the

blender through slurry discharge 113. In accordance with an embodiment, the solid can comprise a solid component selected from the group consisting of a proppant, a powder, a fiber, and combinations thereof; and the fluid can comprise a fluid component selected from the group consisting of water, a gel, and combinations thereof.

**[0040]** With reference to Figures 1-3, and in accordance with an embodiment, entrained air in the mixture can be drawn through the breathing holes 131 depicted in Figure 3 and escape the blender 100 through the top casing opening 112 depicted in Figures 1 and 2.

**[0041]** The foregoing description of the embodiments has been provided for purposes of illustration and description. Example embodiments are provided so that this disclosure will be thorough, and will fully convey the scope to those who are skilled in the art. Numerous specific details are set forth such as examples of specific components, devices, and methods, to provide a thorough understanding of embodiments of the disclosure, but are not intended to be exhaustive or to limit the disclosure. Individual elements or features of a particular embodiment are generally not limited to that particular embodiment, but, where applicable, are interchangeable and can be used in a selected embodiment, even if not specifically shown or described. The same may also be varied in many ways. Such variations are not to be regarded as a departure from the disclosure, and all such modifications are intended to be included within the scope of the disclosure.

**[0042]** It will be apparent to those skilled in the art that specific details need not be employed, that example embodiments may be embodied in many different forms and that neither should be construed to limit the scope of the disclosure. In some example embodiments, well-known processes, well-known device structures, and well-known technologies are not described in detail. Further, it will be readily apparent to those of skill in the art that in the design, manufacture, and operation of apparatus to achieve that described in the disclosure, variations in apparatus design, construction, condition, erosion of components, gaps between components may be present, for example.

**[0043]** Although the terms first, second, third, etc. may be used herein to

describe various elements, components, regions, layers and/or sections, these elements, components, regions, layers and/or sections should not be limited by these terms. These terms may be only used to distinguish one element, component, region, layer or section from another region, layer or section. Terms such as "first," "second," and other numerical terms when used herein do not imply a sequence or order unless clearly indicated by the context. Thus, a first element, component, region, layer or section discussed below could be termed a second element, component, region, layer or section without departing from the teachings of the example embodiments.

**[0044]** Spatially relative terms, such as "inner," "outer," "center," "beneath," "below," "lower," "above," "upper," "top," "bottom" and the like, may be used herein for ease of description to describe one element or feature's relationship to another element(s) or feature(s) as illustrated in the figures. Spatially relative terms may be intended to encompass different orientations of the device in use or operation in addition to the orientation depicted in the figures. For example, if the device in the figures is turned over, elements described as "below" or "beneath" other elements or features would then be oriented "above" the other elements or features. Thus, the example term "below" can encompass both an orientation of above and below. The device may be otherwise oriented (rotated 90 degrees or at other orientations) and the spatially relative descriptors used herein interpreted accordingly.

**[0045]** Although various embodiments have been described with respect to enabling disclosures, it is to be understood the invention is not limited to the disclosed embodiments. Variations and modifications that would occur to one of skill in the art upon reading the specification are also within the scope of the invention, which is defined in the appended claims.

## CLAIMS

What is claimed is:

1. A blender comprising:

a casing defining a cavity and having a top casing surface and a bottom casing surface;

a drive shaft extending through a casing opening into the cavity;

a slinger having an outer edge, a center, a bottom slinger surface facing the bottom casing surface, a top slinger surface facing the top casing surface, and a plurality of slinger blades extending upwardly from the top slinger surface, wherein the slinger is attached to the drive shaft, and wherein the height of the top slinger surface above the bottom slinger surface continuously increases from the outer edge to the center; and

an impeller having a bottom impeller surface facing the bottom casing surface and a plurality of impeller blades extending downwardly from the bottom impeller surface, wherein the impeller is positioned below the slinger and is attached to the drive shaft.

2. The blender of claim 1 wherein A is the height of the top slinger surface above the bottom slinger surface at or near the center of the slinger; B is the height of the top slinger surface above the bottom slinger surface at or near the outer edge of the slinger; and the ratio of A to B is up to about 20:1.
3. The blender of claim 1 wherein the drive shaft extends upwardly through a bottom casing opening defined by the bottom casing surface into the cavity.
4. The blender of claim 3 wherein the top casing surface defines a top casing opening.

5. The blender of claim 4 wherein the area of the top casing opening in the top casing surface is from about 15% to about 60% of the total area of the top casing surface.
6. The blender of claim 1 wherein the top casing surface defines a top casing opening, and wherein the drive shaft extends downwardly through the top casing opening into the cavity.
7. The blender of claim 6 wherein the area of the top casing opening in the top casing surface is from about 15% to about 60% of the total area of the top casing surface.
8. The blender of claim 1 wherein the top slinger surface has a convex shape.
9. The blender of claim 1 wherein the top slinger surface has a spline-type shape.
10. The blender of claim 1 wherein the plurality of slinger blades each have an inner end which is substantially tangential to an inner circumference of the top slinger surface.
11. The blender of claim 1 wherein C is a distance from the top of the plurality of slinger blades to the top casing surface; D is a distance from the top of the plurality of slinger blades to the top slinger surface; and the ratio of C to D is between about 0.1:1 to about 2:1.
12. The blender of claim 1 wherein the impeller further comprises a bottom plate attached to the bottom of the impeller blades, and a plurality of pump out vanes extending from the bottom plate toward the bottom casing surface; E is a distance from the bottom surface of the pump out vanes to the bottom casing surface; F is a distance from the bottom surface of the pump out vanes to the bottom plate; and the ratio of E to F is at most about 1.5:1.

13. The blender of claim 1 wherein the slinger further comprises a substantially flat edge extending radially from the outer edge and comprising a substantially flat edge top surface, wherein the height of the substantially flat edge top surface above the bottom slinger surface is within 5% of the height of the top slinger surface above the bottom slinger surface at the outer edge; and wherein the width of the substantially flat edge is at most 25% of the radius of the slinger.
14. A slinger and impeller assembly comprising:
- a drive shaft;
  - a slinger having an outer edge, a center, a bottom slinger surface, a top slinger surface, and a plurality of slinger blades extending upwardly from the top slinger surface, wherein the slinger is attached to the drive shaft, and wherein the height of the top slinger surface above the bottom slinger surface continuously increases from the outer edge to the center; and
  - an impeller having a bottom impeller surface and a plurality of impeller blades extending downwardly from the bottom impeller surface, wherein the impeller is positioned below the slinger and is attached to the drive shaft.
15. The slinger and impeller assembly of claim 14 wherein A is the height of the top slinger surface above the bottom slinger surface at or near the center of the slinger; B is the height of the top slinger surface above the bottom slinger surface at or near the outer edge of the slinger; and the ratio of A to B is up to about 20:1.
16. The slinger and impeller assembly of claim 14 wherein the top slinger surface has a convex shape.

17. The slinger and impeller assembly of claim 14 wherein the top slinger surface has a spline-type shape.

18. The slinger and impeller assembly of claim 14 wherein the slinger further comprises a substantially flat edge extending radially from the outer edge and comprising a substantially flat edge top surface, wherein the height of the substantially flat edge top surface above the bottom slinger surface is within 5% of the height of the top slinger surface above the bottom slinger surface at the outer edge; and wherein the width of the substantially flat edge is at most 25% of the radius of the slinger.

19. A method for mixing a solid with a fluid comprising:

utilizing a blender comprising:

a casing defining a cavity and having a top casing surface and a bottom casing surface, wherein the top casing surface defines a top casing opening;

a drive shaft extending through a casing opening into the cavity;

a slinger having an outer edge, a center, a bottom slinger surface facing the bottom casing surface, a top slinger surface facing the top casing surface, and a plurality of slinger blades extending upwardly from the top slinger surface, wherein the slinger is attached to the drive shaft, and wherein the height of the top slinger surface above the bottom slinger surface continuously increases from the outer edge to the center; and

an impeller having a bottom impeller surface facing the bottom casing surface and a plurality of impeller blades extending downwardly from the bottom impeller surface, wherein the impeller is positioned below the slinger and is attached to the drive shaft;

introducing a solid into the top casing opening;

introducing a fluid to the impeller through a bottom casing opening of the casing;

mixing the solid with the fluid thereby forming a mixture; and

discharging the mixture from the blender.

20. The method of claim 19 wherein the solid comprises a proppant and the fluid comprises water.

21. The method of claim 19 wherein the slinger further comprises breathing holes, and wherein entrained air in the mixture is drawn through the breathing holes and escapes the blender through the top casing opening.



1/8

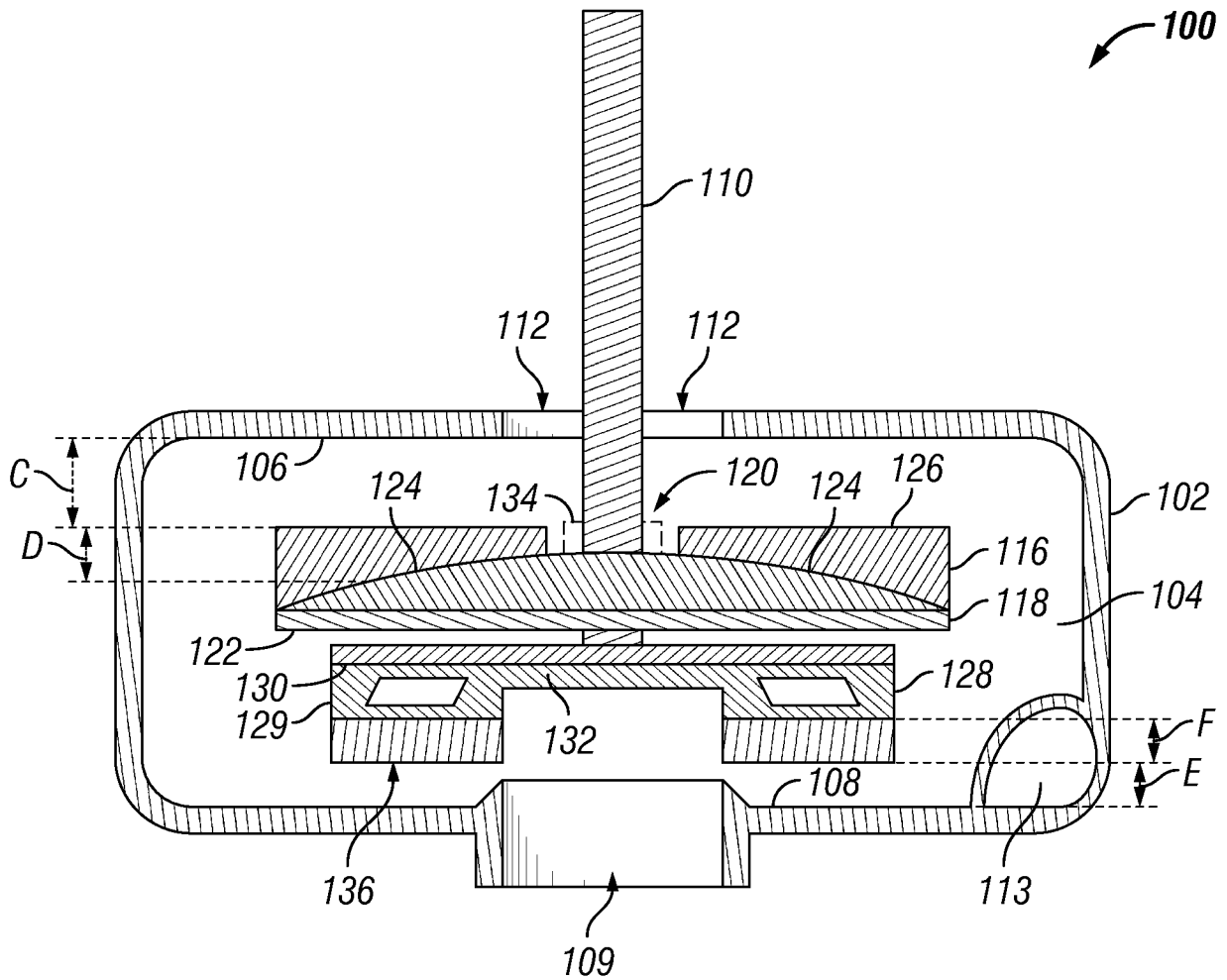


FIG. 1

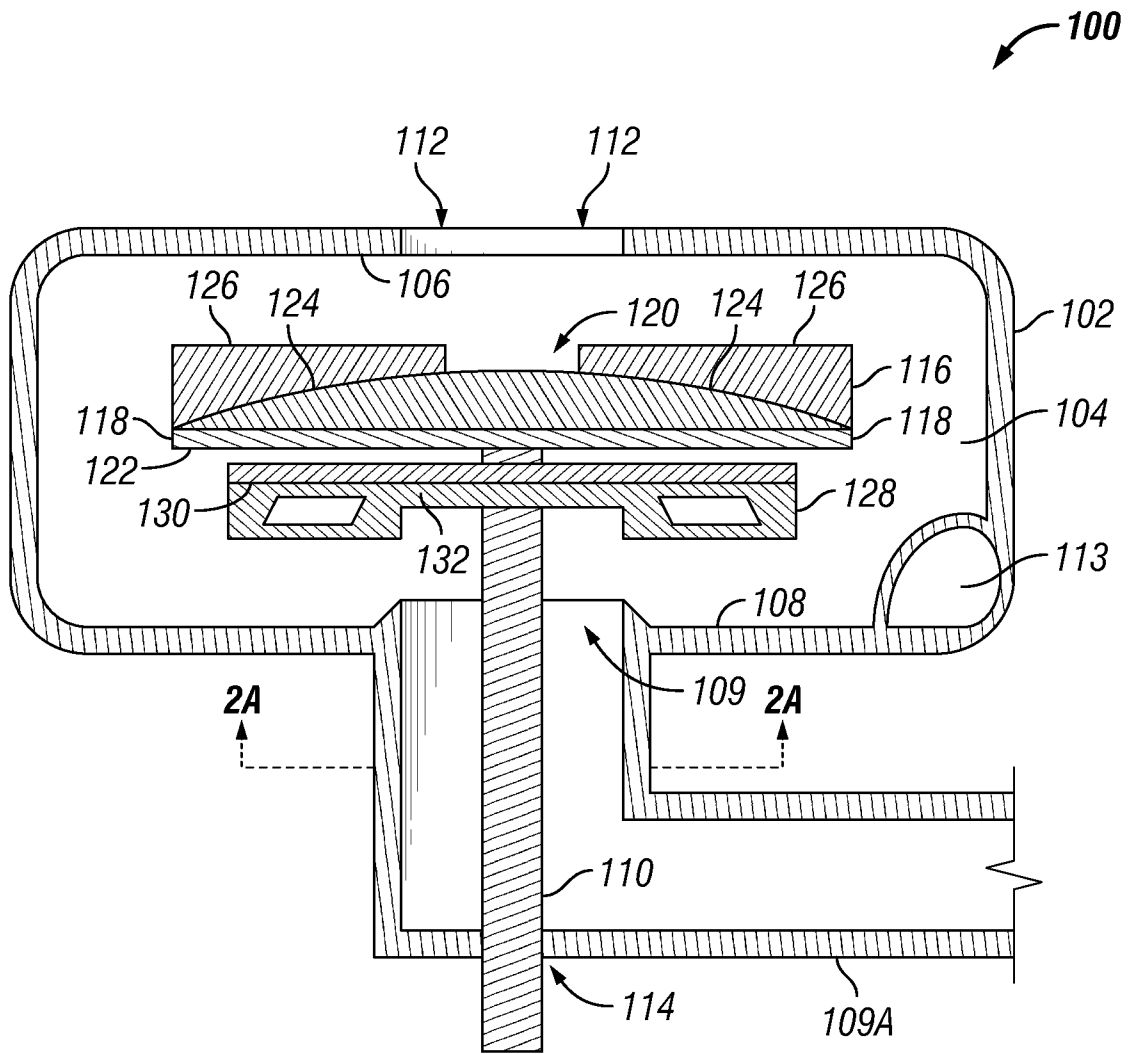
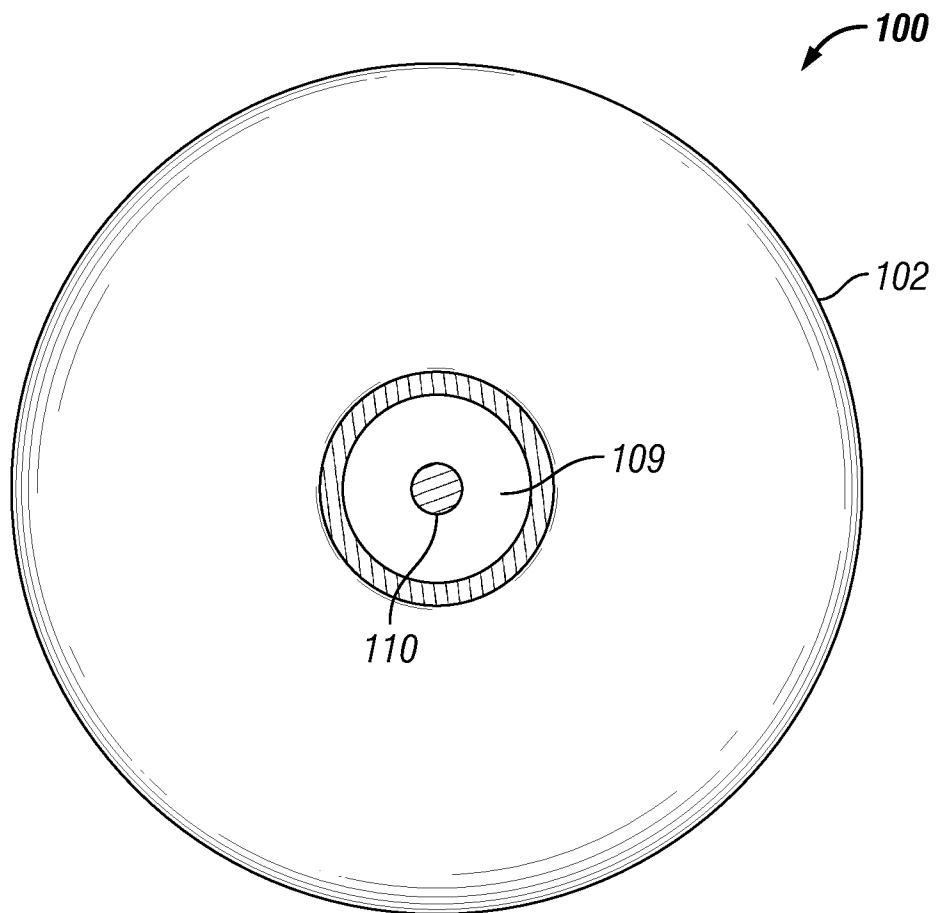


FIG. 2

3/8



**FIG. 2A**

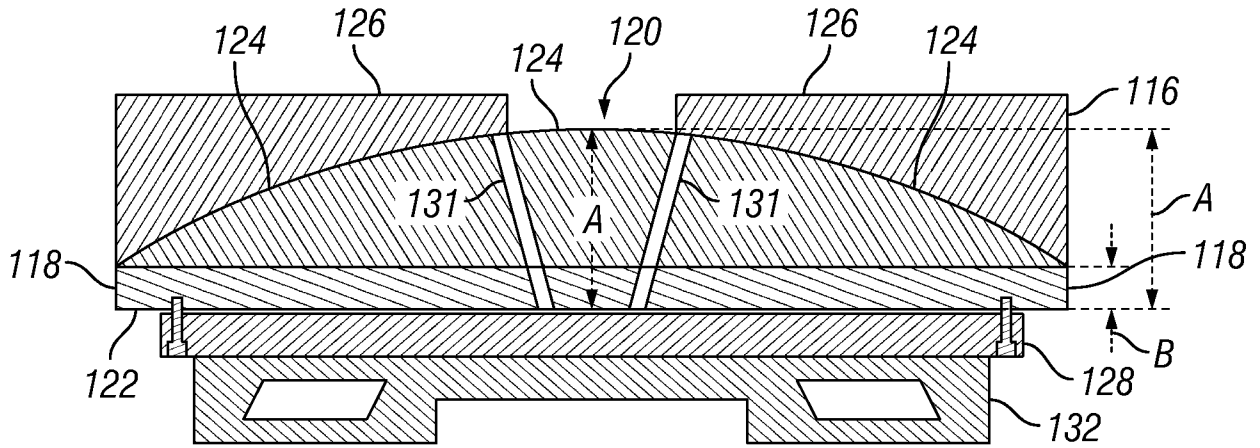


FIG. 3

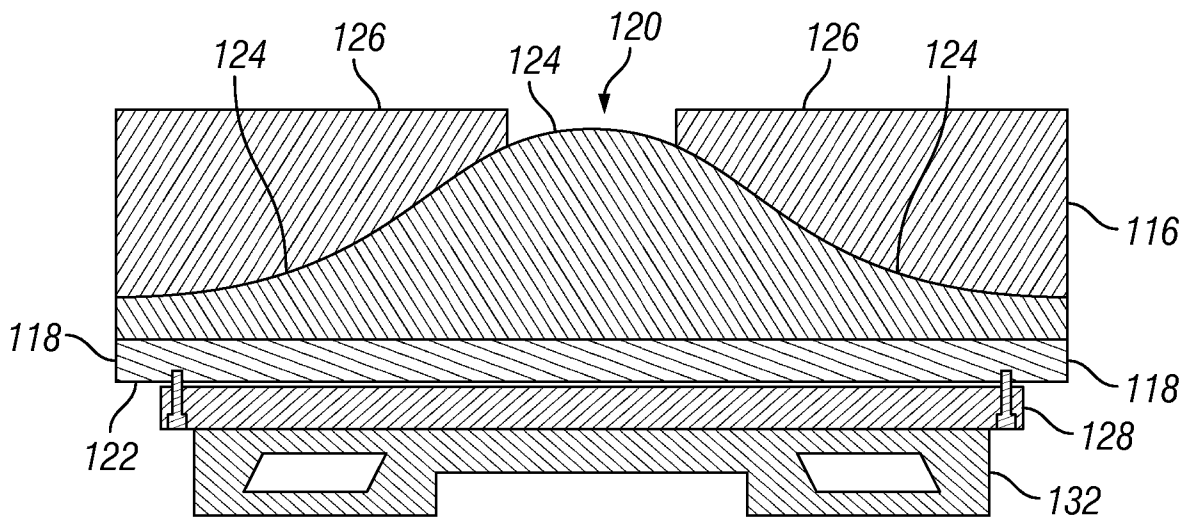


FIG. 4

5/8

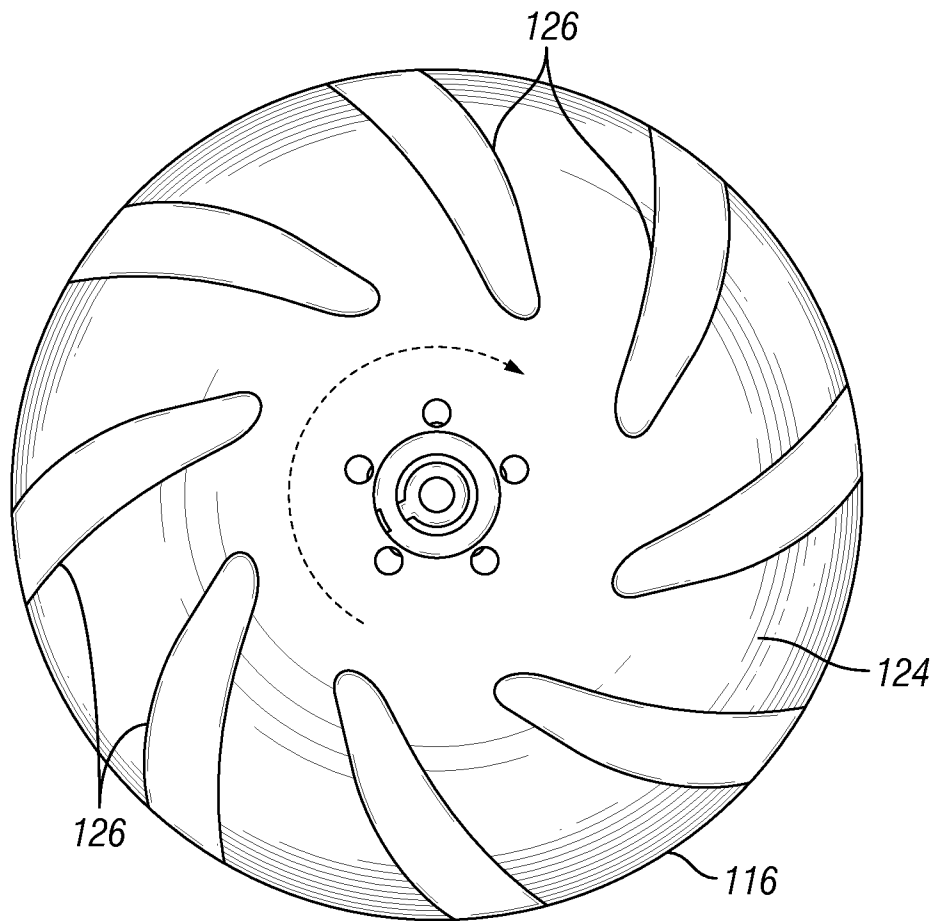
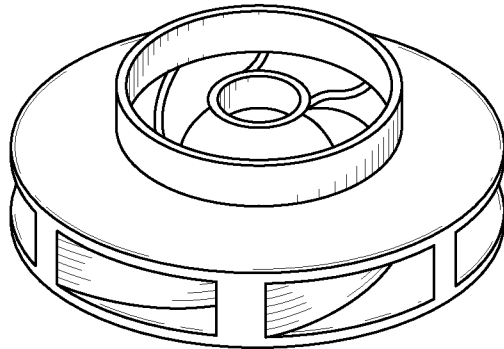
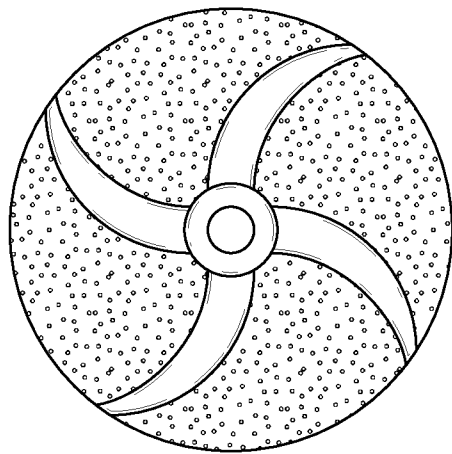


FIG. 5

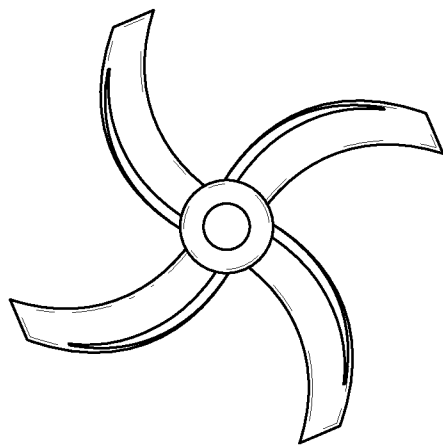
6/8



**FIG. 6C**

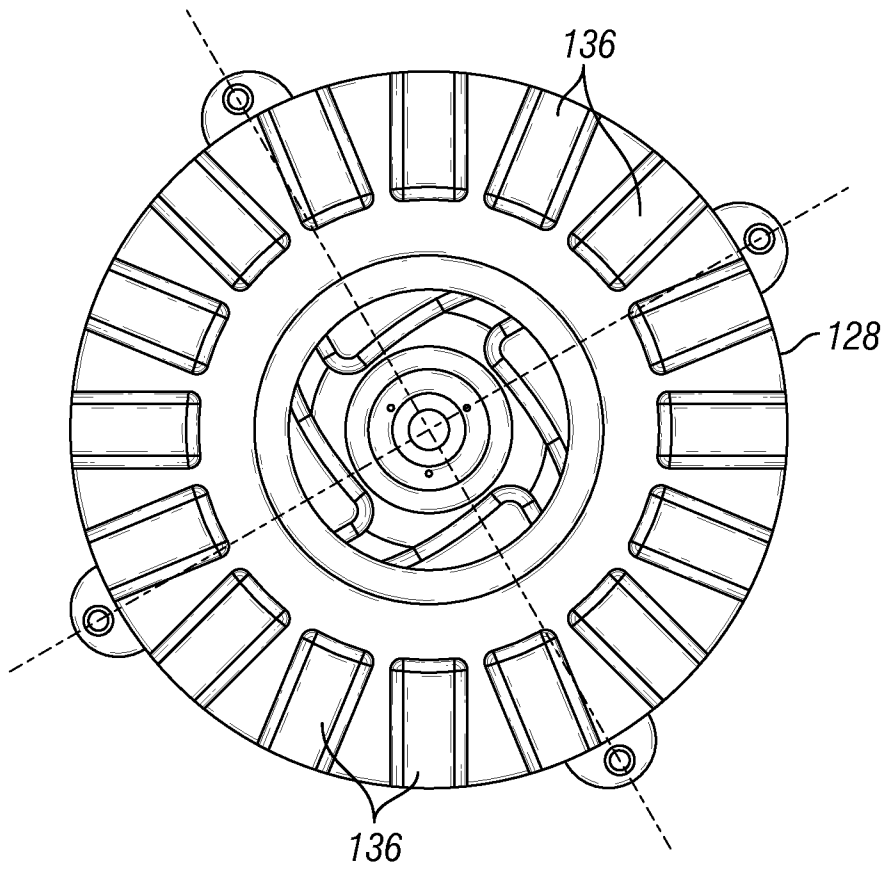


**FIG. 6B**



**FIG. 6A**

7/8



**FIG. 7**

8/8

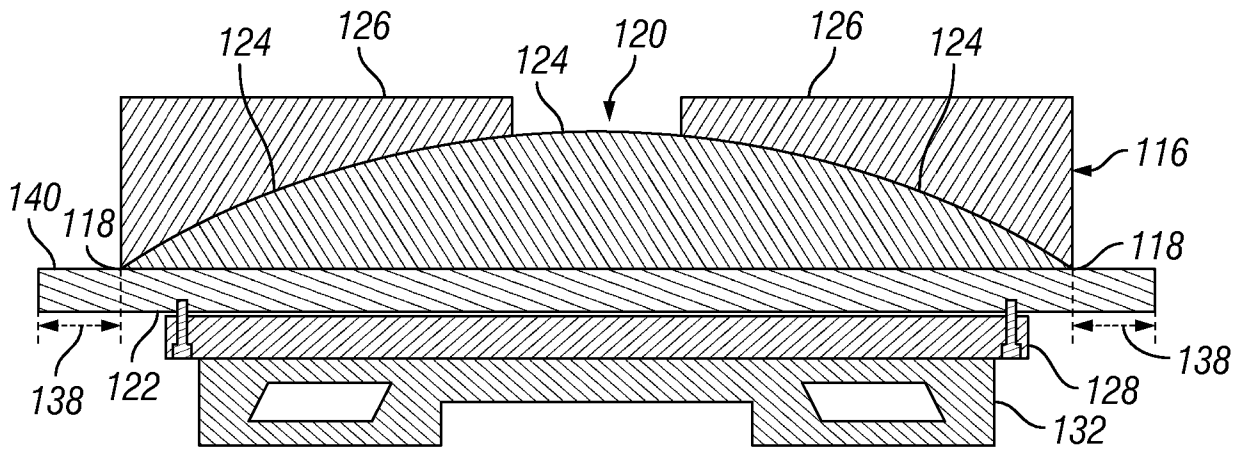


FIG. 8

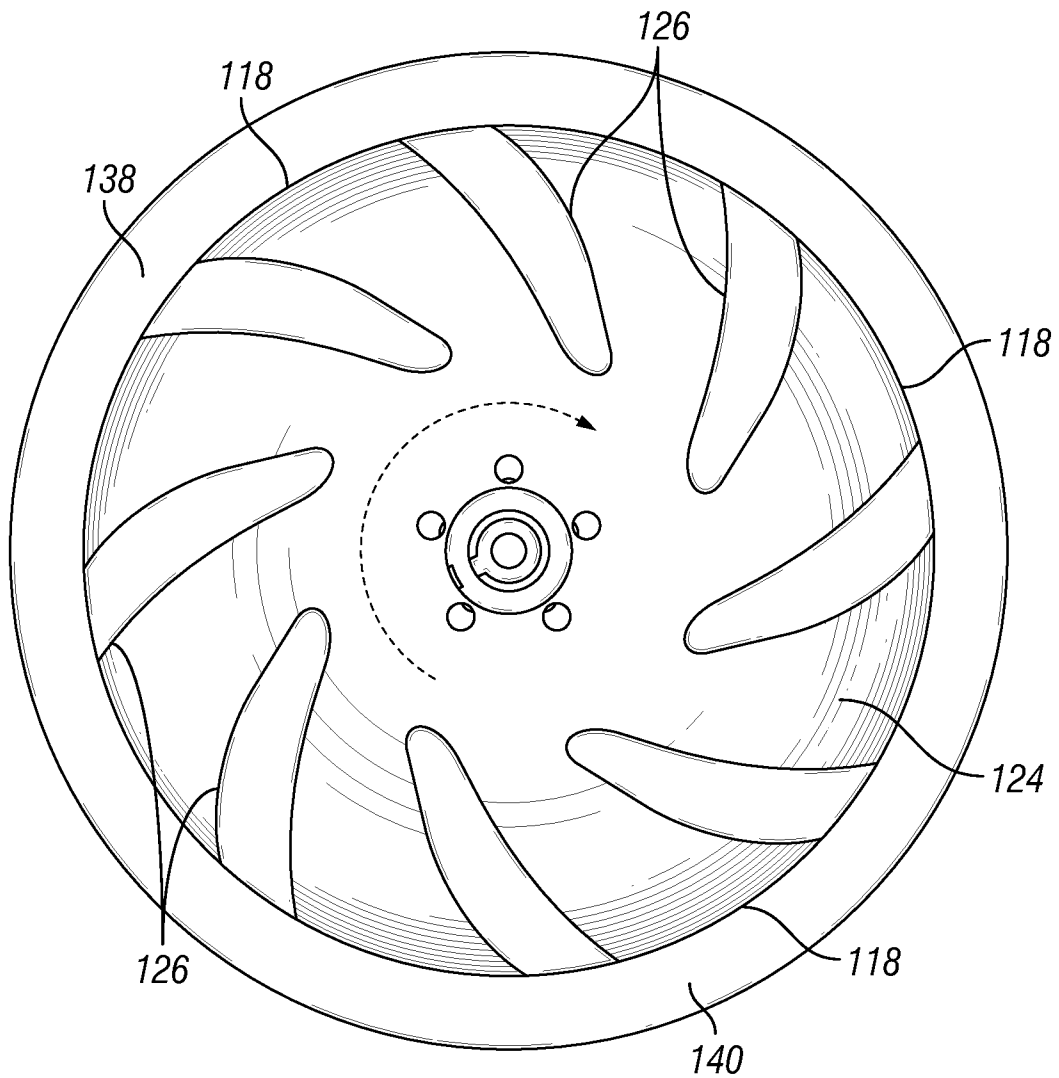


FIG. 9



**A. CLASSIFICATION OF SUBJECT MATTER****B01F 7/22(2006.01)i, B01F 3/12(2006.01)i, B01F 15/00(2006.01)i**

According to International Patent Classification (IPC) or to both national classification and IPC

**B. FIELDS SEARCHED**Minimum documentation searched (classification system followed by classification symbols)  
B01F 7/22; B01F 3/12; B28C 5/00; B01F 7/16; B01F 15/02; B01F 15/00Documentation searched other than minimum documentation to the extent that such documents are included in the fields searched  
Korean utility models and applications for utility models  
Japanese utility models and applications for utility modelsElectronic data base consulted during the international search (name of data base and, where practicable, search terms used)  
eKOMPASS(KIPO internal) & keywords: blender, casing, shaft, impeller, slinger, blade, ratio**C. DOCUMENTS CONSIDERED TO BE RELEVANT**

Category*	Citation of document, with indication, where appropriate, of the relevant passages	Relevant to claim No.
A	US 8545091 B1 (ARRIBAU, J. O.) 1 October 2013 See abstract; figures 1-13; and claims 1-7.	1-21
A	US 6193402 B1 (GRIMLAND, K. E. et al.) 27 February 2001 See abstract; figures 4-5; and claims 1-13.	1-21
A	US 4453829 A (ALTHOUSE, III, J. W.) 12 June 1984 See abstract; figures 1-2; and claims 1-4.	1-21
A	US 4808004 A (MCINTIRE, W. R. et al.) 28 February 1989 See abstract; figures 1-3; and claims 1-10.	1-21
A	US 4671665 A (MCINTIRE, W. R.) 9 June 1987 See abstract; figures 1-3; and claims 1-8.	1-21

 Further documents are listed in the continuation of Box C. See patent family annex.

\* Special categories of cited documents:

"A" document defining the general state of the art which is not considered to be of particular relevance

"E" earlier application or patent but published on or after the international filing date

"L" document which may throw doubts on priority claim(s) or which is cited to establish the publication date of another citation or other special reason (as specified)

"O" document referring to an oral disclosure, use, exhibition or other means

"P" document published prior to the international filing date but later than the priority date claimed

"T" later document published after the international filing date or priority date and not in conflict with the application but cited to understand the principle or theory underlying the invention

"X" document of particular relevance; the claimed invention cannot be considered novel or cannot be considered to involve an inventive step when the document is taken alone

"Y" document of particular relevance; the claimed invention cannot be considered to involve an inventive step when the document is combined with one or more other such documents, such combination being obvious to a person skilled in the art

"&amp;" document member of the same patent family

Date of the actual completion of the international search

23 June 2016 (23.06.2016)

Date of mailing of the international search report

**24 June 2016 (24.06.2016)**

Name and mailing address of the ISA/KR

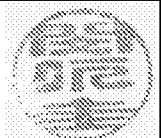
International Application Division  
Korean Intellectual Property Office  
189 Cheongsa-ro, Seo-gu, Daejeon, 35208, Republic of Korea

Facsimile No. +82-42-481-8578

Authorized officer

MIN, In Gyou

Telephone No. +82-42-481-3326



**INTERNATIONAL SEARCH REPORT**

Information on patent family members

International application No.

**PCT/US2016/022733**

Patent document cited in search report	Publication date	Patent family member(s)	Publication date
US 8545091 B1	01/10/2013	None	
US 6193402 B1	27/02/2001	US 2001-0000996 A1 US 6286986 B2	10/05/2001 11/09/2001
US 4453829 A	12/06/1984	EP 0145823 A1 EP 0145823 B1	26/06/1985 15/07/1987
US 4808004 A	28/02/1989	EP 0348558 A2	03/01/1990
US 4671665 A	09/06/1987	EP 0195484 A2 EP 0195484 B1 US 4614435 A	24/09/1986 27/12/1991 30/09/1986