

(12) **United States Patent**
Lee

(10) **Patent No.:** US 11,605,293 B2
(45) **Date of Patent:** Mar. 14, 2023

(54) **PARKING GUIDANCE APPARATUS AND METHOD**

(71) Applicant: **SK TELECOM CO., LTD.**, Seoul (KR)

(72) Inventor: **Seongsoo Lee**, Seoul (KR)

(73) Assignee: **SK TELECOM CO., LTD.**, Seoul (KR)

(*) Notice: Subject to any disclaimer, the term of this patent is extended or adjusted under 35 U.S.C. 154(b) by 160 days.

(21) Appl. No.: **17/054,984**

(22) PCT Filed: **Nov. 19, 2018**

(86) PCT No.: **PCT/KR2018/014168**

§ 371 (c)(1),

(2) Date: **Nov. 12, 2020**

(87) PCT Pub. No.: **WO2019/225820**

PCT Pub. Date: **Nov. 28, 2019**

(65) **Prior Publication Data**

US 2021/0327272 A1 Oct. 21, 2021

(30) **Foreign Application Priority Data**

May 21, 2018 (KR) 10-2018-0057738

(51) **Int. Cl.**
G08G 1/14 (2006.01)

(52) **U.S. Cl.**
CPC **G08G 1/143** (2013.01)

(58) **Field of Classification Search**
CPC G08G 1/143; G08G 1/096811; G08G 1/0969; G08G 1/146; G08G 1/14;
(Continued)

(56) **References Cited**

U.S. PATENT DOCUMENTS

11,125,577 B2* 9/2021 Alneghaimish G08G 1/04
2014/0118167 A1* 5/2014 Im G08G 1/096758
340/901

(Continued)

FOREIGN PATENT DOCUMENTS

JP 08-293097 A 11/1996
KR 10-2004-0002361 A 1/2004

(Continued)

OTHER PUBLICATIONS

PCT International Search Report and Written Opinion, PCT Application No. PCT/KR2018/014168, dated Feb. 28, 2019, 11 pages (with English translation of International Search Report).

Primary Examiner — Daryl C Pope

(74) *Attorney, Agent, or Firm* — Fenwick & West LLP

(57) **ABSTRACT**

A parking guidance apparatus according to an embodiment comprises: a storage unit for storing parking state information of a parking slot within a predetermined space; a communication unit for receiving, from a first vehicle, occupancy state information 0 of at least a part of the parking slot in the predetermined space; an update unit for updating the parking state information by using the received occupancy state information; and a control unit for, when the parking state information for the predetermined space is requested by a second vehicle through the communication unit, providing the second vehicle with a parking slot, which is in a parking-available state, determined on the basis of the updated parking state information.

11 Claims, 8 Drawing Sheets

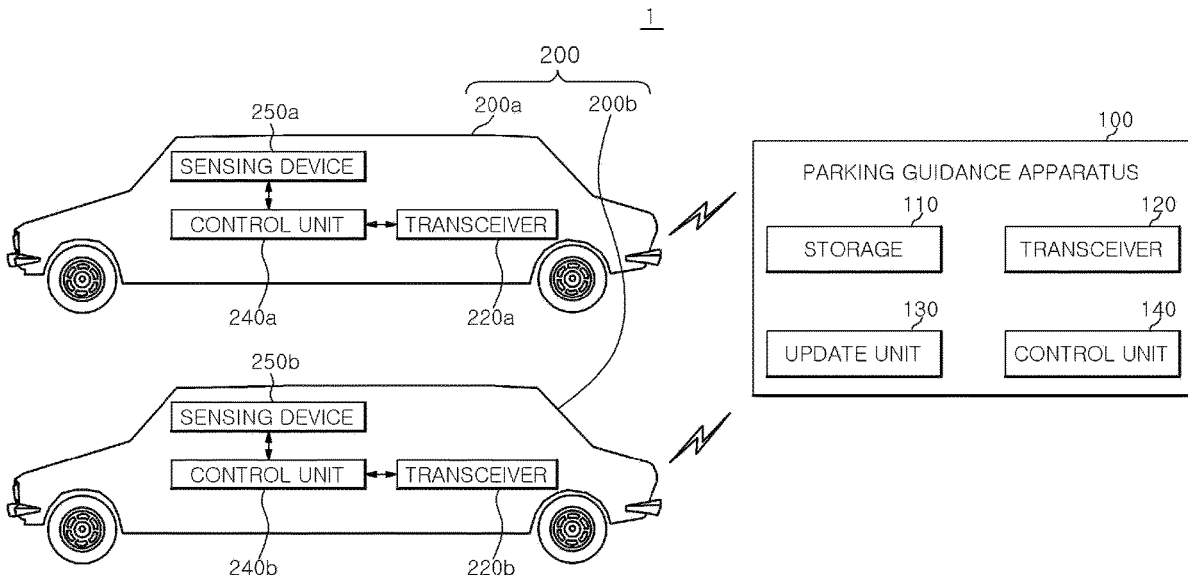

(58) **Field of Classification Search**

CPC G08G 1/0968; G08G 1/168; B60W 40/02;
B60W 2420/52; B60W 2420/54; B60W
2556/45; G01C 21/3453

See application file for complete search history.

(56) **References Cited**

U.S. PATENT DOCUMENTS

2016/0098929 A1* 4/2016 Nakhjavani G08G 1/0175
340/932.2
2017/0025008 A1* 1/2017 Gignac G06V 20/586
2018/0313661 A1* 11/2018 Eyster G08G 1/144

FOREIGN PATENT DOCUMENTS

KR 10-2014-0120489 A 10/2014
KR 10-1691312 B1 12/2016
KR 10-2017-0018563 A 2/2017

* cited by examiner

FIG. 1

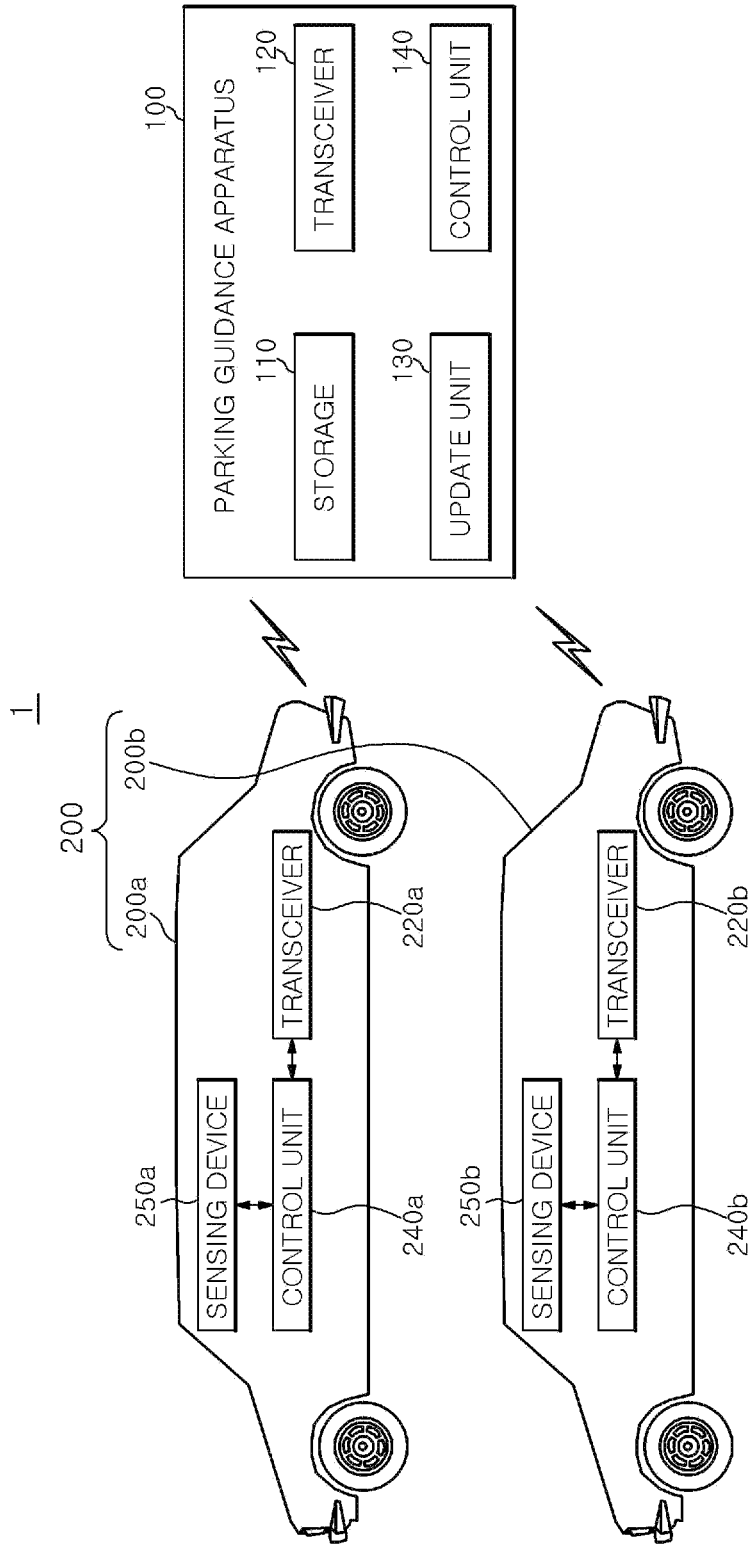

FIG. 2

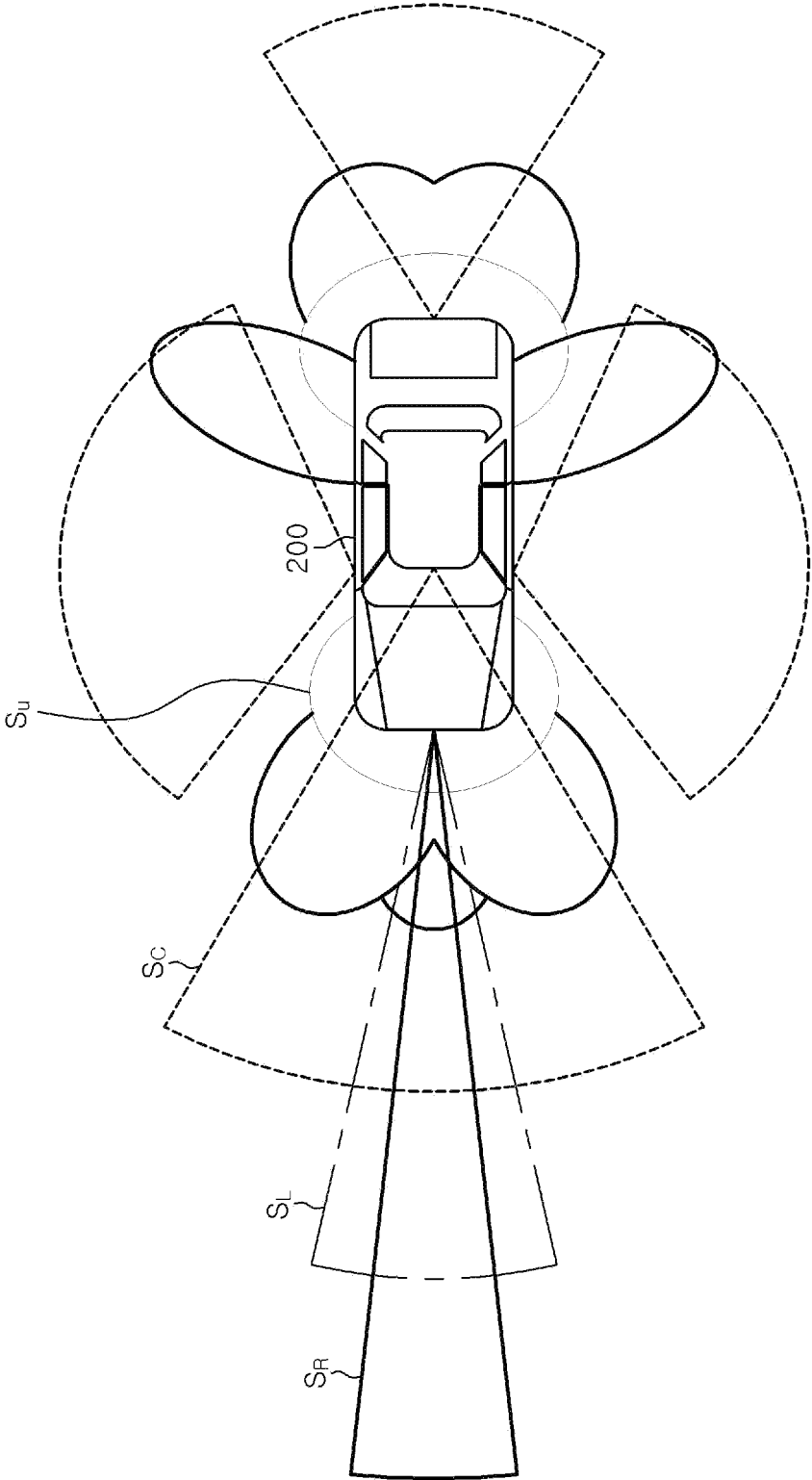

FIG. 3A

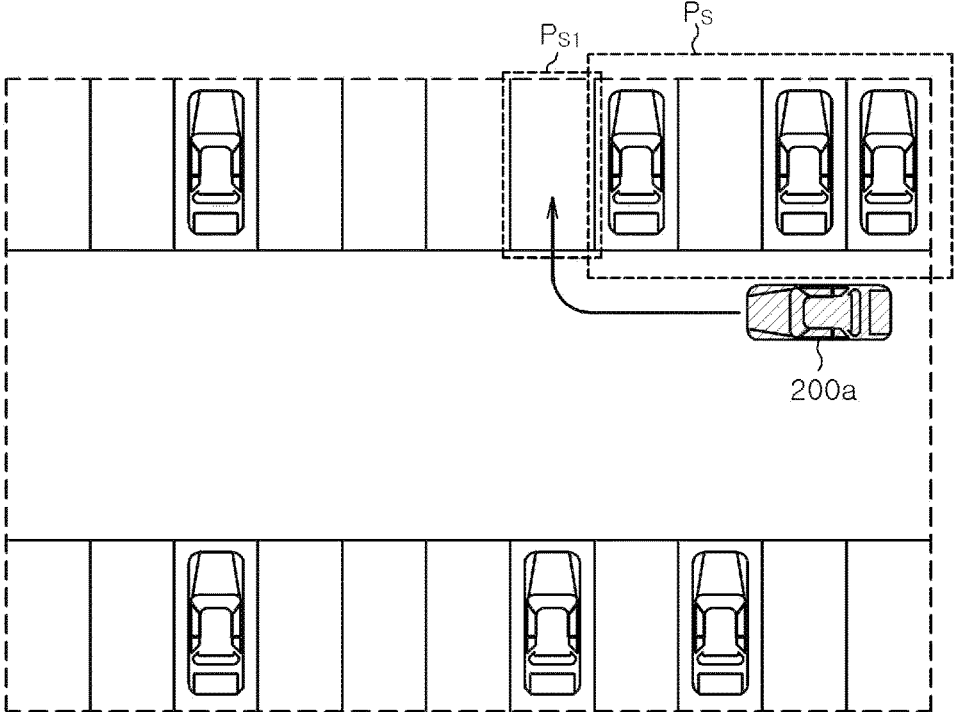

FIG. 3B

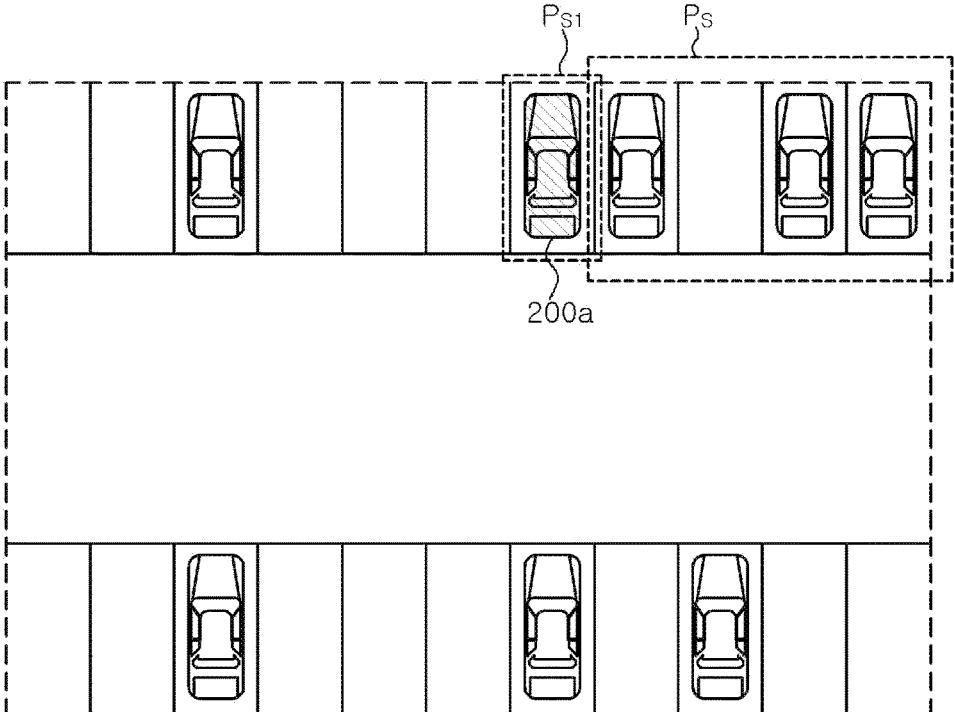

FIG. 4

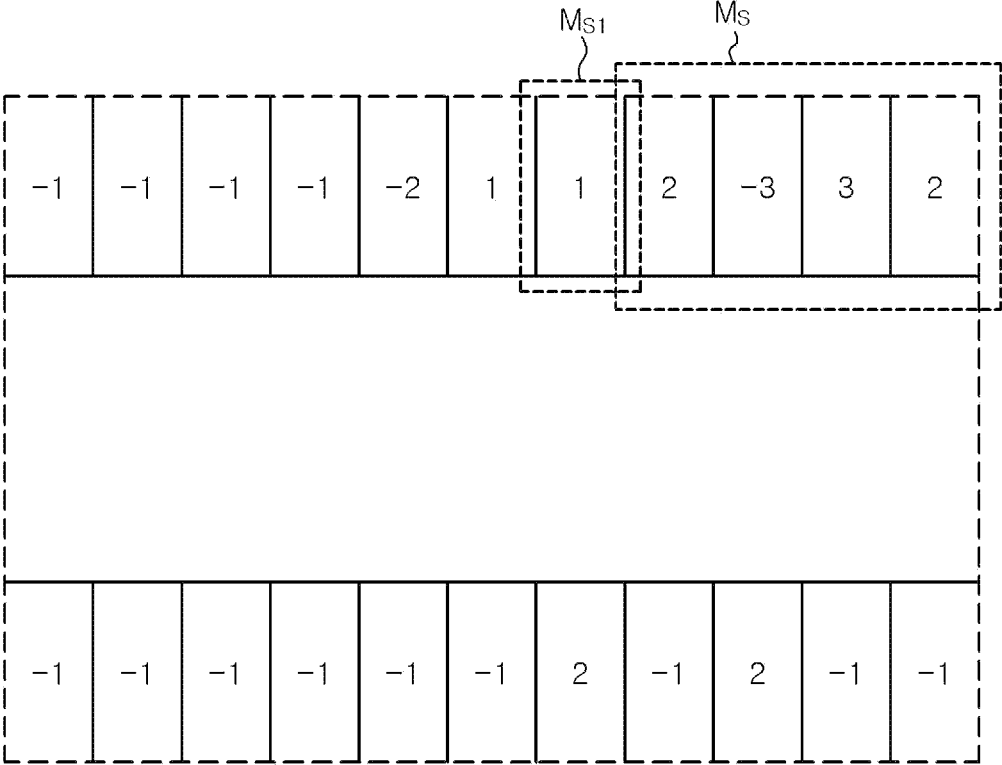

FIG. 5A

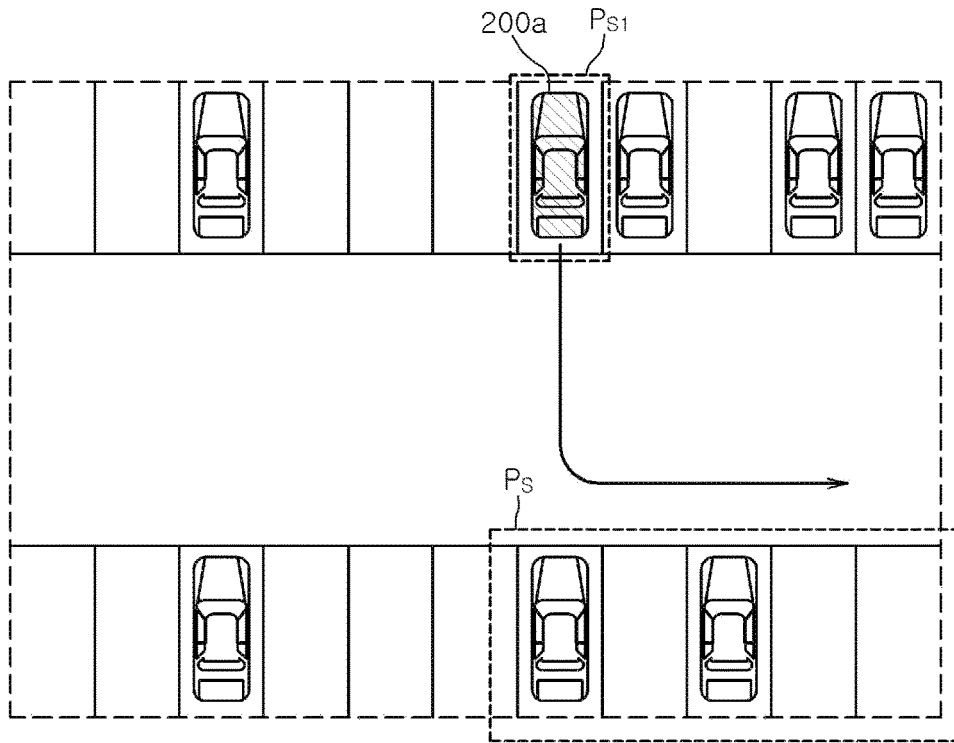

FIG. 5B

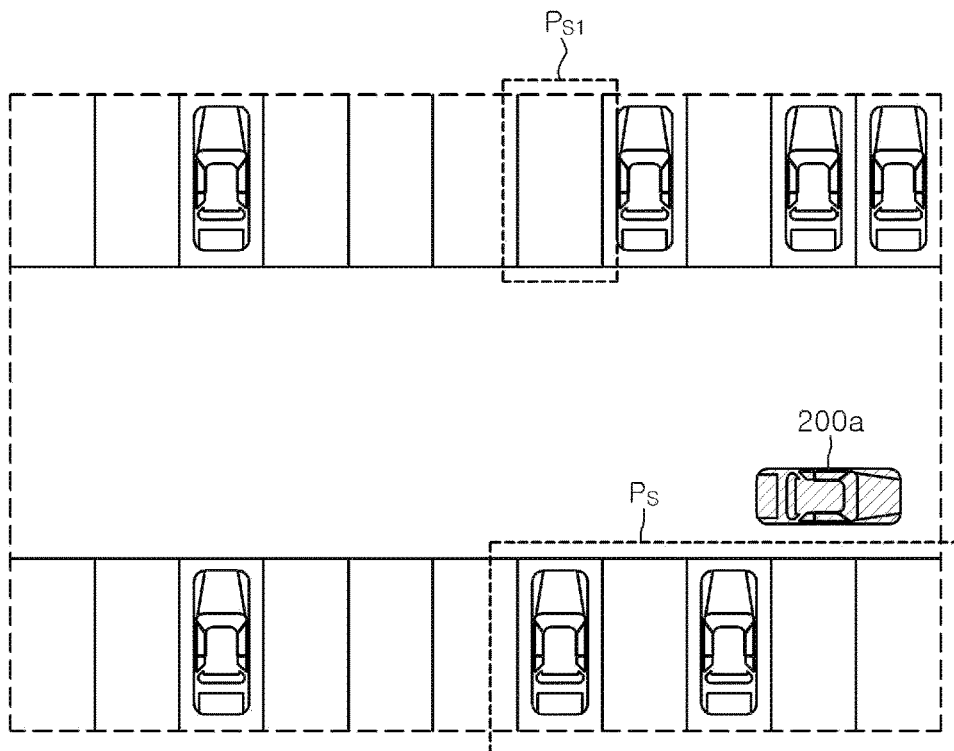

FIG. 6

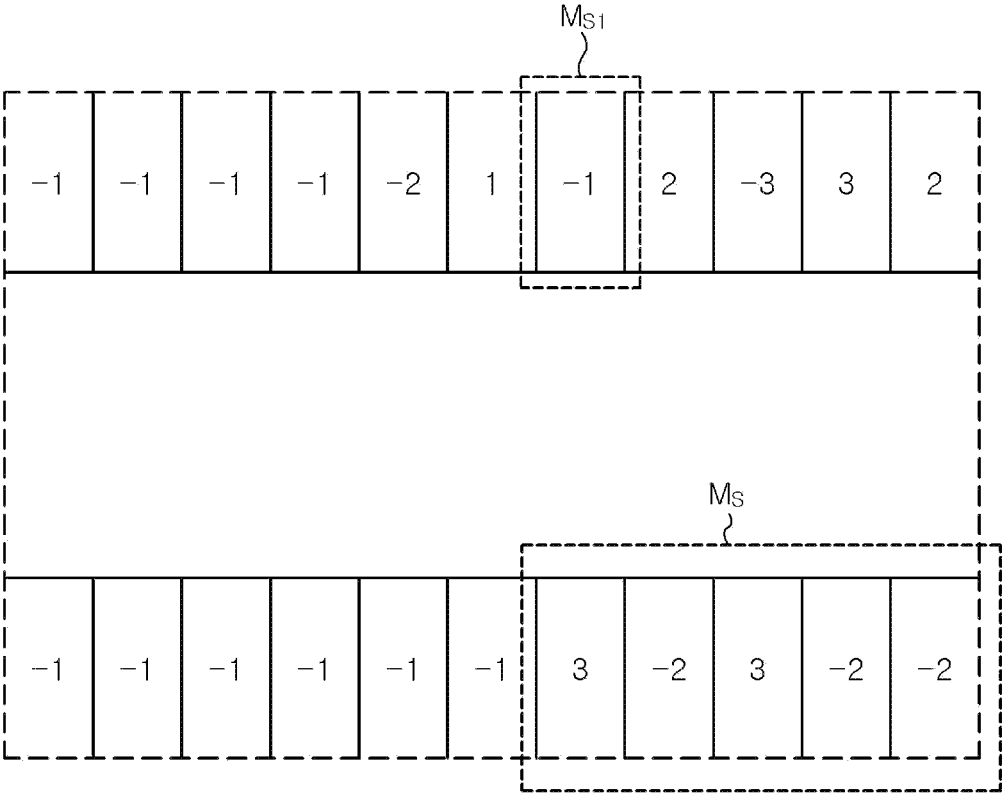

FIG. 7

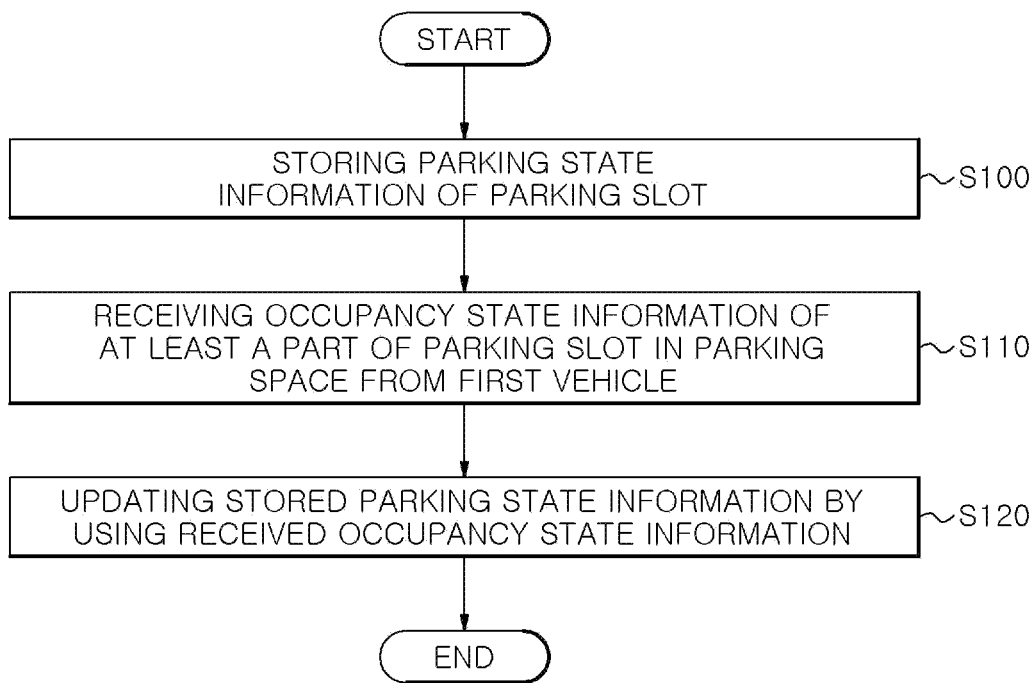
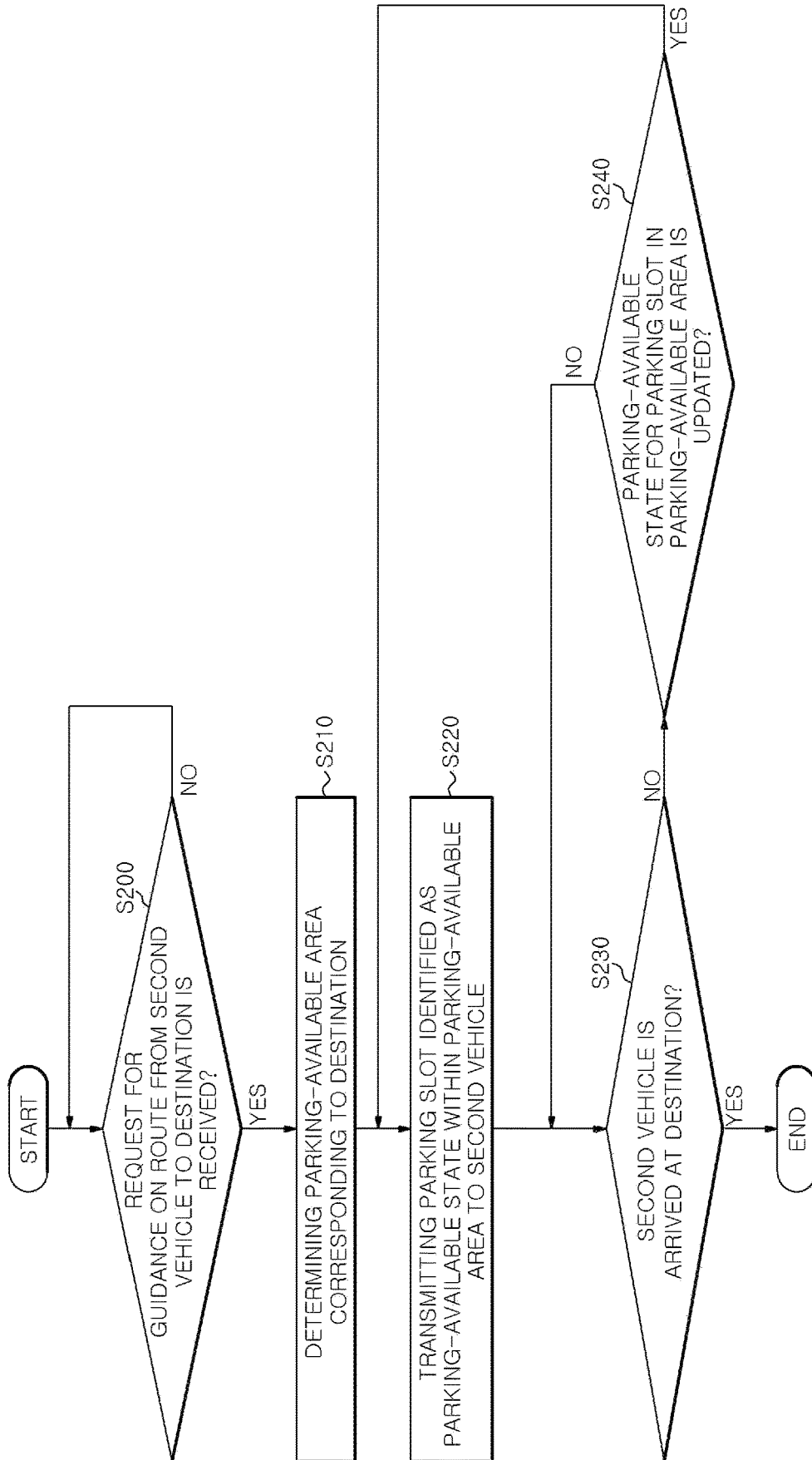

FIG. 8



PARKING GUIDANCE APPARATUS AND METHOD

CROSS-REFERENCE TO RELATED APPLICATION

This application claims priority to Korean Patent Application No. 10-2018-0057738, filed on May 21, 2018. The entire contents of the application on which the priority is based are incorporated herein by reference.

TECHNICAL FIELD

The present disclosure relates to a parking guidance apparatus and a parking guidance method for guiding a parking-available parking slot.

BACKGROUND

A vehicle is one of a transportation means capable of moving humans, objects, or animals from one location to another location while running along a road or a track. The vehicle may include a vehicle with three wheels or a vehicle with four wheels, a vehicle with two wheels such as a motorcycle, a construction machine, a motor bicycle, a bicycle, and a train running on the track, and the like.

Recently, researches on autonomous vehicles that may travel, by themselves, to a given destination by recognizing a surrounding environment and controlling the vehicles as determining a driving situation without intervention of drivers have been actively conducted.

On the other hand, the autonomous vehicles arriving at the destination may search for parking-available parking slots while traveling around the destination. At this time, since a time to search for the parking slots is an additional time required even after the vehicles arrived at the destination, it may cause inconvenience to the drivers.

SUMMARY

As described above, since a time for a vehicle arriving at a destination to search for a parking-available parking slot is required separately from an actual traveling time, convenience of a driver may be degraded. To solve the above problem, a separate sensor is provided in a specific parking space to provide parking state information to the vehicle, but cost of building facilities and maintenance are high.

Accordingly, the present disclosure provides a technology that collects occupancy state information of a parking slot through a vehicle, updates parking state information of the parking slot by using the occupancy state information, and provides a vehicle with a parking-available parking slot.

In addition, the present disclosure provides a technology for increasing an accuracy of the provided parking-available parking slot when the above-described technology is performed.

In accordance with an aspect of the present disclosure, there is provided a parking guidance apparatus comprising: a storage configured to store parking state information of a parking slot within a predetermined space; a transceiver configured to receive, from a first vehicle, occupancy state information of at least one of the parking slot in the predetermined space; and a processor configured to update the parking state information by using the received occupancy state information, and provide the second vehicle with a parking slot, which is in a parking-available state, determined on the basis of the updated parking state information

when the transceiver receives a request for a parking slot guidance for the predetermined space from a second vehicle.

In accordance with another aspect of the present disclosure, there is provided a parking guidance method performed by a vehicle, the parking guidance method comprising: obtaining first occupancy state information of a first parking slot where the vehicle parks or leaves; obtaining second occupancy state information of a second parking slot in a sensing area of the vehicle while driving; and transmitting, to a parking guidance apparatus, at least one of the first occupancy state information and the second occupancy state information, which makes the parking guidance apparatus to update parking state information of each parking slot stored in the parking guidance apparatus.

In accordance with still another aspect of the present disclosure, there is provided a non-transitory computer-readable storage medium including computer executable instructions, wherein the instructions, when executed by a processor, cause the processor to perform a parking guidance method, the method comprising: obtaining first occupancy state information of a first parking slot where the vehicle parks or leaves; obtaining second occupancy state information of a second parking slot in a sensing area while driving; and transmitting, to a parking guidance apparatus, at least one of the first occupancy state information and the second occupancy state information, which makes the parking guidance apparatus to update parking state information of each parking slot stored in the parking guidance apparatus.

A parking guidance apparatus and a parking guidance method according to one embodiment may receive occupancy state information of the parking slot from the vehicle, and thus may provide the parking-available parking slot without building a separate facility. Further, since the parking guidance apparatus and the parking guidance method receive the occupancy state information on the parking slot in a real time, and update the parking state information based on the occupancy state information, it is possible to increase an accuracy of determining the parking-available parking slot.

BRIEF DESCRIPTION OF THE DRAWINGS

FIG. 1 shows a block diagram of a parking guidance system according to one embodiment.

FIG. 2 shows a diagram illustrating a sensing area for occupancy state information around a vehicle according to one embodiment.

FIG. 3A shows a diagram illustrating a case in which a vehicle detects occupancy state information of a parking slot according to one embodiment.

FIG. 3B shows a diagram illustrating a case in which a vehicle detects occupancy state information of a parking slot according to one embodiment.

FIG. 4 shows a diagram illustrating a parking slot map in which the occupancy state information, detected by the vehicle illustrated in FIGS. 3A and 3B, is reflected.

FIG. 5A shows a diagram illustrating a case in which a vehicle detects occupancy state information of a parking slot according to another embodiment.

FIG. 5B shows a diagram illustrating a case in which a vehicle detects occupancy state information of a parking slot according to another embodiment.

FIG. 6 shows a diagram illustrating a parking slot map in which the occupancy state information, detected by the vehicle illustrated in FIGS. 5A and 5B, is reflected.

FIG. 7 shows a flowchart illustrating a method of updating parking state information performed by a parking guidance apparatus according to one embodiment.

FIG. 8 shows a flowchart illustrating a method of providing parking state information performed by a parking guidance apparatus according to another embodiment.

DETAILED DESCRIPTION

The advantages and features of the present disclosure and the methods of accomplishing these will be clearly understood from the following description taken in conjunction with the accompanying drawings. However, embodiments are not limited to those embodiments described, as embodiments may be implemented in various forms. It should be noted that the present embodiments are provided to make a full disclosure and also to allow those skilled in the art to know the full range of the embodiments. Therefore, the embodiments are to be defined only by the scope of the appended claims.

In describing the embodiments of the present disclosure, if it is determined that detailed description of related known components or functions unnecessarily obscures the gist of the present disclosure, the detailed description thereof will be omitted. Further, the terminologies to be described below are defined in consideration of functions of the embodiments of the present disclosure and may vary depending on a user's or an operator's intention or practice. Accordingly, the definition thereof may be made on a basis of the content throughout the specification.

FIG. 1 shows a block diagram of a parking guidance system according to one embodiment.

The parking guidance system **1** according to one embodiment may include a parking guidance apparatus **100** and a vehicle **200**.

The parking guidance apparatus **100** according to one embodiment may be implemented as a type of a server providing navigation information, or be provided to inter-work with the server, and may transmit and receive navigation information including parking guidance information in relation to the vehicle **200**. Herein, the navigation information may include a route from a current location of the vehicle **200** to a destination and information related thereto.

Typically, when the vehicle transmits, to the server, a request for guidance on the route to the destination, the server may provide the vehicle with at least one route to the destination from the current location of the vehicle. At this time, if a parking space for the vehicle is not provided at the destination or there is no parking-available parking slot in the parking space, the driver may park the vehicle in a parking space around the destination and then may move to the destination. If the vehicle is capable of autonomous driving, the vehicle may travel itself to the parking space around the destination.

Accordingly, the vehicle may need information on the parking space around the destination as well as the route to the destination. In order to collect the information on the parking space around the destination, the driver may directly drive the vehicle to search for the parking space and parking slots around the destination, or the vehicle capable of autonomous driving may directly search for the parking space and the parking slots around the destination. As a result, it may take an additional time to search for the parking space and the parking slots other than a driving time to the destination.

In some parking spaces, a sensor for each parking slot may be provided to provide, to the vehicle and/or to the

driver, information on the parking space, specifically, information on a parking-available parking slot in the parking space. However, this may require an additional cost of building facilities and maintenance.

To solve the above problem, the parking guidance apparatus **100** according to one embodiment may establish a database (DB) on a state of a parking slot based on occupancy state information of the parking slot detected by the vehicle **200a**, and then may provide, by using the DB, the parking slot in a parking-available state to the vehicle **200b** that requested guidance on a route to the destination.

Referring to FIG. 1, the parking guidance apparatus **100** according to one embodiment may include a storage **110** for storing parking state information of the parking slot; a transceiver **120** for communicating with the vehicle **200**; an update unit **130** for updating the parking state information stored in the storage **110**; and a control unit **140** for providing the parking slot in the parking-available state to the vehicle **200** by controlling the transceiver **120**.

In the present specification, the update unit **130** and the control unit **140** are described as components that are distinguished from each other, and are implemented as separate hardware, but are not limited thereto. That is, the update unit **130** and the control unit **140** may be implemented with one processor, and in this case, the functions of the update unit **130** and the control unit **140** may be expressed as a series of commands included in one or more programs executed by the processor.

In FIG. 1, a case in which the parking guidance apparatus **100** communicates with the vehicles **200** including a first vehicle **200a** and a second vehicle **200b** is illustrated. Herein, since the first vehicle **200a** and the second vehicle **200b** are functionally separated, there is no difference between components therein and operations thereof. In addition, the parking guidance apparatus **100** may communicate with the first vehicle **200a** and the second vehicle **200b** at a same time or at a different time. Herein, the communicating at the different time may include communicating with a specific vehicle as the first vehicle **200a** to perform a first function and then communicating with the same specific vehicle as the second vehicle **200b** to perform a second function.

The transceiver **120** may exchange information by communicating with the vehicle **200** in various publicly known communication methods. The transceiver **120** according to one embodiment may communicate with the vehicle **200** through a base station by adopting a publicly known communication method such as CDMA, GSM, W-CDMA, TD-SCDMA, WiBro, LTE, EPC, and the like. Alternatively, the transceiver **120** according to another embodiment may communicate with the vehicle **200** within a predetermined distance by adopting a communication method such as a wireless LAN, Wi-Fi, Bluetooth, Zigbee, Wi-Fi Direct (WFD), Ultra-Wide Band (UWB), Infrared Data Association (IrDA), Bluetooth Low Energy (BLE), and Near Field Communication (NFC), and the like. However, a method in which the transceiver **120** communicates with the vehicle **200** is not limited to the embodiments described above.

The transceiver **120** may receive occupancy state information of the parking slot detected by the vehicle **200**. Herein, the occupancy state information may indicate information on whether the parking slot is occupied by the vehicle **200**, that is, whether the vehicle **200** is in a parked state.

In order to detect the occupancy state information, the vehicles **200** may include sensing devices **250a** and **250b**.

Hereinafter, the sensing devices **250a** and **250b** included in the vehicles **200** will be described in detail with reference to FIG. 2.

FIG. 2 shows a diagram illustrating a sensing area for occupancy state information around the vehicle **200** according to one embodiment.

As described above, the vehicles **200** may detect occupancy state information of a parking slot by using the sensing devices **250a** and **250b**. To this end, the sensing devices **250a** and **250b** of the vehicles **200** according to one embodiment may include at least one of a camera, radar, LiDAR, and an ultrasonic sensor.

The camera may be provided to face forward, sideways, and/or rearward from the vehicle **200**, and may capture an image in a corresponding direction. The captured image may be a basis for obtaining information such as a traffic lane or a road sign, as well as an object around the vehicle **200** through image processing. Finally, the captured image may be used to implement a Lane Departure Warning System (LDWS), a Lane Keeping Assist System (LKAS), an Auto Emergency Braking (AEB) system, and the like. In FIG. 2, it may be seen that a sensing area detected by the camera according to one embodiment is illustrated as Sc.

The radar may be provided to face forward, sideways, and/or rearward from the vehicle **200**, and may emit a pulse in a corresponding direction and receive an echo pulse reflected from an object positioned in the corresponding direction. The received echo pulse may include information not only on existence of the object in the emitting direction of the pulse, but also on a distance to and shape of the object in the corresponding direction. The echo pulse may be used to implement an Adaptive Cruise Control (ACC) system, a Blind Spot Information System (BLIS), and the like. In FIG. 2, it may be seen that a sensing area detected by the radar according to one embodiment is illustrated as SR.

The LiDAR may be provided to face forward, sideways, and/or rearward from the vehicle **200**, and may emit a laser in a corresponding direction and receive an echo laser reflected from an object positioned in the corresponding direction. The received echo laser may include information not only on existence of the object in the emitting direction of the laser, but also on a distance to and shape of the object in the corresponding direction. The echo laser may be used to implement a Forward Collision Warning (FCW) system, the AEB system, and the like. In FIG. 2, it may be seen that a sensing area detected by the LiDAR according to one embodiment is illustrated as S_L.

The ultrasonic sensor may be provided to face forward, sideways, and/or rearward from the vehicle **200**, and may emit an ultrasonic wave in a corresponding direction and receive an echo ultrasonic wave reflected from an object positioned in the corresponding direction. The received echo ultrasonic wave may include information not only on existence of the object in the emitting direction of the ultrasonic wave, but also on a distance to and shape of the object in the corresponding direction. The echo ultrasonic wave may be used to implement a Parking Assist System (PAS), and the like. In FIG. 2, it may be seen that a sensing area detected by the ultrasonic sensor according to one embodiment is illustrated as S_U.

Further, the vehicle **200** according to one embodiment may store, in advance, a high definition map to use. Herein, the high definition map may indicate a map that has high accuracy for control over the vehicle **200**, and may include information not only on a position on the plane of the road but also on an altitude, slope, curvature, the traffic lane, and the like. The high definition map may further include

information on road facilities such as traffic regulation signs, traffic lights, and the like. In addition, the high definition map may further include information on a parking slot in a parking space.

Accordingly, the vehicles **200** including the above-described sensing devices **250a** and **250b** may identify a location of the vehicle **200** on the high definition map while traveling in the parking space, and then may detect the occupancy state information of the parking slot within the sensing area from the identified location.

Referring to FIG. 1 again, the transceiver **120** may receive the occupancy state information of the parking slot detected by at least one vehicle **200**, and in particular, may receive the occupancy state information of separate parking slots from a plurality of the vehicles **200**.

The storage **110** may store the parking state information of the parking slot, and the update unit **130** may update the parking state information stored in the storage **110** by using the occupancy state information of the parking slot received through the transceiver **120**.

Specifically, the storage **110** may store identification information on a plurality of parking spaces existing in an entire area in which a service is provided and a plurality of parking slots therein, together with the parking state information of each of the plurality of the parking slots. Herein, the parking state information is information for determining whether the parking slot is in the parking-available state, which will be described later.

Further, the storage **110** may store location information of the parking slot into the identification information of each of the plurality of the parking slots.

The storage **110** may list and store the plurality of the parking slots by the parking space, or store the plurality of the parking slots on a parking slot map. Herein, the parking slot map is a map in which the location information of the parking slots is visually displayed, and may share a coordinate system with the high definition map stored in the first vehicle **200a**. Hereinafter, it will be described on the assumption that the storage **110** stores the parking state information on the parking slot map.

The update unit **130** may update the parking state information of each parking slot stored in the storage **110** by using the occupancy state information received through the transceiver **120**.

Hereinafter, a method of updating the parking state information of the parking slot will be described in detail with reference to FIGS. 3A, 3B, 4, 5A, 5B, and 6.

FIGS. 3A and 3B show diagrams illustrating a case in which the first vehicle **200a** detects occupancy state information of a parking slot according to one embodiment, and FIG. 4 shows a diagram illustrating a parking slot map in which the occupancy state information, detected by the first vehicle **200a** illustrated in FIGS. 3a and 3b, is reflected.

FIG. 3A shows a case in which the first vehicle **200a** entering a parking space travels in a direction of an arrow to complete parking in a first parking slot P_{S1}. In this case, parking slots positioned on a right side of the first vehicle **200a** traveling in the direction of the arrow may fall within a sensing area of the first vehicle **200a**. Therefore, the first vehicle **200a** may detect occupancy state information of second parking slots P_S in the sensing area of the first vehicle **200a** until completing the parking in the first parking slot P_{S1}.

FIG. 3B shows a case in which the first vehicle **200a** illustrated in FIG. 3A completes the parking in the first parking slot P_{S1}. The first vehicle **200a** having completed the parking may transmit, to the transceiver **120** of the parking

guidance apparatus 100, the occupancy state information of the first parking slot P_{S1} in which the first vehicle 200a occupied and the second parking slots P_S detected until completing the parking.

When the occupancy state information is received by the transceiver 120, the update unit 130 may update parking state information stored in the storage 110 by using the received occupancy state information. Referring to FIG. 4, the parking slot map stored in the storage 110 may be provided to correspond to the parking slots on a high definition map stored in the first vehicle 200a. Accordingly, the update unit 130 may identify, on the parking slot map, an area corresponding to the parking slot having the received occupancy state information, and may update the parking state information displayed in the identified area.

Specifically, the update unit 130 may update the parking state information by dividing the received occupancy state information of the parking slots into the occupancy state information of the first parking slot P_{S1} and the occupancy state information of the second parking slots P_S .

If the occupancy state information of the first parking slot P_{S1} is received, the update unit 130 may first identify an area M_{S1} , which is an area, on the parking slot map, corresponding to the first parking slot P_{S1} . Then, since the first parking slot P_{S1} is in an occupancy state, the update unit 130 may initialize the parking state information of the area M_{S1} on the parking slot map to one corresponding to the occupancy state.

Alternatively, in a case of the second parking slots P_S among the plurality of the parking slots of which the occupancy state information is received, the update unit 130 may first identify an area M_S , on the parking slot map, corresponding to the plurality of the parking slots of which the occupancy state information is received. Then, the update unit 130 may accumulate the received occupancy state information in the area M_S , on the parking slot map, corresponding to the second parking slots P_S according to the occupancy state information of each of the second parking slots P_S . Specifically, if the occupancy state information of any one of the second parking slots P_S shows the occupancy state, the update unit 130 may add one to the parking state information of the corresponding parking slot. On the other hand, if the occupancy state information of another parking slot among the second parking slots P_S shows an inoccupancy state, the update unit 130 may subtract one from the parking state information of the corresponding parking slot.

In other words, the update unit 130 may calculate, for each of the second parking slots P_S , a difference between the number of the accumulated occupancy states and the number of the accumulated inoccupancy states from a time when the parking state information is initialized, and then may reflect the difference to an initial value to update the parking state information of the corresponding parking slot. For example, if the number of the accumulated occupancy states of any one second parking slot which is initialized to the initial value of one is four and the number of the accumulated inoccupancy states thereof is two, the update unit 130 may update the parking state information of the corresponding parking slot to three which is determined by adding two which is a difference between the accumulated occupancy states of four and the accumulated inoccupancy states of two to the initial value of one. On the other hand, if the number of the accumulated occupancy states of any one second parking slot which is initialized to the initial value of one is two and the number of the accumulated inoccupancy states is four, the update unit 130 may update the parking state

information of the corresponding parking slot to minus one which is determined by subtracting two which is a difference between the accumulated occupancy states of two and the accumulated inoccupancy states of four from the initial value of one.

As described above, the parking state information of the second parking slots P_S may be determined based on the initial value, the number of the occupancy states and the number of the inoccupancy states accumulated from the received occupancy state information.

FIGS. 3A, 3B, and 4 illustrate the case in which the first vehicle 200a parks in the first parking slot P_{S1} . Hereinafter, a case in which the first vehicle 200a leaves the first parking slot P_{S1} will be described.

FIGS. 5A and 5B show diagrams illustrating a case in which the first vehicle 200a detects occupancy state information of a parking slot according to another embodiment, FIG. 6 shows a diagram illustrating a parking slot map in which the occupancy state information, detected by the first vehicle 200a illustrated in FIGS. 5A and 5B, is reflected.

FIG. 5A shows a case in which the first vehicle 200a, which has completed parking in the first parking slot P_{S1} , travels in a direction of an arrow to leave the first parking slot P_{S1} . In this case, parking slots positioned on a right side of the first vehicle 200a traveling in the direction of the arrow may fall within a sensing area of the first vehicle 200a. Therefore, the first vehicle 200a may detect occupancy state information of second parking slots P_S until the first vehicle 200a exits a parking space after leaving the first parking slot P_{S1} .

FIG. 5B shows a case in which the first vehicle 200a, illustrated in FIG. 5A, which left the first parking slot P_{S1} travels in the parking space. The first vehicle 200a which has completed leaving the parking slot P_{S1} , may transmit, to the transceiver 120 of the parking guidance apparatus 100, the occupancy state information of the first parking slot P_{S1} in which the first vehicle 200a left and the second parking slots P_S detected while traveling the parking space.

When the occupancy state information is received by the transceiver 120, the update unit 130 may update parking state information stored in the storage 110 by using the received occupancy state information.

Referring to FIG. 6, the update unit 130 may update the parking state information by dividing the received occupancy state information of the parking slots into the occupancy state information of the first parking slot P_{S1} and the occupancy state information of the second parking slots P_S other than the first parking slot P_{S1} .

When the occupancy state information of the first parking slot P_{S1} is received, the update unit 130 may first identify an area M_{S1} , which is an area, on the parking slot map, corresponding to the first parking slot P_{S1} . Then, since the first parking slot P_{S1} is in an inoccupancy state, the update unit 130 may initialize the parking state information of the area M_{S1} on the parking slot map to minus one corresponding to the inoccupancy state.

Alternatively, in a case of the second parking slots P_S among the plurality of the parking slots of which the occupancy state information is received, the update unit 130 may first identify an area M_S , on the parking slot map, corresponding to the second parking slots P_S . Then, the update unit 130 may accumulate the received occupancy state information in the area M_S , on the parking slot map, corresponding to the second parking slots P_S according to the occupancy state information of each of the second parking slots P_S .

Specifically, if the occupancy state information of any one of the second parking slots P_S shows an occupancy state, the update unit **130** may add one to the parking state information of the corresponding parking slot. On the other hand, if the occupancy state information of another parking slot among the second parking slots P_S shows the inoccupancy state, the update unit **130** may subtract one from the parking state information of the corresponding parking slot.

As described referring to FIGS. 3A, 3B, and 4, the update unit **130** may calculate, for each of the second parking slots P_S , a difference between the number of the accumulated occupancy states and the number of the inoccupancy states from a time when the parking state information is initialized, and then may reflect the difference to an initial value to update the parking state information of the corresponding parking slot. For example, if the number of the accumulated occupancy states of any one of the second parking slots P_S which is initialized to the initial value of minus one is two and the number of the accumulated inoccupancy states thereof is four, the update unit **130** may update the parking state information of the corresponding parking slot to minus three which is determined by subtracting two which is a difference between the accumulated occupancy states of two and the accumulated inoccupancy states of four from the initial value of minus one. On the other hand, if the number of the accumulated occupancy states of any one of the second parking slots P_S which is initialized to the initial value of minus one is four and the number of the accumulated inoccupancy states is two, the update unit **130** may update the parking state information of the corresponding parking slot to one which is determined by adding two which is a difference between the accumulated occupancy states of four and the accumulated inoccupancy states of two to the initial value of minus one.

As described above, the parking state information of the second parking slots P_S may be determined based on the initial value, the number of the occupancy states and the number of the inoccupancy states accumulated from the received occupancy state information.

Referring to FIG. 1 again, when the control unit **140** identifies the second vehicle **200b** that tries to park in a parking space through the transceiver **120**, the control unit **140** may provide a parking-available parking slot determined based on the updated parking state information. Herein, the parking space in which the second vehicle **200b** tries to park may indicate a parking space within a predetermined range from a destination of the second vehicle **200b**. When the transceiver **120** receives a request for guidance on a route to the destination from the second vehicle **200b**, the control unit **140** may determine a parking space within the predetermined range from the destination. Alternatively, when the transceiver **120** receives a request for guidance on a parking slot from the second vehicle **200b**, the control unit **140** may determine a parking space within the predetermined range from a current location of the second vehicle **200b** or the destination of the second vehicle **200b**.

Then, the control unit **140** may determine a parking slot in a parking-available state based on the updated parking state information. For example, the control unit **140** may determine a state of the corresponding parking slot by comparing the updated parking state information with a predetermined reference value. If the reference value is minus one, the control unit **140** may determine a state of a parking slot having parking state information of minus one or less as the parking-available state. On the other hand, the

control unit **140** may determine a state of a parking slot having parking state information exceeding minus one as a parking-unavailable state.

As described above, since the parking-available state of the parking slot is determined based on accumulated data, an accuracy of determination of the parking-available state may be improved.

Finally, the control unit **140** may provide the parking slot in the parking-available state to the second vehicle **200b**. Herein, there may be one or a plurality of parking slots in the parking-available state provided to the second vehicle **200b**, and if there are the plurality of the parking slots in the parking-available state, the second vehicle **200b** may determine any one of the plurality of the parking slots as a final parking slot.

Heretofore, the first vehicle **200a** transmitting the occupancy state information and the second vehicle **200b** receiving the parking slot in the parking-available state are described as separate vehicles, however, the first vehicle **200a** and the second vehicle **200b** may be the identical vehicle.

Hereinafter, the second vehicle **200b** that has received the plurality of the parking slots in the parking-available state will be described.

Referring to FIG. 1, the second vehicle **200b** according to one embodiment may receive a plurality of parking slots in a parking-available state, and may determine any one of the plurality of the parking slots in the parking-available state as a final parking slot, and then may complete parking in the final parking slot.

To this end, the second vehicle **200b** according to one embodiment may include a transceiver **220b** for receiving the plurality of the parking slots in the parking-available state from the parking guidance apparatus **100**; and a control unit **240b** for determining the final parking slot among the plurality of the received parking slots.

The transceiver **220b** may receive the plurality of the parking slots, in the parking-available state, of a specific parking space from the parking guidance apparatus **100**. Herein, the specific parking space may indicate a parking space within the predetermined range from the destination of the second vehicle **200b**.

After receiving the plurality of the parking slots, the control unit **240b** may generate a route from the destination to each of the plurality of the parking slots, and may obtain traveling times according to the generated routes. In this case, the control unit **240b** may obtain the traveling time according to each of the routes by reflecting current traffic information.

Then, the control unit **240b** may determine a parking slot having a shortest traveling time to the destination among the plurality of the parking slots as the final parking slot. Accordingly, it is possible to shorten a traveling time between the destination and the parking slot.

In addition, the control unit **240b** may determine the final parking slot after arriving at the destination by considering changes in a traffic environment while traveling to the destination. To this end, the transceiver **220b** may receive a plurality of a parking slots in the parking-available state updated by the parking guidance apparatus **100** until the second vehicle **200b** arrives at the destination.

On the other hand, the second vehicle **200b** may change the final parking slot according to the traveling time from the final parking section to the destination even after completing parking in the final parking slot. Specifically, after completing the parking, the control unit **240b** of the second vehicle **200b** may identify whether the traveling time from the final

parking slot to the destination is greater than or equal to a threshold value. Herein, the threshold value may indicate a minimum traveling time in which the final parking slot needs to be changed.

If the traveling time from the final parking slot to the destination is greater than or equal to the threshold value, the control unit **240b** may receive a plurality of updated parking slots in the parking-available state from the parking guidance apparatus **100** through the transceiver **220b**. Thereafter, the control unit **240b** may generate a route to the destination from each of the plurality of the received parking slots, and may determine a parking slot of a route having a shortest traveling time among the generated routes as the final parking slot to travel and park.

Accordingly, it is possible to shorten the traveling time between the destination and the parking slot.

Hereinafter, a method of updating the parking state information and a method of providing the parking state information performed by the parking guidance apparatus **100** illustrated in FIG. **1** will be described.

FIG. **7** shows a flowchart illustrating a method of updating parking state information as a method controlled by the parking guidance apparatus **100** according to one embodiment.

First, in a step **S100**, the parking guidance apparatus **100** may store parking state information of a parking slot. Herein, the parking state information may indicate information for determining a parking-available state, and may be numerical information.

Next, in a step **S110**, the parking guidance apparatus **100** may receive occupancy state information of at least a part of a parking slot in a parking space from the first vehicle **200a**. Herein, the occupancy state information may include an occupancy state in which the parking slot is occupied by a vehicle, and an inoccupancy state that is not occupied by a vehicle.

In a step **S120**, when the occupancy state information is received, the parking guidance apparatus **100** may update the stored parking state information by using the received occupancy state information. Specifically, the parking guidance apparatus **100** may update the parking state information by dividing the received occupancy state information into the occupancy state information of the first parking slot P_{S1} where the first vehicle **200a** parks or leaves, and the occupancy state information of the second parking slots P_S in which the first vehicle **200a** detects around the first parking slot P_{S1} .

When the occupancy state information of the first parking slot P_{S1} is received, the parking guidance apparatus **100** may initialize the parking state information of the first parking slot P_{S1} to parking state information corresponding to the occupancy state information. For example, if the parking state information of the first parking slot P_{S1} is three and the first parking slot P_{S1} is in the inoccupancy state, the parking guidance apparatus **100** may initialize the parking state information of the first parking slot P_{S1} to minus one corresponding to the inoccupancy state.

On the other hand, when the occupancy state information of the second parking slots P_S is received, the parking guidance apparatus **100** may update the parking state information of the second parking slots P_S based on the number of the occupancy states and the number of the inoccupancy states accumulated from the received occupancy state information of the second parking slots P_S . Specifically, the parking guidance apparatus **100** may update the parking state information by adding one as much as the number of the occupancy states to the initialized parking state infor-

mation of the second parking slots P_S and subtracting one as much as the number of the inoccupancy states from the initialized parking state information of the second parking slots P_S .

FIG. **8** shows a flowchart illustrating a method of providing parking state information as a method controlled by the parking guidance apparatus **100** according to another embodiment.

First, in a step **S200**, the parking guidance apparatus **100** may identify whether a request for guidance on a route from the second vehicle **200b** to a destination has been received. If the request for the guidance on the route is not received, the parking guidance apparatus **100** may repeatedly identify whether the request has been received.

On the other hand, if the request for the guidance on the route is received, in a step **S210**, the parking guidance apparatus **100** may determine a parking-available area corresponding to the destination. Herein, the parking-available area may indicate an area determined within a predetermined range from the destination.

Then, in a step **S220**, the parking guidance apparatus **100** may transmit a parking slot identified as a parking-available state within the parking-available area to the second vehicle **200b**. To this end, the parking guidance apparatus **100** may compare updated parking state information with a reference value.

After transmitting the parking slot in the parking-available state to the second vehicle **200b**, in a step **S230**, the parking guidance apparatus **100** may identify whether the second vehicle **200b** has arrived at the destination. If the second vehicle **200b** arrives at the destination, the process ends.

On the other hand, if the second vehicle **200b** has not reached the destination, in a step **S240**, the parking guidance apparatus **100** may identify whether the parking-available state for the parking slot in the parking-available area is updated. If the parking-available state is not updated, the step **S240** may proceed to the step **S230**.

Alternatively, if the parking-available state is updated, the step **S240** may proceed to the step **S220** so that the parking guidance apparatus **100** may transmit a parking slot identified as the updated parking-available state to the second vehicle **200b**.

On the other hand, each of the steps included in the parking guidance method according to one embodiment described above may be implemented in a computer-readable recording medium for storing a computer program programmed to perform each of the steps.

According to one embodiment, the above-described parking guidance apparatus and method may be used in various fields such as a home or an industrial site, and thus may have industrial applicability.

As described above, those skilled in the art will understand that the present disclosure can be implemented in other forms without changing the technical idea or essential features thereof. Therefore, it should be understood that the above-described embodiments are merely examples, and are not intended to limit the present disclosure. The scope of the present disclosure is defined by the accompanying claims rather than the detailed description, and the meaning and scope of the claims and all changes and modifications derived from the equivalents thereof should be interpreted as being included in the scope of the present disclosure.

What is claimed is:

1. A parking guidance apparatus comprising:
 - a storage configured to store parking state information of a parking slot within a predetermined space;

a transceiver configured to receive, from a first vehicle, occupancy state information of at least one of the parking slot in the predetermined space; and
 a processor configured to update the parking state information by using the received occupancy state information, and provide a second vehicle with a parking slot, which is in a parking-available state, determined based the updated parking state information when the transceiver receives a request for a parking slot guidance for the predetermined space from a second vehicle,
 wherein the transceiver is further configured to receive occupancy state information of a first parking slot where the first vehicle parks or leaves and occupancy state information of a second parking slot where the first vehicle detects near the first parking slot,
 wherein the processor is further configured to update, when the transceiver receives the occupancy state information of the second parking slot, the parking state information of the second parking slot by using a difference between the accumulated number of the occupancy states and the accumulated number of the inoccupancy states of the second parking slot from a time when the parking state information of the second parking slot is initialized, and
 wherein the processor is further configured to determine whether the second parking slot is in a parking-available state based on the difference between the accumulated number of the occupancy states and the accumulated number of the inoccupancy states of the second parking slot.

2. The parking guidance apparatus of claim 1, wherein the processor is further configured to initialize, when the transceiver receives the occupancy state information of the first parking slot, parking state information of the first parking slot to parking state information corresponding to the received occupancy state information of the first parking slot.

3. The parking guidance apparatus of claim 1, wherein the processor is further configured to provide, to the second vehicle, a parking slot in a parking-available state determined based on the updated parking state information if the predetermined space is located within a predetermined range from a destination of the second vehicle.

4. A parking guidance method performed by a vehicle, the parking guidance method comprising:
 obtaining first occupancy state information of a first parking slot where the vehicle parks or leaves;
 obtaining second occupancy state information of a second parking slot sensed by the vehicle while driving to or from the first parking slot;
 transmitting, to a parking guidance apparatus, at least one of the first occupancy state information and the second occupancy state information, causing the parking guidance apparatus to update parking state information of each parking slot stored in the parking guidance apparatus;
 transmitting, to the parking guidance apparatus, a request for guidance on parking for a destination;
 receiving, from the parking guidance apparatus, parking-available states on a plurality of parking slots in a parking space corresponding to the destination;
 generating first routes from the destination to each of a subset of parking slots in the parking-available states; and
 determining a final parking slot according to traveling times of the generated first routes.

5. The parking guidance method of claim 4, wherein the vehicle comprises a sensing device including at least one of a radar, a LiDAR, a camera, and an ultrasonic sensor, and wherein the obtaining the second occupancy state information is obtaining the second occupancy state information of the second parking slot within the sensing area of the sensing device.

6. The parking guidance method of claim 4 further comprising:
 receiving, from the parking guidance apparatus, a plurality of parking slots in the parking-available states updated after completing parking if a traveling time from the determined final parking slot to the destination is greater than or equal to a threshold value after completing the parking.

7. The parking guidance method of claim 6, further comprising:
 generating a second route from each of the plurality of the updated parking slots to the destination; and
 changing the final parking slot based on a traveling time according to the second routes.

8. A non-transitory computer-readable storage medium including computer executable instructions, wherein the instructions, when executed by a processor, cause the processor to perform a parking guidance method, the method comprising:
 obtaining first occupancy state information of a first parking slot where a vehicle parks or leaves;
 obtaining second occupancy state information of a second parking slot sensed by the vehicle while driving to or from the first parking slot;
 transmitting, to a parking guidance apparatus, at least one of the first occupancy state information and the second occupancy state information, causing the parking guidance apparatus to update parking state information of each parking slot stored in the parking guidance apparatus;
 transmitting, to the parking guidance apparatus, a request for guidance on parking for a destination;
 receiving, from the parking guidance apparatus, parking-available states on a plurality of parking slots in a parking space corresponding to the destination;
 generating first routes from the destination to each of a subset of parking slots in the parking-available states; and
 determining a final parking slot according to traveling times of the generated first routes.

9. The non-transitory computer-readable recording medium of claim 8, wherein the second occupancy state information of the second parking slot is obtained by at least one of a radar, a LiDAR, a camera, and an ultrasonic sensor included in the vehicle.

10. The non-transitory computer-readable recording medium of claim 8, the method further comprising:
 receiving, from the parking guidance apparatus, a plurality of parking slots in the parking-available states updated after completing parking if a traveling time from the determined final parking slot to the destination is greater than or equal to a threshold value after completing the parking.

11. The non-transitory computer-readable recording medium of claim 10, the method further comprising:
 generating a second route from each of the plurality of the updated parking slots to the destination; and

changing the final parking slot based on a traveling time
according to the generated second routes.

* * * * *