

June 7, 1955

E. A. DOLAN, SR
VARIABLE LIGHT TORCH
Filed Feb. 4, 1953

2,710,395

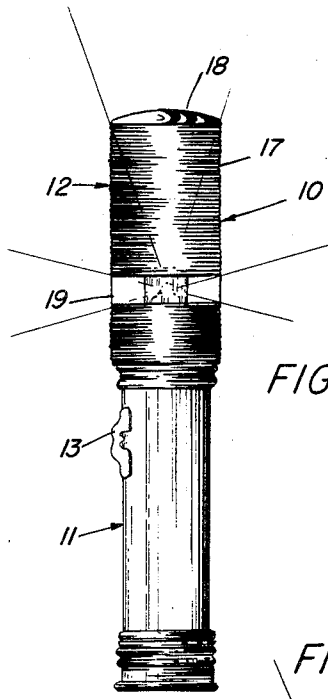

FIG. 1

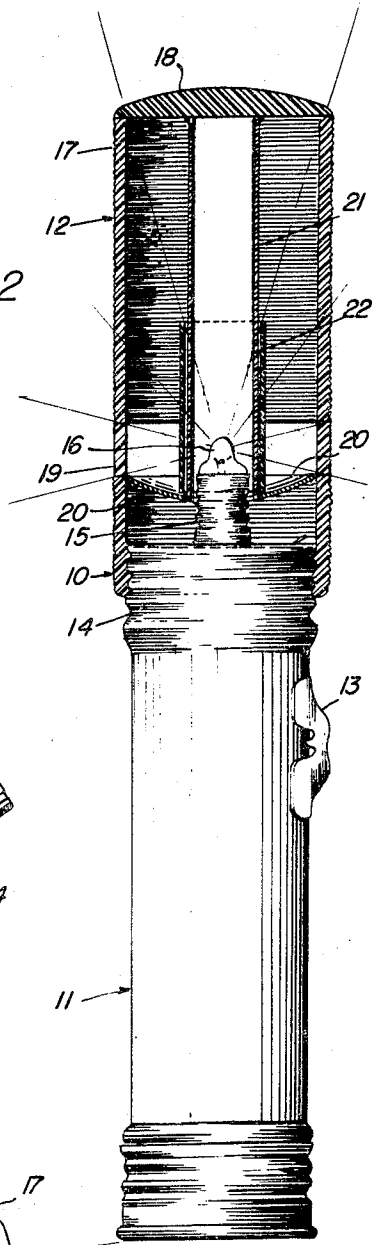

FIG. 2

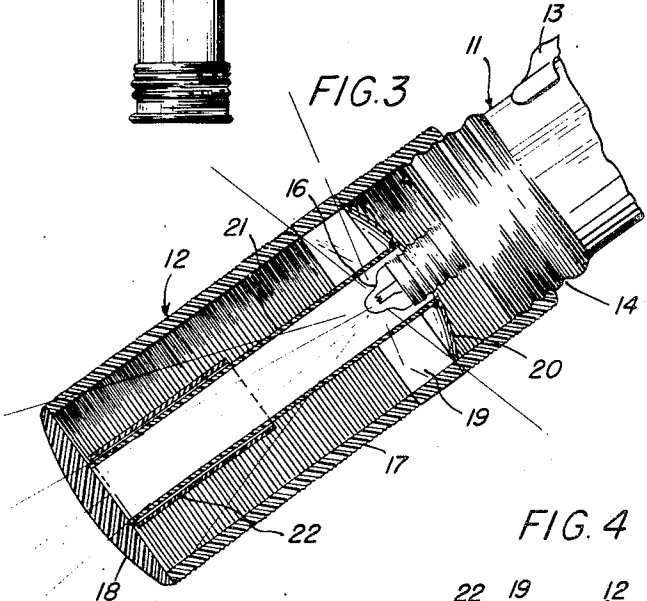

FIG. 3

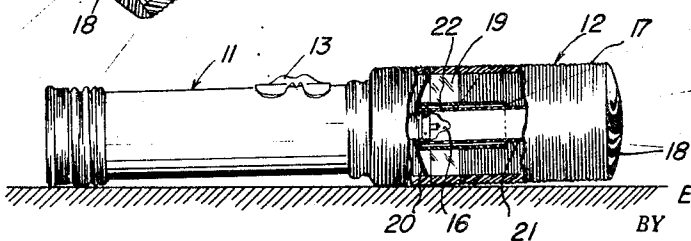

FIG. 4

INVENTOR.
Edward A. Dolan, Sr.

BY
Jucker & Jucker
Agents

1

2,710,395

VARIABLE LIGHT TORCH

Edward A. Dolan, Sr., Elizabeth, N. J.

Application February 4, 1953, Serial No. 335,140

8 Claims. (Cl. 340—321)

This invention relates to a variable light torch, and more particularly such a torch from which the visible radiation may be automatically varied at will. The invention is especially useful in its application to a hand-operated electric flashlight, to which use, however, it is not restricted.

In signaling with a light at night, it is possible to communicate intelligence or directions to a single location by means of a light of unvarying intensity and color. Such signaling may be effected by suitably interrupting the visible radiation of the light, or by varying the position of the light or the direction of a beam thrown by the light source. Where intelligence is to be communicated by such light simultaneously to a number of separate localities, and particularly where different signals are to be given simultaneously to a number of separated locations, considerable confusion is likely to result. Anyone who has done much night driving has experienced confusion at unlighted or poorly-lighted intersections where a flashlight has been employed to control traffic. Like confusion is often experienced where an ordinary flashlight is employed at the scene of an accident or a breakdown on a dark road.

Furthermore, where a variable light torch has been designed in the past to show selected colors for giving different signals in different directions, as showing red in one direction and green or white in directions at right angles to that of the red showing, a complication of switches or colored light bulbs has been necessary resulting in a complex and difficultly-operated torch. Apparatus of this character is not easily or quickly operated, is easily damaged and presents exacting maintenance problems.

The present invention provides a simple, inexpensive and easily operated variable light torch having few parts and being rugged and easily maintained. After even casual use its operation becomes almost instinctive with the user, and there is no occasion to remember which operating element must be moved and in which direction such movement must take place.

According to the present invention, the variable light torch provides a light source which may be switched on or off in the usual manner, and a plurality of screens are provided for selective movement to clear or surround the light source and thereby vary the visible radiation therefrom. Variation of the visible radiation from the light source is effected by gravity and the position of the torch determines selectively the visible radiation from the light source. Preferably, a frosted envelope surrounds the light source and diffuses the light therefrom, so that the lighted torch itself is illuminated as a unit and may be used to communicate the desired signal. Finally a lens or bull's-eye serves to project a selected visible radiation which may be different from that which illuminates the frosted envelope, thereby making possible different radiations in different directions from the same torch.

2

The invention is shown by way of illustration in the accompanying drawings in which—

Fig. 1 is an elevation of a variable light torch constructed and arranged according to the invention, the torch being shown as pointed upwardly;

Fig. 2 is an elevation of the torch illustrated in Fig. 1, shown on a larger scale, parts of said torch being shown in vertical mid-section;

Fig. 3 is a broken elevation of the torch as shown in Fig. 2, the torch turned downwardly at an angle to displace a movable part therein; and

Fig. 4 is an elevation of the torch shown in Fig. 1, shown on the same scale as Fig. 1, illustrated as lying upon a plane surface, parts of the torch being broken away and shown in section to illustrate the position of certain internal elements thereof.

In the embodiment of the invention which is illustrated in the drawings, there is shown a variable light torch 10 comprising a flashlight 11 and a novel combination of elements 12 carried at the forward or light-producing end of the flashlight. As will be apparent, the torch 10 may be carried and manipulated by the hand of the user.

The flashlight 11 is of usual construction. It has the conventional switch control member 13 slidable upon its exterior surface, and is externally threaded at its forward or light-producing end, as at 14, to accommodate the ordinary lens- and reflector-carrying cap. The standard internally-threaded nipple 15 projects axially from the end of the flashlight 11 beyond the threads 14 to receive the bulb 16 of the flashlight. Thus, the bulb 16 constitutes the light source of the apparatus.

The novel combination of elements 12 will now be described.

A protective envelope 17 is provided to surround the light source or bulb 16. As here shown the protective envelope 17 is a cylindrical member screwed onto the threads 14 at the forward end of the flashlight 11. The envelope is generally translucent, and is preferably frosted. In the embodiment illustrated, the cylindrical envelope is provided with annular ribbing, which constitutes the frosting. The purpose of frosting the envelope is to permit it to diffuse the light within it rather than transmitting such light directly. Furthermore, the annular ribbing of the envelope 17 causes the light from the bulb 16 to run along the envelope, so that the entire envelope is illuminated and diffuses light outwardly from its surface all along its length.

The outer end of the envelope is closed by having a lens 18 cemented thereto. Thus, light within the envelope is diffused radially therefrom and is projected directly through the lens 18 at its end. The lens 18 may be formed as a bull's-eye, that is to say a red transparent element through which a beam having its color may be projected directly.

It is preferred to provide an unfrosted substantially transparent annular band 19 of the envelope immediately surrounding the light source or bulb 16. Accordingly, visible radiation from the light source may be transmitted directly through the lens or bull's-eye 18 and through the substantially transparent annular band 19 while being diffused through the remaining portions of the envelope 17. A reflector 20 is shown as cemented in the envelope 17 surrounding the internally threaded nipple 15 in a position to reflect the light of the bulb 16 through the lens or bull's-eye 18. This reflector may be similar to the reflector originally associated with the flashlight 11; and it may, in fact, be the same reflector removed from the lens- and reflector-carrying cap of the flashlight as originally manufactured.

A screen 21 surrounds the light source or bulb 16 to affect the radiation therefrom. As here shown the

screen 21 is cylindrical in form and is axially disposed within the envelope 17, immediately surrounding the bulb. In order that the screen 21 may be fixedly positioned to surround the light source its outer end is cemented to the inner surface of the lens or bull's-eye 18. The screen 21 preferably extends rearwardly to the reflector 20. A second screen 22 is disposed in coaxial relation with respect to the first-named screen 21 for sliding in contact therewith to surround or clear the light source 16. Thus, the screen 22 has a shorter axial length than the screen 21 with respect to which it slides. As here shown the screen 22 is loosely mounted upon the screen 21 for sliding over that screen as the variable light torch 10 is pointed upwardly or downwardly; and it is preferred to cement the adjacent end of the screen 21 to the reflector 20 to prevent the movable screen 22 from sliding off of the fixed screen 21 when the combination of elements 12 is removed from the flashlight 11. However the screen 22 is not necessarily positioned externally of the screen 21.

The two screens 21 and 22 are different in light-transmitting characteristics in order that visible radiation from the light source may be varied according to the relative positions of the screens. Accordingly, the visible radiation from the bulb 16 will be of different quality with only the screen 21 surrounding it from that resulting when both screens surround it. For example, the screen 21 may be of one color and the screen 22 of a different color.

In one embodiment of the invention the screen 21 is colored a light green so that, with the movable screen 22 displaced from the bulb 16, the visible radiation from the light source will be green as it passes directly through the transparent annular band 19 or is diffused through the frosted protective envelope 17. If, however, the lens 18 is a red bull's-eye the visible radiation from the light source will pass axially from the variable light torch as a red beam.

If the second screen 22 is colored red it will cause the visible radiation from the light source to be projected as a red color through the transparent annular band 19 when it slides into position to surround the light source. At the same time it will cause the diffused light showing through the frosted envelope 17 to be red in color. The bull's-eye 18, if colored red, will always cause a red beam to be projected axially from the torch regardless of the position of the movable screen 22.

From the foregoing, operation of the variable light torch will be apparent. If the screen 21 which fixedly surrounds the light source is colored green and if the second slidable screen 22 and the lens 18 are colored red, then a warning red signal may be given by pointing the torch upwardly. In order to give a permissive or "all clear" signal it is merely necessary to incline the torch downwardly. See Fig. 3. In this position the movable screen 22 moves by gravity away from the light source 16 along the fixed screen 21. Light from the bulb 16 accordingly passes through the green fixed screen, with the result that the visible radiation passing directly through the transparent annular band 19 is green in color as is the light which is diffused through the frosted envelope 17. Little light passes through the movable screen 22, as will be evident upon inspection of Fig. 3. It is particularly noted that if the lens 18 is colored red the visible radiation projected axially from the torch is always red.

The present invention is of value in a number of uses. For example: A policeman directing traffic at a poorly lighted intersection may signal cars approaching in all directions to stop merely by pointing the variable light torch upwardly. The bull's-eye 18 and movable screen 22, both being red in color, will cause all visible radiation from the torch to show as red. On the other hand, by turning the torch downwardly the visible radiation in all directions will show as green and

traffic may be waved in any desired direction. In order to stop traffic moving toward the policeman in any direction it is merely necessary to point the torch toward the oncoming traffic, whereupon a red beam is projected toward this oncoming traffic. If, however, the torch is pointed slightly downwardly green will be seen from directions at right angles to that of the oncoming traffic which is stopped, or indeed such traffic may be waved on by lateral movement of the torch.

It is particularly to be noted that in all positions of the torch a certain diffused illumination is projected rearwardly so that the policeman may be at least dimly seen, thereby avoiding accident to him from moving traffic.

Other uses of a variable light torch constructed and arranged according to the invention include use by pedestrians along a road at night and use by motorists in case of breakdown or accident. In the first instance the pedestrian has with him means to indicate his presence and to diffuse light upon his person while walking along a highway with the torch pointed downwardly. To give a danger signal it is merely necessary to point the torch upwardly. In the second instance the torch may be held in the hand of the car owner or a passenger and pointed upwardly to give a danger signal, it may be held in the hand pointed downwardly to indicate the presence of the car owner or his car or it may be placed upon the pavement standing upon its butt to give a danger signal behind the car and prevent collision. Should the torch fall over from its upstanding position it will still show red and give a warning signal, as best indicated in Fig. 4 of the drawings.

For the purposes described herein it is preferred that screen 21 is colored green and screen 22 is colored red. Other uses of the variable light torch will, of course, be possible as in the case of campers, yachtsmen, and possibly military and semi-military personnel.

The form of the invention here described and illustrated is presented merely as an example of how the invention may be applied. Other forms, embodiments and applications of the invention coming within the purview of the inventive thought and the proper scope of the appended claims will, of course, suggest themselves to those dealing with such problems.

I claim:

1. A variable light torch comprising a light source, a cylindrical colored screen fixedly surrounding said light source, and a second cylindrical screen of a color different from said first-named screen having a shorter axial length than that of said first-named screen loosely mounted thereon for movement over said first-named screen as the variable light torch is pointed upwardly or downwardly, whereby the position of the torch and the resulting position of said second screen will determine the color radiation from said light source.

2. A variable light torch comprising a light source, a frosted envelope surrounding said light source, a cylindrical colored screen fixedly surrounding said light source within said envelope, and a second cylindrical screen of a color different from said first-named screen having a shorter axial length than that of said first-named screen loosely mounted thereon for movement over said first-named screen as the variable light torch is pointed upwardly or downwardly, whereby the position of the torch and the resulting position of said second screen will determine the color radiation from said light source, and whereby such color radiation is diffused through said frosted envelope.

3. A variable light torch comprising a light source, a cylindrical frosted envelope surrounding said light source having an unfrosted substantially transparent annular band immediately surrounding said light source, a cylindrical colored screen fixedly surrounding said light source within said envelope, and a second cylindrical screen of a color different from said first-named screen having a shorter axial length than that of said first-named screen

5

loosely mounted thereon for movement over said first-named screen as the variable light torch is pointed upwardly or downwardly, whereby the position of the torch and the resulting position of said second screen will determine the color radiation from said light source, and whereby such color radiation is diffused through said envelope except for the substantially transparent annular band thereof through which the color radiation passes directly.

4. A variable light torch comprising a light source, a cylindrical frosted envelope surrounding said light source for diffusing the light therefrom, said envelope having a lens at its end opposite said light source for throwing a beam therefrom, a cylindrical colored screen fixedly surrounding said light source within said envelope and a second cylindrical screen of a color different from said first-named screen having a shorter axial length than that of said first-named screen loosely mounted thereon for movement over said first-named screen as the variable light torch is pointed upwardly or downwardly, whereby the position of the torch and the resulting position of said second screen will determine the color radiation from said light source.

5. A variable light torch comprising a light source, a cylindrical frosted envelope surrounding said light source having an unfrosted substantially transparent annular band immediately surrounding said light source, a bull's-eye fixed to the end of said envelope opposite to said light source for throwing a colored beam therefrom, and a cylindrical screen fixedly surrounding said light source within said envelope, said screen having a color different from that of said bull's-eye, in combination with a second cylindrical screen of the same color as said bull's-eye, said second cylindrical screen having a shorter axial length than that of said first-named screen and being loosely mounted thereon for movement over said first-named screen as the variable light torch is pointed upwardly or downwardly, whereby the position of the torch and the resulting position of said second screen will determine the color radiation from said light source through said envelope, and whereby such color radiation is diffused through said envelope except for the substantially transparent annular band thereof through which the color radiation passes directly.

6. A variable light torch comprising a flashlight, a cylindrical colored screen fixedly surrounding the bulb of said flashlight and a second cylindrical screen of a color different from said first-named screen having a shorter axial length than that of said first-named screen loosely mounted thereon for movement over said first-named screen as said flashlight is pointed upwardly or downwardly, whereby the position of the flashlight and

6

the resulting position of said second screen will determine the color radiation from the bulb of said flashlight.

7. A variable light torch comprising a flashlight, a cylindrical frosted envelope surrounding the bulb of said flashlight and having an unfrosted substantially transparent annular band immediately surrounding the bulb of said flashlight, and a cylindrical colored screen fixedly surrounding the bulb of said flashlight within said envelope, in combination with a second cylindrical screen of a color different from said first-named screen having a shorter axial length than that of said first-named screen loosely mounted thereon for movement over said first-named screen as said flashlight is pointed upwardly or downwardly, whereby the position of said flashlight and the resulting position of said second screen will determine the color radiation from the bulb of said flashlight, and whereby such color radiation is diffused through said envelope except for the substantially transparent annular band thereof through which the color radiation passes directly.

8. A variable light torch comprising a flashlight, a cylindrical frosted envelope surrounding the bulb of said flashlight and detachably fixed to said flashlight, said envelope having an unfrosted substantially transparent annular band immediately surrounding the bulb of said flashlight, a bull's-eye fixed to the end of said envelope opposite to the bulb of said flashlight for throwing a colored beam therefrom, and a cylindrical screen fixedly surrounding the bulb of said flashlight within said envelope, said screen having a color different from that of said bull's-eye, in combination with a second cylindrical screen of the same color as said bull's-eye, said second cylindrical screen having a shorter axial length than that of said first-named screen and being loosely mounted thereon for movement over said first-named screen as the variable light torch is pointed upwardly or downwardly, whereby the position of the torch and the resulting position of said second screen will determine the color radiation from the bulb of said flashlight through said envelope, and whereby such color radiation is diffused through said envelope except for the substantially transparent annular band thereof through which the color radiation passes directly.

References Cited in the file of this patent

UNITED STATES PATENTS

2,104,911	Snyder	Jan. 11, 1938
2,225,825	Desimone	Dec. 24, 1940
2,347,531	Yardeny	Apr. 24, 1944
2,486,998	Szeklinski	June 19, 1948
2,611,019	Warner	Sept. 16, 1952