

(No Model.)

2 Sheets—Sheet 1.

J. & J. M. CRAWSHAW.

STARCH MANGLE.

No. 258,895.

Patented June 6, 1882.

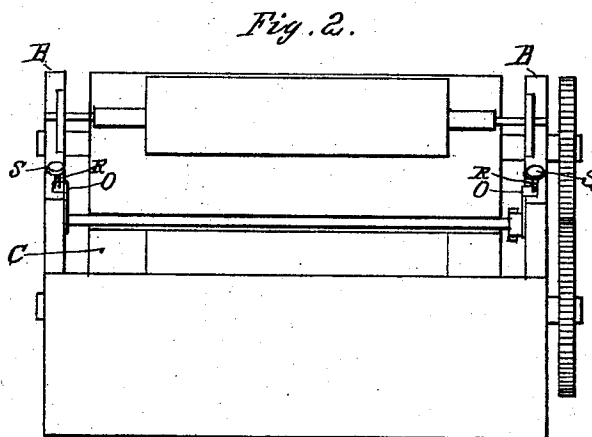
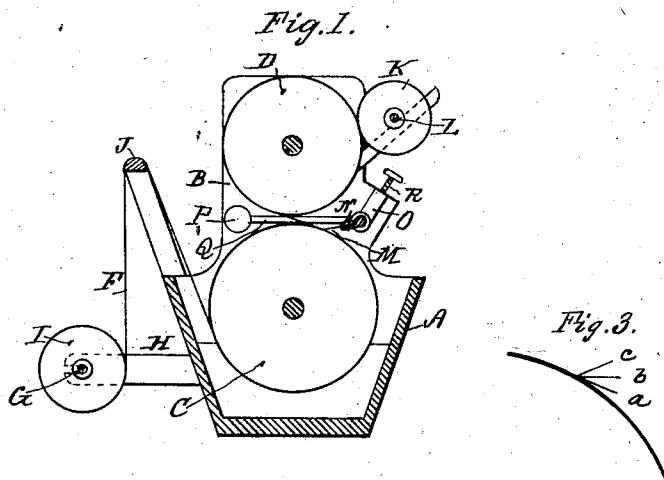

Witnesses.

Benjamin G. Luther.

Alva R. Abbott

Inventors.

John Crawshaw  
John M. Crawshaw  
per S. Scholfield  
Attorney

(No Model.)

2 Sheets—Sheet 2.

J. & J. M. CRAWSHAW.  
STARCH MANGLE.

No. 258,895.

Patented June 6, 1882.

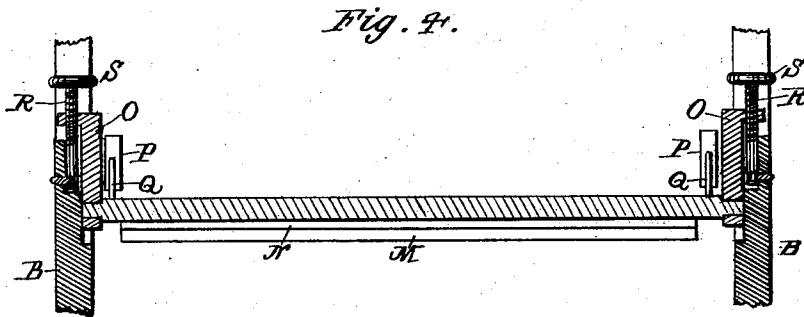

Witnesses.  
Jesse D. Bottrell  
Wellington P. Dolloff

Inventors.  
John Crawshaw  
John McCrawshaw  
per S. Scholfield  
Attorney

# UNITED STATES PATENT OFFICE.

JOHN CRAWSHAW AND JOHN M. CRAWSHAW, OF CENTRAL FALLS, R. I.

## STARCH-MANGLE.

SPECIFICATION forming part of Letters Patent No. 258,895, dated June 6, 1882.

Application filed January 7, 1882. (No model.)

To all whom it may concern:

Be it known that we, JOHN CRAWSHAW and JOHN M. CRAWSHAW, of Central Falls, in the county of Providence, in the State of Rhode Island, have invented an Improvement in Starch-Mangles, of which the following is a specification.

Our invention relates to an improvement in mangles for starching goods in bleacheries; and it consists in the employment of a pivoted doctor-plate arranged to rest with a forward inclination upon the surface of the starched web with a yielding pressure, and combined with means for varying the angle of the doctor-plate, as hereinafter set forth.

Figure 1 represents a central transverse section of the machine. Fig. 2 represents a front elevation of the same. Fig. 3 represents sectional details, enlarged. Fig. 4 represents a section taken through the pivots of the doctor-plate in the plane of the axis of the adjusting-screws.

In the ordinary starch-mangle the cloth, after passing through the starch-fountain, passes between two pressure-rolls, which serve to force the starch into the interstices of the threads and to remove the surplus starch from the surface of the cloth; but the action of such pressure-rolls upon the starched fabric is not of such a nature as to produce the proper desired effect, and for this reason it becomes necessary to pass the cloth two or three times through the machine, with intermediate drying of the starched goods, which entails expense and loss of time. We have so improved the mangle, by the employment of a doctor-plate held against the surface of the cloth with a yielding pressure by means of a weight or an equivalent spring, that a single passage of the cloth through the mangle is amply sufficient for the full saturation of the fabric, and in lieu of the adjustment of the pressure-rolls in the ordinary mangle we properly gage the quantity of starch to be left upon the fabric by changing the angular position of the inclined doctor-plate with reference to the surface of the fabric. We are thus enabled to force the starch into the interstices of the threads and to properly smooth off the surface, as required, at one operation; and the substitution of a doctor-plate operating under a yielding pressure, as

above mentioned, in lieu of the pressure-rolls heretofore employed in starch-mangles, is the gist of our invention, producing highly desirable results, both with regard to the quantity of cloth which may be starched in a given time and in the quality of the work performed.

In the drawings, A represents a trough for holding the starch. B B are standards at each end of the starch-fountain A, for supporting the rolls. The starching-roll C rests in its end bearings, with the lower surface of the roll embedded in the starch of the fountain. The roll D, having a vacant space between its cylindrical surface and the surface of the roll C, is operatively connected to the roll C by means of the gears E E.

The web F to be starched is first placed in a rolled condition upon a removable shaft, G, held in suitable supports, H H, arranged at the opposite ends of the machine. The web passes from the roll I over the fixed stretching-bar J, thence under the roll C through the starch-fountain, thence under the doctor-plate M, and through the space left vacant between the rolls C and D, to the winding-up roll K upon the shaft L, which is operated by the frictional contact of the rolled web with the surface of the roll D, as usual in such machines.

The doctor-plate M, held in the jaws N N, is pivoted in the sliding boxes O O at opposite ends of the machine, and is held down upon the surface of the web by means of the weight P, made adjustable upon the arm Q, attached to the doctor-plate clamp N N. The sliding boxes O O are operated to change the angular position of the doctor-plate with reference to the surface of the cloth by means of the adjusting-screws R R and hand-wheels S S, so that by raising or lowering the boxes O O by means of the adjusting-screws the angle of the doctor-plate with the surface of the roll C and surface of the web will be varied, so that a greater or less quantity of starch may be forced into the fabric. Thus, when the doctor-plate is in the angular position *a* in Fig. 3, the starch will be forced into the web in a greater quantity than when in the angular position *b*, and in still greater quantity than when in the position *c*. The yielding pressure upon the doctor-plate secured by the weight P provides for the passage of the spliced ends of the fabric

when several webs are joined in the same roll, as common in bleaching operations, rendering the employment of a rigidly-set doctor-plate impracticable.

5 We are aware that rigidly-set doctor-plates have been employed in printing-machines to remove the surplus ink from the fountain ink-roll; but the employment of a rigidly-set doctor-plate for such a purpose is not analogous  
10 to the employment of a yielding doctor-plate arranged to both remove the surplus starch from a web of freshly - starched cloth and to force the starch into the interstices of the threads of the fabric, for which purpose a rigidly-set doctor-plate would be impracticable.  
15

We therefore claim as our invention—  
In a starch - mangle, the starch - fountain,

starch - fountain roll, and the pivoted doctor-plate, with mechanism for giving it a yielding pressure, in combination with means for adjustably varying the angle of the doctor-plate with respect to the surface of the starch-fountain roll, and with mechanism for drawing the cloth through the starch and between the yielding doctor-plate and the starch-fountain roll, substantially as described. 20 25

JOHN CRAWSHAW.  
JOHN M. CRAWSHAW.

Witnesses:

C. MORRELL,  
P. SCHENCK,  
HARMON S. BABCOCK,  
SOCRATES SCHOLFIELD.