

B. D. HEALEY.

APPARATUS FOR MELTING AND MIXING BITUMINOUS COMPOUNDS.

No. 277,277.

Patented May 8, 1883.

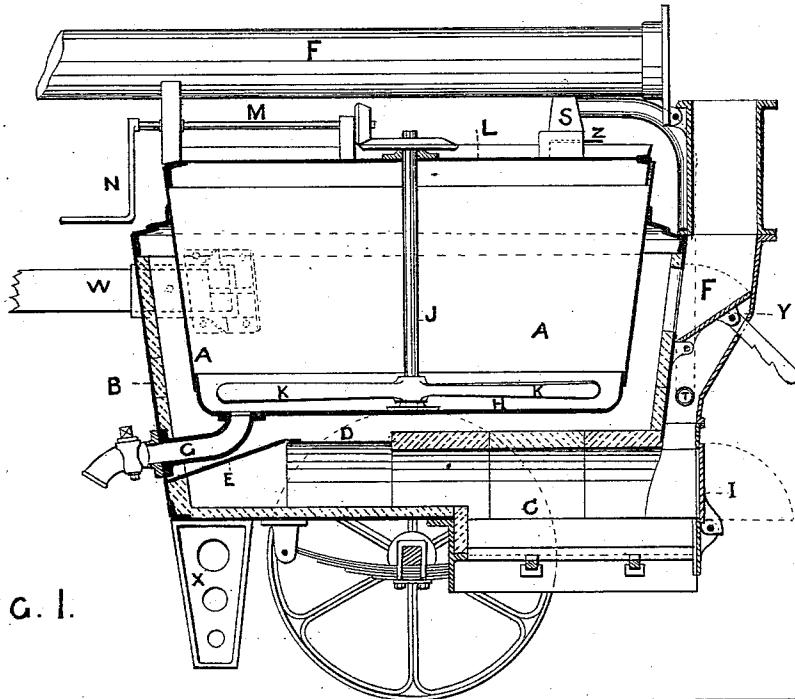

FIG. 1.

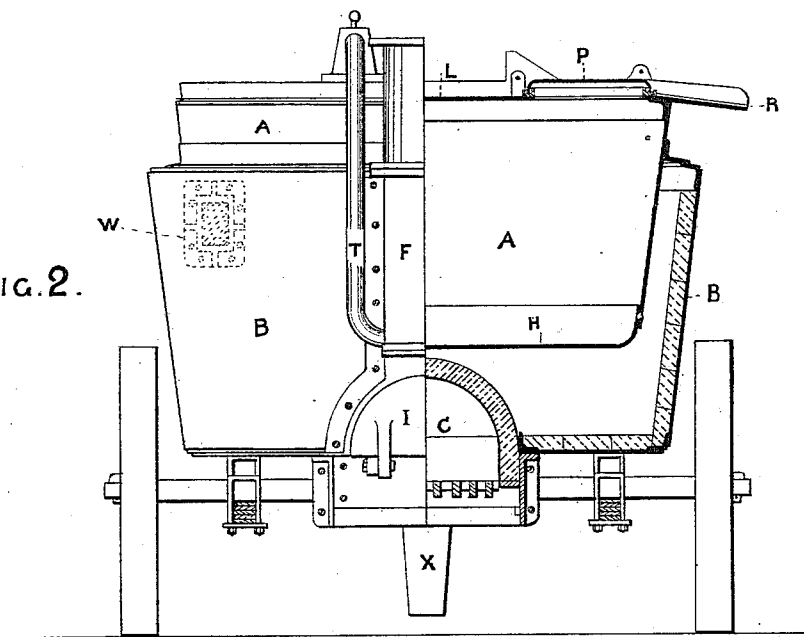

FIG. 2.

Witnesses:  
*W. C. Young.*  
*J. W. Howard*

Inventor:  
*Burley Denham Healey*  
 by *W. H. Doolittle,*  
 Attorney.

B. D. HEALEY.

APPARATUS FOR MELTING AND MIXING BITUMINOUS COMPOUNDS.  
No. 277,277. Patented May 8, 1883.

FIG. 3.

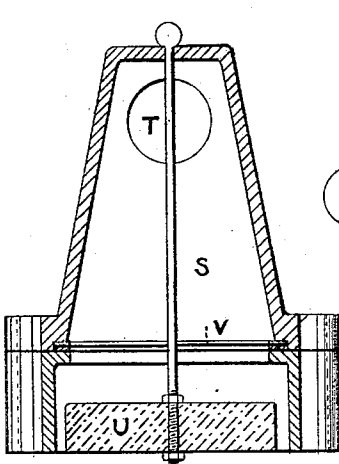
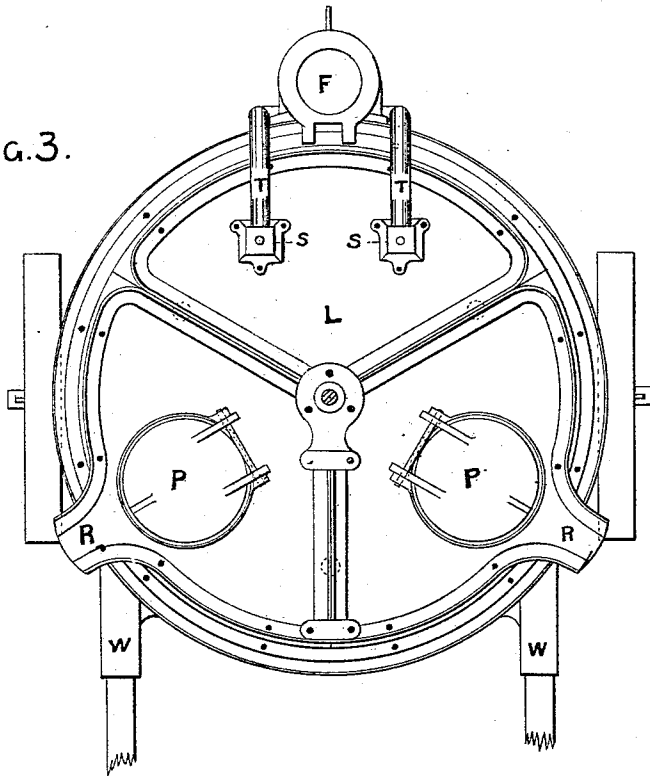

FIG. 4.

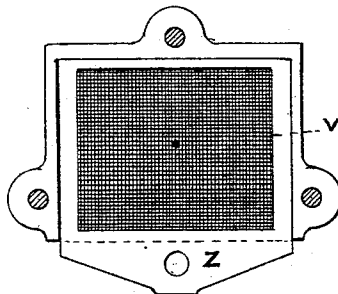

FIG. 5.

Witnesses:  
*M. C. Young.*  
*J. W. Coward*

Inventor:  
*Brierley Denton Healey*  
*J. W. Doolittle*  
 Attorney

# UNITED STATES PATENT OFFICE.

BRIERLEY D. HEALEY, OF LIVERPOOL, COUNTY OF LANCASTER, ENGLAND.

APPARATUS FOR MELTING AND MIXING BITUMINOUS COMPOUNDS.

SPECIFICATION forming part of Letters Patent No. 277,277, dated May 8, 1883.

Application filed November 1, 1882. (No model.) Patented in England October 4, 1881, No. 4,297, and August 9, 1882, No. 3,783.

*To all whom it may concern :*

Be it known that I, BRIERLEY DENHAM HEALEY, a subject of the Queen of Great Britain and Ireland, residing at Liverpool, in the county of Lancaster, Kingdom of Great Britain and Ireland, have invented new and useful improved apparatus for melting and mixing bituminous compounds and like substances and treating the pungent gases therefrom, (for which I have obtained patents in Great Britain, No. 4,297, bearing date October 4, 1881, and No. 3,783, bearing date August 9, 1882,) of which the following is a specification.

My invention relates to improved apparatus for melting and mixing bituminous fatty or similar compounds or substances, and for collecting and decomposing the pungent gases evolved in the process. The material or compound is melted in a pan or boiler having a large surface exposed to the heating medium, the gases being taken off by pipes communicating with the interior of pan and delivered to the flue. A piece of wire-gauze is inserted in the gas-passage to prevent the gases from firing in the pipe and igniting the boiling substance, and is protected from being choked, should the liquid boil up, by a float that rises and closes the opening to the pipe. I provide a winged stirrer for mixing the material or compound, and I place this low in the pan to assist in keeping the bottom clean. I construct the flues over the fire-place with curved fire-blocks, and I also line the outer casing with fire-brick.

Referring to the accompanying two sheets of drawings, Figure 1 is a longitudinal sectional elevation of the apparatus. Fig. 2 is a half-sectional elevation of the same. Fig. 3 is a plan with chimney and gearing removed. Fig. 4 is a sectional elevation of the float-box and sliding wire-gauze frame. Fig. 5 is a plan of the same with the upper part removed, showing the wrought-iron frames in which the layer of wire-gauze is inserted.

Similar letters refer to similar parts throughout the several views.

The inner or boiling pan, A, and the outer casing, B, Figs. 1 and 2, are in the form of truncated cones. The casing B is lined with fire-bricks both on its sides and bottom, except where the fire-bars are fixed.

The fire-place C is covered over with curved fire-brick covers, and the flue with an iron or steel plate, D, curved to the same radius as the fire-bricks. Beyond this a flat plate, E, is fixed with its further end resting on the fire-brick lining of the outer casing. This plate is open at the sides to allow the heated gases or flame to spread out in each direction and pass round the pan on their way to the flue or chimney F. It also serves to protect the outlet branch G and the side of casing from being burnt away so rapidly.

The pan A is provided with a dished bottom, H, riveted into the shell, and has an outlet-pipe, G, terminating in a plug-valve bolted to it. It is also provided with a footstep for carrying the vertical shaft J, which has one or more stirrers, K, fixed to it. The upper end of the said shaft runs in a bearing secured to the lid or cover L, and is driven by a pair of bevel-wheels from the shaft M, which is provided with a handle, N.

Charging-holes P are formed on the cover or lid L, and are furnished with rings, lids, and hinges. The rings are of trough-section, with the inner flange higher than the outer one to prevent rain-water getting into the pan, and each lid has a flange which dips into the troughs, as shown.

Opposite each charging-hole an overflow-spout, R, is formed, the sides of which are made of angle-iron, shaped to join and stiffen the lid-plates, as shown in Fig. 3.

Cast-iron sockets W, Fig. 3, are riveted onto the outer casing for the reception of movable shafts.

To the pan-top two cast-iron boxes or junctions, S, Figs. 3 and 4, are bolted, the lower portion of each of which contains a cork float, U, Fig. 4, fastened onto a small rod, by which it is guided.

Two thin wrought-iron sliding pieces Z, Fig. 5, constitute a frame to carry a layer of wire-gauze interposed between the pipe T and the boiler, so that should the gas fire in the pipe T it will not ignite the contents of the boiler.

The gas-pipes are led down by the side of the flue-casing F, and are inserted below the double-acting damper Y. This damper is furnished with a notched bar, and is so arranged that a portion of the heated gases or flame

may be directed direct up the flue, if desired, without passing under and around the inner pan.

5 The fire-place door I, Figs. 1 and 2, is carried on horizontal hinges, and is provided with stops, so that when the door is open it forms a sill.

10 Under the back end of outer casing a crutch or stop, X, is bolted on for the pan to rest on when in use.

15 The pan A and lid L are held in position by twelve (or other multiple of three) bolts pitched at equal distances, so that when one portion of the pan A is wearing thin the bolts may be taken out and the pan itself turned 20 round a third of a revolution, or one hundred and twenty degrees, thus bringing the bolt-holes true with each other again. The pan-bottom has also three holes divided the same way, two of them being closed with blank 25 flanges, so that the pipe G can be coupled up afresh to the pan A after the latter has been turned. By this means wear can be equally distributed all over the pan, and the whole material used up before it requires to be repaired or renewed.

30 The whole apparatus may be mounted on traveling wheels and springs, and have shaft-boxes W riveted to it for drawing it by horse-power. The wheels are built up of wrought-iron, somewhat similar to ordinary railway-wagon wheels.

35 I do not lay any general claim to the use, in apparatus for the purpose specified, of an inner boiler with an outer casing, as I am aware such arrangements have before been proposed.

What I claim is—

1. In an apparatus for melting and mixing bituminous compounds and like substances, 40 the combination of a pan, a surrounding brick-lined case, and one or more stirrers arranged within and near the lower part of said pan, so as to act both to mix the contents and to keep the bottom clear of cakes or deposits 45 of the material under treatment, substantially as described.

2. In an apparatus for melting and mixing bituminous compounds and like substances, the combination, with a pan containing one or 50 more stirrers and a brick-lined surrounding-case, of a fire-place or furnace having the upper part covered with fire-blocks, and a layer of thick fire-brick opposite the exit end of the flue to prevent injurious action of the flame 55 on the outer casing, substantially as described.

3. In an apparatus for melting and mixing bituminous compounds and like substances, the combination, with a pan with surrounding-case and flue, as above set forth, of a float, U, 60 wire-gauze V, and pipe T, opening into said flue, substantially as described.

4. The combined apparatus for melting and mixing bituminous compounds and like substances, comprising the pan or boiler A, with 65 charging-holes P, overflow-spouts R, and stirrers K, brick-lined surrounding-case B, fire-place C, flue or chimney F, with damper Y, and other parts, as described and illustrated.

BRIERLEY DENHAM HEALEY.

Witnesses:

FREDERICK McCLURE SCOTT,

ALFRED BEAUMONT,

*Both of 89 Victoria Street, Liverpool.*