



(11) **EP 1 107 201 B1**

(12) **EUROPEAN PATENT SPECIFICATION**

(45) Date of publication and mention of the grant of the patent:
14.02.2007 Bulletin 2007/07

(51) Int Cl.:
G07F 13/10^(2006.01) G07F 13/06^(2006.01)

(21) Application number: **00124973.9**

(22) Date of filing: **16.11.2000**

(54) **Automatic beverage vending apparatus with improved arrangement for displacing the dispensing spouts**

Getränkverkaufsautomat mit verbesserter Anordnung zum Versetzen der Abgabestutzen

Machine de vente de boissons avec un arrangement amélioré pour déplacer les bec-verseurs

(84) Designated Contracting States:
**AT BE CH CY DE DK ES FI FR GB GR IE IT LI LU
MC NL PT SE TR**

(30) Priority: **02.12.1999 IT PN990088**

(43) Date of publication of application:
13.06.2001 Bulletin 2001/24

(73) Proprietor: **N&W Global Vending S.p.A.
24030 Valbrembo (Bergamo) (IT)**

(72) Inventors:
• **Gavazzi, Stefano
24123 Bergamo (IT)**
• **Personeni, Silvano
24030 Mazzoleni, Bergamo (IT)**

(74) Representative: **Giugni, Valter et al
PROPRIA S.r.l.
P.O. Box 365
Via Colonna
33170 Pordenone (IT)**

(56) References cited:
**GB-A- 774 118 US-A- 3 622 047
US-A- 5 881 913**

- **PATENT ABSTRACTS OF JAPAN vol. 1997, no. 12, 25 December 1997 (1997-12-25) & JP 9 216695 A (SANYO ELECTRIC CO LTD), 19 August 1997 (1997-08-19)**

EP 1 107 201 B1

Note: Within nine months from the publication of the mention of the grant of the European patent, any person may give notice to the European Patent Office of opposition to the European patent granted. Notice of opposition shall be filed in a written reasoned statement. It shall not be deemed to have been filed until the opposition fee has been paid. (Art. 99(1) European Patent Convention).

Description

[0001] The present invention refers to an automatic beverage vending apparatus, in particular a hot-beverage vending apparatus, provided with an improved arrangement for displacing the beverage dispensing spouts.

[0002] Automatic hot-beverage vending apparatuses are usually provided, further to the devices and means needed to contain and process a multiplicity of ingredients for the preparation of the beverages, with a plurality of spouts through which the various beverages (ie. coffee, milk, tea and the like) are poured into the cups. The dispensing of the beverages themselves occurs in a compartment that is accessible by the customers, into which the cups are brought after being withdrawn, ie. picked automatically from their container. The spouts are usually gathered into a single functional cluster and are connected to the operating units of the apparatus via flexible hoses.

[0003] Top-quality vending apparatuses are provided with displacement systems that enable the spouts to be brought into their appropriate dispensing position when the customer requires it, and to be held in a protected position when the vending apparatus is not working or operating. The hygienic conditions of the vending apparatuses are in this way improved, since the possibility is eliminated for the dispensing spouts to be tampered with or contaminated from the outside of the vending apparatus. Furthermore, from a design engineering point of view, such a displacing arrangement of the spouts enables the vending apparatus to be made more compact by rationalizing space occupancies in a zone that accommodates quite a number of motor-driven systems (delivery and positioning of the cup, delivery of sugar, release of the mixing stick and the like).

[0004] For such a displacement of the dispensing spouts, both rotary or translatory movements on a plane that is substantially parallel to the floor and preferably rotary movements on a vertical plane are carried into effect.

[0005] US-A-3,622,047 discloses a liquid dispensing apparatus for general purpose comprising a dispensing nozzle which is driven to move between its charging and dispensing positions by a rocker arm. In order to reduce the danger of contamination of the liquid or the nozzle, the nozzle support includes closure means to automatically close the housing opening when the nozzle is in the charging position. Moreover, temperature-responsive means are provided for maintaining constant the temperature of the fluid within the storage chamber. However, no means is provided to ensure that the liquid do not stagnate into the delivery hoses leading to a situation of contamination of the apparatus. Such a situation is particularly dangerous in an automatic beverage vending apparatus.

[0006] Anyway, regardless of which type of construction is actually used in this connection, the critical point

of the system is represented by the delivery hoses, that is the hoses that convey the beverage from the operating units of the vending apparatus (ie. brewing units, mixing units and so on) to the dispensing spouts. These hoses follow of course the movements of the spouts as the latter are displaced, so that they can end up by arranging themselves in such a manner as to form pockets or even to get occluded owing to squeezing. In these cases, the beverage would be caused to stagnate there and, if the time elapsing from a beverage dispensing operation and the subsequent one turns out to be particularly long, it may undergo alterations leading to situations of dangerous contamination.

[0007] It therefore is a purpose of the present invention to provide an automatic beverage dispenser that is equipped with such improved means for the displacement of the dispensing spouts as to be able to do away with the above indicated drawback.

[0008] To such a purpose, the spouts are lifted abruptly at the end of the beverage dispensing operation and are subsequently brought into a resting position behind the dispensing compartment, while lowering their free ends so as to facilitate the delivery hoses to become completely empty.

[0009] The characteristics of the vending apparatus according to the present invention are as recited in the appended claims.

[0010] Anyway, advantages and features of the present invention will be more readily and clearly understood from the description that is given below by way of non-limiting example with reference to the accompanying drawings, in which:

- Figures 1A and 1B are schematical side and front views, respectively, of the beverage dispensing unit of an automatic vending apparatus according to the present invention, in the dispensing position thereof;
- Figures 2A and 2B are schematical views as those in Figures 1A and 1B of the beverage dispensing unit according to the present invention, in the resting position thereof;
- Figures 3A and 3B are schematical views as those in the preceding Figures of the beverage dispensing unit according to the present invention, in the resting position thereof; and
- Figure 4 is a rear schematical view of the beverage dispensing unit according to the present invention, in the dispensing position thereof.

[0011] With reference to the Figures, the dispensing unit of an automatic beverage vending apparatus, in particular a hot-beverage vending apparatus, comprises substantially:

- a plate 10 to which spouts 13 are attached for dis-

pensing the different beverages; the spouts are connected via respective hoses 14-16 to the operating units (ie. brewing units, mixing units and the like) of the vending apparatus, which may be of any known type and are not shown in the Figures;

- a cam 17 and a crank link 18 that constitute the actual displacing members, ie. the members that bring the spout-carrying plate 10 into movement; the link 18 is hinged at an end portion thereof on to the cam 17 and, at the other end portion thereof, carries the spout-carrying plate 10 that is hinged on thereto, while the cam 17 is in turn driven by a gearmotor 23 (Figure 4) of a known type;
- a shaped rocker-arm member 19, that is freely hinged at an end portion thereof on to the spout-carrying plate 10 and, at the other end portion thereof, to the inner structure 20 of the vending apparatus.

[0012] The dispensing unit is mounted inside the vending apparatus in a position that is closely adjacent to the dispensing compartment 21, in which a cup 22 is first brought and then supported, by means of known displacement means that are not shown in the Figures, in order to collect the dispensed beverage (Figures 1A-1B).

[0013] The connection implemented by means of the idle rocker arm 19 enables the problem to be solved consisting in bringing the spout-carrying plate 10 in its resting position behind the dispensing compartment 21. In such a position, in fact, the spouts 11-13 turn out to be practically inaccessible from the outside of the vending apparatus and, furthermore, they are set in the condition of enabling the respective delivery hoses 14-16 (Figures 3A-3B) to fully let off the liquid inside them, ie. to become completely empty.

[0014] The operation of the spout displacing means according to the present invention is as follows:

Assuming that the vending machine is going through a beverage dispensing phase (Figures 1A and 1B), the cup 22 has therefore been positioned in the dispensing compartment 21 and the spout-carrying plate 10 is arranged practically horizontally above the cup, so that the dispensing spouts 14-16 are located as close as possible to the same cup. It should be noticed in this connection that the end portions of the spouts can be situated even at a lower level than the level of the upper edge of the dispensing compartment 21. The beverage selected by the customer can therefore be dispensed under the best possible conditions, ie. with a minimum of heat losses in the case of hot beverages, as well as without any danger for the liquid to spatter or overflow from the cup. In addition, in such a position of the spouts, the delivery hoses are extended to the maximum extent, ie. to their full length, thereby ensuring perfectly regular flows of the beverages being served.

[0015] Upon conclusion of the beverage dispensing phase, the operating cycle of the vending apparatus usually provides for a few seconds of standstill in order to allow for a more intensive dripping, particularly in the case of beverages with a higher degree of density. The gearmotor is then energized, which, via the cam 17 and the link 18, causes the spout-carrying plate 10 to undergo a swift rotation (Figures 2A and 2B) so as to lift and incline upwards the end portions of the spouts 11-13, which are in this way kept in a position high above the dispensing compartment 21, but are actually lifted up to a higher level than the level of the upper edge of the same compartment. This operation brings about a drop-breaking effect that ensures the complete discontinuance of the beverage dispensing operation, owing also to the fact that the delivery hoses 14-16 are caused to temporarily flex.

[0016] The gearmotor then goes on rotating and, thanks to the connection established by means of the idle rocker arm 19, which oscillates about the point at which it is hinged on to the inner structure 20 of the vending apparatus, the spout-carrying plate 10 is caused to rotate in an anti-clockwise direction (Figures 3A and 3B). In this way, the end portions of the spouts 11-13 move over the upper edge of the dispensing compartment 21 and are brought in a position behind the same compartment, above a drip pan 31 provided for collecting possible leakage liquids. This position corresponds to the resting condition of the beverage dispensing unit and, therefore, of the vending apparatus.

[0017] It should be duly noticed that, by allowing the gearmotor to further rotate, this brings about a combined rotation of the spout-carrying plate 10, which is carried out in the opposite direction with respect to the afore described one. In fact, the plate 10 moves again through the intermediate position illustrated in Figures 2A and 2B and, finally, back into the dispensing position shown in Figures 1A and 1B. This is basically due to the double hinged, ie. pivotal connection of the plate 10 with the link 18, which is driven through the cam 17, and the idle rocker arm 19. The new dispensing operation will of course only be started after another cup has duly been placed in the dispensing compartment 21 and a dose of sugar and a mixing stick have possibly been poured into the same cup.

[0018] The described arrangement has following advantages:

- the spout displacement arrangement of the invention is very simple and compact, thereby enabling the utilization of the available space in the interior of the vending apparatus to be optimised;
- the unit that drives the spout displacement motion is a gearmotor which always rotates in the same direction;
- the dispensing spouts are kept in a protected position

when at rest, and are brought back into an ideal position when required to dispense a beverage;

- both delivery hoses and dispensing spouts are reliably allowed to become completely empty after a dispensing operation, so as to assure a maximum extent of hygiene in the use and the state of the vending apparatus.

[0019] It will be readily appreciated that the spout displacement arrangement according to the present invention can be subject to a number of modifications, that are within the capabilities of those skilled in the art, without departing from the scope of the present invention. For instance, the connection of the spout-carrying plate 10 to the inner structure 20 of the vending apparatus, which is implemented by means of the idle rocker arm 19, may be replaced by a sliding coupling of the stud-slot type, in which the plate is provided with a stud adapted to cooperate with a guide channel or groove provided in the structure.

Claims

1. Automatic beverage vending apparatus, in particular for selling hot beverages, comprising a plurality of dispensing spouts (11-13) connected via flexible hoses (14-16) to the various functional units provided to prepare the beverages, in which said dispensing spouts are mounted on a spout-carrying plate (10) that is driven to move with respect to the dispensing compartment (21) of the apparatus by motor-driven actuating means (17-18; 23) mounted on the inner structure (20) of the vending apparatus, **characterized in that** the actuating means (17-18; 23) for the displacement of the dispensing spouts (11-13) comprise coupling means (19, 30) that are adapted to bring about an abrupt upward rotation, of the spout-carrying plate (10) at the end of the dispensing operation, so as to create a drop-breaking effect.
2. Automatic beverage vending apparatus according to claim 1, **characterized in that** said coupling means between the spout-carrying plate (10) and the inner structure (20) of the vending apparatus are constituted by a rocker arm-type element (19), an end portion of which is pivotally connected so as to oscillate about a pivot (30) attached to the inner structure (20) of the vending apparatus, while the other end portion thereof is pivotally connected to the spout-carrying plate (10).
3. Automatic beverage vending apparatus according to claim 1 or 2, **characterized in that**, when at rest, the dispensing spouts (11-13) are moved into a position behind the dispensing compartment (21), outside the compartment itself, with their free end por-

tions positioned at a lower level than the upper edge of the walls of said dispensing compartment (21).

4. Automatic beverage vending apparatus according to any of the preceding claims 1 to 3, **characterized in that** the means for driving the spout-carrying plate (10) comprise a gearmotor (23) that is driven to rotate in a single and same direction.

Patentansprüche

1. Automatischer Getränkeverkaufsapparat, insbesondere zum Verkauf von heißen Getränken, mit einer Vielzahl von Ausgabeausgüssen (11-13), welche über flexible Schläuche (14-16) mit den unterschiedlichen funktionalen Einheiten verbunden sind, um Getränke zuzubereiten, wobei die Ausgabeausgüsse auf einer Ausgusträgerplatte (10) befestigt sind, welche durch motorgetriebene Antriebsmittel (17-18; 23) angetrieben sind, um sich relativ zu dem Ausgabefach (21) zu bewegen und die Antriebsmittel an der inneren Struktur (20) des Verkaufsapparats befestigt sind, **dadurch gekennzeichnet, dass** die Antriebsmittel (17-18; 23) zur Bewegung der Ausgabeausgüsse (11-13) Verbindungsmittel (19, 30) umfassen, welche durch eine abrupte aufwärtsgerichtete Drehung der Ausgusträgerplatte (10) am Ende des Ausgabevorgangs dafür sorgen, einen tropfenabbrechenden Effekt zu erzeugen.
2. Automatischer Getränkeverkaufsapparat gemäß Anspruch 1, **dadurch gekennzeichnet, dass** die genannten Verbindungsmittel zwischen der Ausgusträgerplatte (10) und der inneren Struktur (20) des Verkaufsapparats durch ein hebelarmähnliches Element (19) gebildet werden, dessen einer Endbereich drehbar mit der inneren Struktur (20) verbunden ist, um um einen Drehpunkt (30) zu drehen, der an der inneren Struktur (20) des Verkaufsapparats befestigt ist, während sein anderer Endbereich drehbar mit der Ausgusträgerplatte (10) verbunden ist.
3. Automatischer Getränkeverkaufsapparat gemäß Anspruch 1 oder 2, **dadurch gekennzeichnet, dass** in einer Ruhelage die Ausgabeausgüsse (11-13) in eine Position hinter dem Ausgabefach (21) bewegt sind, welche außerhalb des Ausgabefachs ist und ihre freien Endbereiche sich tiefer befinden, als die obere Kante der Wände des Ausgabefachs (21).
4. Automatischer Getränkeverkaufsapparat gemäß einem der vorangegangenen Ansprüche 1 bis 3, **dadurch gekennzeichnet, dass** die Mittel zum Antrieb der Ausgusträgerplatte (10) einen Getriebemotor (23) umfassen, welcher angetrieben ist, um sich in eine einzige und gleiche Richtung zu drehen.

Revendications

1. Distributeur automatique de boissons, en particulier pour la vente de boissons chaudes, comprenant une pluralité de becs de distribution (11-13) connectés via des tuyaux flexibles (14-16) aux diverses unités fonctionnelles fournies pour préparer les boissons, dans lequel lesdits becs de distribution sont montés sur une plaque porteuse de bec de distribution (10) qui est entraînée pour se déplacer par rapport au compartiment de distribution (21) de l'appareil par des moyens d'actionnement (17-18 ; 23) entraînés par moteur monté sur la structure intérieure (20) du distributeur, **caractérisé en ce que** les moyens d'actionnement (17-18 ; 23) pour le déplacement des becs de distribution (11-13) comprennent des moyens de couplage (19, 30) qui sont adaptés pour provoquer une rotation ascendante brusque de la plaque porteuse de bec de distribution (10) à la fin de l'opération de distribution, de sorte à créer un effet d'interruption du goutte à goutte.

5
10
15
20

2. Distributeur automatique de boissons selon la revendication 1, **caractérisé en ce que** lesdits moyens de couplage entre la plaque porteuse de bec de distribution (10) et la structure intérieure (20) du distributeur sont constitués d'un élément du type bras oscillant (19), une portion d'extrémité de celui-ci étant connectée de manière pivotante de sorte à osciller autour d'un pivot (30) attaché à la structure intérieure (20) du distributeur, tandis que l'autre portion d'extrémité de celui-ci est connectée de manière pivotante à la plaque porteuse de bec de distribution (10).

25
30

3. Distributeur de boissons automatique selon la revendication 1 ou 2, **caractérisé en ce que**, au repos, les becs de distribution (11-13) sont déplacés dans une position derrière le compartiment de distribution (21), en dehors du compartiment lui-même, avec leurs portions d'extrémité libres positionnées à un niveau inférieur au bord supérieur des parois dudit compartiment de distribution (21).

35
40

4. Distributeur automatique de boissons selon l'une des revendications précédentes 1 à 3, **caractérisé en ce que** les moyens pour entraîner la plaque porteuse de bec de distribution (10) comprennent un moteur à engrenages (23) qui est entraîné pour tourner dans une seule et même direction.

45
50

55

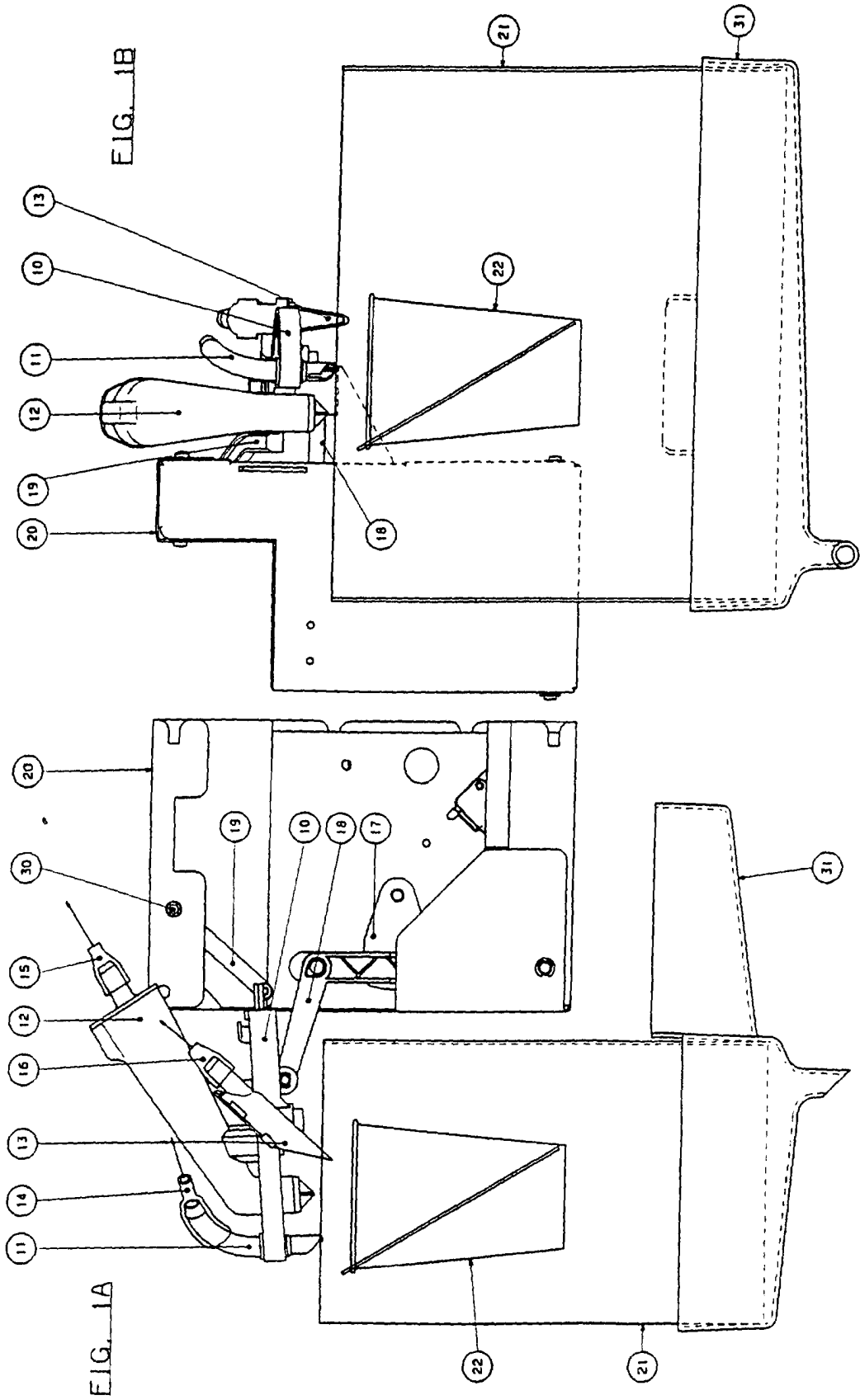

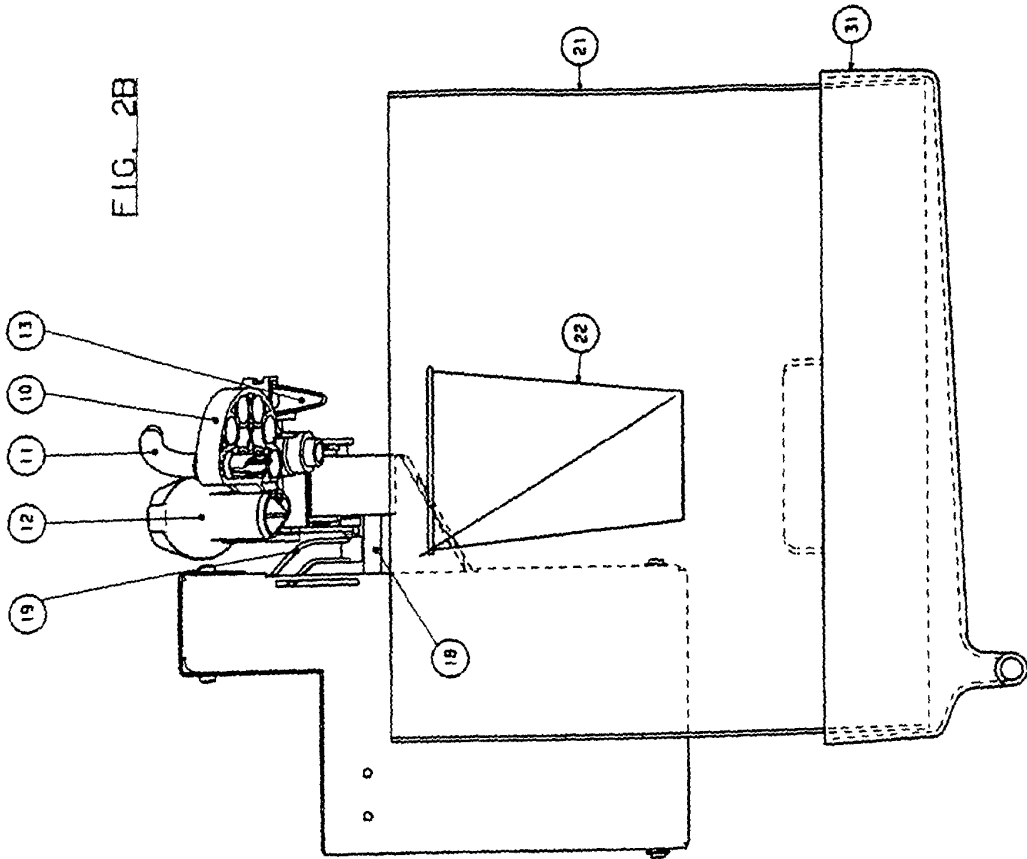

FIG. 2B

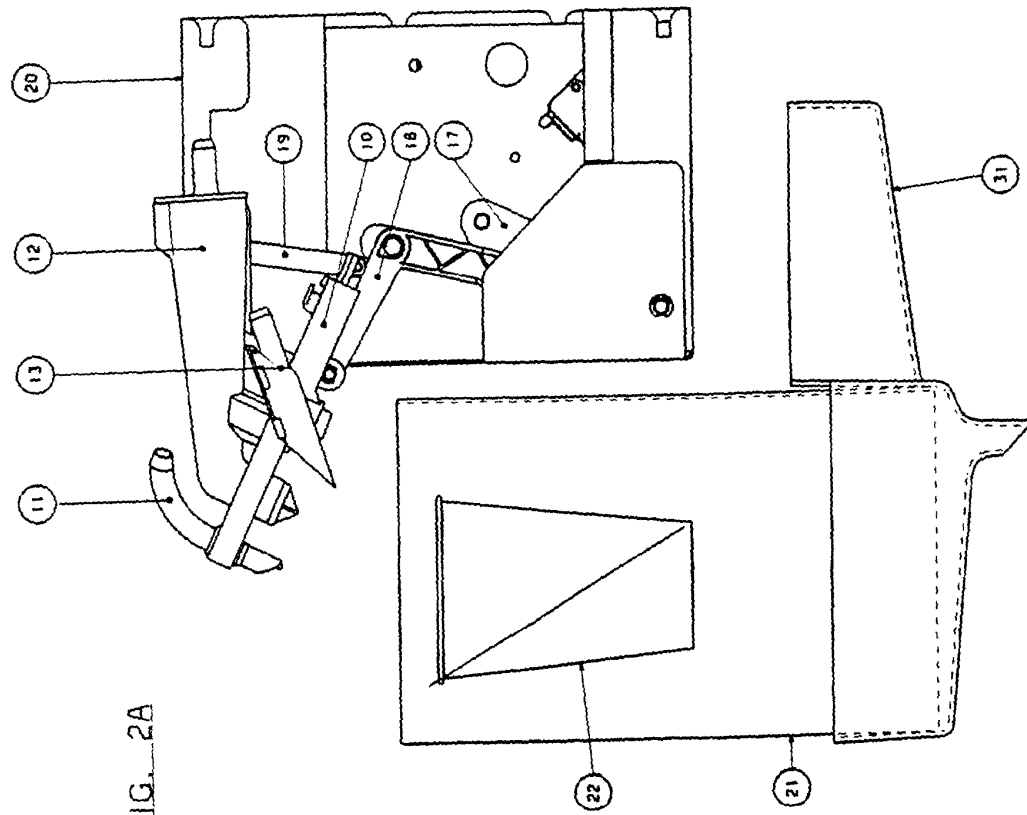

FIG. 2A

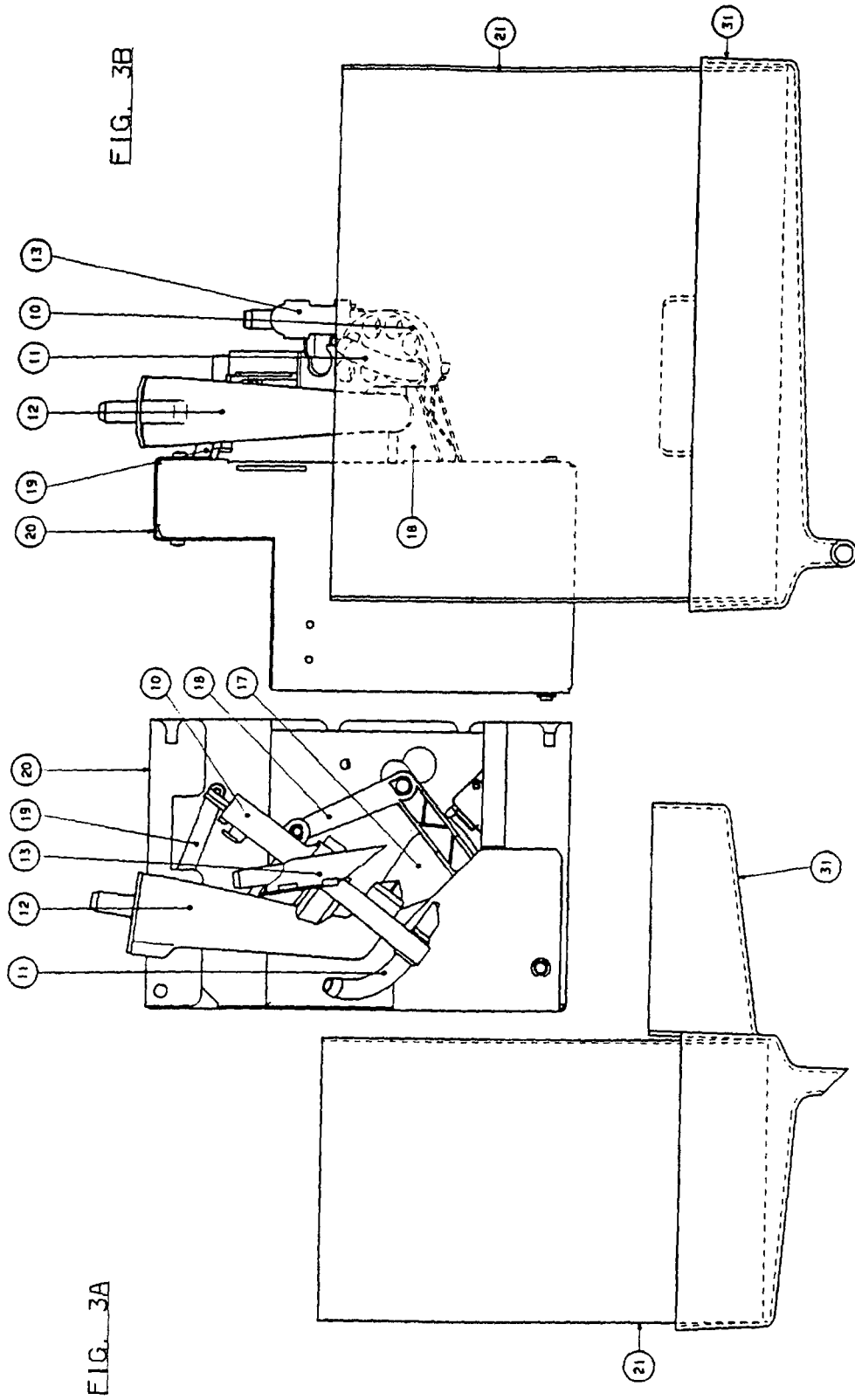

FIG. 4

