

June 12, 1956

R. L. SLOBOD ET AL

2,749,748

APPARATUS FOR CONTINUOUSLY LOGGING DRILL CUTTINGS

Filed July 16, 1951

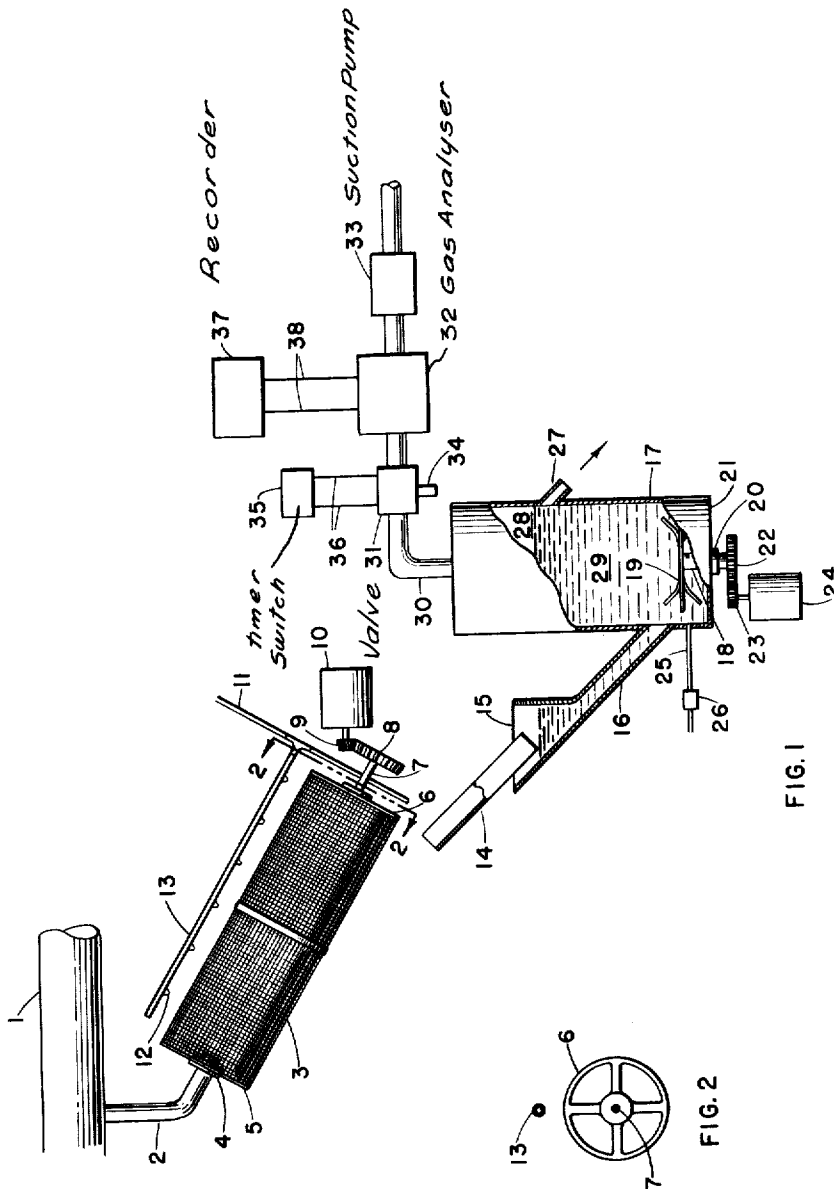

ATTEST

Clarence R. Potts, Jr.

INVENTORS
ROBERT L. SLOBOD
SIDNEY H. DAVIS
BY *Harbert C. Quirk*
ATTORNEY

1

2,749,748

APPARATUS FOR CONTINUOUSLY LOGGING DRILL CUTTINGS

Robert L. Slobod and Sidney H. Davis, Dallas, Tex., assignors to The Atlantic Refining Company, Philadelphia, Pa., a corporation of Pennsylvania

Application July 16, 1951, Serial No. 237,034

4 Claims. (Cl. 73—153)

This invention relates to apparatus for continuously logging an oil well during the drilling thereof, and more particularly to apparatus for continuously examining, for the presence of hydrocarbons, cuttings which are brought to the top of the well in drilling fluid which is circulated through the well during the drilling thereof by the rotary drilling method.

The most prevalent method of drilling oil wells in this country is that known as rotary drilling wherein a column of weighted drilling fluid is circulated down through the drill stem, through ports in the drill bit at the bottom of the well, and back to the surface of the ground through the annular space between the drill stem and the wall of the bore hole, carrying with it to the surface of the ground cuttings which are broken loose from the formations traversed by the drill bit. One of the major problems associated with drilling by this method is that there is frequently no appreciable indication given at the top of the well when an oil bearing formation is penetrated, due to the fact that the pressure exerted by the column of drilling fluid prevents the flow into the bore hole of any substantial amount of fluids which might be contained in such formations. Such being the case, when this method of drilling is used there is considerable danger that a petroliferous zone will be unknowingly drilled through and completely passed up.

Numerous methods have been devised to meet this problem, and among those methods suggested is one which contemplates collecting successive increments of the cuttings, identifying each increment with the approximate depth from which it was obtained, and subjecting each increment to one or more tests for the purpose of determining whether or not hydrocarbons are present therein. All known methods of logging a well by examination of the cuttings, however, operate on the "batch" theory and require the collection of successive samples which, after identification, are sent to a laboratory for analysis and correlation with other samples.

It is an object of this invention to provide apparatus for continuously and automatically examining for the presence of hydrocarbons successive increments of cuttings brought to the top of a well in drilling fluid circulated therethrough.

It is a further object of this invention to provide apparatus which automatically separates from the drilling fluid successive increments of cuttings brought to the top of the well therein, which automatically washes said cuttings and releases the gas therefrom, and which automatically and continuously examines said gas for the presence of hydrocarbons.

It is a further object of this invention to provide apparatus which may be installed at the site of a well being drilled, which is adapted to receive successive increments of the cuttings from said well in the order in which they are brought to the top thereof in the drilling fluid, and which automatically performs all the operations necessary to effecting the release of gases contained in said cut-

2

tings and analyzing said gases for the presence of hydrocarbons.

It is a further object of this invention to provide apparatus adaptable for the continuous analysis of cuttings brought to the top of a well in drilling fluid circulated therethrough which is adapted to continuously receive and analyze successive increments of said cuttings in the order in which they are brought to the top of the well, and which is further adapted to automatically give an indication of the presence of hydrocarbons in any increment of the cuttings analyzed.

Other objects and advantages of this invention will become apparent from the following description and attached drawings.

Figure 1 is a schematic representation of one embodiment of the apparatus which may be used in the practice of this invention.

Figure 2 is a sectional view of the shale-shaker component of the apparatus of Figure 1 taken on line 2—2 of said figure.

Briefly, this invention concerns apparatus whereby cuttings brought to the top of the well in drilling fluid may be continuously analyzed in the order in which they are brought to the top of the well and in which a positive indication will be provided when any increment which is analyzed contains hydrocarbons. In one form, the apparatus comprises a shale-shaker to which a portion of the cuttings in the drilling fluid may be passed in the order in which they arrive at the top of the well. The cuttings are urged along the shale-shaker while being subjected to streams of water, or other liquid, to remove the drilling fluid therefrom. The cuttings then pass from the shale-shaker, in substantially the same order in which they arrived thereon, into a trough or other channel through which they are conveyed to a comminuting chamber, where they are comminuted almost instantaneously so as to release any gases which they contain. The gases rise to the top of the comminuting chamber from which they may be withdrawn either periodically or continuously for analysis for the presence of hydrocarbons. In essence, the system is a dynamic one in that the cuttings move continuously through the apparatus from their entrance onto the shale-shaker until they leave the comminuting chamber in substantially the same relative order, and the released gases are analyzed in substantially that same order.

In the attached drawing, numeral 1 designates a section of the flow line through which drilling fluid which has reached the top of a well after circulation therethrough flows in its return to the mud pit for recirculation. A portion of the drilling fluid passing through line 1 is diverted through branch pipe 2 into shale-shaker 3 which, in the embodiment shown, is rotatably mounted at one end on pipe 2 as by bearing 4. In the particular embodiment shown in the drawing, shale-shaker 3 is made in the form of an elongated cylinder of screen wire attached at one end to plate 5 in which bearing 4 is mounted and attached at its other end to circular frame 6 which may resemble a spoked wheel, as more clearly shown in Figure 2. The hub of frame 6 has mounted thereon a shaft 7 to which is attached gear 8 which meshes with spur gear 9 adapted to be driven, as for instance, by electric motor 10 which may be supplied from any suitable source of alternating or direct current (not shown), whereby to rotate shale-shaker 3.

Pipe 11 is provided for supplying from a source, not shown, wash water, or other liquid, which may be directed through nipples 12 in branch line 13 onto shale-shaker 3 for a purpose to be explained below. Pipe 11 also supplies a stream of water to the top of trough 14 which is so located as to receive any material discharged from shale-shaker 3 and convey it into the enlarged en-

3

trance 15 of tube 16 which communicates with the interior of comminuting chamber 17.

Comminuting chamber 17 comprises a generally cylindrical container adapted to be mounted with its longitudinal axis vertical. A shaft 18 carrying comminuting blade assembly 19 is rotatably mounted as by bearing 20 in lower end wall 21 of chamber 17. Shaft 18 is adapted to be rotated through gears 22 and 23, as for instance by electric motor 24 which may be supplied with either alternating or direct current from any suitable source, not shown. A liquid inlet 25 is mounted in the wall of chamber 17 for supplying liquid to the interior thereof. A valve 26 is provided for controlling the flow of liquid through inlet 25. A liquid, such as water, is supplied to inlet 25 through valve 26 from a suitable source, not shown. Chamber 17 is also provided with a liquid outlet 27 through which liquid above the level thereof may flow outwardly from chamber 17. By regulating the rate of flow of liquid into chamber 17 by means of valve 26 the level of the liquid in chamber 17 may be maintained at any selected level above outlet 27 whereby to divide the interior of chamber 17 into two spaces, which, for the sake of convenience, will be referred to as gas collecting space 28, which comprises that portion of the interior of chamber 17 which is above the liquid level, and comminuting space 29 which comprises that portion of chamber 17 below the liquid level.

A conduit 30 is in communication with gas collecting space 28 and serves as a channel for withdrawing gas from said collecting space through valve 31, gas analyzer 32, and suction pump 33.

Valve 31 is preferably a 2-way valve which is designed to permit the passage of either gas from collecting space 28, through conduit 30, or atmospheric air, through conduit 34, depending upon the position of the movable member of said valve. The use of a valve of this type will permit continuous operation of the suction pump 33 even though it may be desired to withdraw gas from gas collecting space 28 only periodically, thus making the action of said pump more stable than if it were necessary to start and stop it intermittently. Valve 31 is preferably of the type which is adapted to be operated by a solenoid, not shown; and a timer controlled switch 35 is provided for periodically connecting leads 36 to a source of current, not shown, whereby to operate the solenoid of valve 31 according to any desired time cycle. The construction and operation of such valves and timer controlled switches are well known to those skilled in the art, and since they, per se, form no part of the present invention, a further description or discussion thereof is deemed unnecessary.

Analyzer 32 is preferably a gas analyzer of the hot filament type in which a heated filament, electrically included in a bridge circuit, is contacted by the gas to be analyzed. The presence of combustible gases causes a change in resistance of the filament and consequent unbalance of the bridge circuit. Since gas analyzers of this type are well known to those skilled in the art, no detailed description is thought to be necessary. An indicating or recording instrument 37 is connected to analyzer 32 through leads 38 to provide an indication of the detection of hydrocarbons by analyzer 32.

In operation, shale-shaker 3 is continuously rotated by electric motor 10. Also, water or other washing liquid is flowed constantly through pipe 11 whereby to cause a continuous discharge of water through nipples 12 which are directed on shale-shaker 3, and also to provide a constant stream of water at the top of trough 14.

A portion of the returning mud stream and the cuttings carried thereby are continuously diverted to shale-shaker 3 through branch pipe 2. The jets of water from nipples 12 wash substantially all of the drilling fluid from the cuttings which are retained within shale-shaker 3 by the screened walls thereof while the fluid components and the solids of small particle size pass therethrough. Be-

4

cause shale-shaker 3 is inclined downwardly, and because of the agitation incident to the rotation thereof, the cuttings tend to gravitate continuously to the lower end of shale-shaker 3 in a substantially constant stream and in substantially the same order as that in which they are deposited at the top thereof from pipe 2. Upon reaching the lower end of shale-shaker 3, the cuttings drop into trough 14, and move downwardly therealong, assisted by the stream of water directed on the top of trough 14 by pipe 11. The cuttings then pass from trough 14 into tube 16 through which they are conveyed to the interior of chamber 17.

Blade assembly 19 is continuously driven by motor 24 at a high rate of speed, for example 3500 R. P. M. As the cuttings enter chamber 17 in the vicinity of blade assembly 19, they are substantially instantaneously comminuted or disintegrated thereby. This disintegration of the cuttings results in releasing therefrom substantially all gases which were contained in the pores thereof, and these gases, being lighter than the liquid contained in chamber 17, rise to the gas collecting space 28 which lies above the liquid level.

The liquid, such as water, which enters chamber 17 through inlet 25 and which passes therefrom through outlet 27 serves the purpose of constantly removing the comminuted cuttings from chamber 17. Valve 26 is adjusted to regulate the flow of liquid into chamber 17 so as to maintain the level of liquid therein above the level of outlet 27. This insures that any gas which is released from the cuttings by comminution will not escape through outlet 27 but will remain entrapped in gas collecting space 28 until withdrawn therefrom through conduit 30.

The gas which is collected in gas collecting space 28 may be withdrawn for analysis either continuously or periodically, depending upon the desired method of operation. In most cases the rate of collection of gases from the cuttings will be so slow that it will be most advantageous to allow said gases to accumulate for a period of time before withdrawing them for analysis. For this reason, valve 31 is inserted in conduit 30 for controlling the flow of gas from gas collecting space 28. Valve 31 may be operated to permit either gas through conduit 30 or atmospheric air through conduit 34, to flow into the gas inlet pipe of analyzer 32. Timer 35 may be set to operate valve 31 according to any desired time cycle, or if it is desired to pass gases continuously from gas collecting space 28 to analyzer 32, valve 31 and timer 35 may be eliminated from the system.

Gas analyzer 32, which, as pointed out above, is preferably of the hot filament type, analyzes the gases passing therethrough for the presence of hydrocarbons. An electrical signal produced by analyzer 32 which varies in accordance with the concentration of hydrocarbons in the analyzed gases is transmitted through electrical leads 38 to instrument 37, preferably a recording instrument of the type well known to those skilled in the art which produces a continuous record of hydrocarbon content of the analyzed gases in the order in which they are analyzed.

It will be appreciated, of course, that it is necessary to coordinate the cuttings examined, with the depth in the well from which they were obtained, in order that the depth of the formation from which any hydrocarbon-bearing cuttings were taken may be identified. However, numerous methods of accomplishing this purpose by coordinating measurements of drilling rate and well-fluid circulation rate are known to those skilled in the art, and therefore a detailed discussion of such a method is not thought to be necessary to a complete understanding of this invention.

It will be obvious that the apparatus described above may be easily installed at the site of a well being drilled, and will function, after installation, to automatically provide a continuous record of the relative hydrocarbon content of cuttings passed to it in the order in which they are brought to the surface of the well in the drilling fluid.

5

Thus, as described above, there is provided a completely integrated and automatic system for the continuous analysis of cuttings in the order in which they are brought to the top of a well in the drilling fluid. The above described apparatus and method completely eliminate the need for collecting and individually handling successive increments of cuttings as has been necessary with prior methods and apparatus used in logging wells by cuttings analysis.

While there has been shown and described a single embodiment of apparatus for carrying out this invention it will be obvious to those skilled in the art that numerous minor changes may be made in such apparatus and method of operation without departing from the spirit of the invention. For example, it may, in some cases, be desirable to collect the cuttings from the entire stream of returning drilling fluid instead of from only a diverted portion thereof. Accordingly, this invention is not to be considered as limited to the specific embodiment herein described but rather as limited only in accordance with the appended claims.

We claim:

1. A comminuting chamber for continuously separating and collecting gas from a continuous stream of cuttings passed thereto after separation from drilling fluid as it reaches the surface of the earth after circulation through a well incident to drilling of the well by the rotary drilling method, including a closed chamber, said chamber having a first inlet through which cuttings may be passed thereinto in a substantially continuous stream, means in said chamber for comminuting said cuttings to release the gases therefrom substantially instantaneously upon their introduction into said chamber, a liquid inlet below said first inlet for supplying a liquid to said chamber, a liquid outlet above the level of said first inlet to permit the escape of liquid from said container, and means to maintain the liquid level in said chamber at a point above the level of the liquid outlet but below the level of the top of said chamber, whereby a gas collecting space is formed between the liquid level and the top of said chamber, the flow of liquid from said liquid inlet, through said container, and outwardly through said liquid outlet being sufficient to remove the cuttings from said chamber in a substantially continuous stream after comminution, and gas analyzing means communicating with said gas collecting space.

2. In a system for continuously logging a well during the drilling thereof by the rotary drilling method in which drilling fluid circulated from a fluid pit at the surface of the earth through the well and back to the fluid pit carries cuttings from the bottom of the well upwardly to the fluid pit, said system including means for separating a portion of the cuttings from the drilling fluid returning to the pit and for washing the cuttings so separated, and means for conveying the cuttings in a substantially continuous stream from the separating and washing means in the same order in which the cuttings are separated from the drilling fluid, the improvement comprising means for effecting the separation and collection of gas from the cuttings in substantially the order in which the cuttings occur in the continuous stream, said means including a closed chamber, a cuttings inlet for introducing the cuttings into the chamber in a substantially continuous stream, means in the chamber adjacent the cuttings inlet for continuously comminuting the cuttings introduced into the chamber to release gas from the cuttings substantially instantaneously upon their introduction into the chamber, means for continuously causing liquid to flow past the comminuting means at a rate such that the comminuted cuttings will be carried away by said liquid in substantially the same order in which the cuttings are introduced into the chamber, outlet means intermediate the top of the chamber and the cuttings inlet adapted for continuous removal of the liquid containing the comminuted cuttings from the cham-

6

ber at a rate so as to maintain a liquid level in the chamber below the top thereof whereby to form a gas collecting space between the liquid and the top of the chamber, and gas analyzing means communicating with said gas collecting space.

3. In a system for continuously logging a well during the drilling thereof by the rotary drilling method in which drilling fluid circulated from a fluid pit at the surface of the earth through the well and back to the fluid pit carries cuttings from the bottom of the well upwardly to the fluid pit, said system including means for separating a portion of the cuttings from the drilling fluid returning to the pit and for washing the cuttings so separated, and means for conveying the cuttings in a substantially continuous stream from the separating and washing means in the same order in which the cuttings are separated from the drilling fluid, the improvement comprising means for effecting the separation and collection of gas from the cuttings in substantially the order in which the cuttings occur in the continuous stream, said means including a closed chamber, a cuttings inlet for introducing the cuttings into the chamber in a substantially continuous stream, means in the chamber adjacent the cuttings inlet for continuously comminuting the cuttings introduced into the chamber to release gas from the cuttings substantially instantaneously upon their introduction into the chamber, means for continuously causing liquid to flow upwardly through the chamber at a rate such that the comminuted cuttings will pass upwardly with the liquid in substantially the order in which the cuttings are introduced into the chamber, outlet means intermediate the top of the chamber and the cuttings inlet adapted for continuous removal of the liquid containing the comminuted cuttings from the chamber at a rate so as to maintain a liquid level in the chamber below the top thereof whereby to form a gas collecting space between the liquid and the top of the chamber, and gas analyzing means communicating with said gas collecting space.

4. In a system for continuously logging a well during the drilling thereof by the rotary drilling method in which drilling fluid circulated from a fluid pit at the surface of the earth through the well and back to the fluid pit carries cuttings from the bottom of the well upwardly to the fluid pit, said system including means for separating a portion of the cuttings from the drilling fluid returning to the pit and for washing the cuttings so separated, and means for conveying the cuttings in a substantially continuous stream from the separating and washing means in the same order in which the cuttings are separated from the drilling fluid, the improvement comprising means for effecting the separation and collection of gas from the cuttings in substantially the order in which the cuttings occur in the continuous stream, said means including a closed chamber, a cuttings inlet for introducing the cuttings into the chamber in a substantially continuous stream, means in the chamber adjacent the cuttings inlet for continuously comminuting the cuttings introduced into the chamber to release gas from the cuttings substantially instantaneously upon their introduction into the chamber, a liquid inlet opening in said chamber below said cuttings inlet, means for continuously causing liquid to flow through the liquid inlet opening and upwardly past the comminuting means at a rate such that the comminuted cuttings will pass upwardly with the liquid in substantially the order in which the cuttings are introduced into the chamber, outlet means intermediate the top of the chamber and the cuttings inlet adapted for continuous removal of the liquid containing the comminuted cuttings from the chamber at a rate so as to maintain a liquid level in the chamber below the top thereof whereby to form a gas collecting space between the liquid and the top of the chamber, and gas analyzing means communicating with said gas collecting space.

(References on following page)

2,749,748

7

References Cited in the file of this patent

UNITED STATES PATENTS

563,733	Behrend et al. -----	July 14, 1896	
1,667,139	Borden -----	Apr. 24, 1928	
1,722,115	Sonsthagen et al. -----	July 23, 1929	5
1,847,864	Cross -----	Mar. 1, 1932	
2,229,884	Chakley -----	Jan. 28, 1941	

2,266,586
2,295,437
2,302,996
2,336,539
2,400,046
2,531,083

8

Branum -----	Dec. 16, 1941
Thompson -----	Sept. 8, 1942
Lilligren -----	Nov. 24, 1942
Gilbert -----	Dec. 14, 1943
Hummel -----	May 7, 1946
Smith -----	Nov. 21, 1950