

Feb. 9, 1932.

W. J. HEINTZ

1,844,576

HEADREST

Filed Oct. 28, 1929

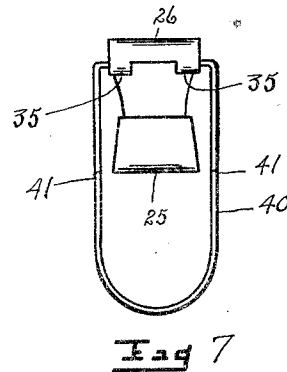
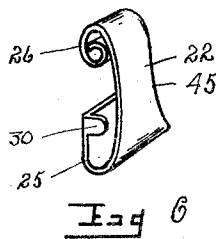
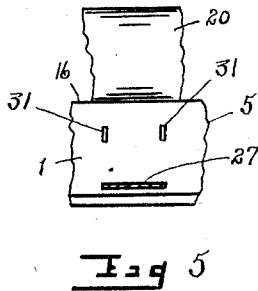
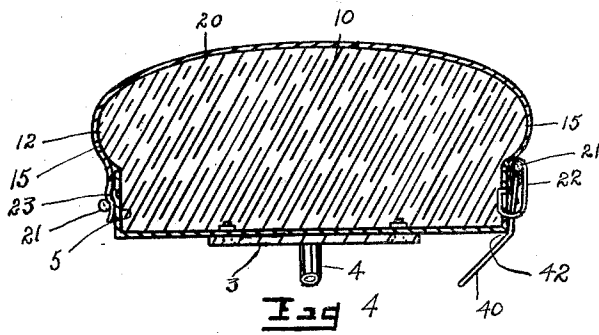
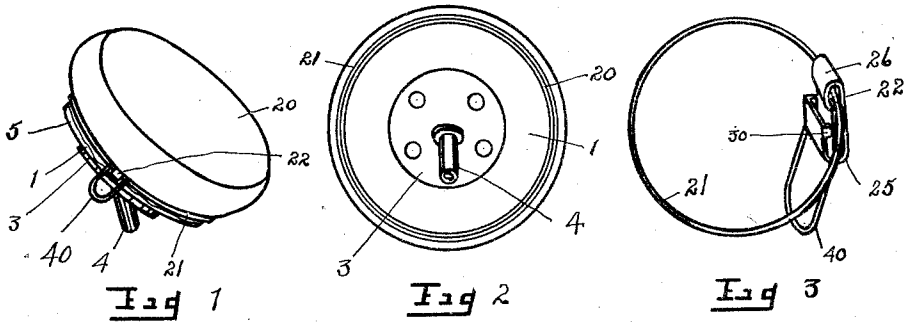

Inventor

William J. Heintz

Thomas L. Wilder

Attorney

UNITED STATES PATENT OFFICE

WILLIAM J. HEINTZ, OF UTICA, NEW YORK

HEADREST

Application filed October 28, 1929. Serial No. 402,902.

My invention relates to a head rest, and I declare the following to be a full, clear, concise and exact description thereof sufficient to enable anyone skilled in the art to which it appertains to make and use the same, reference being had to the accompanying drawings in which like reference characters refer to like parts throughout the specification.

The object of the invention is to provide a head rest used more particularly in connection with dental chairs. The head rest is adapted to support the head of the occupant of the chair in a comfortable manner. Furthermore, a detachable sheet of paper or napkin is placed over the surface of the cushion against which the head rests, whereby to present a sanitary surface for the back of the head of each occupant of the chair.

The object will be understood by referring to the drawings, in which:

Fig. 1 is a perspective view of the head rest.

Fig. 2 is a plan view looking at the underside of the head rest.

Fig. 3 is a detail view showing a band and parts for holding said band to the head rest.

Fig. 4 is an enlarged view showing a central vertical section of the head rest.

Fig. 5 is a detail fragmentary view showing an elevation of the head rest parts in section.

Fig. 6 is a detail enlarged view of a clip employed.

Fig. 7 is a detail view showing an elevation of the clip and wire lever connected thereto.

Referring more particularly to the drawings, the head rest embodies an annular cup shaped member 1 usually made of metal which is bolted to the head rest frame 3 equipped with a shaft 4 that fits into the socket of the upper part of the dental chair, not shown. Cup shaped member 1 is provided with an annular lateral wall 5 open at the top to provide a chamber to allow for the disposition of rubber pad 10. The lateral wall 12 of pad 10 bulges somewhat at 15 adjacent the location of the upper edge 16 of member 1, whereby to aid in holding said pad 10 within member 1. Furthermore, pad 10 is made preferably of sponge rubber to effect a soft yield-

ing surface that is easy and comfortable for the head. Rubber pad 10 is held in member 1 in a detachable manner, whereby it can be removed at the will of the user for cleansing purposes or for replacement.

A sheet of paper or cover 20 is held in a removable manner over the outer exposed surface of rubber pad 10 by a rubber or metal band 21. Band 21 in turn is held in place adjacent the head rest by a spring clip 22. Clip 22 is made from a single piece of spring metal. It is doubled back upon itself at each end, as at 25 and 26. Part 25 is slipped through a slot 27 in wall 5 of member 1 and parallels the inner surface of said wall 5 when in correct position. The parts 30, 30 of member 25 are projected through corresponding openings 31, 31 in wall 5, whereby to hold clip 22 in assembled position with respect to wall 5. The upper part 26 of clip 22 terminates in coils 35, 35 disposed at each end for mounting a releasing member or lever 40. Member 40 is made of wire and is bent at an angle at 41, 41, to allow the lower free end to project beneath the lower surface of cup 1, in order to be cut out of the way. Moreover, the bent portions at 41 will be opposite the lower edge 42 of cup 1, whereby said edge will serve as a fulcrum against which wire member 40 acting as a lever can be rocked to throw the upper portion 26 of clip 22 away from the surface of wall 5 to release paper cover 20 caught between the outer surface of wall 5 and the inner surface of part 26. Part 26 is held yielding against wall 5 by the spring tendency inherent in portion 45 of clip 22. Furthermore, rubber or metal band 21 is held to clip 22 by the upper doubled back part 26 just above coils 35, 35. Opposite the location of clip 22, wall 5 is indented outward to form a stop 23 to hold band 21 from slipping upwards when in paper holding position.

In operation, assuming the head rest in position on a dental chair, not shown, rubber pad 10 which has been cleaned or renewed will be inserted in cup member 1 and there left more or less permanently. A sheet of paper or napkin 20 will be placed over the upper surface of pad 10. Its peripheral edge

will be caught at one portion between wall 5 and portion 26 of clip 22. For this purpose, the lower part of wire lever 40 will be pushed inward to move the upper part of clip 5 22 outward and away from the wall 5 of cup member 1. After the insertion of the edge of the paper 20 the upper part 26 will spring back of its own volition under influence of the spring tendency in part 45 of said clip 10 22. Rubber band 21 will be stretched then about the wall 5 of cup 1 and below projection 23 whereby to hold the edge of paper 20 tightly against the outer surface of wall 5. A new sheet of paper 20 can be substituted 15 easily after each occupant leaves the chair, not shown, and before the next person enters the same by simply manipulating band 21 and clip 22 as above described.

Having thus described my invention what 20 I claim is new and desire to secure by Letters Patent is as follows:

1. In a head rest, a support, a removable sponge rubber cushion mounted in said support, a removable cover mounted on said 25 cushion, a ring surrounding said support, whereby to hold said removable cover on said cushion, a spring clip mounted on said support and hooked onto said ring, and a lever carried by said clip and bearing against the 30 support adapted to move said clip, whereby to release the removable cover.

2. In a head rest, a support, a removable rubber cushion mounted in said support, a removable cover mounted on said cushion, a 35 ring surrounding said support, whereby to hold said removable cover on said cushion, a spring clip mounted on said support and hooked onto said ring, and a lever carried by said clip and bearing against the support 40 adapted to move said clip, whereby to release the removable cover.

In testimony whereof I have affixed my signature.

WILLIAM J. HEINTZ.

45

50

55

60

65