



- (51) International Patent Classification:
B65D 85/10 (2006.01)
- (21) International Application Number:
PCT/IB2015/055204
- (22) International Filing Date:
9 July 2015 (09.07.2015)
- (25) Filing Language:
Italian
- (26) Publication Language:
English
- (30) Priority Data:
BO2014A000390 10 July 2014 (10.07.2014) IT
- (71) Applicant: **G.D SOCIETA' PER AZIONI** [IT/IT]; Via Battindarno, 91, I-40133 Bologna (IT).
- (72) Inventors: **MADERA, Giovanni**; Viale Masini, 40, I-40126 Bologna (IT). **ROMAGNOLI, Stefano**; Via Carracci, 15, I-40033 Casalecchio Di Reno (IT). **NEGRINI, Stefano**; Via Longarola, 21, I-40012 Calderara Di Reno (IT).
- (74) Agents: **MACCAGNAN, Matteo** et al.; STUDIO TORTA S.p.A., Via Viotti, 9, I-10121 Torino (IT).

- (81) Designated States (unless otherwise indicated, for every kind of national protection available): AE, AG, AL, AM, AO, AT, AU, AZ, BA, BB, BG, BH, BN, BR, BW, BY, BZ, CA, CH, CL, CN, CO, CR, CU, CZ, DE, DK, DM, DO, DZ, EC, EE, EG, ES, FI, GB, GD, GE, GH, GM, GT, HN, HR, HU, ID, IL, IN, IR, IS, JP, KE, KG, KN, KP, KR, KZ, LA, LC, LK, LR, LS, LU, LY, MA, MD, ME, MG, MK, MN, MW, MX, MY, MZ, NA, NG, NI, NO, NZ, OM, PA, PE, PG, PH, PL, PT, QA, RO, RS, RU, RW, SA, SC, SD, SE, SG, SK, SL, SM, ST, SV, SY, TH, TJ, TM, TN, TR, TT, TZ, UA, UG, US, UZ, VC, VN, ZA, ZM, ZW.
- (84) Designated States (unless otherwise indicated, for every kind of regional protection available): ARIPO (BW, GH, GM, KE, LR, LS, MW, MZ, NA, RW, SD, SL, ST, SZ, TZ, UG, ZM, ZW), Eurasian (AM, AZ, BY, KG, KZ, RU, TJ, TM), European (AL, AT, BE, BG, CH, CY, CZ, DE, DK, EE, ES, FI, FR, GB, GR, HR, HU, IE, IS, IT, LT, LU, LV, MC, MK, MT, NL, NO, PL, PT, RO, RS, SE, SI, SK, SM, TR), OAPI (BF, BJ, CF, CG, CI, CM, GA, GN, GQ, GW, KM, ML, MR, NE, SN, TD, TG).

Published:
— with international search report (Art. 21(3))

(54) Title: SOFT PACKET OF CIGARETTES PROVIDED WITH A CLOSING STAMP

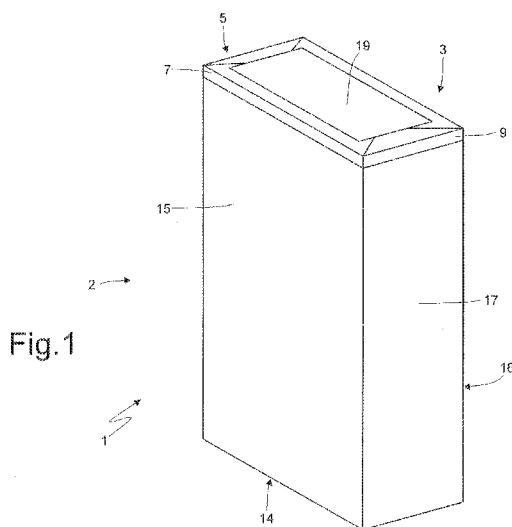

(57) Abstract: A soft packet (1) of cigarettes having: a group (4) of cigarettes; an inner package (3) enclosing the group (4) of cigarettes and has a top wall (5); an outer package (2), surrounding the inner package (3) on five sides leaving the top wall (5) of the inner package (3) exposed; and a sealing stamp (19) superimposed on the top wall (5) of the inner package (3), is only and entirely superimposed on the top wall (5) of the inner package (3), touches no part of the outer package (2), and is glued to the top wall (5) of the inner package (3) by way of glue (20).



"SOFT PACKET OF CIGARETTES PROVIDED WITH A CLOSING STAMP"TECHNICAL FIELD

The present invention relates to a soft packet of cigarettes
5 provided with a closing stamp.

PRIOR ART

A soft packet of cigarettes currently on the market (for
example of the type described in the patent application
10 EP1813552A1) comprises an inner package of metal foil entirely
wrapping a group of cigarettes, and a cup-shaped outer package
that is formed by soft packing material, and encloses the
inner package on five sides leaving the top wall (or head) of
the inner package exposed. Furthermore, the soft packet of
15 cigarettes comprises a sealing stamp (also typically having
tax purposes, i.e. payment proof of a government tax), which
is glued to the outer package, U-folded and arranged astride
the top wall (or head) of the inner package in order to rest
its own central portion onto the top wall (or head) of the
20 inner package. The inner package is normally entirely devoid
of glue, and therefore is kept closed and inside the outer
package by the closing stamp which also has the function of
stabilizing and retaining the inner package.

25 For withdrawing the cigarettes, the smoker, at the opening of
the packet of cigarettes for the first time, must tear off a
portion of the top wall of the inner package left uncovered by
the closing stamp (i.e. the smoker tears off the top wall of
the inner package next to the closing stamp).

30
In a soft packet of cigarettes currently on the market of the
type described above, the closing stamp has relatively
relevant sizes, and therefore for the production thereof it is
necessary to use a quantity of packing material relatively
35 high with a consequent non-negligible impact both on
production costs of the new packet of cigarettes and on

disposal costs of the used packet of cigarettes.

The patent US3809227 describes a group of five packets 10 of cigarettes, each of which comprises a group 64 of cigarettes wrapped inside two sheets 60 and 62 of packing material and further surrounded by an overwrapping 66 of transparent plastic material (cellophane). Over the top wall 66 of the overwrappings 66 of transparent plastic material a strip 12 is fixed (by heat sealing or by gluing), which has the function to provide both a mechanical connection between the five packets 10 of cigarettes, and a tax function (i.e. constituting proof of a fee payment).

DESCRIPTION OF THE INVENTION

The object of the present invention is to provide a soft packet of cigarettes provided with a closing stamp, wherein said packet of cigarettes is free from the drawbacks described above and, at the same time, easy and inexpensive to produce. According to the present invention, a soft packet of cigarettes provided with a sealing stamp, as claimed in the attached claims is provided.

BRIEF DESCRIPTION OF DRAWINGS

The present invention will now be described with reference to the accompanying drawings, which illustrate some examples of non-limiting embodiments, wherein:

- Figure 1 is a front perspective view of a soft packet of cigarettes produced according to the present invention;
- Figure 2 is a front perspective view of a group of cigarettes contained inside the packet of cigarettes of Figure 1;
- Figure 3 is a front perspective view of an inner package of the packet of cigarettes of Figure 1;
- Figure 4 is a front perspective view of an outer package of the packet of cigarettes of Figure 1;
- Figure 5 is a front perspective view of the packet of

cigarettes of Figure 1 devoid of a sealing stamp;

- Figure 6 is a view of a sheet of packing material used to produce the inner package of Figure 3;

- Figure 7 is a view of a further embodiment of a sheet of packing material used to produce the inner package of Figure 3; and

- Figure 8 is a view of a sheet of packing material used to produce the outer package of Figure 4.

10 PREFERRED EMBODIMENTS OF THE INVENTION

In Figure 1, number 1 indicates as a whole a soft packet of cigarettes. The packet 1 of cigarettes comprises a cup-shaped outer package 2 (shown alone in Figure 4) made of a soft packing material and an inner package 3 (illustrated as a whole in Figure 3) which is housed inside the outer package 2 and surrounds a parallelepiped-shaped group 4 of cigarettes (shown in Figure 2).

As shown in Figure 3, the inner package 3 is parallelepiped-shaped and has an top wall 5 and a bottom wall 6 opposite and parallel to each other, a front wall 7 and a rear wall 8 opposite and parallel to each other, and two lateral walls 9 opposite and parallel to each other.

25 The inner package 3 is made by folding a sheet of packing material 10 (illustrated in Figures 6 and 7 in two different embodiments alternative to each other) of metal foil about a group 4 of cigarettes. During the folding of the sheet 10 of packing material illustrated in Figure 6 a longitudinal overlapping between two opposite flaps of the sheet 10 of packing material is obtained at a lateral wall 9 of the inner package 3 and two folds at the top (i.e. folds that close the open ends of a tubular package) are obtained at the top wall 5 and bottom wall 6. During the folding of the sheet 10 of packing material illustrated in Figure 7 a longitudinal overlapping between two opposite flaps of the sheet 10 of

packing material is provided at each lateral wall 9 of the inner package 3 and a fold at the top (i.e. a fold that closes an open end of a tubular package) is obtained at the top wall 5. Accordingly, the top wall 5 of the inner package 3 comprises a rear fold flap 12 which is folded partially about the group 4 of cigarettes and a front fold flap 11 which is folded partially over the rear fold flap 12; the front fold flap 11 is trapezoidal-shaped with its long sides coincident with a top edge of the front wall 7, while the rear fold flap 12 is trapezoidal-shaped with its long sides coincident with a top edge of the rear wall 8.

As shown in Figure 4, the outer package 2 is parallelepiped-shaped and has an open top end 13 and a bottom wall 14 opposite and parallel to each other, a front wall 15 and a rear wall 16 opposite and parallel to each other, and two lateral walls 17 opposite and parallel to each other. Basically, the outer package 2 surrounds on five sides, the inner package 3 leaving the top wall 5 of the inner package 3 exposed. The outer package 2 is formed by folding a sheet of packing material 18 (shown in Figure 8) about the inner package 3; during the folding of the sheet of packing material 18 a longitudinal overlapping between the two opposite ends of the sheet 18 of packing material at a lateral wall 17 of the outer package 2 is obtained and a folding at the top (i.e. a fold which closes an open end of a tubular package) is obtained at the bottom wall 14 of the outer package 2.

Finally, as illustrated in Figure 1, the packet 1 of cigarettes comprises a sealing stamp 19, which also can have (but may also be without) a tax function, i.e. payment proof of a government tax. The sealing stamp 19 is only and entirely superimposed on the top wall 5 of the inner package 3 and touches no part of the outer package 2. In other words, the sealing stamp 19 is flat and rectangular (i.e., the sealing stamp 19 is entirely flat and is devoid of any type of fold)

and is superimposed only on the top wall 5 of the inner package 3, touching no other part of the inner package 3, and touching no part whatsoever of the outer package 2. In particular, the sealing stamp 19 is located symmetrically in the center of the top wall 5 of the inner package 3 and is superimposed on both the front fold flap 11, and the back fold flap 12 of the top wall 5 of the inner package 3 (as best illustrated in Figure 5).

10 According to a preferred (but not binding) embodiment illustrated in the attached figures, the sealing stamp 19 is rectangular with its long sides parallel to the top edge of the front wall 7 of the inner package 3 (and therefore also parallel to the top edge of the rear wall 8 of the inner
15 package 3) and its short sides parallel to the top edges of the lateral walls 9 of the inner package 3. In addition, according to a preferred (but not binding) embodiment, the sealing stamp 19 has an overall size (i.e. an area) smaller than the size (area) of the top wall 5 of the inner package 3.

20

As shown in Figure 5, the sealing stamp 19 is glued to the top wall 5 of the inner package 3 by means of glue 20; preferably, the glue 20 is applied to a lower face of the sealing stamp 19 before applying the sealing stamp 19 to the top wall 5 of the
25 inner package 3 (i.e. the sealing stamp 19 is rubber-coated before applying the sealing stamp 19 to the top wall 5 of the inner package 3). The glue 20 is interposed between the sealing stamp 19 and the top wall 5 of the inner package 3 so as to be arranged both at the front fold flap 11 of the top
30 wall 5, and at the rear fold flap 12 of the top wall 5. In other words, the sealing stamp 19 is glued by means of the glue 20 to both the fold flaps 11 and 12 of the top wall 5.

As shown in Figure 8, between the outer package 2 and the
35 inner package 3 glue 21 is interposed, i.e. an inner face of the outer package 2 is glued to an outer face of the inner

package 3 by means of glue 21. According to a preferred (but not binding) embodiment illustrated in Figure 8, the glue 21 is interposed between the front wall 7 of the inner package 3 and the front wall 15 of the outer package 2 and the glue 21 is interposed between the rear wall 8 of the inner package 3 and the rear wall 16 of the outer package 2. Preferably, the glue 21 is located in the vicinity of the open top end 13 of the outer package 2, i.e. in the vicinity of the top wall 5 of the inner package 3 (that is at a top edge of the outer package 2). The function of the glue 21 is to make the inner package 3 integral with the outer package 2 so as to avoid that in use the inner package 3 can slide axially with respect to the outer package 2 (i.e., so as to avoid that in use the inner package 3 might axially slide away from the outer package 2).

As shown in Figure 8, the outer package 2 is provided with further glue 22 that has the function of stabilizing the shape of the outer package 2; in other words, the glue 22 keeps in contact with each other superimposed portions of the sheet 18 of packing material at the bottom wall 14 of the outer package 2 and at a lateral wall 17 of the outer package 2 to stabilize the shape of the outer package 2.

As shown in Figures 3, 6 and 7, the inner package 3, is provided with glue 23 having the function of stabilizing the shape of the inner package 3 at the top wall 5; in other words, the glue 23 only stabilizes the folds of the top wall 5 of the inner package 3. In particular, the glue 23 is located between the two fold flaps 11 and 12 of the top wall 5 of the inner package 3, to stabilize the shape of the inner package 3 at the top wall 5. The function of the glue 23 is to stabilize the shape of the inner package 3 at the top wall 5 so as to simplify applying the sealing stamp 19: thanks to the glue 23, the top wall 5 of the inner package 3 is (sufficiently) stable and then the sealing stamp 19 can be applied without having to

simultaneously hold the top wall 5 itself.

It is important to note that in the finished packet 1 of cigarettes, the shape of the inner package 3 at the top wall 5 is stabilized both by the glue 23, and by the sealing stamp 19 which is glued to the top wall 5 by means of the glue 20; accordingly, it is sufficient that the glue 23 provides a limited stabilization of the top wall 5 of the inner package 3 until the application of the sealing stamp 19, and therefore the glue 23 is generally little and affects a limited portion of the top wall 5.

Normally, the packet 1 of cigarettes comprising an overwrapping of transparent plastic material (cellophane) which is wrapped around the outer package 2, is stabilized by heat sealing, and has a tear-off strip. Clearly, the sealing stamp 19 is located inside the overwrapping of transparent plastic material and has no connection to the overwrapping of transparent plastic material (i.e. is not in any way glued or otherwise connected to the overwrapping of transparent plastic material).

The packet 1 of cigarettes described above has numerous advantages.

First, in the packet 1 of cigarettes described above, the sealing stamp 19 has a reduced size resulting in a significant reduction of the packing material used to produce the sealing stamp 19; indicatively, the sealing stamp 19 of the packet 1 of cigarettes described above is of a size that is roughly half the size of a similar sealing stamp of a packet of cigarettes currently on the market.

Furthermore, the packet 1 of cigarettes described above is also easy to manufacture as it can be produced in a substantially standard cigarette packing machine; i.e. changes

to be made to a cigarette packing machine to produce the standard packet 1 of cigarettes described above are contained and substantially trivial. In particular, to adapt a standard cigarette packing machine for producing the packet 1 of 5 cigarettes described above it is sufficient to: change the size and orientation in feeding the sealing stamp, add a gumming device for applying glue 23 to the sheets 10 of packing material, and change the gumming device gumming the sheets 18 of packing material to apply in addition to the glue 10 22 also the glue 21.

CLAIMS

1) A soft packet (1) of cigarettes comprising:
a group (4) of cigarettes;
5 an inner package (3) enclosing the group (4) of cigarettes and
having a top wall (5);
an outer package (2), surrounding the inner package (3) on
five sides leaving the top wall (5) of the inner package (3)
exposed; and
10 a sealing stamp (19) superimposed on the top wall (5) of the
inner package (3);
the packet (1) being **characterized in that:**
the sealing stamp (19) is only and entirely superimposed on
the top wall (5) of the inner package (3) and touches no part
15 of the outer package (2); and
the closing stamp (19) is glued to the top wall (5) of the
inner package (3) by a first glue (20).

2) The packet (1) of cigarettes according to Claim 1, wherein:
20 the top wall (5) of the inner package (3) comprises two
trapezoidal-shaped, at least partially overlapping fold flaps
(11, 12); and
the first glue (20) is interposed between the sealing stamp
(19) and the top wall (5) of the inner package (3), so as to
25 be located at both fold flaps (11, 12) of the top wall (5) of
the inner package (3).

3) The packet (1) of cigarettes according to Claim 1 or 2,
wherein a second glue (21) is interposed between the outer
30 package (2) and the inner package (3) to connect the inner
package (3) integrally to the outer package (2).

4) The packet (1) of cigarettes according to claim 3, wherein
the second glue (21) is interposed between a front wall (7) of
35 the inner package (3) and a front wall (15) of the outer
package (2), and between a rear wall (8) of the inner package

(3) and a rear wall (16) of the outer package (2).

5) The packet (1) of cigarettes according to Claim 4, wherein the second glue (21) is located at a top edge of the outer
5 package (2).

6) The packet (1) of cigarettes according to one of Claims 1 to 5, wherein the sealing stamp (19) is flat and rectangular, is only superimposed on the top wall (5) of the inner package
10 (3), touches no other part of the inner package (3), and touches no part whatsoever of the outer package (2).

7) The packet (1) of cigarettes according to one of Claims 1 to 6, wherein the sealing stamp (19) is rectangular, with its
15 long sides parallel to the top edges of a front wall (7) and a rear wall (8) of the inner package (3), and its short sides parallel to the top edges of lateral walls (9) of the inner package (3).

20 8) The packet (1) of cigarettes according to one of Claims 1 to 7, wherein the sealing stamp (19) as a whole is smaller than the top wall (5) of the inner package (3).

9) The packet (1) of cigarettes according to one of Claims 1
25 to 8, wherein:

the top wall (5) of the inner package (3) comprises two trapezoidal-shaped, at least partially overlapping fold flaps (11, 12); and

30 the sealing stamp (19) is located symmetrically in the center of the top wall (5) of the inner package (3), and is superimposed on both the fold flaps (11, 12) of the top wall (5) of the inner package (3).

10) The packet (1) of cigarettes according to one of Claims 1
35 to 9, wherein the inner package (3) has a third glue (23) for stabilizing the shape of the inner package (3) at the top wall

(5) only.

11) The packet (1) of cigarettes according to claim 10, wherein:

5 the top wall (5) of the inner package (3) comprises two trapezoidal-shaped, at least partially overlapping fold flaps (11, 12); and

the third glue (23) is located between the two fold flaps (11, 12) of the top wall (5) of the inner package (3), to stabilize
10 the shape of the inner package (3) at the top wall (5).

12) The packet (1) of cigarettes according to one of Claims 1 to 11, wherein:

the inner package (3) is formed by folding a first sheet (10) of packing material about the group (4) of cigarettes; and
15

the outer package (2) is formed by folding a second sheet (18) of packing material separate and independent from the first sheet (10) of packing material about the inner package (3).

20 13) The packet (1) of cigarettes according to one of Claims 1 to 12 and comprising an overwrapping of transparent plastic material enclosing the outer package (2).

14) The packet (1) of cigarettes according to Claim 13, wherein the sealing stamp (19) is arranged inside the
25 overwrapping of transparent plastic material and has no connection with the overwrapping of transparent plastic material itself.

30

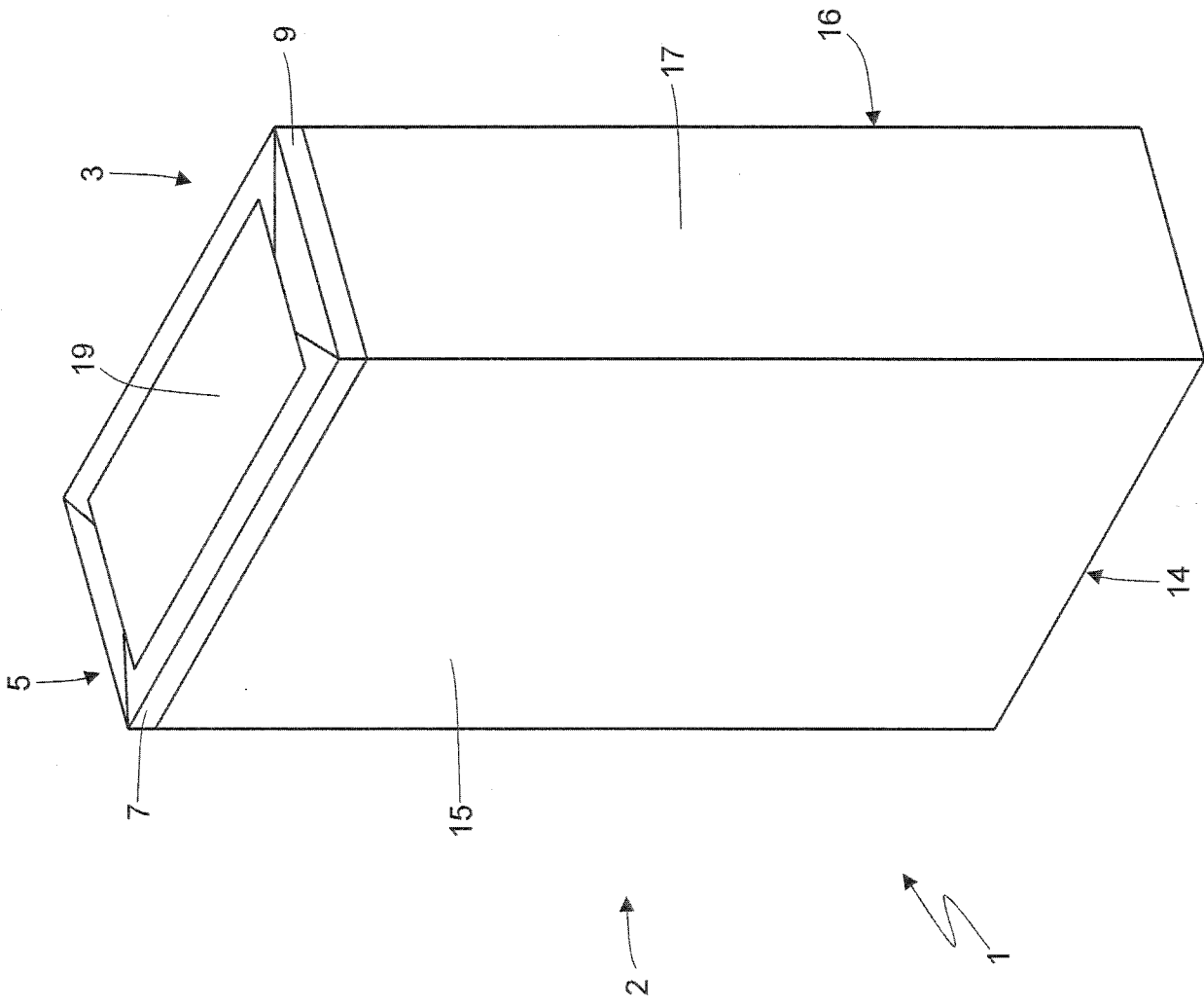

Fig.1

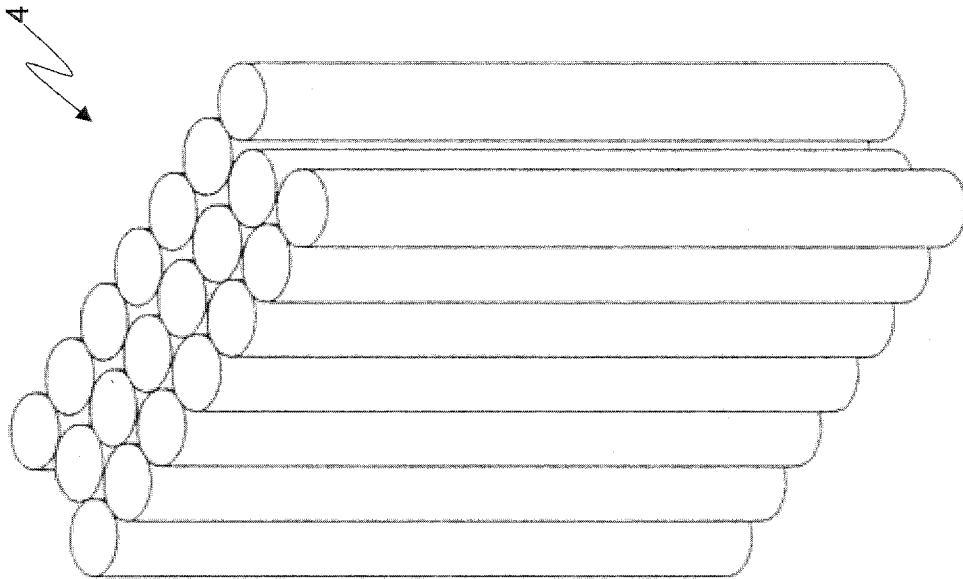

Fig.2

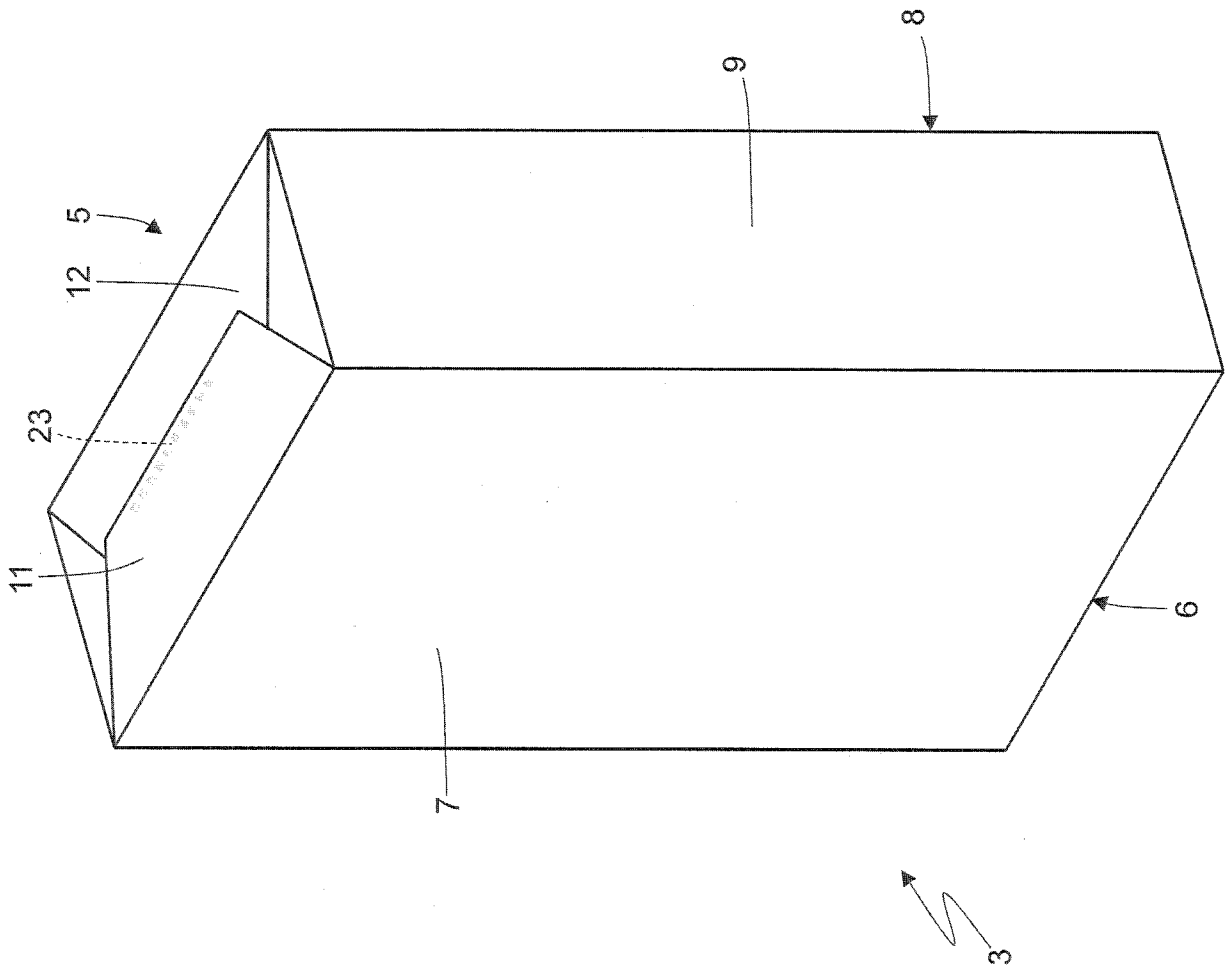

Fig.3

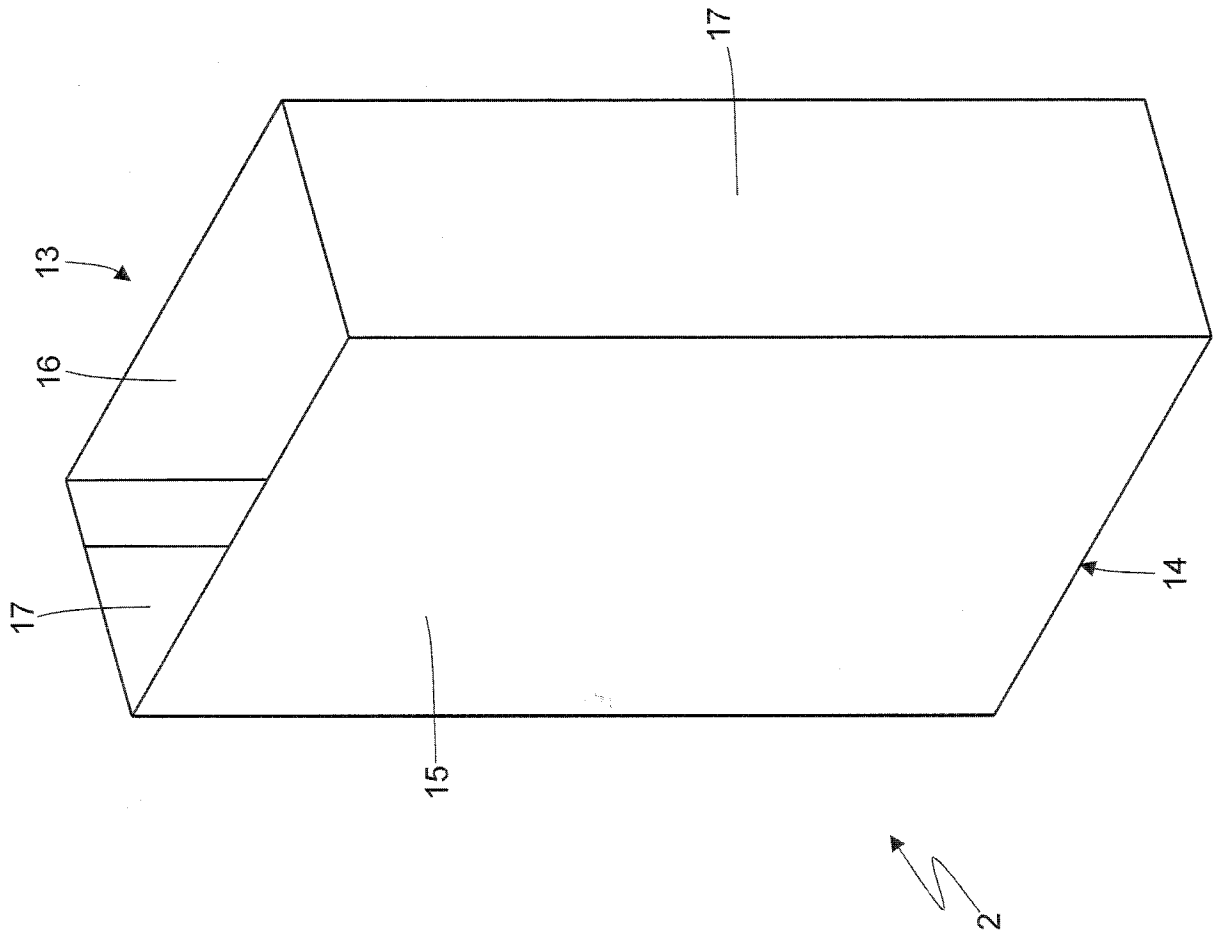

Fig.4

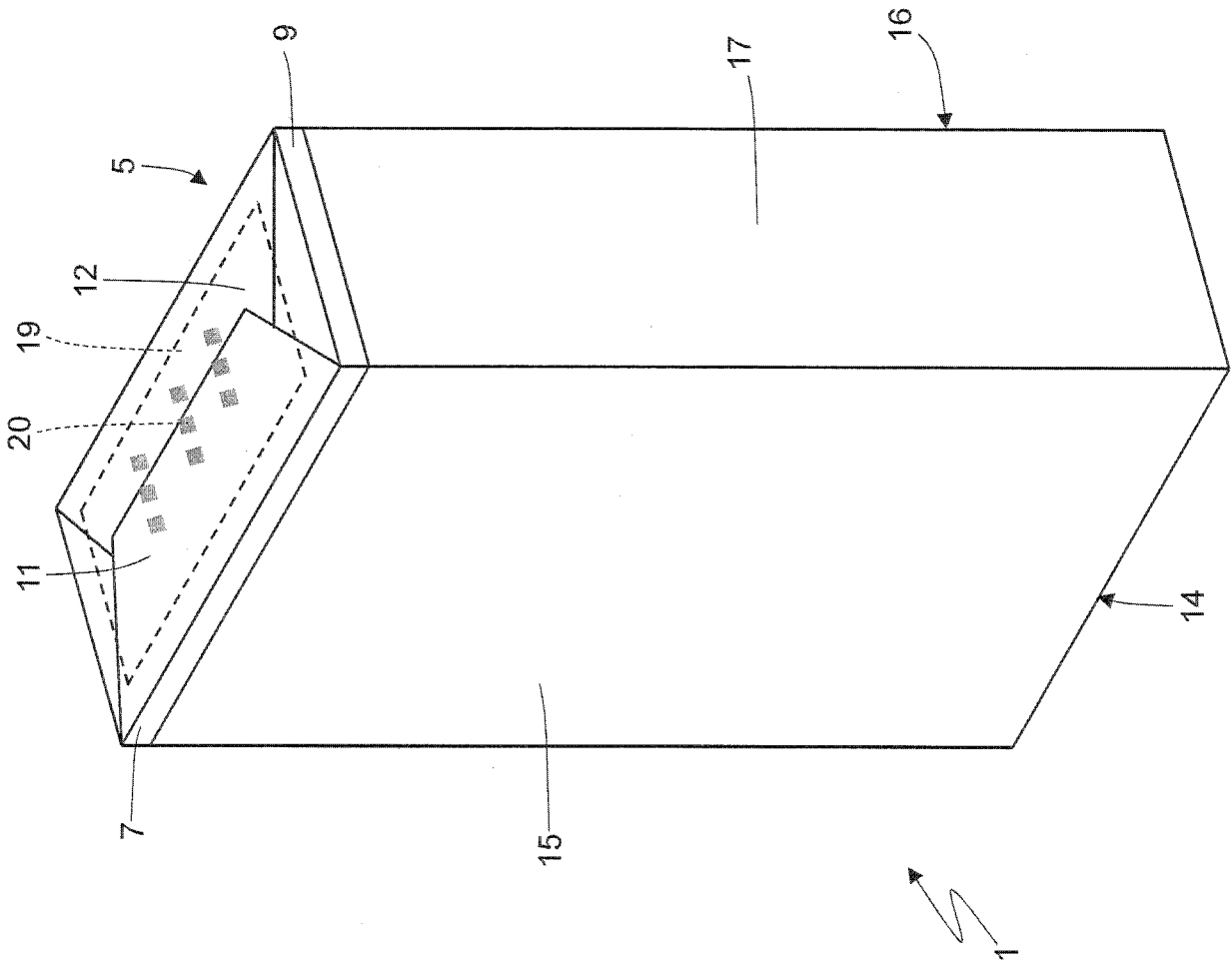

Fig.5

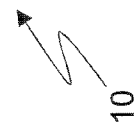
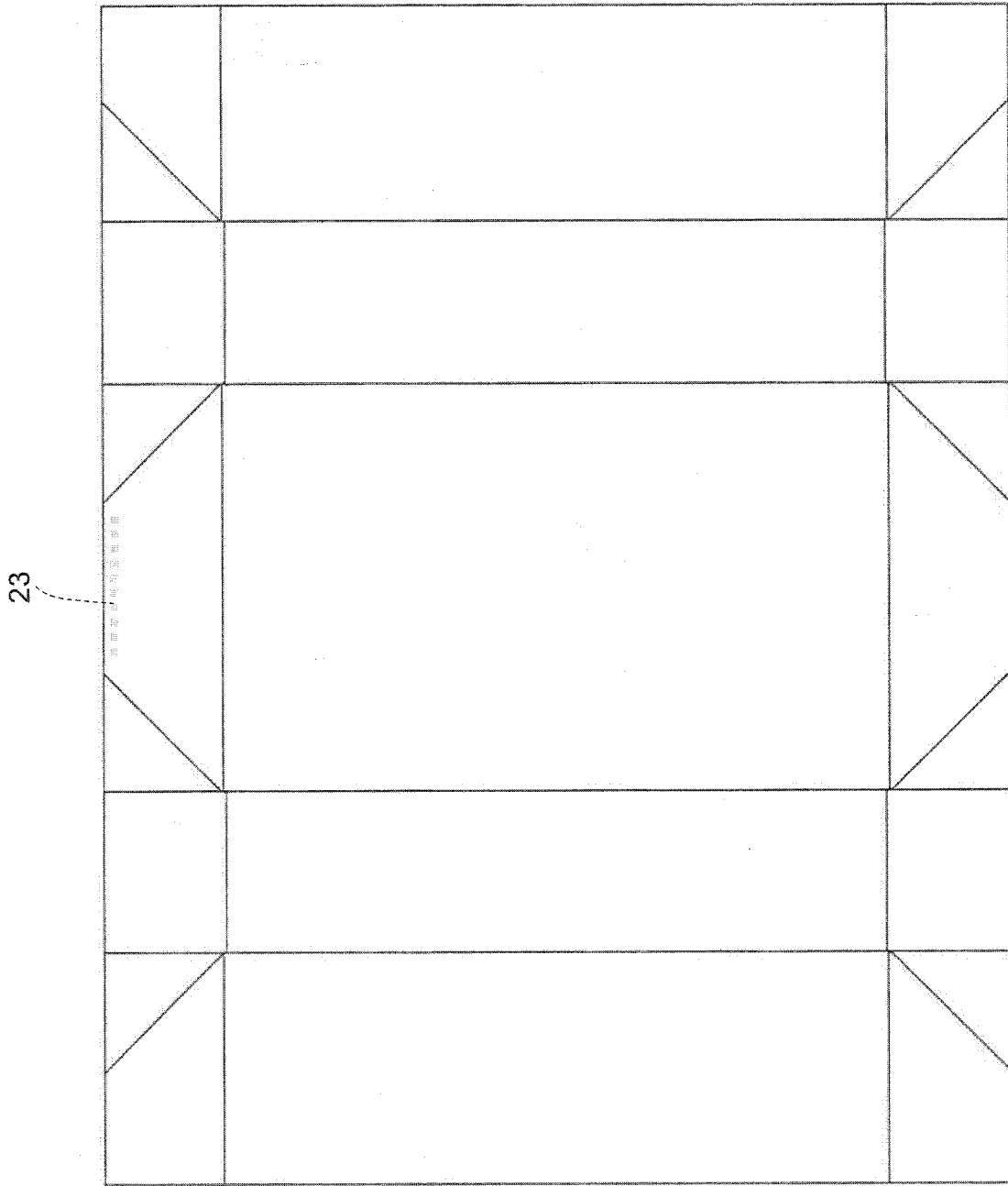

Fig.6

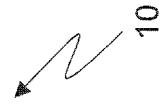
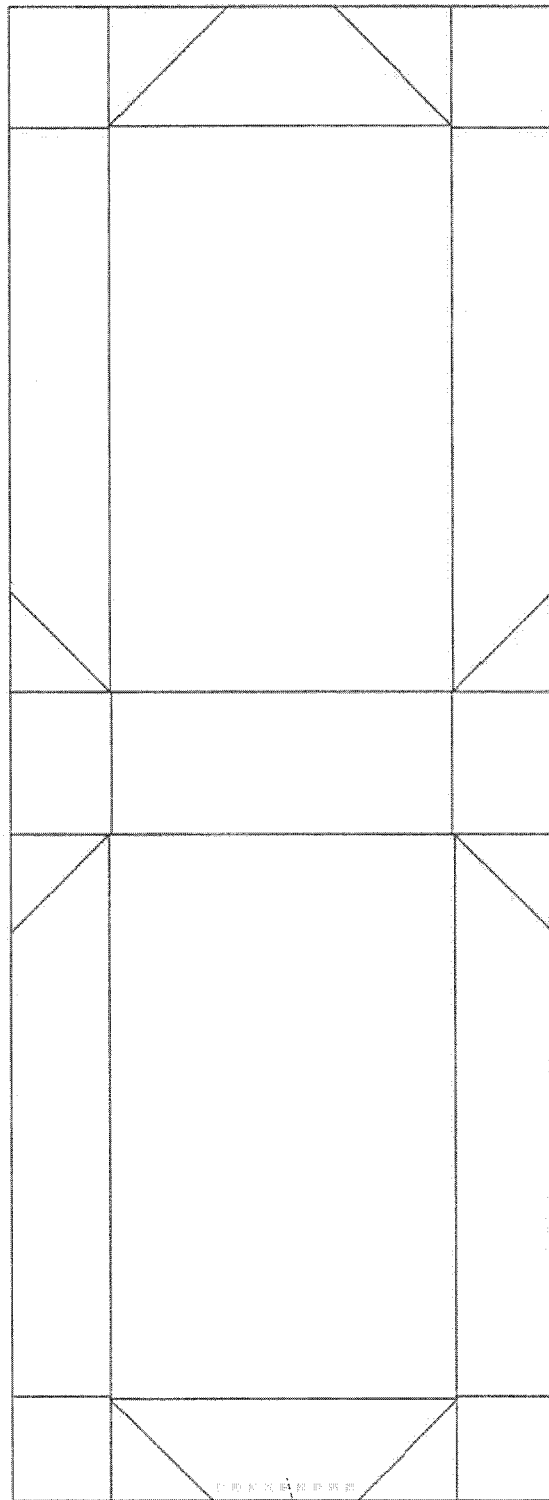

Fig.7

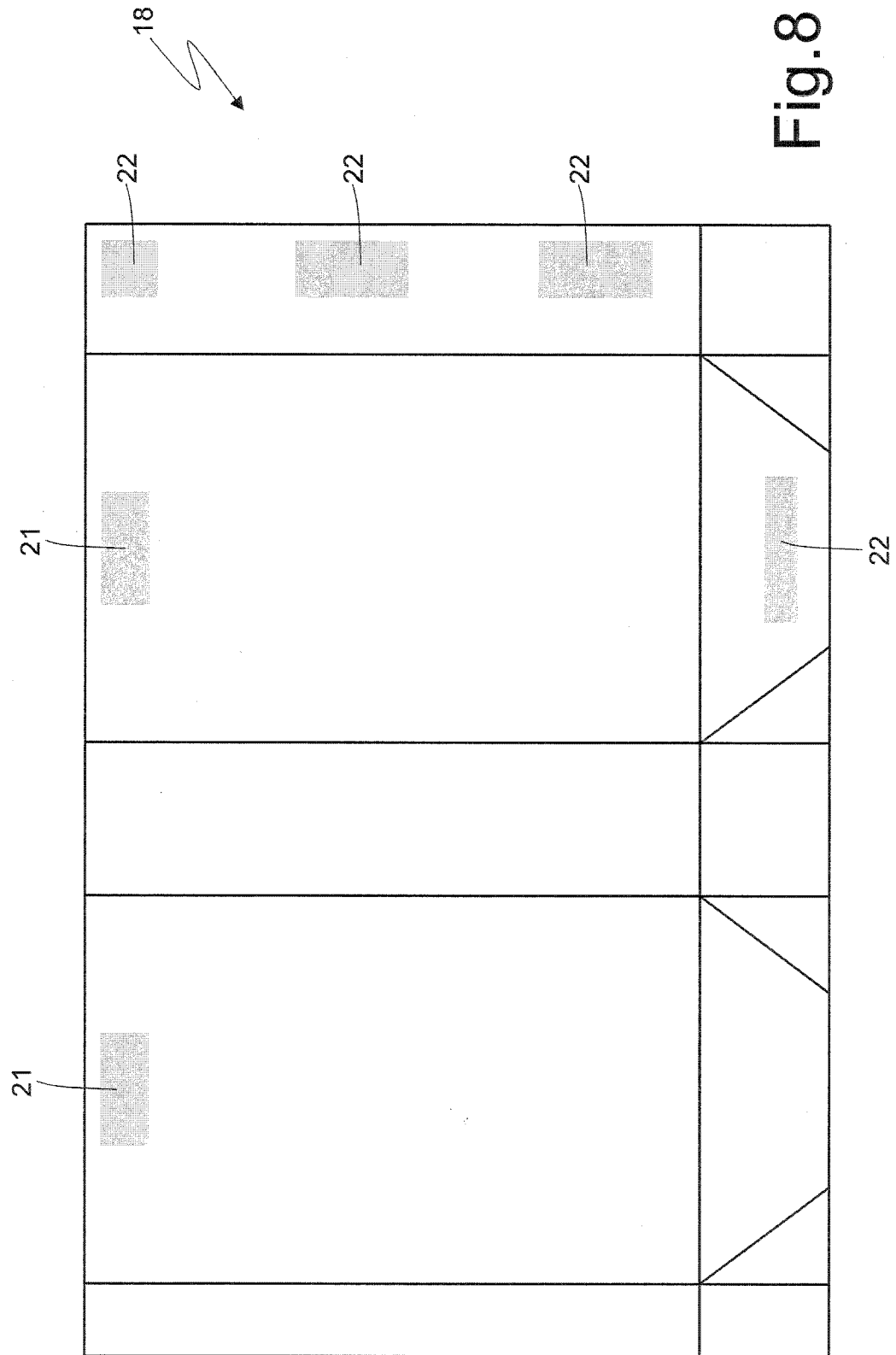

Fig. 8

INTERNATIONAL SEARCH REPORT

International application No PCT/IB2015/055204
--

A. CLASSIFICATION OF SUBJECT MATTER
INV. B65D85/10
ADD.

According to International Patent Classification (IPC) or to both national classification and IPC

B. FIELDS SEARCHED

Minimum documentation searched (classification system followed by classification symbols)
B65D

Documentation searched other than minimum documentation to the extent that such documents are included in the fields searched

Electronic data base consulted during the international search (name of data base and, where practicable, search terms used)
EPO-Internal, WPI Data

C. DOCUMENTS CONSIDERED TO BE RELEVANT

Category*	Citation of document, with indication, where appropriate, of the relevant passages	Relevant to claim No.
Y	EP 1 813 552 A1 (JAPAN TOBACCO INC [JP]) 1 August 2007 (2007-08-01) paragraph [0015] - paragraph [0022] figures 1-13	1-14
Y	-----	
Y	US 3 809 227 A (BEGEMANN C) 7 May 1974 (1974-05-07) column 3, line 14 - column 4, line 13 figures 1-6	1-14
Y	-----	
Y	GB 2 260 757 A (GD SPA [IT]) 28 April 1993 (1993-04-28) page 5, line 13 - page 8, line 20 figures 1-5	3-5
A		1,2,6-14
Y	-----	
Y	EP 2 006 214 A1 (PHILIP MORRIS PROD [CH]) 24 December 2008 (2008-12-24) paragraph [0025]	10,11
A	figure 3	1-9, 12-14

Further documents are listed in the continuation of Box C. See patent family annex.

* Special categories of cited documents :

<p>"A" document defining the general state of the art which is not considered to be of particular relevance</p> <p>"E" earlier application or patent but published on or after the international filing date</p> <p>"L" document which may throw doubts on priority claim(s) or which is cited to establish the publication date of another citation or other special reason (as specified)</p> <p>"O" document referring to an oral disclosure, use, exhibition or other means</p> <p>"P" document published prior to the international filing date but later than the priority date claimed</p>	<p>"T" later document published after the international filing date or priority date and not in conflict with the application but cited to understand the principle or theory underlying the invention</p> <p>"X" document of particular relevance; the claimed invention cannot be considered novel or cannot be considered to involve an inventive step when the document is taken alone</p> <p>"Y" document of particular relevance; the claimed invention cannot be considered to involve an inventive step when the document is combined with one or more other such documents, such combination being obvious to a person skilled in the art</p> <p>"&" document member of the same patent family</p>
---	---

Date of the actual completion of the international search 7 October 2015	Date of mailing of the international search report 15/10/2015
--	---

Name and mailing address of the ISA/ European Patent Office, P.B. 5818 Patentlaan 2 NL - 2280 HV Rijswijk Tel. (+31-70) 340-2040, Fax: (+31-70) 340-3016	Authorized officer Weyand, Tim
--	--

INTERNATIONAL SEARCH REPORT

Information on patent family members

International application No PCT/IB2015/055204

Patent document cited in search report	Publication date	Publication date	Patent family member(s)	Publication date
EP 1813552	A1	01-08-2007	CA 2586671 A1	26-05-2006
			CN 101102944 A	09-01-2008
			EP 1813552 A1	01-08-2007
			ES 2492566 T3	09-09-2014
			HK 1107967 A1	04-05-2012
			JP 4697891 B2	08-06-2011
			KR 20070063588 A	19-06-2007
			RU 2355617 C2	20-05-2009
			TW 1277394 B	01-04-2007
			UA 89511 C2	10-02-2010
			US 2007284268 A1	13-12-2007
			WO 2006054482 A1	26-05-2006
US 3809227	A	07-05-1974	SU 505342 A3	28-02-1976
			US 3809227 A	07-05-1974
			ZA 7307843 A	28-08-1974
GB 2260757	A	28-04-1993	DE 4235439 A1	29-04-1993
			GB 2260757 A	28-04-1993
			IT 1253224 B	11-07-1995
EP 2006214	A1	24-12-2008	EP 2006214 A1	24-12-2008
			US 2008308432 A1	18-12-2008