

(12) STANDARD PATENT
(19) AUSTRALIAN PATENT OFFICE

(11) Application No. **AU 2002339370 B2**

(54) Title
Nasal Spray

(51) International Patent Classification(s)
A61H 33/04 (2006.01) **A61M 3/02** (2006.01)
A61H 35/04 (2006.01)

(21) Application No: **2002339370** (22) Date of Filing: **2002.10.16**

(87) WIPO No: **WO03/034973**

(30) Priority Data

(31) Number	(32) Date	(33) Country
101 51 676.2	2001.10.19	DE

(43) Publication Date: **2003.05.06**

(43) Publication Journal Date: **2003.07.03**

(44) Accepted Journal Date: **2007.07.19**

(71) Applicant(s)
Siemens & Co. Heilwasser Und Quellenprodukte Des Staatsbades Bad Ems GmbH & Co. KG

(72) Inventor(s)
Philipps, Tom;Karow, Eva-Maria;Weber, Klaus;Hirsch, Olaf

(74) Agent / Attorney
Watermark Patent & Trademark Attorneys, Level 2 302 Burwood Road, Hawthorn, VIC, 3122

(56) Related Art
US 6793104
US 5505193
DE 3332723
US 3089626
US 3542256
US 6736792
US 3847145
US 6484715
JP 10 017039
US 2005/0028812
US 2005/0133546
DE 3929964
US 3812853
US 6238377
US 2004/0231669

(12) NACH DEM VERTRAG ÜBER DIE INTERNATIONALE ZUSAMMENARBEIT AUF DEM GEBIET DES PATENTWESENS (PCT) VERÖFFENTLICHTE INTERNATIONALE ANMELDUNG

(19) Weltorganisation für geistiges Eigentum
Internationales Büro



(43) Internationales Veröffentlichungsdatum
1. Mai 2003 (01.05.2003)

PCT

(10) Internationale Veröffentlichungsnummer
WO 03/034973 A1

- (51) Internationale Patentklassifikation: **A61H 35/04**, (71) **Anmelder** (für alle Bestimmungsstaaten mit Ausnahme von US): **SIEMENS & CO. HEILWASSER UND QUELLENPRODUKTE DES STAATSBADES BAD EMS GMBH & CO. KG** [DE/DE]; Arzbacher Strasse 78, 56130 Bad Ems (DE).
- (21) Internationales Aktenzeichen: PCT/DE02/03913
- (22) Internationales Anmeldedatum: 16. Oktober 2002 (16.10.2002) (72) **Erfinder; und** (75) **Erfinder/Anmelder** (nur für US): **PHILIPPS, Tom** [DE/DE]; Trondheimstrasse 10, 64297 Darmstadt (DE). **WEBER, Klaus** [DE/DE]; St. Georg Strasse 17, 56291 Leiningen (DE). **HIRSCH, Olaf** [DE/DE]; Hohenzollernstrasse 138, 56068 Koblenz (DE). **KAROW, Eva-Maria** [DE/DE]; Gartenstrasse 28, 56412 Niedererbach (DE).
- (25) Einreichungssprache: Deutsch
- (26) Veröffentlichungssprache: Deutsch
- (30) Angaben zur Priorität: 101 51 676.2 19. Oktober 2001 (19.10.2001) DE (74) **Anwalt: PHILIPP, Matthias**; Boehmert & Boehmert, Hollerallee 32, 28209 Bremen (DE).

[Fortsetzung auf der nächsten Seite]

(54) Title: NASAL SPRAY

(54) Bezeichnung: NASENDUSCHE

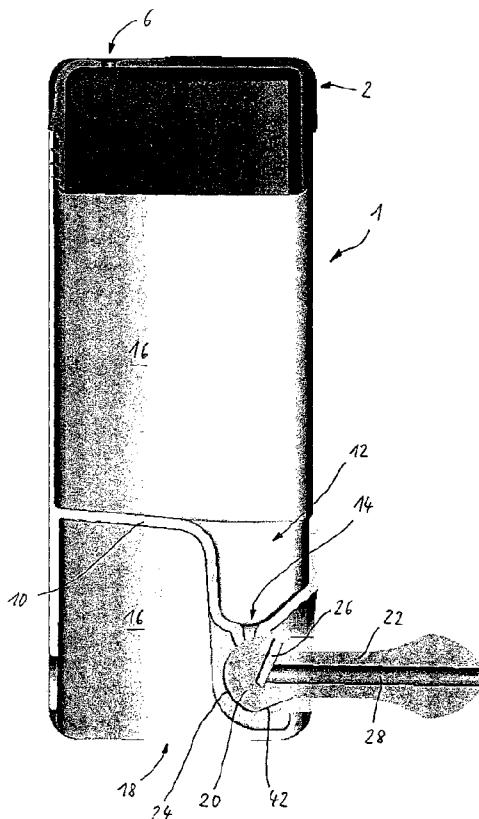

(57) **Abstract:** Nasal spray with a container for rinsing fluid, comprising an outlet opening, with a moving valve body mounted in the region of the outlet opening with a tube applied thereto. Various rotation positions of the valve body fix, in co-operation with the outlet opening, an open position (Fig. 2), in which the tube is connected to the container and a closed position (Fig. 1), in which the container is sealed. The valve body may be rotated into a ventilation position (Fig. 3), different from the closed and open positions in which the container may be emptied of any residue and ventilated.

(57) **Zusammenfassung:** Nasendusche mit einem Behälter für Spülflüssigkeit, der eine Austrittsöffnung aufweist, mit einem im Bereich der Austrittsöffnung beweglich gehaltenen Ventilkörper mit einem an diesem angesetzten Rohr, wobei unterschiedliche Schwenkpositionen des Ventilkörpers in Zusammenwirken mit der Austrittsöffnung eine Offenstellung (Fig. 2), in der das Rohr mit dem Behälter verbunden ist, und eine Schliessstellung (Fig. 1), in der der Behälter verschlossen ist, festlegen, wobei der Ventilkörper in eine von Offen- und Schliessstellung verschiedene Belüftungsstellung (Fig. 3), in der der Behälter restenleerbar und belüftet ist, schwenkbar ist.



WO 03/034973 A1



(81) **Bestimmungsstaaten** (*national*): AG, AL, AM, AT, AU, AZ, BA, BB, BG, BR, BY, BZ, CA, CH, CN, CO, CR, CU, CZ, DK, DM, DZ, EC, EE, ES, FI, GB, GD, GE, GH, GM, HR, HU, ID, IL, IN, IS, JP, KE, KG, KP, KR, KZ, LC, LK, LR, LS, LT, LU, LV, MA, MD, MG, MK, MN, MW, MX, MZ, NO, NZ, PH, PL, PT, RO, RU, SD, SE, SG, SI, SK, SI., TJ, TM, TN, TR, TT, TZ, UA, UG, US, UZ, VC, VN, YU, ZA, ZM, ZW.

eurasisches Patent (AM, AZ, BY, KG, KZ, MD, RU, TJ, TM), OAPI-Patent (BF, BJ, CF, CG, CI, CM, GA, GN, GQ, GW, ML, MR, NE, SN, TD, TG).

Veröffentlicht:

— mit internationalem Recherchenbericht

Zur Erklärung der Zweibuchstaben-Codes und der anderen Abkürzungen wird auf die Erklärungen ("Guidance Notes on Codes and Abbreviations") am Anfang jeder regulären Ausgabe der PCT-Gazette verwiesen.

(84) **Bestimmungsstaaten** (*regional*): ARIPO-Patent (GH, GM, KE, LS, MW, MZ, SD, SL, SZ, TZ, UG, ZM, ZW),

22 Jun 2007

2002339370

Nasal douche

5
0 The invention relates to a nasal douche with a container for rinsing fluid, which has a dispensing aperture, with a valve body kept movable in the region of the dispensing aperture with a tube attached to said valve body, such that different swivel positions of the valve body in co-operation with the dispensing aperture determine an open position, in which the tube is in communication with the container, and a closed position, in which the container is sealed, as is known from DE 39 29 964 C2.

5 The known nasal douche has proven very successful in practice, though it has occasionally turned out to be awkward in use, in that, once filled with rinsing fluid, the douche always has to be held in the hand, since the liquid runs out otherwise. Furthermore, the tube projecting from the container and/or the movable valve body could be damaged.

0 One object of the invention therefore consists in improving the known nasal douche such that it is easier to handle in use and damage to the valve body or the tube attached to it can be substantially ruled out.

This object is achieved, in accordance with the invention, by a nasal douche according to Claim 1. Useful further embodiments of the invention are shown in the dependent claims.

25 The invention will now be explained in the light of a working embodiment, reference being made to a drawing, in which

Fig. 1 shows a view of the nasal douche of the invention in cross-section, in the closed position;

Fig. 2 shows a view in accordance with Fig. 1, in the open position;

Fig. 3 shows a view in accordance with Figs. 1 and 2, in the ventilation position;

Fig. 4 shows an expanded, perspective view of details of the douche according to the invention;

Fig. 5 shows a perspective view of the valve body with the tube attached;

Fig. 6 shows a perspective view of the valve body and tube from a different angle;

Fig. 7 shows an enlarged perspective view of the region of the nasal douche which receives the valve body; and

Fig. 8 shows the region according to Fig. 7 from a different direction, in a partially cut-away view.

Referring first to Figs. 1 to 4, which show the structure of the nasal douche of the invention and how it works, the nasal douche is shown in the upright or vertical position in which it is used. A substantially cylindrical container 1 is sealed in an air-tight and fluid-tight manner by means of a removable lid 2, which has peripheral sealing lips 4, the lid 2 having a metering aperture 6 which can be temporarily blocked or unblocked with one finger. It can be provided for the lid 2 to co-operate with a sealing and retaining bead of the container by means of a peripheral clamping groove, so that it does not become detached from the container and still forms a tight seal even when internal pressure builds up in the container (metering under pressure, see below). Recessed grips 8 (Fig. 4) formed in the outer side walls 16 of the container facilitate holding the douche and simultaneously closing or opening the metering aperture 6.

Internally, the container terminates approximately in its lower third in a bottom wall 10, which forms an indentation 12 with a dispensing aperture 14 disposed in the bottom-most

region of the indentation. The side walls 16 of the container are extended downwards beyond the region the bottom wall 10, so that standing surfaces 18 are formed to set down the container or nasal douche in the (vertical) position shown, i.e. the position for use.

A substantially cylindrical valve body 20 with a tube 22 projecting from it is mounted adjacent to the dispensing aperture 14 such as to be capable of swivelling, so that the different swivel positions shown in Figs. 1 to 3 can be adopted.

Fig. 1 shows the closed position of the valve body, in which the dispensing aperture 14 of the container is blocked by a cylindrical outer surface 24 of the valve body 20.

Fig. 2 shows the position for use, or open position, wherein a connecting duct 26 disposed substantially radially in the valve body 20 is in communication with the dispensing aperture 14, while a delivery duct 28 running through the valve body and the tube 22 adjoins the connecting duct 26, so that a fluid located inside the container can emerge through the delivery duct 28.

Fig. 3 shows a ventilation position of the valve body 20, in which the latter has been swivelled so far that the tube 22 connected to it is completely located between the extended side walls 16 and thus no longer projects beyond the cylindrical or approximately block-shaped outer contours of the container 1, but is covered by them.

Figs. 5 and 6 show enlarged views of the valve body 20 and of the associated tube 22, from which the basic hollow cylindrical shape of the valve body can be seen. The connecting duct 26 has a rectangular cross-section and corresponds in shape and size approximately to the dispensing aperture 14 (Figs. 7 and 8) or to the locating face 25 formed around said dispensing aperture 14, which co-operates with the sealing surface 24.

In the lower portion of the container, substantially planar bearing tags 32 are formed on the bottom wall 10 and the side walls 16, which, in the lateral or axial direction (relative to the swivelling axis of the valve body), have planar limiting walls 34 and C-shaped bearing lands

36, extending in the circumferential direction over an angle of more than 180° at the circumference. This design makes it possible for the valve body 20 to lock in against the elastically slightly deformable bearing tags 32 or the bearing lands 36 and to be removed in the opposite direction, so that the valve body can be inserted and removed without breakage.

Alternatively the lateral cylindrical end portions of the valve body 20, which serve as supports, and the bearing lands 36 (or the valve body as a whole) could be designed asymmetrically, e.g. being of different diameters left and right, in order to ensure that the valve body can only be inserted in the correct alignment (and not twisted round by 180°).

As Figs. 5 to 7 also show, the hollow cylindrical end portions or bearing elements 21 of the valve body 20 are equipped with detent lugs 38 which, in the closed position (Fig. 1) and ventilation position (Fig. 3), co-operate with corresponding detent grooves 40 in the limiting walls 34 of the bearing tags 32, so that the valve body 20 is held fixed in those positions and any accidental swivelling into the open position is prevented. Alternatively the detent lugs 38 and detent grooves 40 can also be left out or replaced by detent means of some other design.

As Figs. 3 and 6 further show, the valve body 20 is equipped with a sloping, tangential shallower portion or recess 42 for emptying residue, which, in the ventilation position (Fig. 3) is opposite the dispensing aperture 14. This ensures that the container 1 in the ventilation position is open at both ends, namely at the metering aperture 6 on the one hand, and the dispensing aperture 14 on the other, and is in communication with the ambient air, which makes ventilation possible and ensures that any residue can be emptied.

For use, the nasal douche is placed in the closed position (Fig. 1), the lid 2 is removed, a desired rinsing fluid is poured in and the lid replaced. The user takes the device in one hand in the vertical alignment shown in the figures of the drawing, and blocks the metering aperture 6, e.g. with his index finger. Following that, the valve body is placed (partially or completely) in the open position (Fig. 2), and the device is ready for use as soon as it has been placed against the nose, the rinsing fluid being metered by (partially) opening the metering aperture 6, so that the rinsing fluid emerges from the tube 22 solely under the force of gravity (hydro-

2002339370 22 Jun 2007

static pressure). If desired, the pressure can be increased by closing the metering aperture 6 and pressing the container 1 (pressure on the side walls 16).

After use, the valve body is placed in the ventilation position (Fig. 3), as a result of which the dispensing aperture 14 is open, owing to the recess 42 for emptying residue, and any remaining rinsing fluid left in the container 1 can escape freely. In the ventilation position, all the surfaces and ducts of the device which come into contact with rinsing fluid are in communication with the ambient air, namely the container 1, the dispensing aperture 14, the delivery duct 28 and the connecting duct 26.

In order to clean the device thoroughly, the valve body 20, as has already been mentioned, can be removed from its mount and replaced without damage. It is important in this connection that the sealing function (valve body vis-à-vis dispensing aperture) is kept separate from the bearing function (valve body vis-à-vis container) by design means, so that even after the valve body has been removed and replaced repeatedly, the sealing function is not impaired.

A further benefit is that the device can be set down on the standing surfaces 18 at the lower end of the side walls 16 in all positions of the valve body 20 (Figs. 1 to 3), and especially in the closed and ventilation positions, so that handling is improved. The possibility of placing the valve body in the ventilation position offers the advantage that the tube 22 is protected against contamination and damage, the recess 42 for emptying residue serving at the same time to empty the device and to provide ventilation.

List of reference numerals

1	Container
2	Lid
4	Sealing lip
6	Metering aperture
8	Recessed grip
10	Bottom wall
23	Indentation
14	Dispensing aperture
16	Side wall
18	Standing surface
20	Valve body
21	Bearing element
22	Tube
24	Outer surface (sealing surface)
25	Locating face
26	Connecting duct
28	Delivery duct
32	Bearing tag
34	Limiting wall
36	Bearing land
38	Detent lug
40	Detent groove
42	Recess for emptying residue

2002339370 22 Jun 2007

THE CLAIMS DEFINING THE INVENTION ARE AS FOLLOWS:

1. A nasal douche with a container for rinsing fluid, which has a dispensing aperture, with a valve body kept movable in the region of the dispensing aperture with a tube attached to said valve body, such that different swivel positions of the valve body in co-operation with the dispensing aperture determine an open position, in which the tube is in communication with the container, and a closed position, in which the container is sealed, characterised by the fact the that valve body can be swivelled into a ventilation position which is different from the open and closed positions, in which the container is ventilated and residue can be emptied.
2. The douche as claimed in Claim 1, characterised by the fact that the container has outer contours overlapping or covering the valve body and tube in the ventilation position, with standing surfaces formed thereon, on which the douche can be set down.
3. The douche as claimed in either of Claims 1 or 2, characterised by the fact that the valve body has a recess for emptying residue, which, in the ventilation position, communicates with the dispensing aperture.
4. The douche as claimed in any of Claims 1 to 3, characterised by the fact that the valve body has a curved sealing surface, which co-operates, in the open and closed positions, with the dispensing aperture, and a connecting duct connected to the tube and leading into the sealing surface communicates, in the open position, with the dispensing aperture.
5. The douche as claimed in Claim 4, characterised by the fact that the container has, on the outside and in the region of the dispensing aperture, a locating face with a curvature corresponding to the sealing surface.
6. The douche as claimed in any of the preceding claims, characterised by the fact that there are, associated with the valve body, detent members which co-operate in at least one position, especially the closed and/or ventilation position, with corresponding detent members of the container and secure the valve body against unintentional swivelling.

2002339370 22 Jun 2007

7. The douche as claimed in any of the preceding claims, characterised by the fact that the valve body can be moved from the closed to the open position by swivelling by about 30° up to about 60°, especially about 45°.
- 5 8. The douche as claimed in any of the preceding claims, characterised by the fact that the valve body is cylindrical in shape and is equipped with bearing elements in its end portions.
9. The douche as claimed in any of the preceding claims, characterised by the fact that the valve body has cylindrical bearing elements which rest in corresponding bearing recesses in the container.
- 0 10. The douche as claimed in Claim 9, characterised by the fact that the bearing elements and bearing recesses are designed to be asymmetrical.
11. The douche as claimed in any of Claims 8 to 10, characterised by the fact that the recess for emptying residue is designed as a bevelled portion of the cylindrical valve body.
- 5 12. The douche as claimed in any of the preceding claims, characterised by the fact that the valve body can be removed from the container and replaced without damage.
13. The douche as claimed in any of the preceding claims, characterised by the fact that the valve body is mounted in lateral bearing tags on the container, which have C-shaped bearing lands extending over an angle of more than 180° at the circumference.
- 20 14. The douche as claimed in Claim 13, characterised by the fact that the bearing tags are formed on side walls of the container, between which the valve body and tube can be received in the ventilation position.
15. The douche as claimed in any of the preceding claims, characterised by the fact that the standing surfaces are formed by free end portions of side walls of the container.
- 25 16. The douche as claimed in any of the preceding claims, characterised by the fact that the tube is formed integrally with the valve body or is designed such as to be capable of being slipped onto the valve body.

2002339370 22 Jun 2007

17. The douche as claimed in any of the preceding claims, characterised by the fact that the container is provided with a tight-sealing lid, which has a metering aperture.
18. The douche as claimed in Claim 17, characterised by the fact that the lid is retained on the container in such a way that it provides a tight seal when there is internal pressure.
- 5 19. A nasal douche substantially as described with reference to Figures 1 to 8.

**SIEMENS & CO. HEILWASSER UND QUELLENPRODUCKTE DES
STAATSBADES BAD EMS GMBH & CO. KG**

0 P23971AU00

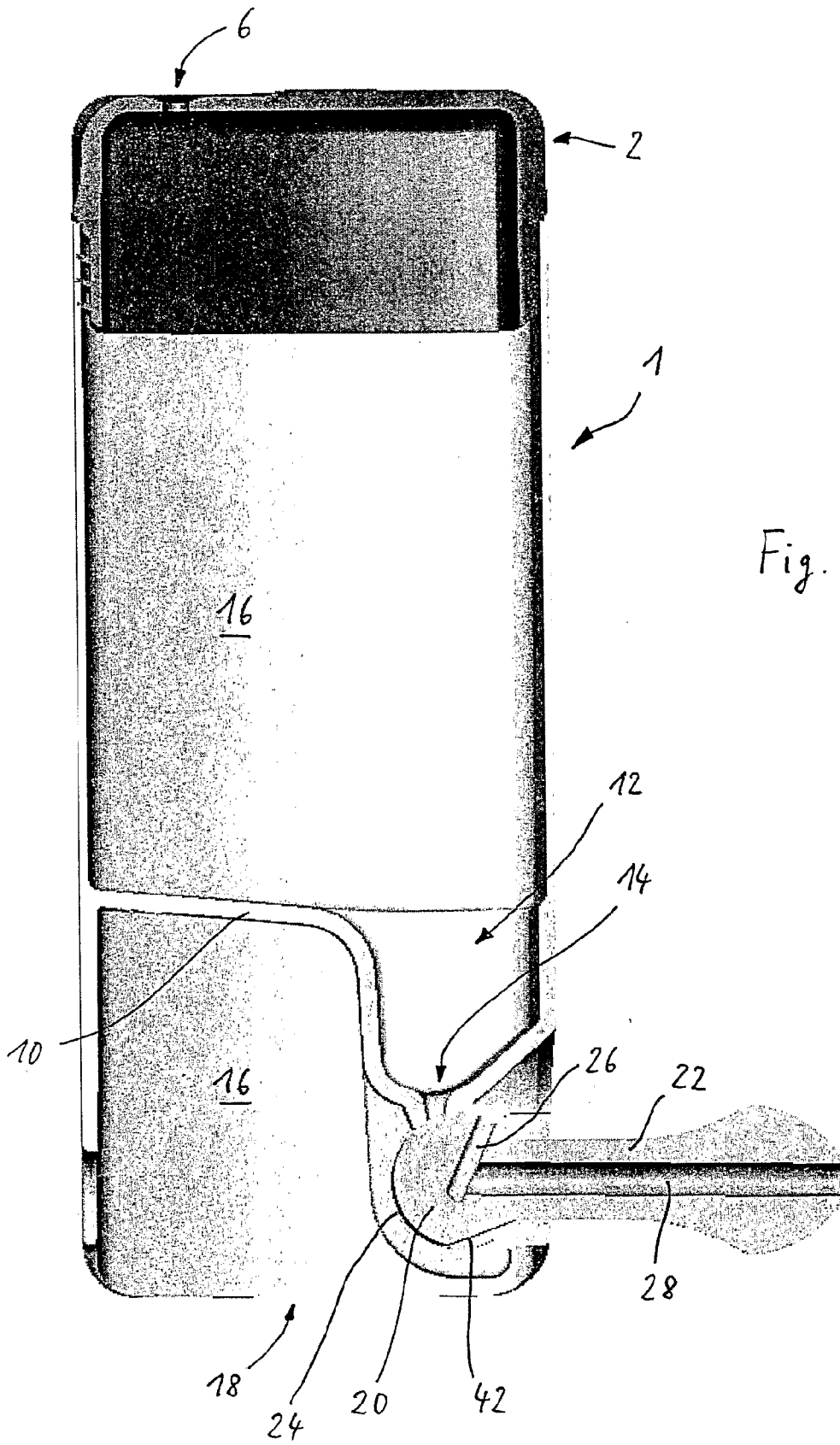

Fig. 1

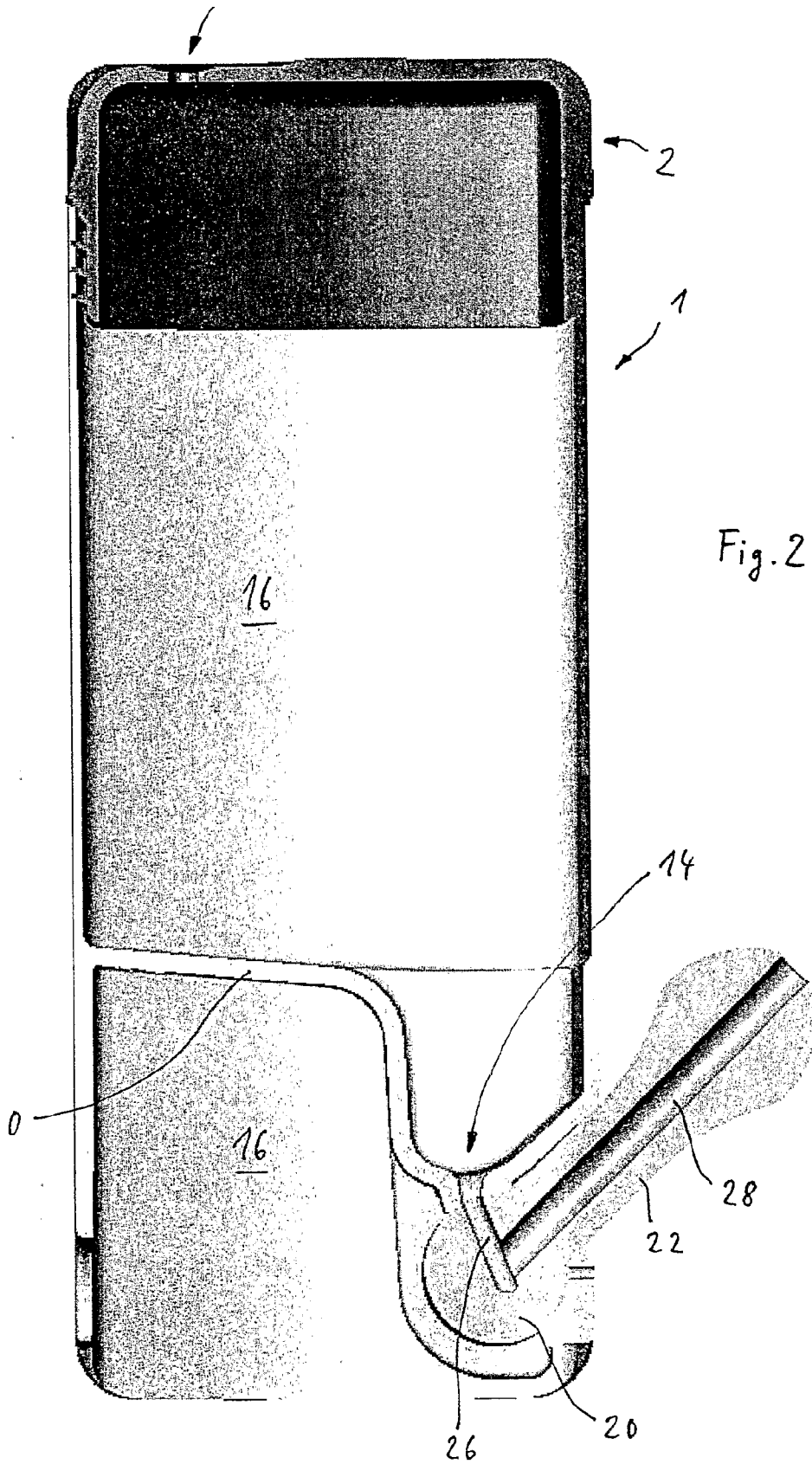

Fig. 2

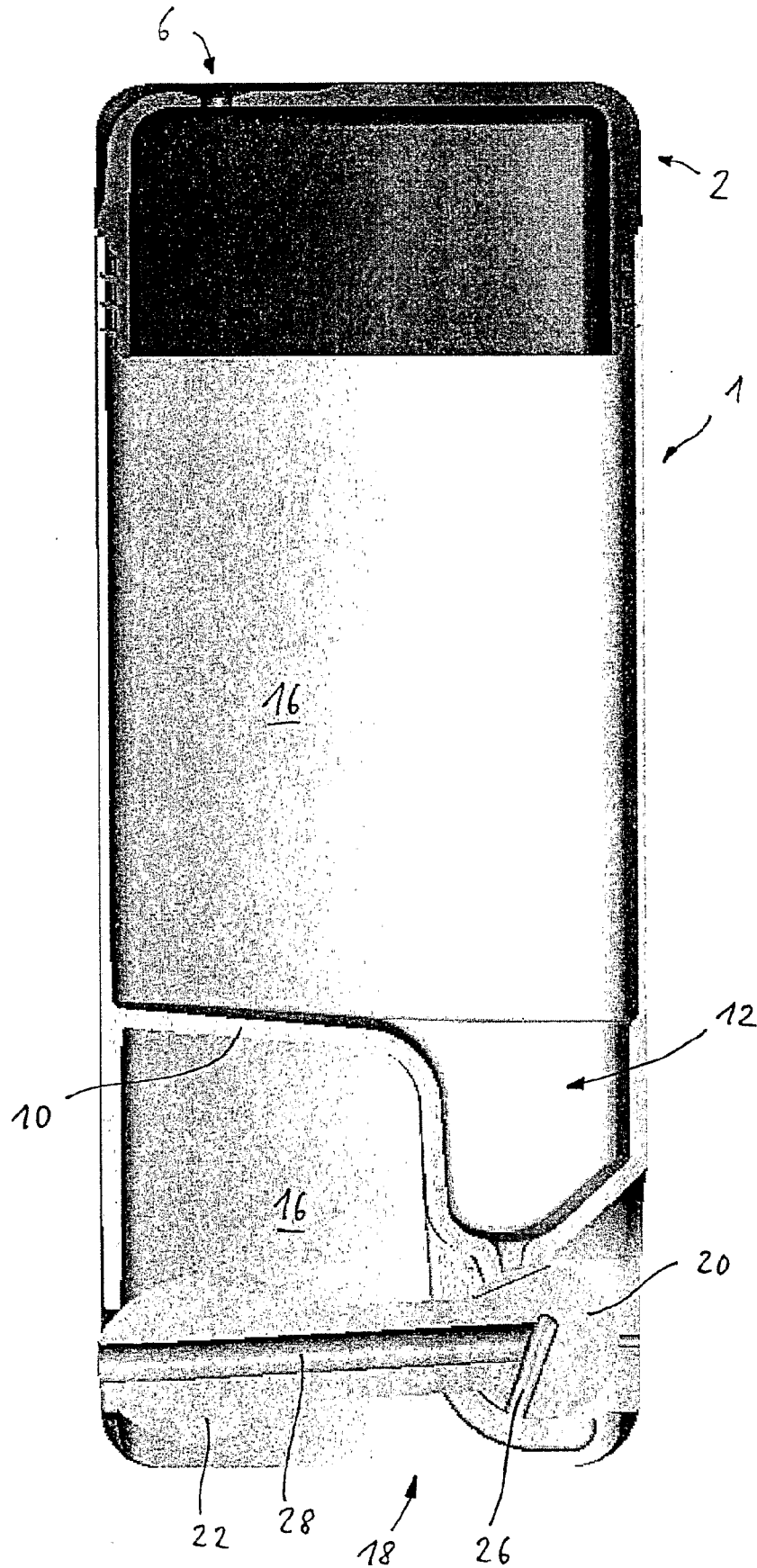

Fig. 3

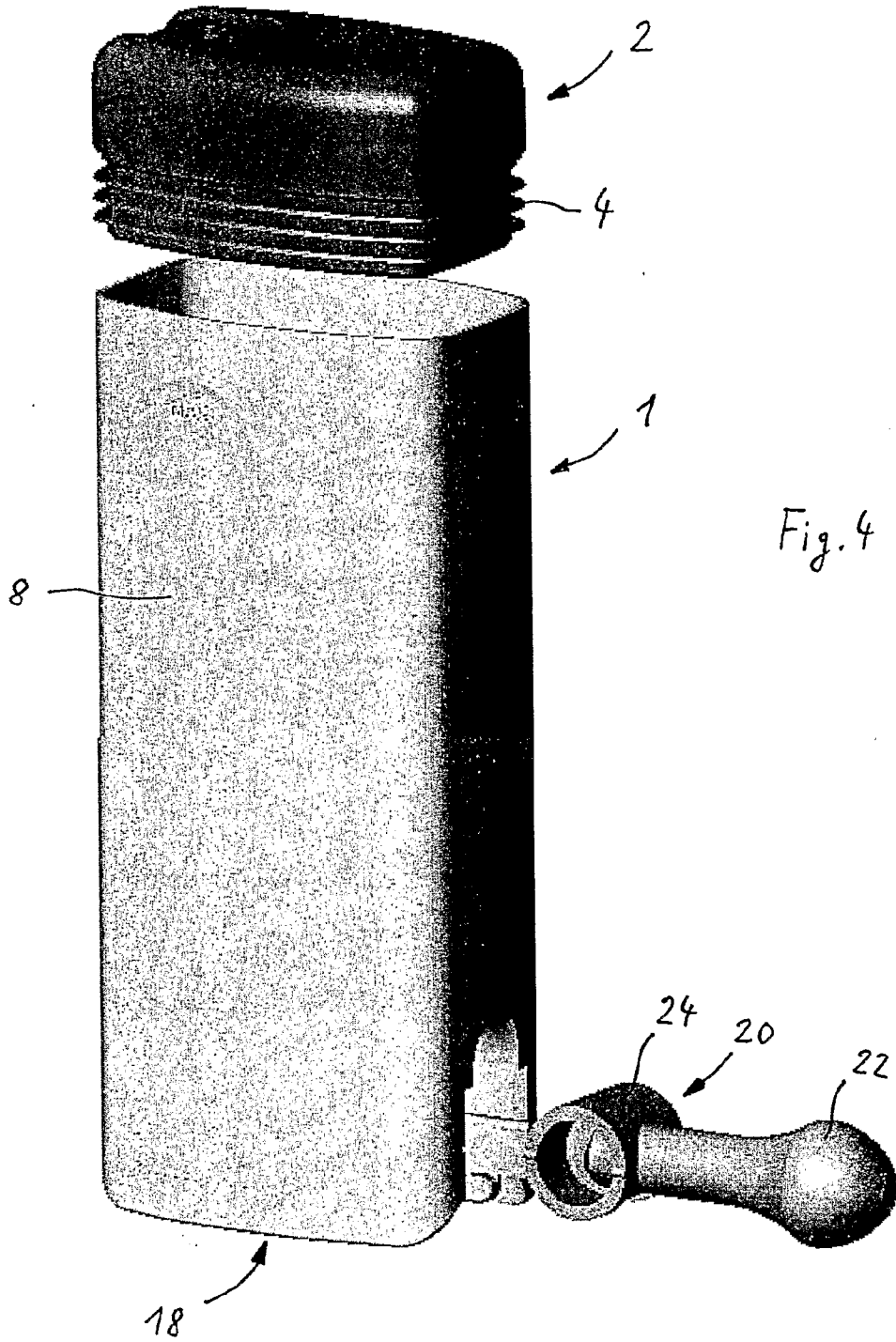

Fig. 4

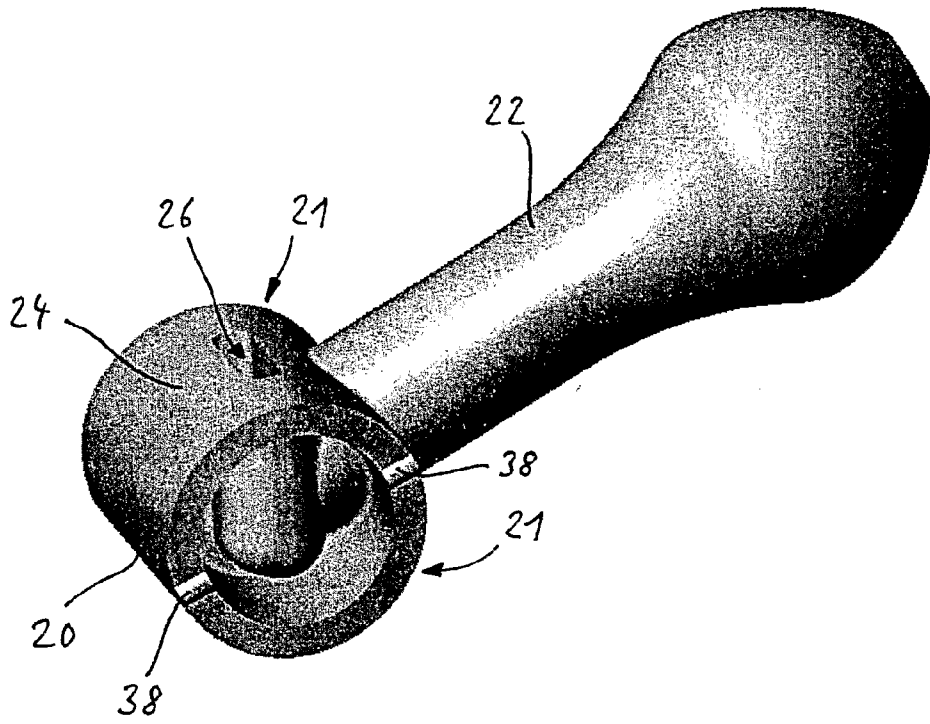

Fig. 5

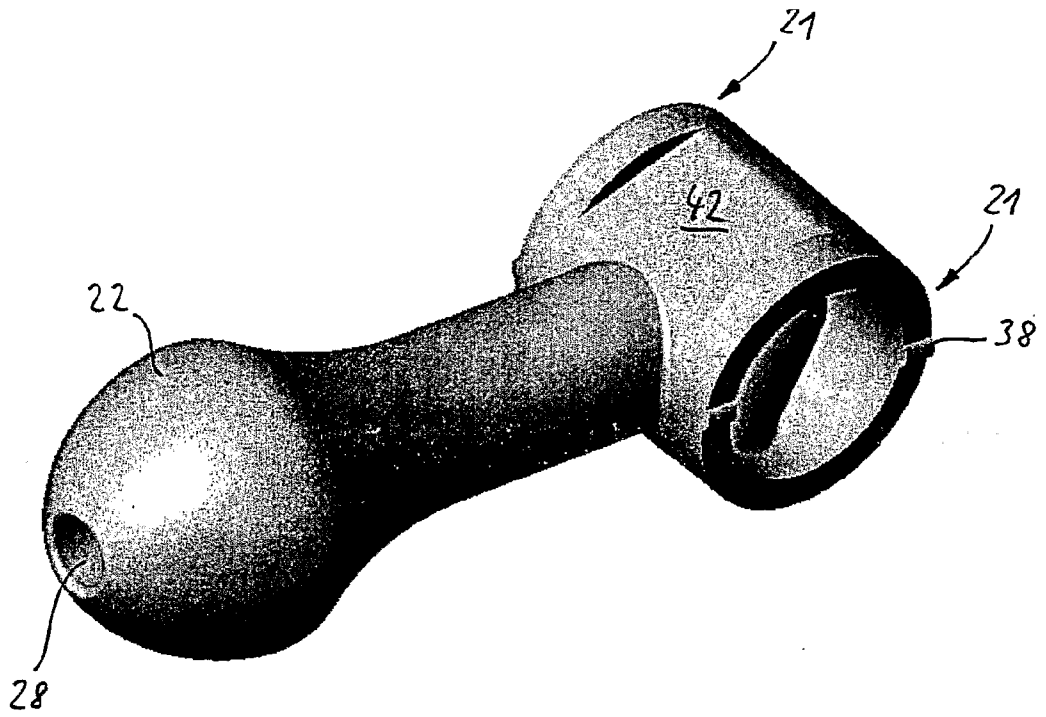

Fig. 6

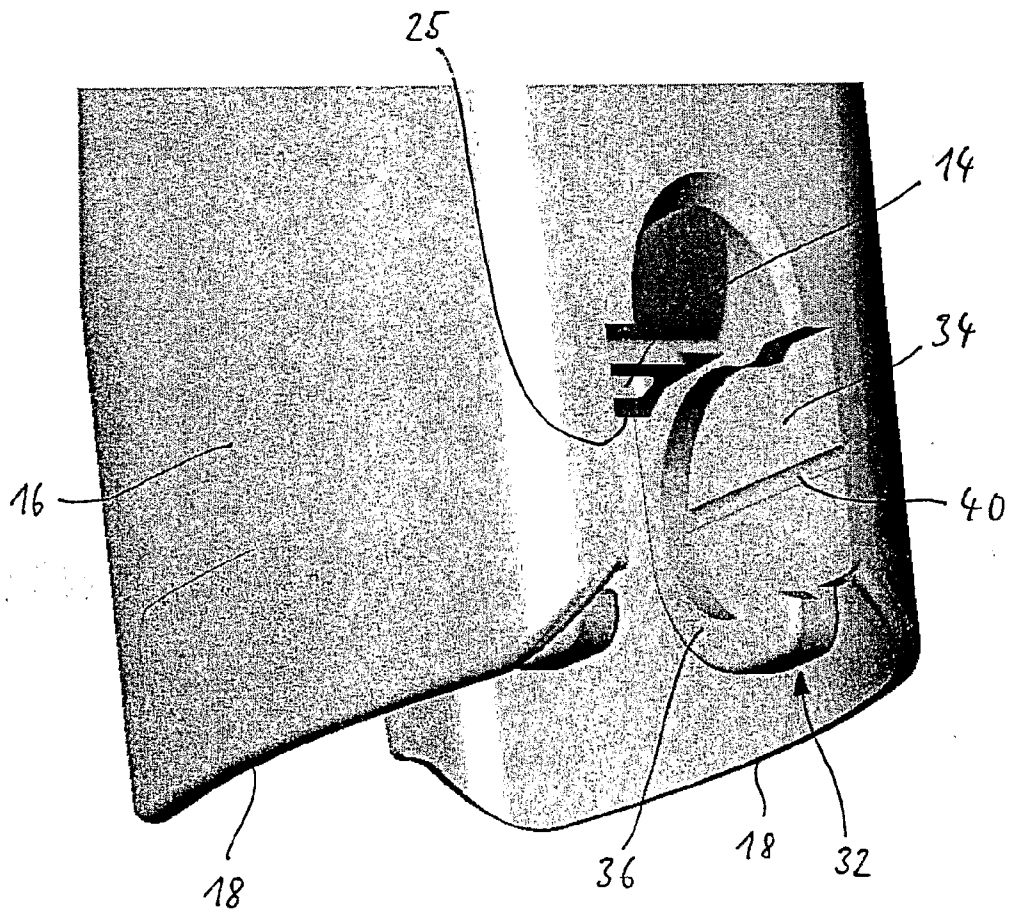

Fig. 7

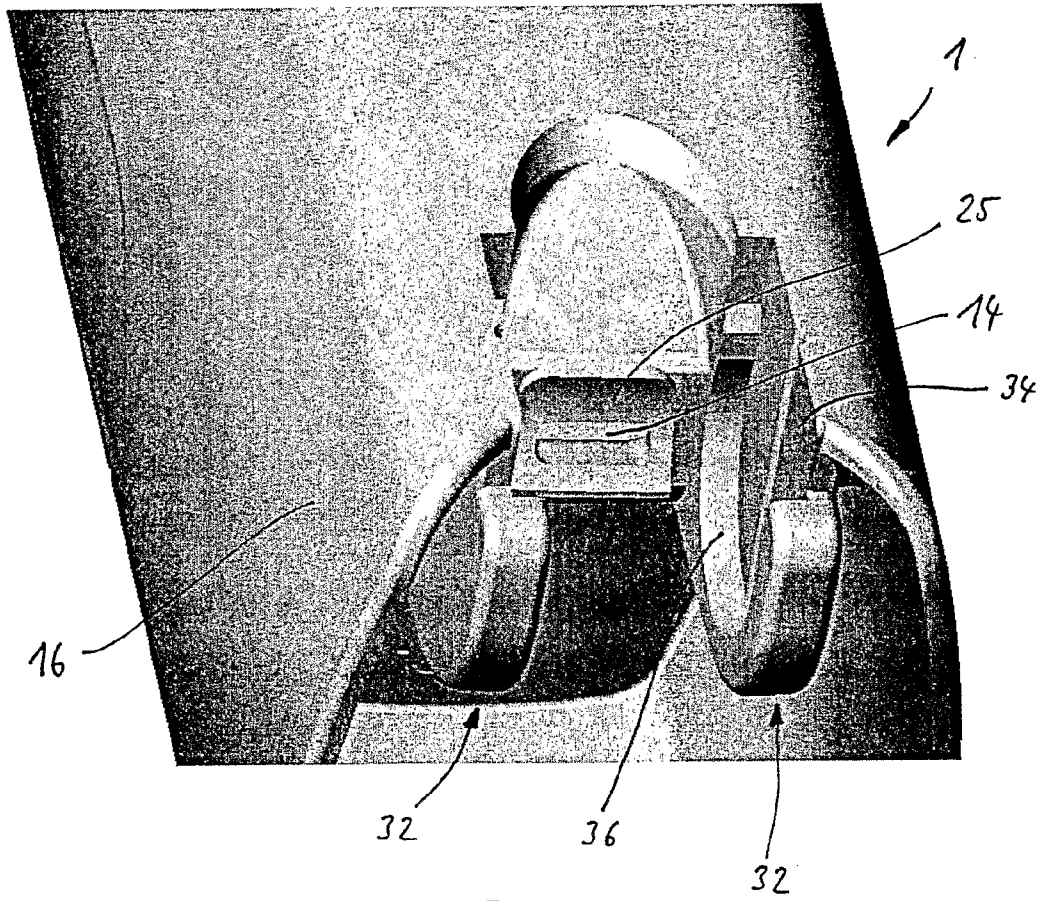

Fig. 8