

(No Model.)

J. H. BOEKEN.
DECORTICATING MACHINE.

No. 524,573.

Patented Aug. 14, 1894.

Fig: 1.

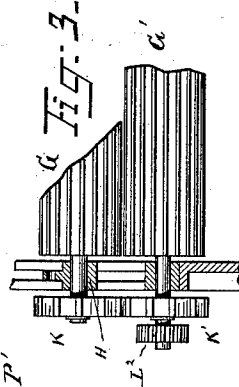
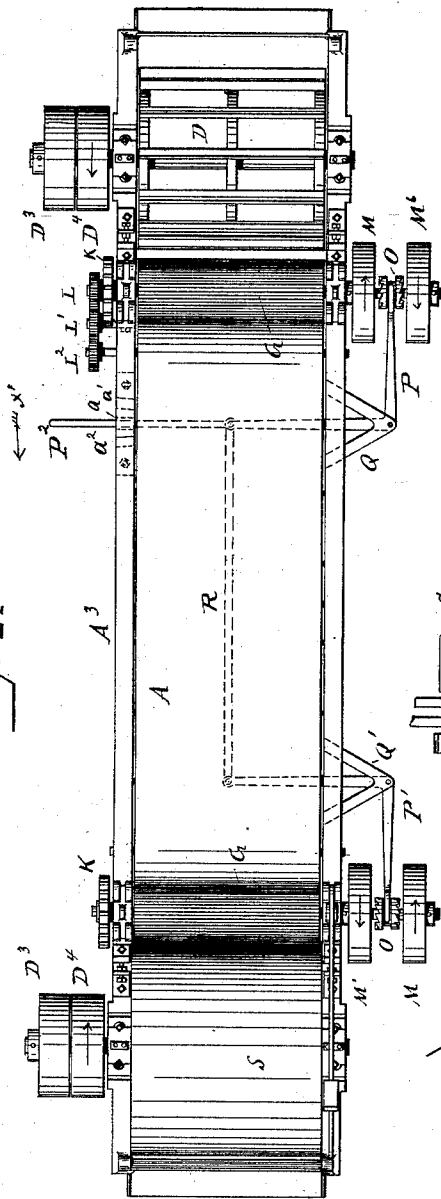

Fig: 2.

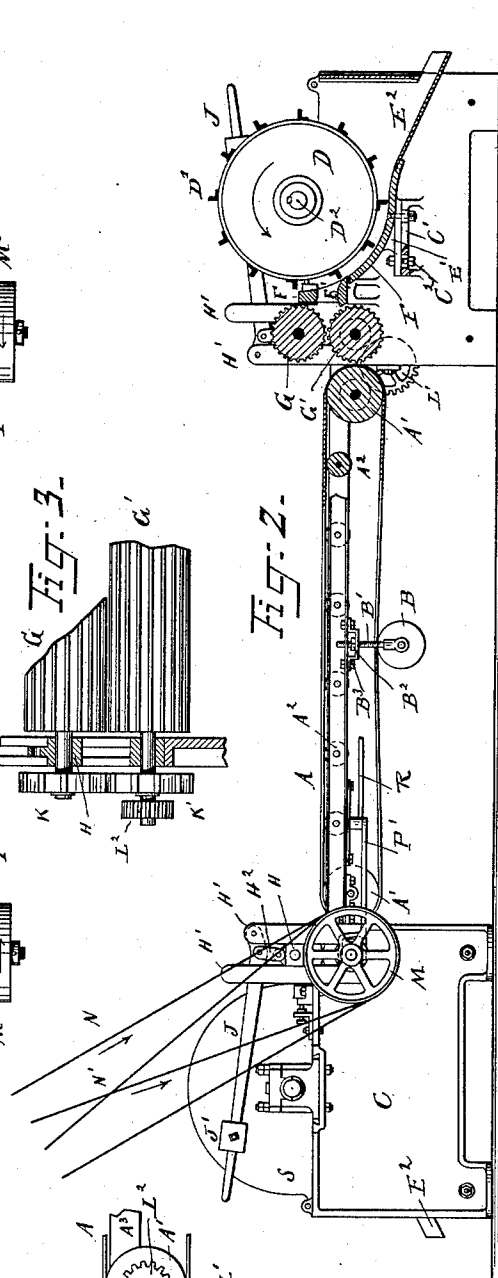
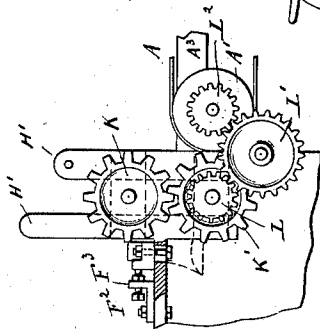

Fig: 4.



WITNESSES:
S. Schi-Palmieri
Otto Reiss

INVENTOR
J. H. Boeken
BY *Gappel Raeymer*
ATTORNEYS.

UNITED STATES PATENT OFFICE.

JOSEPH HUBERT BOEKEN, OF NUEVITAS, CUBA.

DECORTICATING-MACHINE.

SPECIFICATION forming part of Letters Patent No. 524,573, dated August 14, 1894.

Application filed March 19, 1894. Serial No. 504,231. (No model.)

To all whom it may concern:

Be it known that I, JOSEPH HUBERT BOEKEN, a subject of the Queen of Great Britain, and a resident of Nuevitas, Cuba, have invented certain new and useful Improvements in Decorticating-Machines, of which the following is a specification.

This invention relates to improvements in that class of machines that are used for separating the vegetable fiber in the stalks and leaves of the ramie, heniquen, sisal and like plants from the epidermis and pulp in such a manner that the said fibers can be used in the arts for various purposes.

The object of my invention is to provide a new and improved machine of this kind which is simple in construction, thoroughly separates the fiber from the epidermis and pulp, and by means of which a very large quantity of stalks or leaves can be treated in a given time.

The invention consists in the combination with two decorticating mechanisms, of a conveyer located between them and mounted to move toward either mechanism.

The invention further consists in the combination with the decorticating mechanisms and the conveyer, of means for operating the conveyer from one of said decorticating mechanisms and means for reversing the direction of movement of the conveyer and at the same time reversing the direction of rotation of the feed-rollers of the said decorticating mechanisms.

The invention further consists in the construction and combination of parts and details as will be fully described hereinafter and finally pointed out in the claims.

In the accompanying drawings, Figure 1 is a plan view of my improved decorticating machine, parts being omitted. Fig. 2 is a side view of the same, parts being shown in vertical section. Fig. 3 is an enlarged detail side view of the feed rollers and gearings, parts being shown in section. Fig. 4 is an enlarged detail elevation, showing the gearing for driving the feed-roller and the conveyer belt.

Similar letters of reference indicate corresponding parts.

An endless conveyer belt A passes over the rollers A' and A' and the top part of said belt rests on a series of supporting rollers A²

mounted to turn in a frame A³, which also supports the end rollers A'. The bottom part of the belt rests on a tension roller B, supported by screws B' passing through nuts B² on brackets B³ of the frame A³, so that by turning said nuts the tension roller B' can be raised or lowered according to the desired tension for the endless belt. Adjacent to each end roller A' a decorticating mechanism is arranged in a suitable frame C. In said frame C a beating drum or scutcher D is mounted to rotate and is provided on its periphery with a series of scutching blades D'. On the shaft D² of said drum a loose pulley D³ and a fixed pulley D⁴ are mounted for a driving-belt, which belt rotates said drum D in the direction shown by the arrow in Fig. 2. Below and slightly to one side of said drum, a curved metal plate E is arranged, the curvature of which is the same as that of the drum, said plate having a foot E' resting on a bracket C' of the frame C. Bolts C² pass through said bracket C' and through the foot E' of the curved plate, the bracket having slots, so as to permit of adjusting the said plate in horizontal direction toward or from the periphery of the drum, according to the thickness of the fiber of the leaves or stalks to be treated.

An inclined chute E² serves for carrying off the pulp and pieces of the epidermis from the lower end of the plate E. At the upper end of the curved plate E, a throat-piece F is arranged, which has an opening F' through which the leaves or stalks can pass, the bottom edge of said opening being curved. That side of the throat piece facing the drum D has the same curvature as the plate E and forms a continuation of the same. The throat piece is mounted to slide horizontally toward or from the drum and can be shifted by means of screws F², Fig. 4, passing through angle-pieces F³ on the frame C of the machine and engaging the ends of the throat-piece.

At that side of the throat-piece opposite the one facing the drum, two feed-wheels G and G' are mounted parallel and one above the other, said feed-wheels being provided with longitudinal flutings, grooves or ridges in their peripheral surface. The lower roller G' is mounted in fixed bearings and the upper one G in movable bearings H arranged to slide

vertically between two standards H', said movable bearing H being connected by a link H² with a lever J pivoted to one of the standards and carrying an adjustable weight J' so as to admit of adjusting the pressure exerted on said upper roller, according to the nature of the plant or leaf under treatment.

The shafts of the rollers G and G' carry the cog-wheels K and K', the teeth of which are of such length as to remain in engagement at all times, whether the feed-rollers are close together or separated a greater or less distance. The shaft of the lower feed-roller G' on one of the decorticating mechanisms, in this case the one at the right, carries a cog-wheel L engaging an idle cog-wheel L' on the frame of the machine, which cog-wheel L' in turn engages the cog-wheel L² fixed on the shaft of one of the end rollers A' of the endless conveyer belt A, so that said endless belt is driven from the shaft of said feed-roller.

The shaft of the lower feed-roller G' of each decorticating mechanism carries two loose belt pulleys M and M', which are rotated by the belts N and N' in opposite directions. Between said two pulleys M and M' a sliding clutch O is mounted on the shaft of the lower feed-roller G' which clutch rotates with the shaft and can slide longitudinally on the same, so as to be engaged with either belt pulley M or M'. The clutches O are grooved circumferentially and into said grooves the forked ends of two angle-levers P and P' pass, which angle levers are pivoted to laterally-projecting brackets Q and Q' of the frame A³, supporting the endless belt. One shank of the angle-lever P' extends entirely across the frame A³ its end P² serving as a handle for manipulating said levers. The levers P and P' are connected by a connecting-rod R in the manner shown. The drums D are each covered by a removable semi-circular hood S which in Figs. 1 and 2 is shown upon the frame C at the left-hand ends of said figures.

The operation is as follows: The drums D are rotated at a speed of about six hundred revolutions per minute and the pulleys on the shafts of the feed-rollers G' are rotated at such speed that the endless belt A travels at the speed about equal to two thirds of the peripheral speed of the said drums D. When the handle end P² of the angle-lever P is in the central notch a in the top of the frame A³ as shown in Fig. 1, the clutches O and O' are disengaged from the pulleys M and M' and the endless belt A is at rest. A number of leaves or stalks are placed longitudinally side by side on the endless belt A, so that their larger or butt ends are adjacent to the feed-rollers G and G' of the right-hand decorticating mechanism. The handle P² is then moved in the direction of the arrow x', Fig. 1 and passed into the notch a² whereby the clutches O and O' are engaged with the pulleys M and thereby the feed-rollers G and G' of the right-hand mechanism are rotated, so as to draw the leaves in between them, and

at the same time the top of the conveyer belt A is moved in the inverse direction of the arrow x'. The epidermis of the leaves is crushed and broken by passing the feed-rollers, and as the leaves pass down the curved plate E, the epidermis is torn and scraped from the same and the pulp removed from between the fibers by the blades D' of the rapidly rotating scutcher drum D. When the points of the leaves or stalks are within a short distance from the feed-rollers G and G' of the right hand mechanism, the lever P² is moved in the inverse direction of the arrow x', and passed into the notch a', whereby the clutches O and O' are disengaged from the belt pulleys M and engaged with the pulleys M', and thereby the direction of rotation of the feed-rollers G G' is reversed and the top of the conveyer belt is now moved in the direction of the arrow x'. By the reverse motion of the feed-rollers G, G', the stalks or leaves are now drawn up through the opening F' of the throat-piece on the right-hand decorticating mechanism, contrary to the direction of rotation of the scutcher drum D and conveyed back upon the conveyer belt, and are carried by said conveyer belt to the left and in between the feed-rollers of the left-hand decorticating mechanism, passed through the mouth piece of the left-hand decorticating mechanism and are acted upon by the scutcher drum D of said left-hand mechanism. After the leaves have been drawn into said left-hand mechanism almost their entire length, the machine is again reversed and the leaves or stalks are again conveyed by the feed-rollers of the left-hand mechanism, upon the endless conveyer belt A, and by the same in the inverse direction of the arrow x'. Attendants then remove the fiber, which is all that remains of the stalk or leaves from the endless belt and the fiber is then dried and treated in the usual manner by suitable appliances. Fresh leaves or stalks are placed on the belt and passed through the two decorticating mechanisms in the manner described.

In my improved machine the stalks or leaves are decorticated throughout the greater part of their length by one decorticating mechanism, are then conveyed to the other decorticating mechanism for the purpose of having that part decorticated that was not acted upon by the first decorticating mechanism. Furthermore part of the stalk or leaf is first acted upon by scutchers that move in the same direction with the stalk or leaf and then are acted upon by the same scutchers, while traversing in the inverse direction on the return motion. By this action of the scutchers on the stalks or leaves all the particles of the epidermis and pulp between the fibers are removed without crushing or breaking the fibers or endangering the latter, and the fibers are at all times held in line and are never doubled up or twisted. The result is that the fibers obtained on my machine can be hacked and

spun very easily and do not require much combing.

Having thus described my invention, I claim as new and desire to secure by Letters Patent—

1. In a decorticating machine, the combination with an endless conveyer belt, supporting rollers for said belt, of a tension device for said belt, a pair of feed rollers at each end of the conveyer belt, brackets attached to the side of the machine, reversing mechanism for the feed rollers consisting of clutches, angle levers pivoted to said brackets for operating said clutches, a horizontal lever connecting said angle levers, and a handle working in notches on the machine for simultaneously operating said clutches, transmitting gears between one pair of feed rollers and the conveyer belt for producing the simultaneous motion of the feed rollers and conveyer belt in either direction, a throat piece arranged adjacent to each pair of feed rollers, curved plates below the throat pieces, and rotary scutchers located in close proximity to the throat pieces and above the curved plates.

2. In a decorticating machine, the combination of an endless conveyer belt, a pair of feed rollers at one end thereof, vertical standards also disposed at one end of said belt, a movable bearing in said standards in which one of said feed rollers is journaled, a lever piv-

oted to one of the standards and provided with a weight, a link connecting said lever with said movable bearing for lowering and raising the feed roller journaled thereon, a rotary scutcher, a curved plate mounted below the same for supporting the leaves on which the scutcher acts, a throat piece at the upper end of said plate and having an aperture through which the leaves can pass to the scutcher, and means for adjusting the throat piece in relation to the curved plate and scutcher.

3. In a decorticating machine, the combination with an endless conveyer belt, of a pair of feed rollers at one end thereof, a rotary scutcher, a curved plate mounted below the same for supporting the leaves on which the scutcher acts and provided with a foot, a support for said foot provided with a slot, means for adjusting the plate horizontally and bodily in the slot of said support, and a throat piece at the upper end of said plate and having an aperture through which the leaves can pass to the scutcher.

In testimony that I claim the foregoing as my invention I have signed my name in presence of two subscribing witnesses.

JOSEPH HUBERT BOEKEN.

Witnesses:

OSCAR F. GUNZ,
K. R. BRENNAN.