



US 20040209744A1

(19) **United States**

(12) **Patent Application Publication**

Tsujimoto

(10) **Pub. No.: US 2004/0209744 A1**

(43) **Pub. Date: Oct. 21, 2004**

(54) **MARTIAL ARTS EQUIPMENT**

Publication Classification

(76) **Inventor: Takeshi Tsujimoto, Osaka (JP)**

(51) **Int. Cl.7** **A63B 71/00; A63B 69/34**

(52) **U.S. Cl.** **482/83**

Correspondence Address:

**KNOBBE MARTENS OLSON & BEAR LLP
2040 MAIN STREET
FOURTEENTH FLOOR
IRVINE, CA 92614 (US)**

(57) **ABSTRACT**

A martial arts equipment that appears slim and light and can be made lightweight is proposed. The martial arts equipment includes an equipment body 1 that is worn by a participant during match or practice of martial arts activities in which one participant inflicts a blow to the other participant's body, and that is filled with an impact-reducing material 3 at places where an impact involved in the blow is delivered. The impact-reducing material 3 includes a high impact absorptivity high density foam material 3A having excellent impact absorbing performance in a layer form.

(21) **Appl. No.: 10/827,016**

(22) **Filed: Apr. 19, 2004**

(30) **Foreign Application Priority Data**

Apr. 21, 2003 (JP) 2003-115673

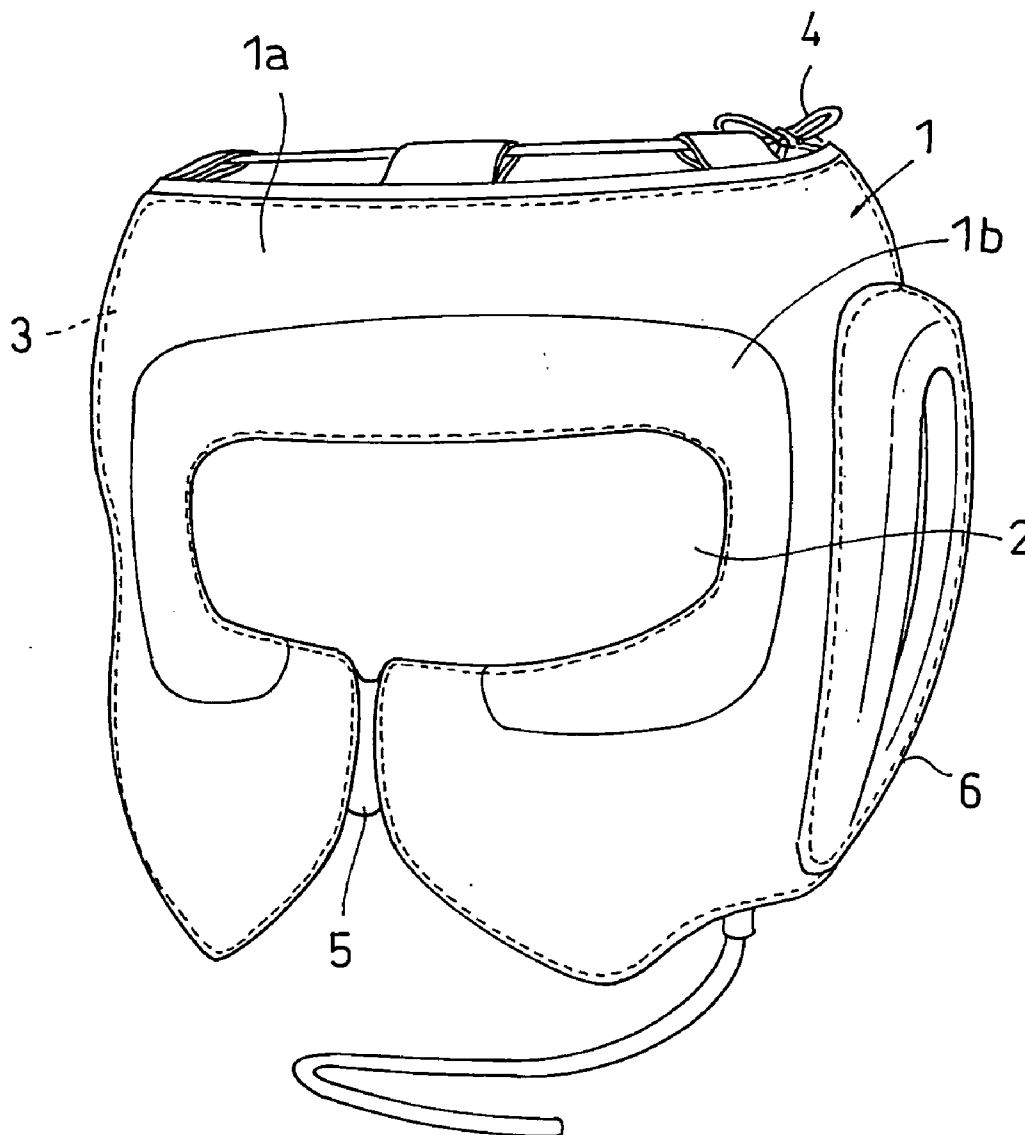

FIG. 1

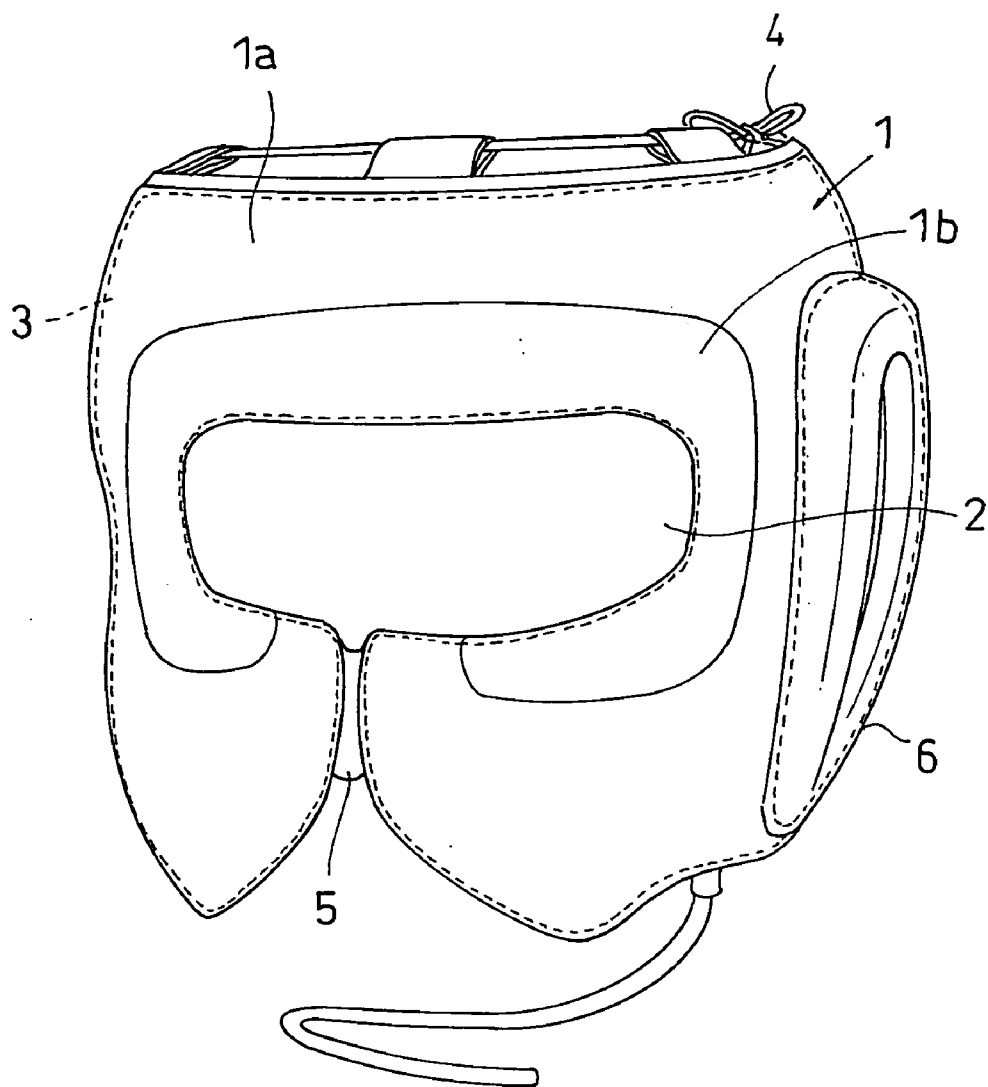

FIG. 2

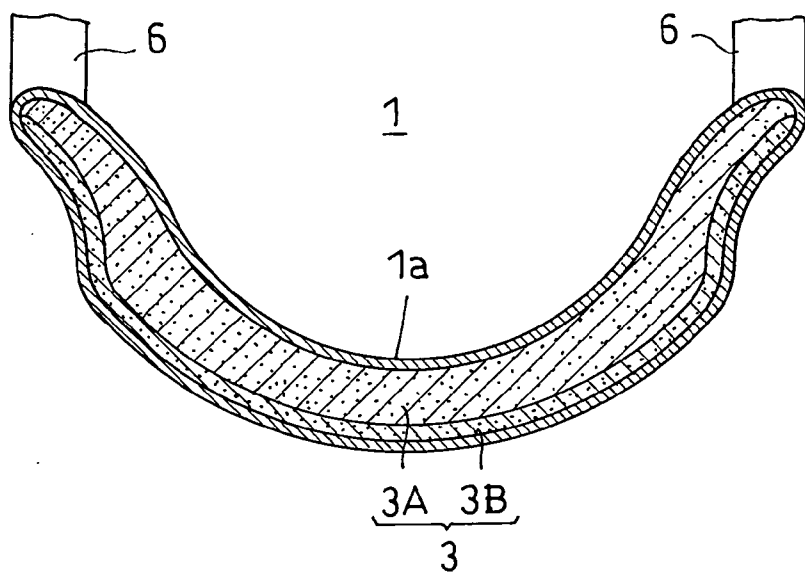

FIG. 3

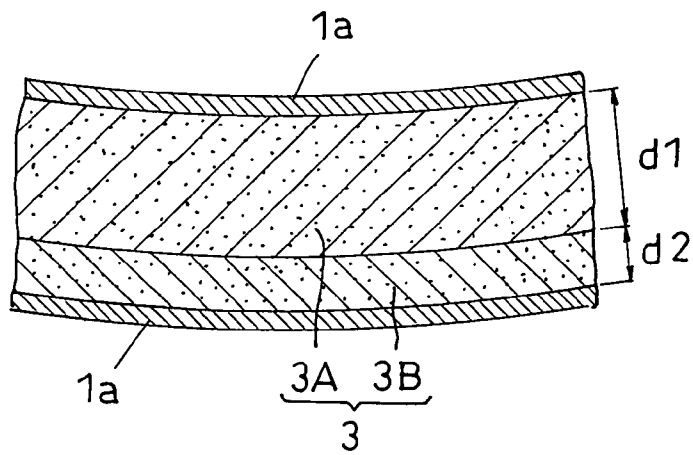

FIG. 4

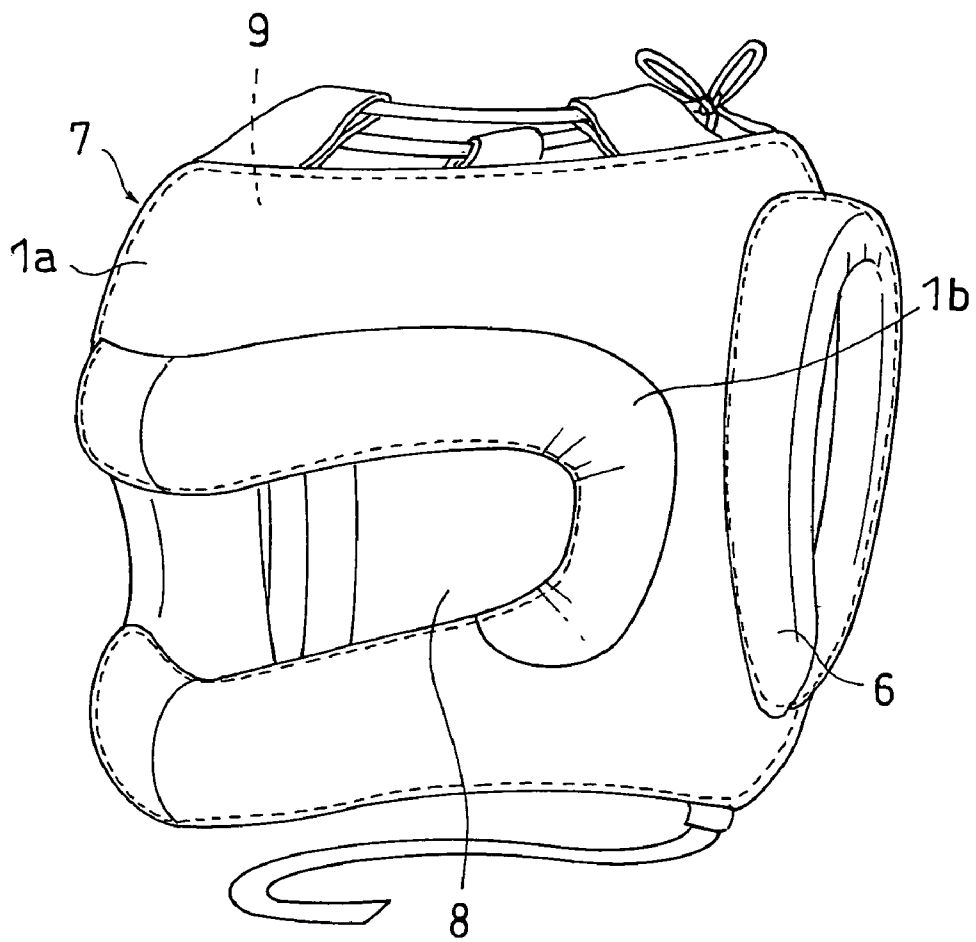

FIG. 5

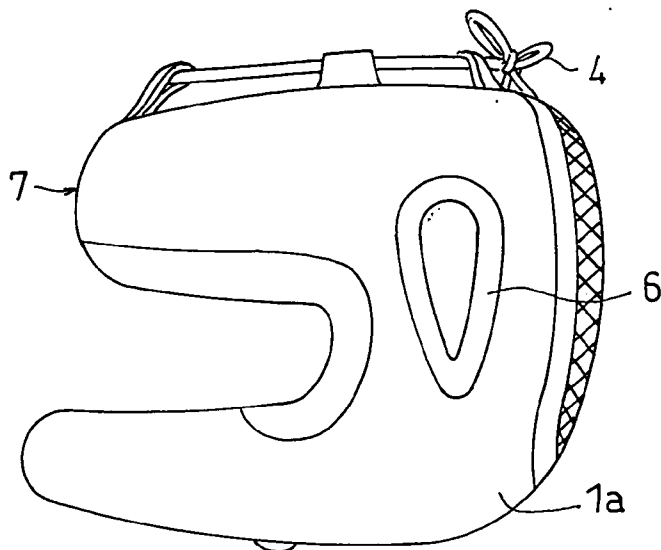

FIG. 6

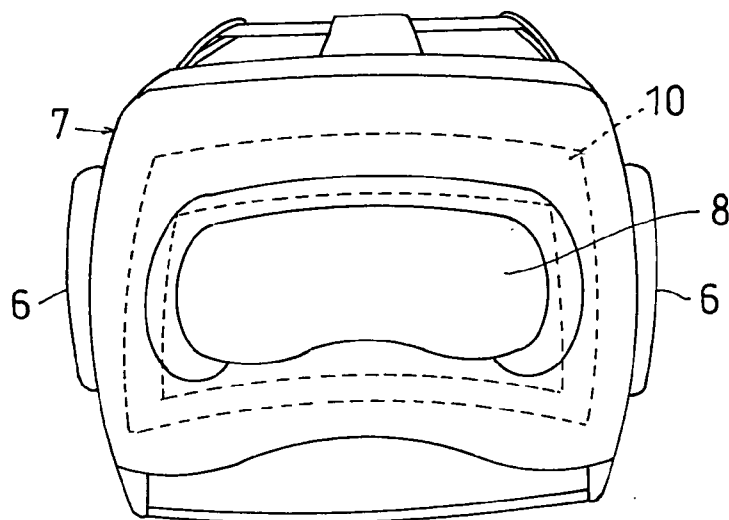

FIG. 7

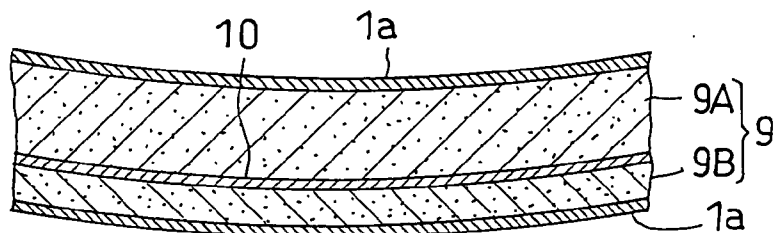

FIG. 8

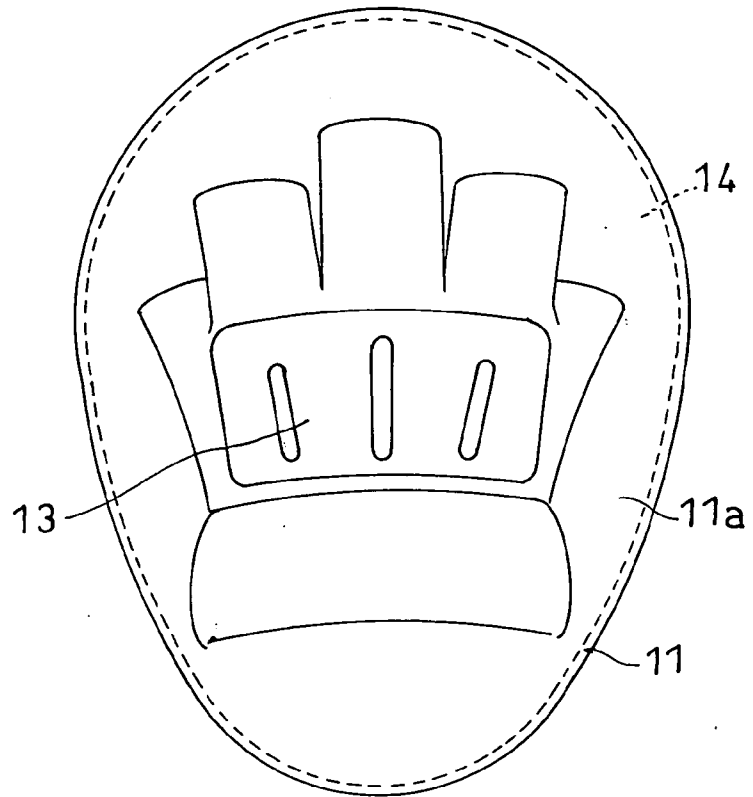

FIG. 9

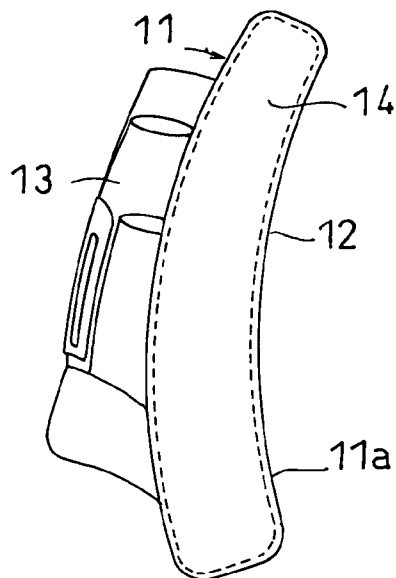

FIG. 10

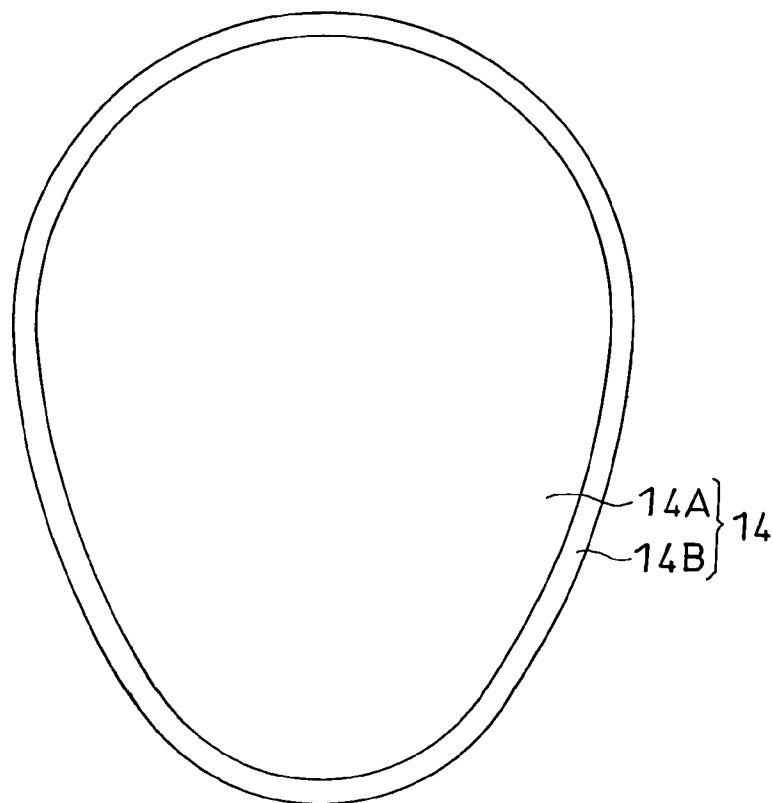

FIG. 11

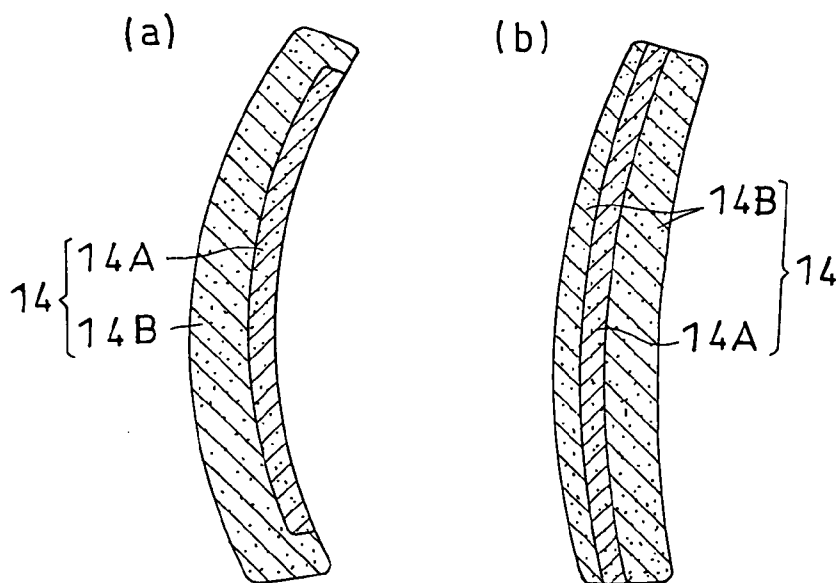

FIG. 12

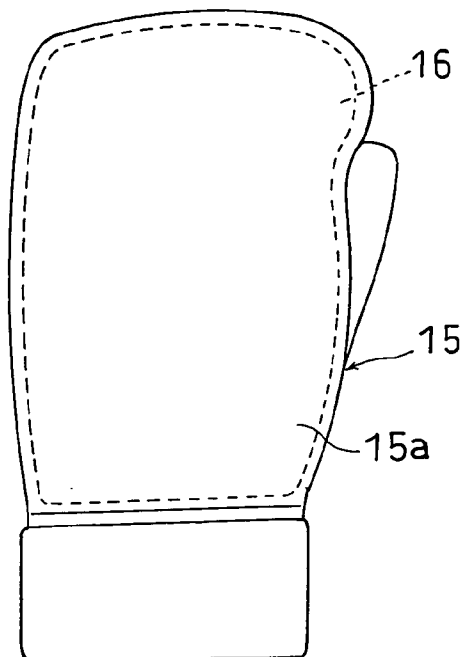

FIG. 13

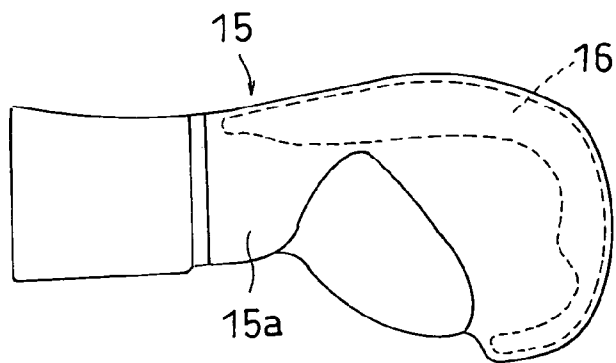

FIG. 14

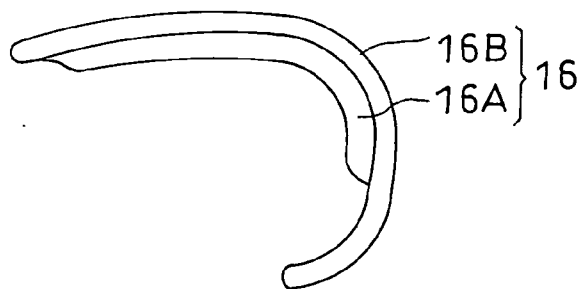

FIG. 15

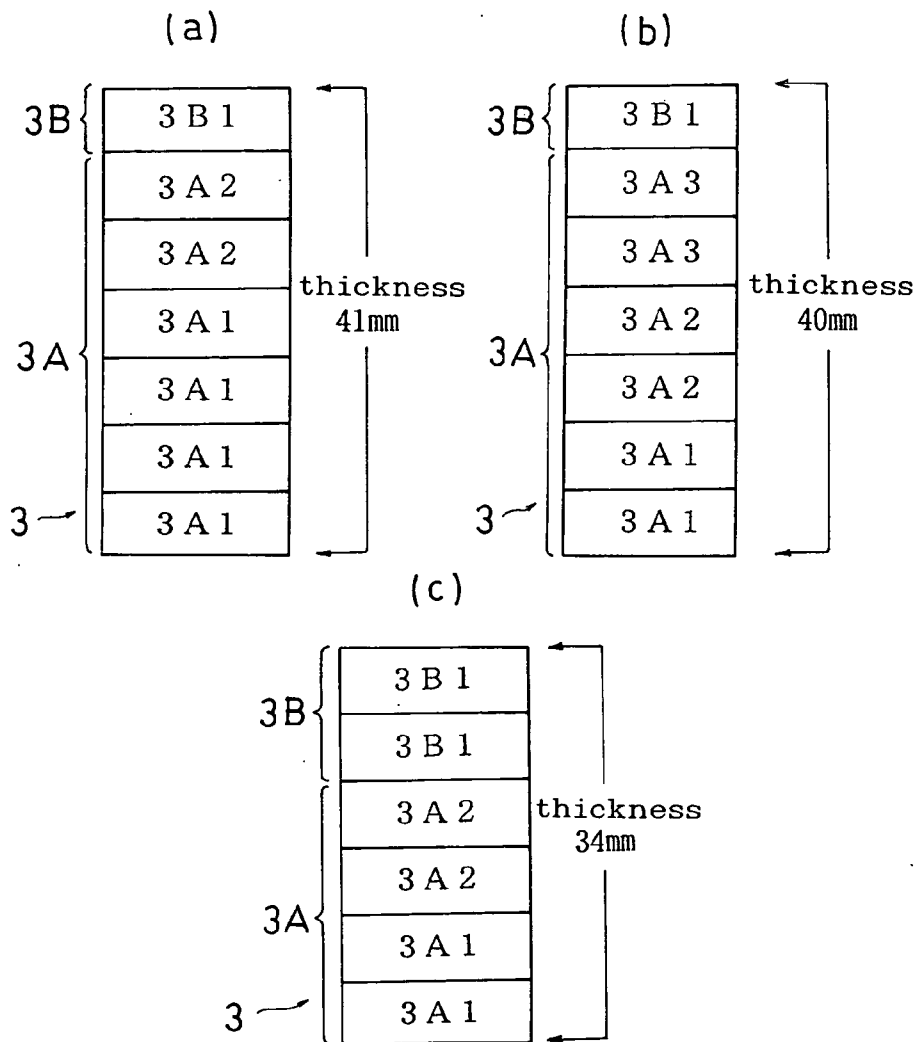
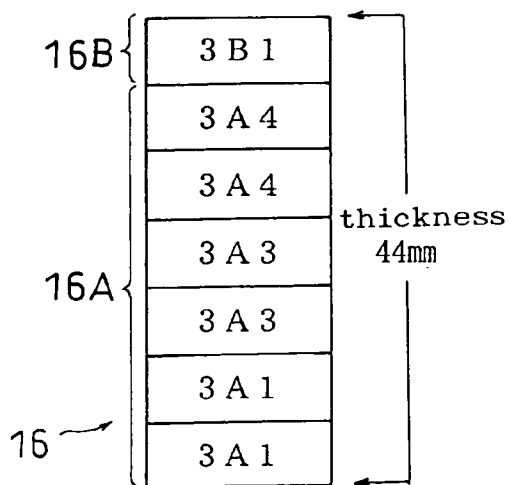

FIG. 16



MARTIAL ARTS EQUIPMENT

BACKGROUND OF THE INVENTION

[0001] 1. Field of the Invention

[0002] The present invention relates to martial arts equipments, and more specifically, to a martial arts equipment that is used in martial arts activities in which one participant inflicts a blow to the other participant's body, that is worn by the participants during match or during practice in the martial arts activities, and that includes an equipment body filled with an impact-reducing material in places where impacts involved in the blow are delivered.

[0003] 2. Description of the Related Art

[0004] Recently, during a match or a practice in karate or boxing, a headgear, serving as martial arts equipment, including a gear body, serving as an equipment body, is worn over the head of the participant to protect the head of the wearer. In the conventional headgear, an opening for exposing an area from the eyes to the mouth of the wearer is formed in the front face of the gear body, and the front face and the side faces of the gear body are filled with an impact-reducing material. By encompassing the face and both the left and right sides of the face of the wearer with a sponge type impact-reducing material, such parts are protected from the impact of the blow. When using such headgear, the gear body is fitted to the head by tying the ends at the back of the head with strings. As long as the headgear is worn, even if the opposing participant inflicts a blow to the head, the impacts of such heavy blow will be absorbed and reduced by the impact-reducing material in the gear body. Thus the damage is minimized and the fist or the wrist of the opposing participant who has inflicted the blow will also not be hurt. A safe match or practice will then be carried out.

[0005] In the conventional headgear, the impact-reducing performance of the conventional impact-reducing material is not very high, and thus for the participants to pursue a safe match or a practice, the thickness of the sponge at the upper front and at both sides of the nose of the gear body needs to be greater than other places to increase the impact-reducing performance (e.g., nonpatent literature 1).

[0006] Nonpatent Literature 1

[0007] The 2001-2002 CATALOG issued from Winning USA Co. is incorporated herein by reference in its entirety.

[0008] However, the conventional headgear has a disadvantage in that such head gear appears thick and heavy, and is far from appearing light. The thickness of the sponge at the upper front part and at both sides of the nose is thicker than other places and thus such places are larger and bulkier, causing the wearers to feel the headgear as thick and heavy. Especially, if the participant is young and not an adult, or if the participant does not have enough physical strength, the weight of the equipment becomes a burden during the activity, and might diminish the enjoyment of such activity.

SUMMARY OF THE INVENTION

[0009] The present invention thus proposes a martial arts equipment, in view of the nature of the prior art, that appears slim and light and that can be made lightweight.

[0010] The above mentioned aim is achieved by the present invention described in the appended claims.

[0011] The present invention proposes a martial arts equipment that is worn by a participant during a match or a practice of a martial arts activity in which one participant inflicts a blow on the other participant's body, and that includes an equipment body filled with an impact-reducing material at places subjected to the impact involved in the blow, the impact-reducing material is layer structured consisting of a high impact absorptivity high density foam material having an excellent impact absorbing performance.

[0012] In this martial arts equipment, when the participant wears the equipment body, the equipment body receives the impact that is sometimes involved in the blow during the match or the practice. However, most of the impact involved in the blow is absorbed and weakened by the impact-reducing material, and thus the match or the practice can be safely carried out.

[0013] In one aspect of the martial arts equipment of the present invention, the impact-reducing material of the equipment body has a configuration in which the high density foam material (high impact absorptivity high density foam material) with extremely high impact absorbing performance is included in a layer form, and the high impact absorptivity high density foam material sufficiently absorbs the impact throughout the entire surface. As a result, in the martial arts equipment of the present invention, the required impact absorbing performance can be reliably performed on the impact of the blow without thickening the impact-reducing material and making the equipment body large and bulky. Thus, the martial arts equipment of the present invention appears slim and light and is light weight.

[0014] In one preferred embodiment of the present invention, one form of the impact-reducing material includes placing a high elastic foam material on a face (impact first delivered face) where impact involved in the blow is first delivered, and superimposing the high impact absorptivity high density foam material on a back face thereof.

[0015] According to the preferred embodiment, the impact is reliably received by the high elastic foam material stacked on the face (impact first delivered face) first receiving the impact involved in the blow in the high impact absorptivity high density foam material, and the impact is sufficiently absorbed with the high impact absorptivity high density foam material. That is, by reliably receiving the impact at the high elastic foam material, the impact involved in the blow is widely (by areas) transferred rather than locally (by points), consequently, the high impact absorptivity high density foam material is sufficiently absorbed by areas rather than by points. Therefore, the martial arts equipment of the present invention appears slim and light.

[0016] In another preferred embodiment of the present invention, one form of the impact-reducing material includes placing the high impact absorptivity high density foam material on a face (impact first delivered face) where impact involved in the blow is first delivered, and superimposing a high elastic foam material on a back face thereof.

[0017] According to the preferred embodiment, even if a heavy impact is delivered, the impact is sufficiently absorbed. If such configuration is used in for example, a punch mitt, the impact on the hand of the trainer is rebounded. The impact of the heavy blow is sufficiently absorbed and weakened by using both the high density foam

material and the high elastic foam material. The trainer is thus protected from getting injured.

[0018] In the preferred embodiment of the present invention, the high impact absorptivity high density foam material has an impact absorbing performance of ball rebound elasticity of 15% or below under a condition that a ball weight is 286 g and the height of fall is 50.8 cm.

[0019] According to the preferred embodiment, the high impact absorptivity high density foam material has a sufficient impact absorbing performance, and thus the martial arts equipment of the present invention appears sufficiently slim and sufficiently light. It is further preferable for the high impact absorptivity high density foam material to have an impact absorbing performance of ball rebound elasticity of 10% or below under the condition that a ball weight is 286 g and the height of fall is 50.8 cm.

[0020] In another preferred embodiment of the present invention, the thickness of the high impact absorptivity high density foam material is 20 to 45 mm, and the thickness of the high elastic foam material is 5 to 20 mm.

[0021] According to the preferred embodiment, the thickness of the high impact absorptivity high density foam material and the high elastic foam material is thickness suitable for reducing the impact of the blow inflicted by the fist or the leg, and thus a martial arts equipment of the present invention is suitable for martial arts activities in which one participant inflicts a blow to the other participant's body with the fist or the leg.

[0022] The high impact absorptivity high density foam material is preferably a high density poly-urethane foam.

[0023] The high density poly-urethane foam is a material having an extremely high elasticity, and even if the thickness of the high impact absorptivity high density foam material is reduced, the required impact reducing performance can be reliably obtained by the impact-reducing material. The martial arts equipment appearing slim and very light can be obtained.

[0024] A specific material of the high impact absorptivity high density foam material includes a Memory Foam invented by NASA (released by Yamamitsu Oil Co., Ltd.). The Memory Foam presents an extremely high impact absorbing performance of ball rebound elasticity of 5 to 10% (or impact absorptivity of 90 to 95%) compared to the conventional poly-urethane foam presenting an impact absorbing performance of impact absorptivity of about 70% to pressurization. The Memory Foam is a high density poly-urethane foam in which the resilience does not deteriorate even after being used over a long period of time, and in which the durability is high. The major features of the Memory Foam are as follows.

[0025] (1) Density: 0.096 g/cm³, Test method: ASTM D-3575

[0026] (2) Ball rebound elasticity: 5 to 10% (ball weight 286 g, height of fall 50.8 cm)

[0027] (3) Compression—deform compression rate: 25%, 0.053 to 0.105 kg/cm², Test method: ASTM D-3574

[0028] Compression—deform compression rate: 50%, 0.070 to 0.176 kg/cm², Test method: ASTM D-3574

[0029] (4) Compression permanent deformity: 0%, Test method: ASTM D-1564

[0030] (5) Tensile strength: 0.98 to 2.32 kg/cm², Test method: ASTM D-412

[0031] (6) Compression creep: 0%, 2 psi load 1000 hrs room temperature

[0032] (7) Elongation: 120 to 210%, Test method: ASTM D-412

[0033] (8) Tearing strength: 0.46 kg/cm², Test method: ASTM D-412

[0034] (9) Recovery speed: 2 to 4 minutes 2 hr 80% compression

[0035] Further, a specific material of the high elastic foam material includes a rubber elastic foam material such as soft poly-styrene elastomer cross-linked foam. This high elastic foam material is a material that has higher elasticity than the high impact absorptivity high density foam material. Since impact absorption is mainly performed by the high impact absorptivity high density foam material, the high elastic foam material need only to have an impact absorbing performance of impact absorptivity of about 70%.

[0036] In another preferred embodiment of the present invention, the martial arts equipment is a head gear including a gear body, serving as the equipment body, that is worn by the head of the participant, an opening for exposing the eyes of the wearer is formed at the front face of the gear body, and the front face as well as the sides of the gear body are filled with an impact-reducing material.

[0037] According to the present embodiment, such head-gear appears slim and light and is lightweight, and the impact on the head of the participant or the impact rebounded from the participant who inflicts the blow are sufficiently reduced by the impact-reducing material.

[0038] In another preferred embodiment of the above mentioned embodiment, a thin rigid material is provided between the high impact absorptivity high density foam material and the high elastic foam material in the impact-reducing material around the opening of the gear body.

[0039] According to such embodiment, the thin rigid material reinforces the high elastic foam material at the side of the impact first delivered face, and thus even if a greater blow is inflicted, the high elastic foam material will still withstand the blow, and widely (by areas) transfers the impact involved in such blow.

[0040] In another preferred embodiment of the present invention, the martial arts equipment is a punch mitt including a mitt body, serving as an equipment body, that is fitted to and worn by the hands of the trainer, practicing as an adversary, the front side of the mitt body is the impact receiving part, and a glove portion to which the trainer puts the hands into is provided at the back side of the mitt body, and substantially the entire mitt body is filled with an impact-reducing material.

[0041] According to such embodiment, the punch mitt appears slim and light and is lightweight, and the impact applied on the hand, elbow, and the shoulder of the trainer or the fist of the participant inflicting the punch is sufficiently reduced by the impact-reducing material of the mitt body.

[0042] In another preferred embodiment of the present invention, the martial arts equipment is a glove including a glove body, serving as an equipment body, that is worn by the hands of the participant, the overall shape of the glove body is formed into a glove shape that fits the hands of the participant, and the side in the glove body on the back of the hand is filled with an impact-reducing material.

[0043] According to such embodiment, the glove appears slim and light and is lightweight, and the impact applied on the fist of the participant inflicting the blow with the glove, or on the participant receiving the blow by the gloves is sufficiently reduced by the impact-reducing material of the glove body.

BRIEF DESCRIPTION OF THE DRAWINGS

[0044] FIG. 1 is a perspective view showing a headgear according to a first embodiment of the present invention;

[0045] FIG. 2 is a cross sectional view showing an inner structure of a front-face part of a gear body of the first embodiment;

[0046] FIG. 3 is a diagram explaining a layer structure of an impact-reducing material according to the first embodiment;

[0047] FIG. 4 is a perspective view showing a head gear according to a second embodiment of the present invention;

[0048] FIG. 5 is a side view showing the headgear according to the second embodiment;

[0049] FIG. 6 is a front view showing the headgear according to the second embodiment;

[0050] FIG. 7 is a diagram explaining a layer structure of an impact-reducing material of the second embodiment;

[0051] FIG. 8 is a plan view showing a punch mitt according to a third embodiment of the present invention;

[0052] FIG. 9 is a side view showing the punch mitt of the third embodiment;

[0053] FIG. 10 is a plan view showing an impact-reducing material of the third embodiment;

[0054] FIG. 11(a) is a diagram explaining a layer structure of the impact-reducing material of the third embodiment; and (b) is a diagram explaining a variant of (a);

[0055] FIG. 12 is a plan view showing a glove of a fourth embodiment of the present invention;

[0056] FIG. 13 is a side view of the glove according to the fourth embodiment;

[0057] FIG. 14 is a diagram explaining a layer structure of an impact-reducing material of the fourth embodiment;

[0058] FIG. 15 is a diagram explaining a layer structure of the impact-reducing material of the headgear according to the first embodiment; and

[0059] FIG. 16 is a diagram explaining a layer structure of the impact-reducing material of the glove according to the fourth embodiment.

DETAILED DESCRIPTION OF THE PREFERRED EMBODIMENTS

[0060] The configuration of the present preferred embodiment will now be explained.

First Embodiment

[0061] FIG. 1 is a perspective view showing a sport headgear (martial arts equipment) according to a first preferred embodiment of the present invention. The headgear in FIG. 1 includes a gear body (equipment body) 1 worn at the head of the participant. An opening 2 elongated in the left and right direction is formed at substantially the center of the front face of the gear body 1 to expose both eyes of the wearer. The hollow portion in the gear body 1 is filled entirely with an impact-reducing material 3. The headgear is worn by placing the gear body 1 on the head of the participant and tying the ends at the back of the head with strings 4.

[0062] The gear body 1 is made of a flexible skin material 1a such as an artificial leather material or a natural leather material, and is fabricated into a smooth shape so as to encompass the front and the sides of the face of the wearer. A bulging portion 1b is formed around the opening 2, excluding the lower central part right above where the nose is to be placed. The bulging portion 1b bulges out in the forward direction. The bulging portion 1b around the opening 2 of the gear body 1 is thickly filled with a high elastic foamed material, described later, and thus the surface of the gear body 1 is in a raised state. The surroundings of the eyes and nose can be reliably protected by this configuration.

[0063] A cheek protector occupying substantially the lower half of the gear body 1 discontinues in the left and the right side and thus is disconnected at the position of the ridge of the nose. The discontinuing lines are formed on an upper and lower side at the center of substantially the lower half of the gear body 1, but since such discontinuing lines are coupled by a strip-shaped piece 5 sewn thereto, the cheek protector does not open at such discontinuing lines and can reliably protect the nose and its surroundings. Further, the lower end side of the front face of the gear body 1 is formed by being gradually cut diagonally from the side toward the center in the upward direction to expose the mouth of the participant. Eardrum protectors 6 for protecting the ears of the participant are arranged in a circularly projecting manner on both sides the gear body 1.

[0064] The participant wearing the headgear on the head will have a sufficient view from the opening 2 in the front face of the gear body 1, and will be able to protect the nose as it is buried between the cheek protectors of the gear body 1. When the heavy blow is inflicted to a participant from the opposing participant, the impact involved in the heavy blow is reduced by the impact-reducing material 3, thus preventing the participant from getting injured, and also preventing the fist and the wrist of the opposing participant, who has inflicted the blow, from hurting. This allows a safe match or a practice to be pursued.

[0065] The impact-reducing material 3, one characteristic of the configuration of the headgear according to the first preferred embodiment, will now be discussed with reference to the figures. FIG. 2 is a cross sectional view showing an inner structure of the front face of the gear body 1, in which the gear body 1 is disconnected at the right and the left side at a position right above the opening 2. FIG. 3 is a view showing a layer structure of the impact-reducing material 3.

[0066] As shown in FIG. 2, in the headgear of the first preferred embodiment, the gear body 1 is filled with the

impact-reducing material **3**, which includes a high density foam material, having an extremely high impact absorbing performance (high impact absorbing high density foam material) **3A** in a layer form, and a high elastic foam material **3B** stacked on a face (impact first delivered face) first delivered with the impact involved in the blow to the high impact absorbing high density foam material **3A** (hereinafter referred to as high density foam material). An adhesive and the like is included between the high density foam material **3A** and the high elastic foam material **3B** to adhere the two materials. In case of the gear body **1** in the first preferred embodiment, in which the impact-reducing material **3** is thickly filled around the opening **2**, as mentioned above, an excessive high elastic foam material **3B** is filled by a thickness of the impact-reducing material **3** to suppress an increase in weight as much as possible.

[0067] Normally, in the impact-reducing material **3**, the high density foam material **3A** is high density poly-urethane foam having a thickness **d1** of 20 mm to 45 mm, and the high elastic foam material **3B** is a soft poly-styrene elastomer cross-linked foam having a thickness **d2** of 5 mm to 20 mm, in places where impact is applied, as shown in FIG. 3. In this case, the thickness of the high density foam material **3A** and the high elastic plastic material **3B** are thicknesses suitable for reducing the impact of the blow by the fist or the leg, and thus the headgear of the first preferred embodiment is also suitable for martial arts activities such as boxing, karate, and taekwondo in which one participant inflicts a blow to the other participant's body with the fist or the leg.

[0068] An example of a specific high density poly-urethane foam of the high density foam material **3A** includes a NASA invented Memory Foam, as mentioned before, and an example of a specific soft poly-styrene elastomer cross-linked foam of the high elastic foam material **3B** includes a Pita Foam (trade name, manufactured by Daiichi Chemicals Co., Ltd.).

[0069] In case of the impact-reducing material **3** configured as above, the high elastic foam material **3B**, to where the impact involved in the blow is first applied, has a sufficient elasticity, does not easily dent even if the impact is delivered, does not transfer the impact involved in the blow, and widely transfer rather than locally transfer the impact involved in the blow to the high density foaming material **3A** in the next layer. The high density foam material **3A** reliably absorbs the impact not by points but by areas, and thus even a large impact involved in the heavy blow can be sufficiently reduced. The headgear of the first preferred embodiment has a slim and light appearance and is light weight. In addition, in the first preferred embodiment, the impact absorbing performance of the high density poly-urethane foam or the high density foam material **3A** is very high, and thus the required impact-reducing performance can be reliably performed by the impact-reducing material **3** even if the thickness of the impact-reducing material **3** is reduced. The headgear thus appears to be slim and light and becomes light weight.

EXAMPLES

[0070] A specific example according to the headgear in the first preferred example will now be explained. In the following examples, three types of Memory Foam **3A1** to **3A3** of different grades with thickness of about 5 mm are

additionally used as the high density foam material **3A**. A Pita Foam **3B1** of thickness of about 5 mm is used as the high elastic foam material **3B**. An artificial leather (trade name: SOFRINA) is used as the skin material **1a**.

[0071] (a) Memory Foam **3A1**

[0072] (1) Density: 0.096 g/cm³, Test method: ASTM D-3575

[0073] (2) Ball rebound elasticity: 5% (ball weight 286 g, height of fall 50.8 cm)

[0074] (3) Compression—deform compression rate: 25%, 0.141 kg/cm², Test method: ASTM D-3574

[0075] Compression—deform compression rate: 50%, 0.176 kg/cm², Test method: ASTM D-3574

[0076] (4) Compression permanent deformity: 0%, Test method: ASTM D-1564

[0077] (5) Tensile strength: 2.32 kg/cm², Test method: ASTM D-412

[0078] (6) Compression creep: 0%, 2 psi load 1000 hrs room temperature

[0079] (7) Elongation: 120%, Test method: ASTM D-412

[0080] (8) Tearing strength: 0.81 kg/cm², Test method: ASTM D-412

[0081] (9) Recovery speed: 4 minutes 2hr 80% compression

[0082] (10) Rigidity: hard (harder in high elastic foam material **3B**)

[0083] (b) Memory Foam **3A2**

[0084] (1) Density: 0.096 g/cm³, Test method: ASTM D-3575

[0085] (2) Ball rebound elasticity: 10% (ball weight 286 g, height of fall 50.8 cm)

[0086] (3) Compression—deform compression rate: 25%, 0.105 kg/cm², Test method: ASTM D-3574

[0087] Compression—deform compression rate: 50%, 0.134 kg/cm², Test method: ASTM D-3574

[0088] (4) Compression permanent deformity: 0%, Test method: ASTM D-1564

[0089] (5) Tensile strength: 1.54 kg/cm², Test method: ASTM D-412

[0090] (6) Compression creep: 0%, 2 psi load 1000 hrs room temperature

[0091] (7) Elongation: 155%, Test method: ASTM D-412

[0092] (8) Tearing strength: 0.46 kg/cm², Test method: ASTM D-412

[0093] (9) Recovery speed: 3 minutes 2hr 80% compression

[0094] (10) Rigidity: softish.

- [0095] (c) Memory Foam **3A3**
- [0096] (1) Density: 0.096 g/cm³, Test method: ASTM D-3575
- [0097] (2) Ball rebound elasticity: 10% (ball weight 286 g, height of fall 50.8 cm)
- [0098] (3) Compression—deform compression rate: 25%, 0.053 kg/cm², Test method: ASTM D-3574
- [0099] Compression—deform compression rate: 50%, 0.070 kg/cm², Test method: ASTM D-3574
- [0100] (4) Compression permanent deformity: 0%, Test method: ASTM D-1564
- [0101] (5) Tensile strength: 1.19 kg/cm², Test method: ASTM D-412
- [0102] (6) Compression creep: 0%, 2 psi load 1000 hrs room temperature
- [0103] (7) Elongation: 170%, Test method: ASTM D-412
- [0104] (8) Tearing strength: 0.32 kg/cm², Test method: ASTM D-412
- [0105] (9) Recovery speed: 2 minutes 2hr 80% compression
- [0106] (10) Rigidity: soft
- [0107] (d) Pita Foam **3B1**
- [0108] (1) Apparent density: 0.088 g/cm³ Test method JIS K6767 test piece: JIS B-type
- [0109] (2) Tensile strength: 120 N/cm², Test method: JIS K 6767 appendix A, test piece JIS-1
- [0110] (3) Elongation: 210%, Test method: JIS K 6767 appendix A, test piece JIS-1
- [0111] (4) Tearing strength: 21 N/cm, Test method: JIS K 6767, test piece JIS B-type
- [0112] (5) Compression permanent distortion rate: 4.4%, Test method: JIS K 6767 appendix A, test piece JIS-1
- [0113] (6) Compressive strength: 25% compression, 2.8 N/cm², Test method: JIS K 6767 B method
- [0114] (7) Rebound resilience: 26% in accordance with Test method: JIS K 6767-1995

Example a

[0115] The headgear of example a includes the impact-reducing material **3** of Memory Foam **3A1**, **3A2** and Pita Foam **3B1** stacked in layers, as shown in **FIG. 15(a)**.

Example b

[0116] The headgear of example b includes the impact-reducing material **3** of Memory Foam **3A1** to **3A3** and Pita Foam **3B1** stacked in layers, as shown in **FIG. 15(b)**.

Example c

[0117] The headgear of example c includes the impact-reducing material **3** of Memory Foam **3A1** and **3A2** and Pita Foam **3B1** stacked in layers, as shown in **FIG. 15(c)**.

[0118] In order to check the impact-reducing performance of the impact-reducing material **3** of the headgear in

examples a to c, a dynamic compression test is performed on the Memory Foam **3A1** to **3A3** and the Pita Foam **3B1** in respect to the stacked layer test piece of length 130 mm and width 90 mm, as shown in **FIG. 15(a)** to **FIG. 15(c)**. The test method is performed in accordance with JIS Z0235, the testing apparatus is a vertical drop type, and the acceleration as well as the process time of when a 5.8 kg of weight is dropped from a height of 60 cm are measured. The measurement is carried out twice with the time interval of 5 minutes. As a comparative example, similar test is performed on the impact-reducing material of thickness 50 mm of the conventional commercially available headgear (FG-3000 manufactured by Winning USA). The measurement results are shown in table 1.

TABLE 1

		Acceleration (m/s ²)	Process time (ms)	Weight (g)	thickness (mm)
Example a	First	366	18.7	44	41
	second	373	19.2		
Example b	First	377	19.7	44	40
	second	402	19.7		
Example c	First	414	17.4	38	34
	second	441	17.2		
Comparative example	First	854	14.2	54	50
	second	872	14.6		

[0119] Referring to table 1, by comparing the examples a to c with the comparative example, the impact-reducing material **3** of the examples a to c using the Memory Foam **3A1** to **3A3** has an acceleration not more than half of that of the comparative example, and thus is numerically shown that the impact-reducing performance is improved. Furthermore, each example is lighter in weight and smaller in thickness compared to the comparative example.

Second Example

[0120] **FIG. 4** is a perspective view showing a sport head gear (martial arts equipment) according to a second preferred example of the present invention. The cheek protectors of the gear body **7** of the headgear shown in **FIG. 4** are connected at the position of the ridge of the nose without discontinuing to the left and the right side. The cheek protectors are bent so as to maximally project forward at the position of the ridge of the nose, as shown in **FIG. 5**. Further, a thin rigid material **10** is provided in the impact-reducing material **9** around the opening **8** of the gear body **7**, as shown in **FIG. 6**. Other features of the headgear besides the features mentioned above are essentially the same as the headgear of the first preferred example, and thus only the differences between the two preferred examples will be explained. In **FIGS. 5** to **7**, similar reference characters denote similar elements throughout the figures.

[0121] Referring to **FIG. 7**, in the impact-reducing material **9** of the second preferred example, the area filled with the rigid material **10** includes three layers consisting of high density foam material **9A**, high elastic foam material **9B**, and rigid material **10** in between the foam materials **9A** and **9B**, which layers are stacked one over the other. At the area not filled with the rigid material **10**, the impact-reducing material **9** is thinner by the thickness of the rigid material **10**. The thin rigid material **10** includes a light metal thin plate such as aluminum and a hard plastic thin plate, and further

includes a steel line or a bar material, and an iron material such as a thin plate material. In case of a steel line or a bar material, the diameter is preferably in a range of about 3 to 7 mm.

[0122] According to the headgear of the second preferred example, the high elastic foam material 3B on the side of the impact delivered face is deposited with a thin rigid material 10, and thus even if a heavy blow is delivered, the high elastic foam material 3B bears and sufficiently reduces the impact.

Third Example

[0123] FIG. 8 is a plan view showing a punch mitt according to a third preferred example of the present invention, and FIG. 9 is a side view of the punch mitt according to the third preferred example. The punch mitt shown in FIG. 8 and FIG. 9 includes a mitt body (equipment body) 11 worn on the hands of the trainer of an activity practicing as an adversary. The front side of the mitt body 11 is the blow receiving part 12, and the back side of the mitt body 11 includes a glove portion 13, where the trainer puts the hands into. An impact-reducing material 14 is filled throughout the entire mitt body 11. The mitt body 11 uses a flexible skin material 11a such as an artificial leather material and a natural leather material and is smoothly finished to a substantially oval shape having a size larger than the flat of a hand of the wearer. The central part of the blow receiving part 12 on the front side of the mitt body 11 is curved into a concave shape.

[0124] When the trainer performs a practice using the punch mitt of the third preferred example, the trainer puts the hands into the glove portion 13 on the back side of the mitt body 11, holds up the front side of the mitt body 11 so that it faces the opposing trainee, and receives the blow inflicted by the trainee. The blow can be more easily received when the central part of the blow receiving part 12 of the mitt body 11 is curved as in the punch mitt of the third preferred example, and in boxing, for example, punches such as an upper punch can be received without fail.

[0125] When the trainer receives the blow from the trainee at the blow receiving part 12 of the mitt body 11, the burden on the elbow and the shoulder of the trainer is reduced, and the fist as well as the wrist of the trainee will not be injured since the impact of the blow is absorbed and reduced by the impact-reducing material 14. The practice can thus be carried out safely.

[0126] The impact-reducing material 14, one characteristic of a configuration of the punch mitt of the third example will now be specifically explained with reference to the figures. FIG. 10 is a plan view of the impact-reducing material 14 seen from the front side, and FIG. 11 is a diagram explaining the layer structure of the impact-reducing material of the third preferred example. Here, the skin material of for example, leather and cloth cover is omitted.

[0127] As shown in FIG. 10 and FIG. 11(a), the impact-reducing material 14 is two-layer structured consisting of a high elastic foam material 14B and a high density foam material 14A superimposed on the front side face or the impact delivered face of the high elastic foam material 14B. In case of the impact-reducing material 14, the high elastic foam material 14B is formed with a recess of a shape similar

to the plan shape of the high density foam material 14A with the periphery slightly remaining, and the high density foam material 14A is fitted into the recess. The high density foam material 14A and the high elastic foam material 14B are adhered together with an adhesive provided in between.

[0128] In case of the impact-reducing material 14, the thickness of the high density foam material 14A is 10 to 20 mm, and the thickness of the high elastic foam material 14B is 20 to 45 mm. In this case, the thickness of the high density foam material 14A and the high elastic foam material 14B is suitable for reducing the impact of the blow by the fist or the leg. The punch mitt of the present preferred example is thus suitable for martial arts activities in which one participant inflicts a blow to the other participant's body with the fist or the leg. Further, an example of the high density foam material 14A includes a Memory Foam cited in the first preferred example, and an example of the high elastic foam material 14B includes a Pita Foam cited in the first preferred example.

[0129] In the impact-reducing material 14 having the above configuration, the high density foam material 14A acting as the receiving face sufficiently absorbs the impact, rebounds the impact on the hand of the trainer, and the impact of the heavy blow is sufficiently absorbed and weakened with both the high density foam material 14A and the high elastic foam material 14B. As a result, according to the punch mitt of the third preferred example, the required impact-reducing performance with respect to the impact involved in the blow can be reliably performed without thickening the impact-reducing material 14 and forming the mitt body 11 large and bulky. Thus, the punch mitt of the third preferred example includes a mitt body 11 that appears slim and light and is lightweight.

[0130] As a variant, the punch mitt having the configuration shown in FIG. 11(a) may be replaced by a configuration shown in FIG. 11(b). The punch mitt shown in FIG. 11(b) differs from that shown in FIG. 11(a) in that the high elastic foam material 14B is arranged on the impact delivered face, the high density foam material 14A is arranged in the middle, and the high elastic foam material 14B is again arranged on the back face side. Such punch mitt immediately causes rebound action to the given blow and is thus suitable for practices involving multiple light blows that are repeatedly and rapidly inflicted. Preferably, the high elastic foam material 14B of the impact receiving face has a thickness of 5 to 30 mm, the high density foam material in the middle part has a thickness of about 10 to 20 mm, and the high elastic foam material 14B on the back face side has a thickness of about 5 to 30 mm.

Fourth Example

[0131] FIG. 12 is a plan view showing a sport glove (martial arts equipment) according to a fourth preferred example of the present invention, and FIG. 13 is a side view of the glove of the third preferred example. The glove shown in FIG. 12 and FIG. 13 includes a glove body (equipment body) 15 fitted to and worn by the hands of the participant. The entire glove body is shaped so that it fits the hand of the participant, and the side of the back of the hand of the glove body 15 is filled with an impact-reducing material 16. The glove body 15 of the glove of the fourth preferred example uses a flexible skin material 15a such as an artificial leather

material or a natural leather material and is smoothly finished to suit the size and shape of the fist of the participant.

[0132] When the participant participates in a match or a practice using the glove of the fourth example, the participant fits the hands into the glove body 15, clenches the hands to make a fist, and heads the glove to the other participant. The impact involved in the blow when the glove hits the other participant is absorbed and reduced by the impact-reducing material 16, and the fist as well as the wrist of the participant who has inflicted the blow will not be hurt. The participant hit by the blow can avoid being injured and thus a match or a practice can be pursued safely.

[0133] The impact-reducing material 16, one characteristic of a configuration of the glove of the fourth preferred example will now be specifically explained with reference to the figures. FIG. 14 is a diagram showing a layer structure of an impact-reducing material 16.

[0134] In the glove of the fourth example, the glove body 15 is filled with the impact-reducing material 16, which is two-layer structured consisting of high density foam material 16A, and a high elastic foam material 16B stacked on the front side face, acting as the impact receiving face, of the high density foam material 16A, as shown in FIG. 14. With regards to the impact-reducing material 16, the high density foam material 16A and the high elastic foam material 16B are filled so that generally the entire back of the hand of the glove body 15 is doubly covered with both the high density foam material 16A and the high elastic foam material 16B. The high density foam material 16A and the high elastic foam material 16B are adhered together with an adhesive and the like provided in between.

[0135] In case of the impact-reducing material 16A, the thickness of the high density foam material 16A is 20 to 45 mm, and the thickness of the high elastic foam material 16B is 5 to 15 mm. In this case, the thickness of the high density foam material 16A and the high elastic foam material 16B is suitable for reducing the impact of the blow by the fist or the leg. The glove of the fourth example is thus suitable for martial arts such as boxing, karate and taekwondo in which one participant inflicts a blow to the other participant's body with the fist of the leg. Further, an example of the high density foam material 16A includes a Memory Foam cited in the first preferred example, and an example of the high elastic foam material 16B includes a Pita Foam cited in the first preferred example.

[0136] The impact-reducing material 16 having the above configuration, suppresses the impact involved in the blow from passing through the high elastic foam material 16B, and widely transfers the impact to the high density foam material 16A. The high density foam material 16A and the high elastic foam material 16B sufficiently absorb and weaken the impact of the heavy blow. As a result, according to the glove of the fourth example, the required impact-reducing performance with respect to the impact involved in the blow can be reliably performed without thickening the impact-reducing material 16 and making the glove body 15 large and bulky. Thus, the glove of the fourth preferred example includes a glove body 15 that appears slim and light and is lightweight.

EXAMPLES

[0137] A specific example A according to a glove of the fourth preferred example will now be explained. In the

following example, the previously mentioned Memory Foam 3A1 and 3A3 and the following Memory Foam 3A4 of different grades with thickness of about 5 mm are used as the high density foam material 16A. The Pita Foam 3B1 with thickness of about 5 mm is used as the high elastic foam material 16B. An artificial leather (Sofrina) is used as the skin material 15a.

[0138] (A) Memory Foam 3A4

[0139] (1) Density: 0.096 g/cm³, Test method: ASTM D-3575

[0140] (2) Ball rebound elasticity: 10% (ball weight 286 g, height of fall 50.8 cm)

[0141] (3) Compression—deform compression rate: 25%, 0.053 kg/cm², Test method: ASTM D-3574

[0142] Compression—deform compression rate: 50%, 0.070 kg/cm², Test method: ASTM D-3574

[0143] (4) Compression permanent deformity: 0%, Test method: ASTM D-1564

[0144] (5) Tensile strength: 0.98 kg/cm², Test method: ASTM D-412

[0145] (6) Compression creep: 0%, 2 psiw load 1000 hrs room temperature

[0146] (7) Elongation: 210%, Test method: ASTM D-412

[0147] (8) Tearing strength: 0.25 kg/cm², Test method: ASTM D-412

[0148] (9) Recovery speed: 2 minutes 2 hr 127° C. (no load)

[0149] (10) Rigidity: very soft

Example A

[0150] The glove of example A includes an impact-reducing material 16 consisting of Memory foam 3A1, 3A3, 3A4 as well as the Pita Foam 3B1 stacked thereon, as shown in FIG. 16. In order to check the impact-reducing performance of the impact-reducing material 16 of the glove in example A, a dynamic compression test is performed on the Memory Foam 3A1, 3A3, 3A4 and the Pita Foam 3B1 in respect to the stacked layer test piece of length 130 mm and width 90 mm, as shown in FIG. 16. The test method is performed in accordance with JIS Z0235, the testing apparatus is a vertical drop type, and the acceleration and the process time of when a 5.8 kg of weight is dropped from a height of 60 cm are measured. The measurement is carried out twice with the time interval of 5 minutes. As a comparative example, similar test is performed on the impact-reducing member of thickness 45 mm of the commercially available glove (trade name: MS-500 manufactured by Winning USA). The measurement results are shown in table 2.

TABLE 2

		Acceleration (m/s ²)	Process time (ms)
Example A	First	464	20.1
	second	527	18.9
Comparative example	First	1520	8.2
	second	1650	7.6

[0151] Referring to table 2, by comparing the example A with the comparative example, the impact-reducing member 16 of the example A using the Memory Foam 3A1, 3A3, 3A4 has an acceleration less than half of that of the comparative example, and thus is apparent that the impact-reducing performance is improved.

Another Example

[0152] (1) In each of the above mentioned example, polyurethane foam material Memory Foam is used as the high density foam material and Pita Foam is used as the high elastic foam material constituting the impact-reducing material, but other EGR material (e.g., manufactured by INOAC CORPORATION) with low ball rebound elasticity may also be used, and materials other than the poly-urethane material may also be used as long as the material has high impact absorbability and low ball rebound elasticity. The EGR, especially, is not readily hardened even in low temperature and thus is suited for use in cold places. In the high density foam material such as the above Memory Foam, as well, disadvantages caused by low temperature does will not arise since such material is closely fitted to the body during practice or during match and is subjected to body heat transfer.

[0153] (2) In the first preferred example, the discontinued part of the gear body 1 is coupled with a strip-shaped piece, but the discontinued part of the gear body 1 may not necessarily be coupled with a strip-shaped piece and a headgear having a configuration similar to the headgear in the first preferred example but with the discontinued part left in a discontinued state may also be proposed as another example.

[0154] (3) As a variant of the glove of the fourth preferred example shown in FIG. 12 to FIG. 14, the glove may be a type protecting each finger. Further, the glove may be an open finger type glove in which the tip of each finger is exposed. In either type, in accordance with the configuration of the present invention, the impact absorptivity is large and is also light in weight.

1. A martial arts equipment comprising an equipment body that is worn by a participant during match or during practice of a martial arts activity in which one participant inflicts a blow on another participant's body, and is filled with an impact-reducing material at places where an impact involved in the blow is delivered; wherein

the impact-reducing material includes a high impact absorptivity high density foam material having an excellent impact absorbing performance in a layer form.

2. The martial arts equipment as claimed in claim 1, wherein the impact-reducing material has a layer structure consisting of a high elastic foam material on a face (impact first delivered face) where the impact involved in the blow is first delivered, and the high impact absorptivity high density foam material on a back face side thereof.

3. The martial arts equipment as claimed in claim 1, wherein the impact-reducing material has a layer structure consisting of the high impact absorptivity high density foam material on a face (impact first delivered face) where the

impact involved in the blow is first delivered, and a high elastic foam material on a back face side thereof.

4. The martial arts equipment as claimed in claim 1, wherein the high impact absorptivity high density foam material has an impact absorbing performance of ball rebound elasticity of 15% or below under a condition that a ball weigh is 286 g and a height of fall is 50.8 cm.

5. The martial arts equipment as claimed in claim 1, wherein the martial arts equipment is a headgear including a gear body, serving as the equipment body, placed on and worn by the head of a participant, and wherein

an opening for exposing an eye part of the wearer is formed on a front face of the gear body, and the front face as well as sides of the gear body are filled with the impact-reducing material.

6. The martial arts equipment as claimed in claim 5, wherein the impact-reducing material includes a thin rigid material placed between the high impact absorptivity high density foam material and the high elastic foam material at around the opening of the gear body.

7. The martial arts equipment as claimed in claim 1, wherein the martial arts equipment is a punch mitt including a mitt body, serving as the equipment body, fitted to and worn by the hand of a trainer performing as the opposing participant, wherein

a front side of the mitt body acts as an impact receiving side, and a back side of the mitt body is provided with a glove portion to which the trainer puts the hand into; and

substantially the entire mitt body is filled with the impact-reducing material.

8. The martial arts equipment as claimed in claim 1, wherein the martial arts equipment is a glove including a glove body, serving as the equipment body, fitted to and worn by the hand of the participant, wherein

an overall shape of the glove body is formed into a glove shape that fits the hand of the participant; and

a side in the glove body of the back of the hand is filled with the impact-reducing material.

9. A martial arts protection equipment comprising a laminated pad having at least two layers, wherein an outer layer is made of a rubber elastic foam material and an inner layer is made of an impact absorptivity foam material, said impact absorptivity foam material having a ball rebound elasticity of about 5-10% as measured when a ball weight of 286 g falls from a height of 50.8 cm, said rubber elastic foam material having a higher rebound elasticity than the impact absorptivity foam material.

10. The martial arts protection equipment according to claim 9, wherein the impact absorptivity foam material is a high-density urethane foam.

11. The martial arts protection equipment according to claim 9, wherein the rubber elastic foam material is a soft poly-styrene elastomer cross-linked foam.

12. The martial arts protection equipment according to claim 9, wherein the pad further comprises a thin rigid material between the outer layer and the inner layer.