



## INTERNATIONAL APPLICATION PUBLISHED UNDER THE PATENT COOPERATION TREATY (PCT)

(51) International Patent Classification <sup>7</sup> : H01P 3/08	A1	(11) International Publication Number: WO 00/62368 (43) International Publication Date: 19 October 2000 (19.10.00)
--	----	---

(21) International Application Number: PCT/FI00/00274

(22) International Filing Date: 30 March 2000 (30.03.00)

(30) Priority Data:  
990717 31 March 1999 (31.03.99) FI

(71) Applicant (for all designated States except US): NOKIA NETWORKS OY [FI/FI]; P.O. Box 300, FIN-00045 Nokia Group (FI).

(72) Inventor; and

(75) Inventor/Applicant (for US only): SALMELA, Olli [FI/FI]; Pajalahdentie 9 B 35, FIN-00200 Helsinki (FI).

(74) Agent: OULUN PATENTTITOIMISTO; Berggren OY AB, Teknologiantie 14D, FIN-90570 Oulu (FI).

(81) Designated States: AE, AG, AL, AM, AT, AU, AZ, BA, BB, BG, BR, BY, CA, CH, CN, CR, CU, CZ, DE, DK, DM, DZ, EE, ES, FI, GB, GD, GE, GH, GM, HR, HU, ID, IL, IN, IS, JP, KE, KG, KP, KR, KZ, LC, LK, LR, LS, LT, LU, LV, MA, MD, MG, MK, MN, MW, MX, NO, NZ, PL, PT, RO, RU, SD, SE, SG, SI, SK, SL, TJ, TM, TR, TT, TZ, UA, UG, US, UZ, VN, YU, ZA, ZW, ARIPO patent (GH, GM, KE, LS, MW, SD, SL, SZ, TZ, UG, ZW), Eurasian patent (AM, AZ, BY, KG, KZ, MD, RU, TJ, TM), European patent (AT, BE, CH, CY, DE, DK, ES, FI, FR, GB, GR, IE, IT, LU, MC, NL, PT, SE), OAPI patent (BF, BJ, CF, CG, CI, CM, GA, GN, GW, ML, MR, NE, SN, TD, TG).

**Published***With international search report.**Before the expiration of the time limit for amending the claims and to be republished in the event of the receipt of amendments.**In English translation (filed in Finnish).*

(54) Title: INVERTED MICROSTRIP TRANSMISSION LINE INTEGRATED IN A MULTILAYER STRUCTURE

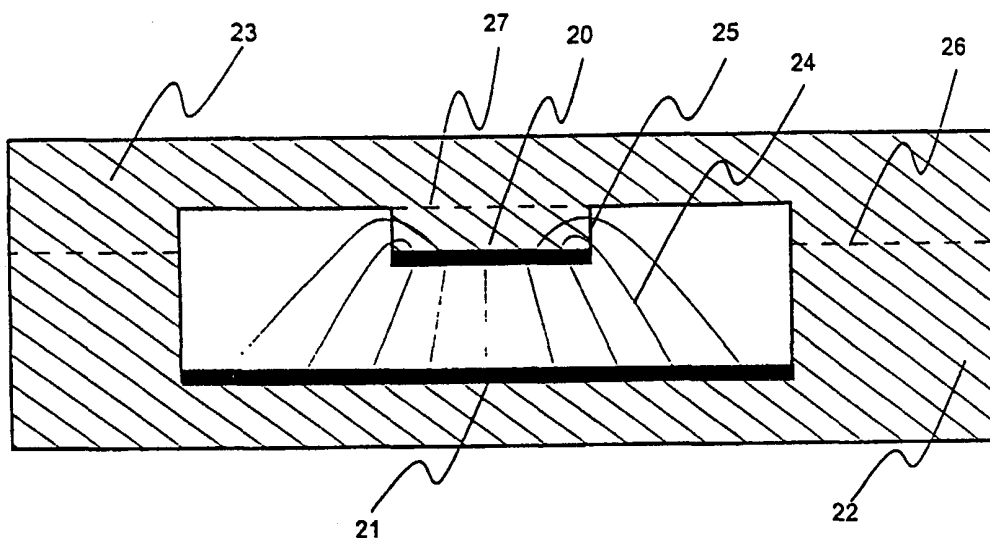

## (57) Abstract

The invention relates to a transmission cable realised by multilayer technique, where the signal cable (20) is set at a desired distance from the wall of the cavity constructed for said transmission cable by means of a separate support element (25). The ground cable (21) included in the structure is placed on the cable cavity wall opposite to the signal cable. By using the transmission cable according to the invention, there is achieved a low attenuation per unit of length at RF frequencies.

*FOR THE PURPOSES OF INFORMATION ONLY*

Codes used to identify States party to the PCT on the front pages of pamphlets publishing international applications under the PCT.

AL	Albania	ES	Spain	LS	Lesotho	SI	Slovenia
AM	Armenia	FI	Finland	LT	Lithuania	SK	Slovakia
AT	Austria	FR	France	LU	Luxembourg	SN	Senegal
AU	Australia	GA	Gabon	LV	Latvia	SZ	Swaziland
AZ	Azerbaijan	GB	United Kingdom	MC	Monaco	TD	Chad
BA	Bosnia and Herzegovina	GE	Georgia	MD	Republic of Moldova	TG	Togo
BB	Barbados	GH	Ghana	MG	Madagascar	TJ	Tajikistan
BE	Belgium	GN	Guinea	MK	The former Yugoslav Republic of Macedonia	TM	Turkmenistan
BF	Burkina Faso	GR	Greece	ML	Mali	TR	Turkey
BG	Bulgaria	HU	Hungary	MN	Mongolia	TT	Trinidad and Tobago
BJ	Benin	IE	Ireland	MR	Mauritania	UA	Ukraine
BR	Brazil	IL	Israel	MW	Malawi	UG	Uganda
BY	Belarus	IS	Iceland	MX	Mexico	US	United States of America
CA	Canada	IT	Italy	NE	Niger	UZ	Uzbekistan
CF	Central African Republic	JP	Japan	NL	Netherlands	VN	Viet Nam
CG	Congo	KE	Kenya	NO	Norway	YU	Yugoslavia
CH	Switzerland	KG	Kyrgyzstan	NZ	New Zealand	ZW	Zimbabwe
CI	Côte d'Ivoire	KP	Democratic People's Republic of Korea	PL	Poland		
CM	Cameroon	KR	Republic of Korea	PT	Portugal		
CN	China	KZ	Kazakstan	RO	Romania		
CU	Cuba	LC	Saint Lucia	RU	Russian Federation		
CZ	Czech Republic	LI	Liechtenstein	SD	Sudan		
DE	Germany	LK	Sri Lanka	SE	Sweden		
DK	Denmark	LR	Liberia	SG	Singapore		
EE	Estonia						

## Inverted microstrip transmission line integrated in a multilayer structure

The invention relates to a transmission cable constructed by multilayer technique, said cable being located in a cavity with a first surface and a second surface essentially parallel to the first, said transmission cable consisting of a signal cable that is essentially parallel with the first surface of the cavity, and of a ground cable that is placed on said second surface, essentially in parallel with the signal cable.

Various different cable structures are utilised in the construction of electronic appliances. The higher the employed frequencies, the higher the requirements set for the cable structures to be used, in order to prevent attenuation caused by said cable structures. At present, in the structures of electronic appliances, there is generally applied the so-called multilayer technique, which is based either on the HTCC technique (High Temperature Cofired Ceramics) or on the LTCC technique (Low Temperature Cofired Ceramics). With both manufacturing methods, the produced structures consist of several green tapes, with a thickness of about 100  $\mu\text{m}$ , which are positioned one on top of the other. Prior to thermal treatment, the material still is soft, so that in the green tapes, there can be made cavities of desired shapes. Likewise, at desired spots, there can be silk-screened various electrically passive elements. The elastic layers are laminated together by means of pressure. In order to prevent the lamination pressure from collapsing the structure that contains various cavities, the pressurising must be carried out according to a so-called uniaxial method. This means that the pressure is directed to the object only in the direction of the axis z of said object. Finally the created structure is burnt, in the case of LTCC at 850 degrees and in the case of HTCC at 1,600 degrees. In the elements to be produced, at the cavities there are made perforations through which the excess pressure created in the burning process can be let out.

In figures 1a and 1b, there is illustrated a possible alternative for realising an inverted microstrip cable based on the HTCC or LTCC multilayer technique according to the description above. In a preferred embodiment, the structure according to figure 1a is achieved by joining together, during the production process but prior to the burning step of the structure, the exemplary elements 12 and 13 illustrated in the drawing. Both of said elements are made layer by layer of some suitable dielectric material in a fashion described above. In the element 13, there is machined a rectangular groove, on the bottom of which there is silk-screened a signal cable 10. The thickness 18 of the element 13, when measured at

the bottom of the groove, is sufficient to prevent disturbing ground potential levels from coming close to the described inverted microstrip cable. In the example illustrated in the drawing, the angle between the side walls of the groove made in the element 13 and the groove bottom 16, 17 is 90 degrees, but in principle the angles can have some other size, too. On the surface of the element 12, there is silk-screened a ground cable 11, the width whereof corresponds to the width of the groove made in the element 13. The elements 12 and 13 are machined separately, and when they are connected, there is obtained a structure according to figure 1a, where there is created a gas-filled cable cavity 14.

10 In figure 1b, there is illustrated a cross-section made in the direction A - A' of figure 1a. The attenuation and impedance of a transmission cable according to the invention are determined by the permittivity ( $\epsilon_r$ ) of the employed elements 12 and 13, as well as the geometric shape of the groove. From the drawing it is seen that the electromagnetic field emitted from the signal cable 10, said field in the drawing being illustrated by the power lines 15, proceeds a long way inside the element 13. With RF frequencies, the permittivity of the element 13 is clearly higher than the permittivity of the gas mixture filling the cable cavity 14. This results in that the cable attenuation is strongly increased with RF frequencies. The final multilayer structure of the apparatus also includes other material layers than those illustrated in figures 1a and 1b, in which layers there may be provided passive components, cavities for active components and other cable structures, too.

However, the use of electric circuits manufactured by the above described techniques becomes problematic, if very high frequencies must be used (RF applications). Signal attenuation in a cable structure realised with LTCC technique at the frequency of 20 GHz rises up to 0,2 dB/cm, and in a cable structure realised with HTCC technique up to 0,6 dB/cm. In such RF applications where low attenuation is required, for example in filters and oscillation sources having a high quality factor (Q value), the above described techniques are no longer feasible.

Another problem with regular microstrip cables or inverted microstrip cables is the impedance level of the transmission cables realised by means of structures. An uncontrolled fluctuation of the impedance level results in undesired reflections of the signal back in the direction where the signal came from, or in radiation in the cable surroundings. Impedance is affected by the geometric shape of the cable structure, as well as by the relative permittivity ( $\epsilon_r$ ) of the surrounding material layers. In prior art structures, the above described two factors are the only free choices for adjusting the impedance.

With prior art LTCC and HTCC structures, another drawback is presented in the dispersion of the phase velocity with high frequencies. In a dispersed signal, the signal components contained therein at different frequencies have passed through the transmission cable at different velocities. This phenomenon distorts the received signal, and an excessive increase of the dispersion results in that the received signal becomes inapplicable.

From the US patent publication 3,904,997 there is known an arrangement where the signal cable of an inverted microstrip resting on a substrate is encased in a shell-like structure made of metal. By means of this arrangement, both the attenuation of the transmission cable and the stray radiation scattered from the cable are attempted to be reduced. The metallic cable cavity must always be manufactured in advance, and its fastening in a reliable way to the rest of the multilayer structure causes problems. The fact that the thermal expansion coefficient of the metallic cable cavity is different from the basic substrate may cause the structure to break at the junction surface. Moreover, the structure includes a lot of manually performed work steps, wherefore it also is expensive in manufacturing costs.

From the US patent publication 5,105,055 there is known an arrangement where in one flexible, cable-like structure there are integrated several cables. In said structure, the signal cable is attached to a dielectric substrate, and the ground cable is placed in a cavity-like structure made of another dielectric material. In principle, said cable is an entity made of several inverted microstrip cables. The materials of the cable structure are chosen among such materials that are elastic, and they can be processed with extrusion devices designed for processing plastics. Several variations of the cable structure are presented in the publication. According to said publication, the cable is meant to be used in connection with personal PC devices. Also in this case it is pointed out that owing to the target of usage, the materials chosen in the structure do not enable the use of RF frequencies.

The object of the invention is to reduce the described drawbacks connected to the prior art.

The transmission cable placed in a cavity according to the invention is characterised in that it comprises a support element with a surface essentially parallel to the first and second surfaces of the cavity, said support element being placed between said first and second surfaces, so that the signal cable is realised by

means of an electroconductive material layer formed on the surface of said support element.

A number of preferred embodiments of the invention are set forth in the independent claims.

5 The basic principle of the invention is as follows: by applying multilayer technique, there is manufactured a modified, inverted microstrip cable, where the signal cable is attached, by means of a specially designed support element, on one surface of the cable cavity. Thus the effect of the material layers that encase the cable to the electromagnetic field surrounding said cable is remarkably reduced.

10 An advantage of the invention is that at RF frequencies the attenuation of a transmission cable according to the invention is clearly lower than with existing inverted microstrip cables, because the electromagnetic field emitted from the signal cable is mainly located in the gas-filled cable cavity, the permittivity ( $\epsilon_r$ ) of said cable cavity with respect to the permittivity of the surrounding dielectric  
15 materials being low.

Another advantage of the invention is that the transmission cable can be fully integrated in a multilayer structure without any specific work steps carried out expressly for this purpose.

20 Yet another advantage of the invention is that thereby the impedance level of the transmission cable can be adjusted as desired in a simple fashion.

The invention is explained in more detail below. The description refers to the accompanying drawings, wherein

figure 1a shows in a perspective illustration a prior art inverted microstrip cable realised by multilayer technique,

25 figure 1b shows a cross-section of the transmission cable of figure 1a, seen along the line A - A',

figure 2 shows in cross-section a preferred embodiment according to the invention,

30 figure 3 shows in cross-section another preferred embodiment according to the invention,

figure 4 shows in cross-section a third preferred embodiment according to the invention,

figure 5 shows in cross-section a fourth preferred embodiment according to the invention, and

5 figure 6 shows in cross-section a fourth preferred embodiment according to the invention,

Figures 1a and 1b were already dealt with in connection with the description of the prior art.

10 Figures 2 - 6 represent a few preferred embodiments according to the invention. All embodiments illustrated in the drawings consist of elements manufactured by multilayer technique, which elements can in the manufacturing process be combined to form a uniform structure. In the preferred embodiment of the invention illustrated in figure 2, the signal cable 20 of an inverted microstrip cable is attached to a support element 25 according to the invention. The walls  
15 surrounding the transmission cable can be made in a process explained above, in connection with the description of the prior art, for instance of two or more elements 22 and 23, which both are compiled of several green tapes. The sectional plane 26 of the elements, perpendicular to the patterns, is chosen so that the number of work steps in the manufacturing process is minimised. The support  
20 element 25 can likewise be made in several alternative ways. For example, it can be made so that the contact surface of the elements 22 and 23 is placed exactly on the level of the support element surface, which in the drawing is illustrated by a dotted line 26. On both sides of the support element 25, there are made grooves seen in the illustration.

25 Another alternative is to make a groove in the element 23 according to the method described in connection with figure 1a and to manufacture the support element 25 and the signal cable 20 separately with respect to the sectional plane, starting from the sectional plane illustrated by the dotted line 27. The support element 25 and the signal cable 20 are in later manufacturing steps attached, as a uniform structure, on  
30 the bottom of the groove made in the element 23. The ground cable 21 is made either in the way described in connection with figure 1a, or it may be silk-screened in a groove of a suitable size provided in the element 22, if the contact surface of the elements 22 and 23 is the plane illustrated by the dotted line 26. When the elements 22, 23 and the support element 25 are connected, the ground cable 21 is

placed in the cable cavity in parallel with the signal cable 20. From the drawing it is seen that the electromagnetic field emitted from the signal cable 20 towards the ground cable 21, said field being illustrated by the power lines 24, clearly makes a shorter passage in the dielectric material, in the support element 25, than it has to make in the case of figure 1b, inside the element 13 made of a dielectric material. The major part of the transmission cable losses are composed exactly of the losses made in the dielectric material layer. As a consequence, the inverted microstrip cable according to the invention has a smaller attenuation per unit of length than the inverted microstrip cable according to the prior art. However, the impedance level of the transmission cable according to the invention can be adjusted to the desired magnitude, because the impedance of the transmission cable is affected by adjusting the outer dimensions of the support element 25 made of some dielectric material.

In the embodiment illustrated in figure 3, the signal cable 30 of an inverted microstrip cable is attached to a support element 35, which is narrowed in a triangular fashion towards the bottom of the transmission cable cavity. The cable structure according to the drawing is composed of at least two separate elements 32 and 33. The contact surface of the elements, which in the drawing is illustrated by the dotted line 36, is chosen to be the best possible with respect to the manufacturing of the structure. The contact surface 36 of the elements 32 and 33 can be, as is illustrated, the plane 30 of the signal cable attached to the support element 35, but it can also be some other plane. The support element 35 can be produced in connection with the production of the element 33, but it can also be produced separately, in which case its contact surface with the element 33 can be a plane which in the drawing is illustrated by the dotted line 37. Part of the electromagnetic field, illustrated by the power lines 34, emitted from the signal cable 30 towards the ground cable 31, proceeds for a short length inside the support element 35. The part of the electromagnetic field that is left inside the support element is smaller than the part left in the bottom substrate in the prior art arrangement illustrated in figure 1b. In the illustrated preferred embodiment, the attenuation per unit of length is thus lower than the attenuation of an inverted microstrip cable according to the prior art.

In the embodiment illustrated in figure 4, the signal cable 40 of an inverted microstrip cable is attached to a support element 45 that is wider towards the bottom of the groove made in the element 43. The illustrated structure is composed of at least two separate elements 42 and 43. The elements are treated so that inside

them, there is created a cable cavity according to the illustration. The contact surface of the elements 42 and 43, illustrated by the dotted line 46, is chosen to be the best possible with respect to the manufacturing of the product. The contact surface of the elements 42 and 43 can be, as is illustrated, a plane of the signal cable 40 attached to the support element 45, but it may also be another plane that is advantageous for the manufacturing process. In this embodiment, part of the electromagnetic field, illustrated by the power lines 44, emitted from the signal cable 40 towards the ground cable 41, proceeds through the support element 45. However, the part that passes through the support element is remarkably smaller than in the case of the prior art inverted microstrip cable illustrated in figure 1b. Thus the attenuation per unit of length also in this embodiment is lower than in a prior art inverted microstrip cable.

In the embodiment illustrated in figure 5, the signal cable 50 of an inverted microstrip cable is attached to a support element 55 having the shape of a T-beam. The walls encasing the transmission cable are composed of at least two elements 52 and 53, and the sectional plane perpendicular to the patterns of said elements, said sectional plane being illustrated by the dotted line 56, is chosen so that the number of work steps in the manufacturing process is minimised. The support element 55 can be manufactured in several alternative ways. One alternative is to produce the support element 55 and the signal cable 50 separately, starting from the plane at the base of the T-beam, which plane is illustrated by the dotted line 57. The support element 55 and the signal cable 50 are connected, as a uniform structure, to the element 52. The ground cable 51 can be produced for instance in the way illustrated in connection with figure 1b. When the elements 52, 53 and 55 are connected together, the ground cable 51 is located in the cable cavity on the opposite side of the signal cable 50. In figure 5 it is seen that the electromagnetic field emitted from the signal cable 50 towards the ground cable 51, which field in the drawing is illustrated by the power lines 54, passes only a short way in the dielectric material, in the support element 55. As a consequence, the inverted microstrip cable according to the drawing has an extremely low attenuation per length unit, in comparison with the attenuation of a prior art inverted microstrip cable.

In the embodiment illustrated in figure 6, the transmission cable structure is composed of at least two elements 62 and 63. The contact surface of the elements 62 and 63, illustrated by the dotted line 66, is chosen to be the best possible with respect to the manufacturing of the product. It may be located at the illustrated

point, in which case it is level with the surface of the support element 65, which in the drawing is illustrated by the dotted line 66. In this embodiment, the shape of the support element is inwardly curved. The support element 65 constitutes part of the element 63. Also in this embodiment only a small part of the electric field  
5 emitted from the signal cable 60, which in figure 6 is illustrated by the power lines 64, proceeds in the dielectric material of the support element. Likewise, also in this embodiment the attenuation of an inverted microstrip cable according to the invention is low in comparison with a corresponding prior art transmission cable.

In the embodiments described above, the inverted microstrip cable according to the  
10 invention is placed in a cable cavity made of dielectric material layers. The number of the layers constituting the cable cavity wall may vary according to the employed technique and to an optimal number of working steps. The wall strength of the created cable cavity is assumed to be so good in all directions, that the other ground potential levels possibly located in the surroundings are placed far enough  
15 in order to prevent the shape of the electromagnetic field of the transmission cable from being disturbed thereby.

The invention is not restricted to the described embodiments only. For example, the structure of the walls forming the cable cavity can be divided into various levels by innumerable different ways. The employed manufacturing technique  
20 determines which method of dividing the wall parts to be created is optimal with respect to expenses and output. Likewise, the shape of the support element according to the invention can deviate from the preferred embodiments illustrated above. Also the manufacturing method of the employed signal and ground cables  
25 may be other than the suggested silk screen method. Other known cable structures, for example coplanar cable, can also be employed as the cable used in the structure. The inventive idea can be applied in various different ways within the scope of the patent claims.

**Claims**

1. A transmission cable constructed by multilayer technique, located in a cavity comprising a first surface and a second surface essentially parallel with the first surface, said transmission cable consisting of a signal cable (20, 30, 40, 50, 60),  
5 which is essentially parallel to the first cavity surface, and of a ground cable (21, 31, 41, 51, 61), which is placed on said second surface, essentially in parallel with the signal cable, **characterised** in that said cable also comprises a support element (25, 35, 45, 55, 65) which has a surface that is essentially parallel with said first and second surfaces and is located between said first and second surfaces, so that  
10 the signal cable is realised by means of an electroconductive material layer formed on the surface of the support element.
2. A transmission cable according to claim 1, **characterised** in that said support element (25, 35, 45) is rectangular in shape.
3. A transmission cable according to claim 1, **characterised** in that the support  
15 element is a square (25).
4. A transmission cable according to claim 1, **characterised** in that shape of the support element is a T-beam (55).
5. A transmission cable according to claim 1, **characterised** in that the shape of the support element is a surface (65) formed by two curved surfaces.
- 20 6. A transmission cable according to claim 1, **characterised** in that the signal cable is an inverted microstrip cable.
7. A transmission cable according to claim 1, **characterised** in that the signal cable is a coplanar cable.

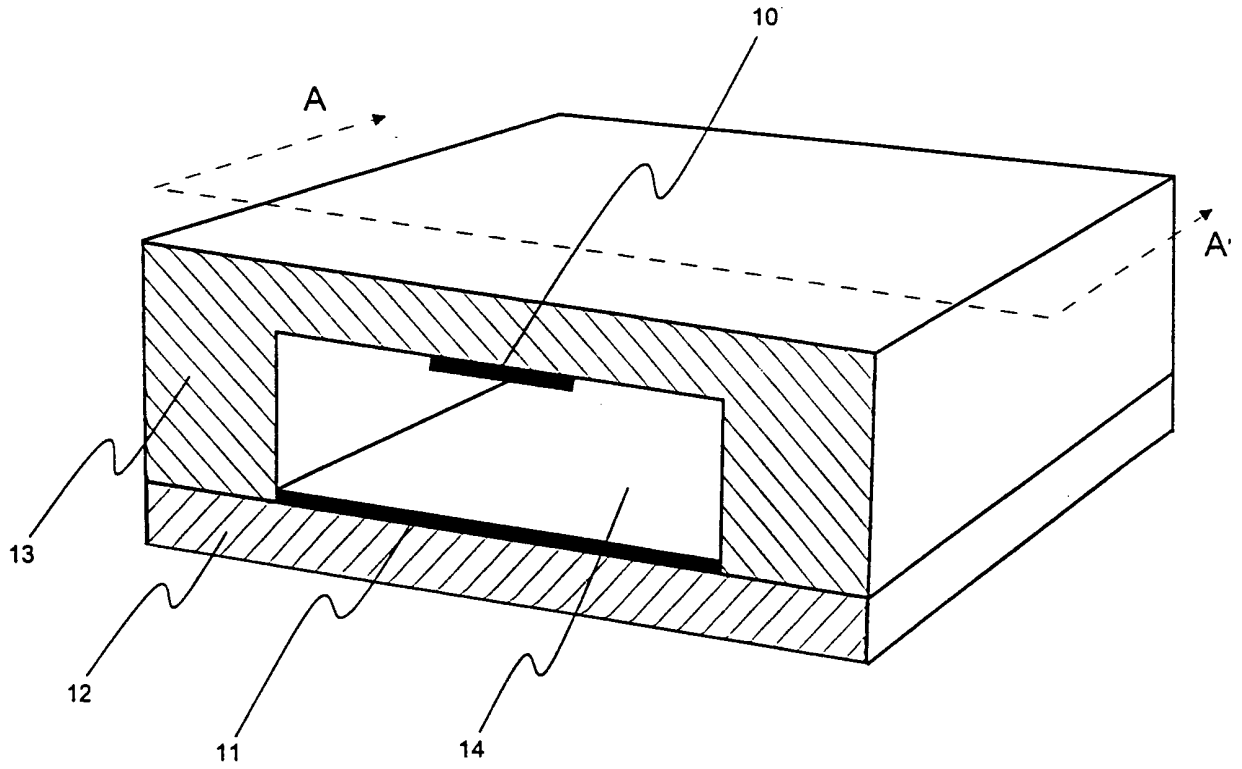

Fig. 1a

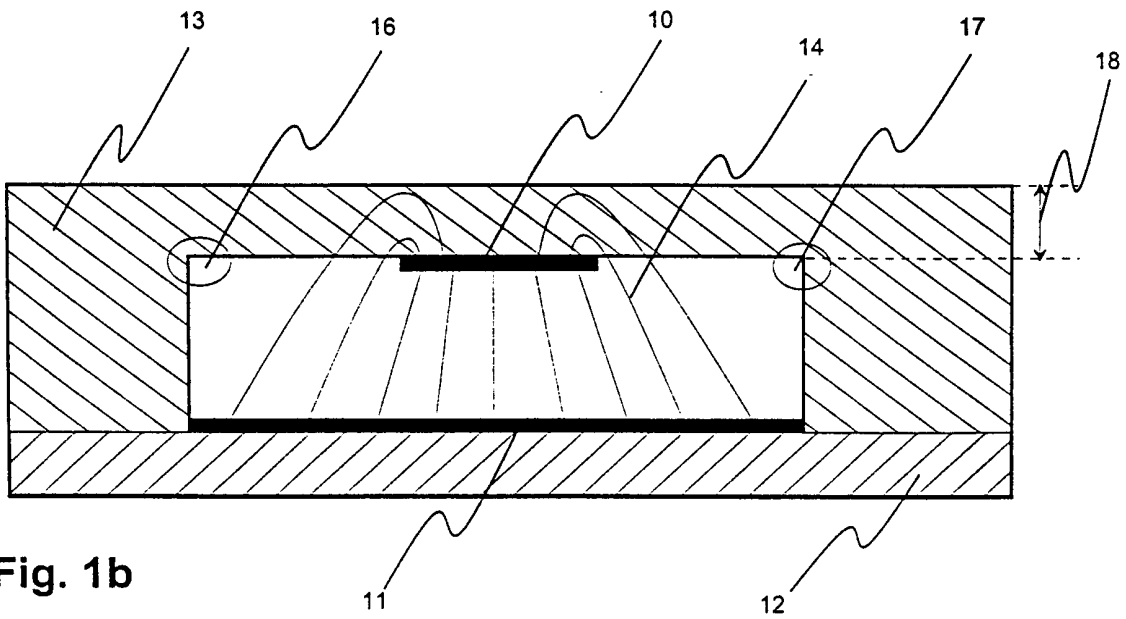

Fig. 1b

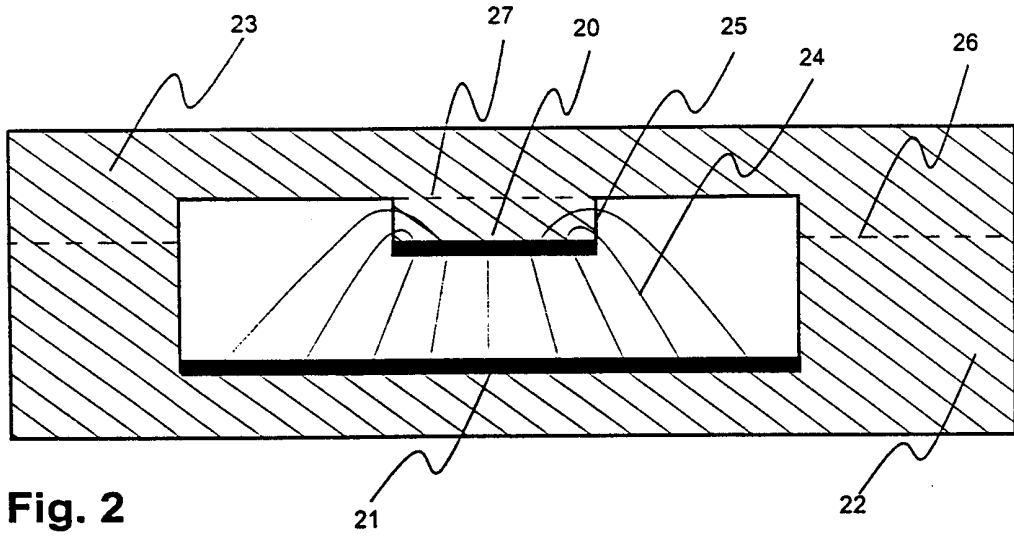

Fig. 2

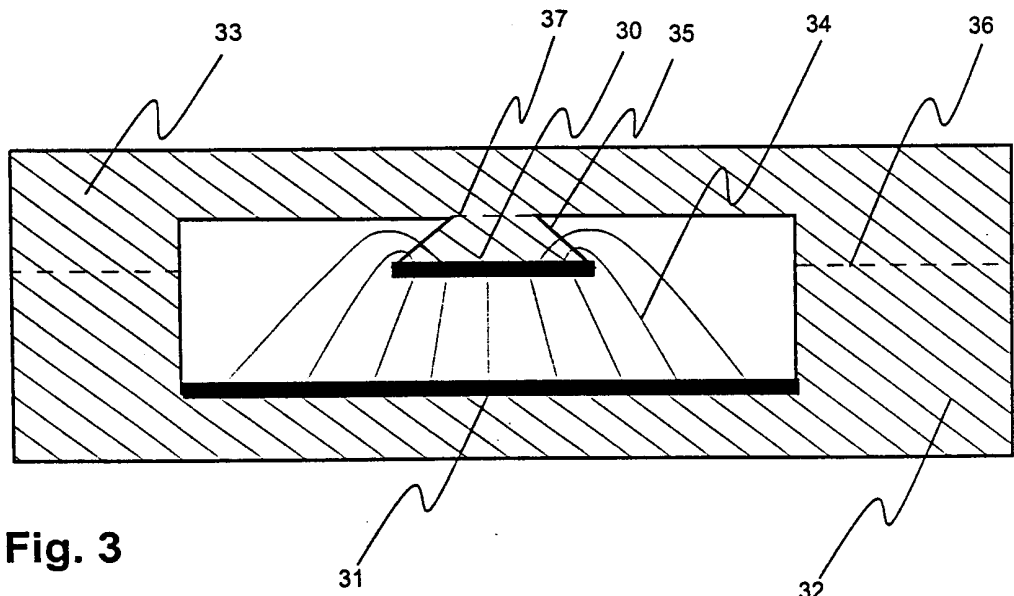

Fig. 3

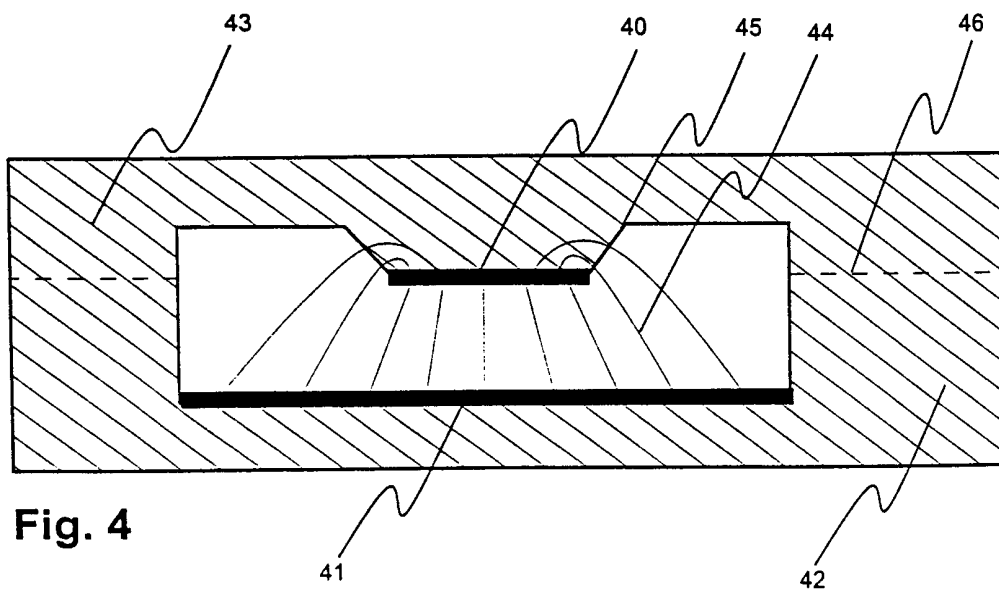
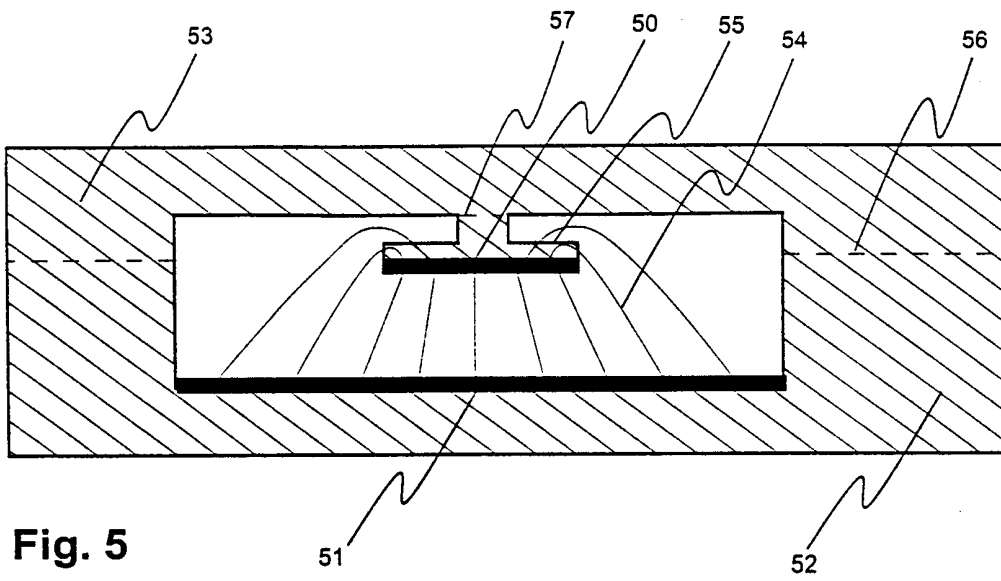
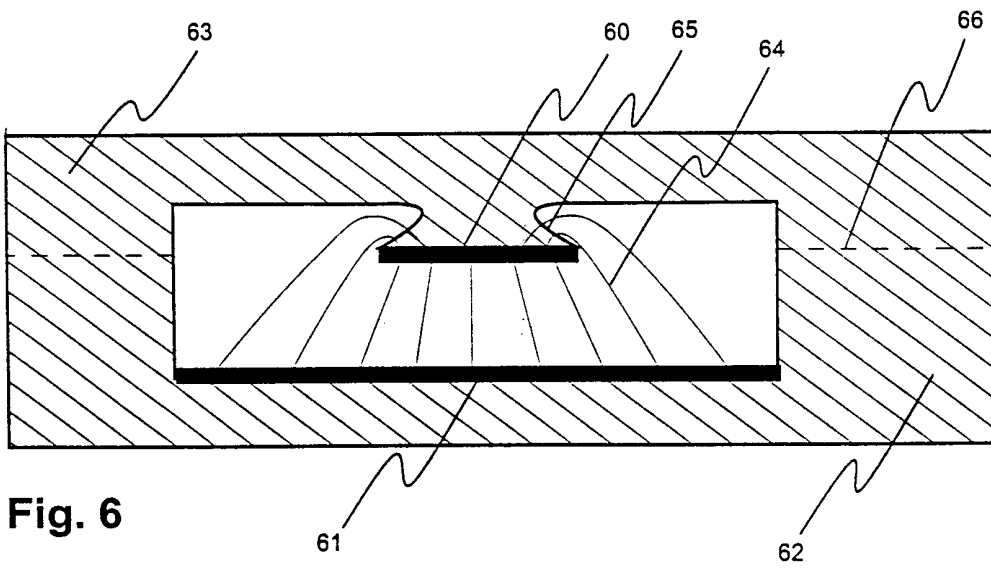

Fig. 4



**Fig. 5**



**Fig. 6**

# INTERNATIONAL SEARCH REPORT

International application No.

**PCT/FI 00/00274**

## A. CLASSIFICATION OF SUBJECT MATTER

**IPC7: H01P 3/08**

According to International Patent Classification (IPC) or to both national classification and IPC

## B. FIELDS SEARCHED

Minimum documentation searched (classification system followed by classification symbols)

**IPC7: H01P**

Documentation searched other than minimum documentation to the extent that such documents are included in the fields searched

**SE,DK,FI,NO classes as above**

Electronic data base consulted during the international search (name of data base and, where practicable, search terms used)

## C. DOCUMENTS CONSIDERED TO BE RELEVANT

Category*	Citation of document, with indication, where appropriate, of the relevant passages	Relevant to claim No.
A	EP 0845831 A2 (MATSUSHITA ELECTRIC INDUSTRIAL CO., LTD.), 3 June 1998 (03.06.98), figures 1A, 1B, abstract --	1-7
A	WO 9302485 A1 (FUJITSU LIMITED), 4 February 1993 (04.02.93), abstract --	1-7
A	JP 4368005 A (SANYO ELECTRIC CO LTD ET AL.), 21 December 1992 (21.12.92), figures 1,4, abstract --	1-7

Further documents are listed in the continuation of Box C.

See patent family annex.

\* Special categories of cited documents:

"A" document defining the general state of the art which is not considered to be of particular relevance

"E" earlier document but published on or after the international filing date

"L" document which may throw doubts on priority claim(s) or which is cited to establish the publication date of another citation or other special reason (as specified)

"O" document referring to an oral disclosure, use, exhibition or other means

"P" document published prior to the international filing date but later than the priority date claimed

"T" later document published after the international filing date or priority date and not in conflict with the application but cited to understand the principle or theory underlying the invention

"X" document of particular relevance: the claimed invention cannot be considered novel or cannot be considered to involve an inventive step when the document is taken alone

"Y" document of particular relevance: the claimed invention cannot be considered to involve an inventive step when the document is combined with one or more other such documents, such combination being obvious to a person skilled in the art

"&" document member of the same patent family

Date of the actual completion of the international search

**24 August 2000**

Date of mailing of the international search report

**28 -08- 2000**

Name and mailing address of the ISA/

Swedish Patent Office

Box 5055, S-102 42 STOCKHOLM

Facsimile No. +46 8 666 02 86

Authorized officer

**Nikolaj Hautaviita/AE**

Telephone No. +46 8 782 25 00

INTERNATIONAL SEARCH REPORT

International application No.

PCT/FI 00/00274

C (Continuation). DOCUMENTS CONSIDERED TO BE RELEVANT		
Category*	Citation of document, with indication, where appropriate, of the relevant passages	Relevant to claim No.
A	JP 09246814 A (IDOUTAI TSUSHIN SENTAN GIJUTSU KENKYUSHO:KK), 19 Sept 1997 (19.09.97), abstract --	1-7
D,A	US 3904997 A (H.E. STINEHELPER, SR.), 9 Sept 1975 (09.09.75), abstract --	1-7
D,A	US 5105055 A (W.C. MOONEY ET AL.), 14 April 1992 (14.04.92), abstract -- -----	1-7

# INTERNATIONAL SEARCH REPORT

Information on patent family members

International application No.

PCT/FI 00/00274

Patent document cited in search report	Publication date	Patent family member(s)	Publication date
EP 0845831 A2	03/06/98	JP 10163711 A US 5990768 A	19/06/98 23/11/99
WO 9302485 A1	04/02/93	US 5493263 A	20/02/96
JP 4368005 A	21/12/92	NONE	
JP 09246814 A	19/09/97	NONE	
US 3904997 A	09/09/75	NONE	
US 5105055 A	14/04/92	NONE	